

Series 16 – Open Circuit Board Controls

- ▶ Solid State Reliability
- ▶ Spade Terminals
- ▶ Time Delays Available
- ▶ U.L. “Motor Control”
- ▶ Optional Dirty Electrode Detection*
- ▶ AC Current Minimizes Electrolysis
- ▶ Compact Size
- ▶ Low-Voltage Sensor
- ▶ LED Monitoring

Series 16 – General Purpose Control

- New Microprocessor Design

Engineered for general purpose single-level or differential applications, these economy priced controls have spade terminals for easy wiring and provide sensitivities up to 1 million ohm/cm.

Series 16D – DPDT Load Contacts

Same features and specifications as Series 16, but these controls also have DPDT load contacts to eliminate the need for slave relays.



Series 16

Specifications

Contact Design	
Series 16	1 N.O. & 1 N.C. (1 form C)*
Series 16D	2 N.O. & 2 N.C. (2 form C)
Contact Rating (120, 240 VAC)	
Series 16	10 amp Resistive 1/3 hp*
Series 16D	5 amp Resistive 1/10 hp
Mode of Operation	
Direct/Inverse, factory set	
Sensitivity	
0-1M ohm, factory set	
Primary Voltage	
120 VAC, 240 VAC, 24 VAC, 208 VAC (+10%/-15%) 50/60 Hz	
208/240: 187 V min. to 255 V max. VAC 50/60 Hz	
Secondary Voltage	
12 VAC, 1.5 mA	
Temperature	
-40°F to +150°F (-40°C to +65°C)	
Approvals	
U.L. 508 File # E44426	
Terminal Style	
Spade connection	
Options	
Time Delays, Retrofit Plate, Time Out. See page E-11 for descriptions.	

How to Order

Use the **Bold** characters from the chart below to construct a product code.

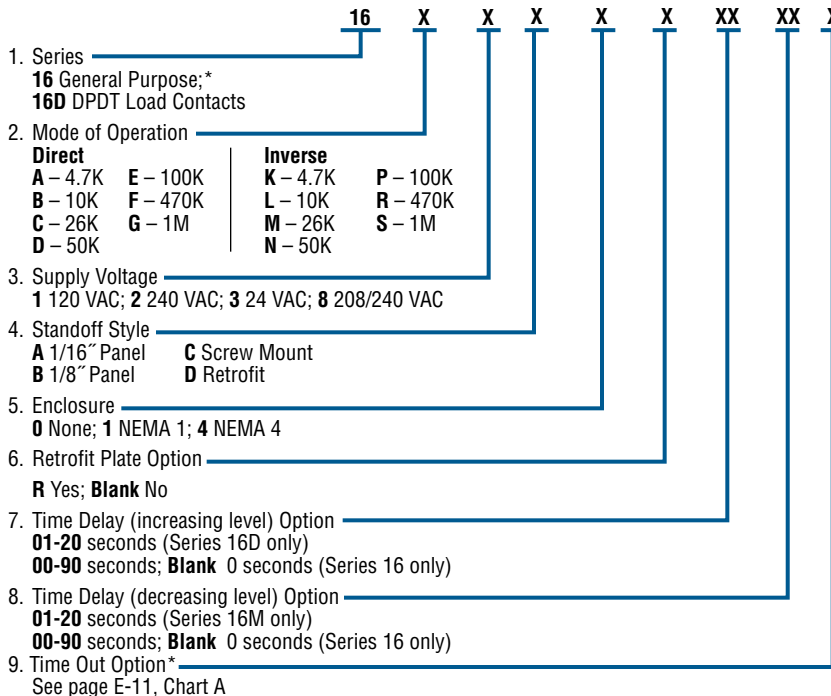

* New Series 16 Microprocessor Design only.

Applications

- Single-Level Service
- Point Level
- Valve Control
- Low-Water Cutoff
- Differential Service
- Alarms
- Pump Control

Dimensions

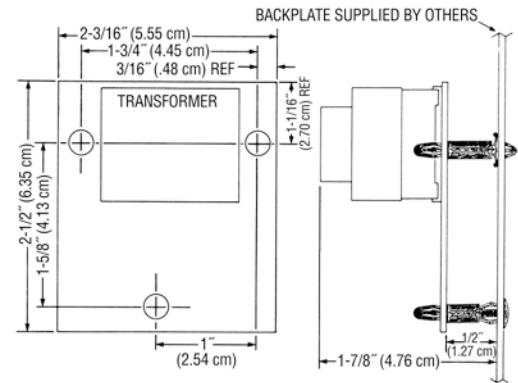

Wiring

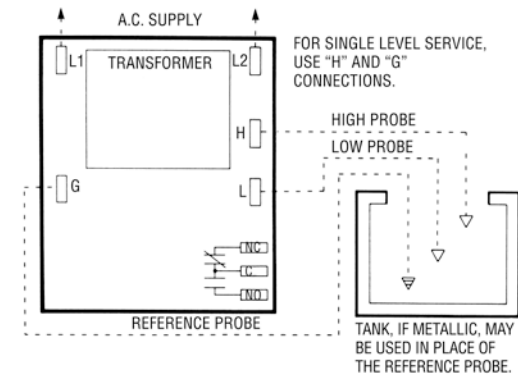

Note: Series 16D similar to Series 16, but with DPDT load contacts.

Series 26 Low Water Cutoff – Standoff Mount

- ▶ Meets CSD1 Requirements
- ▶ Non Powered Contacts
- ▶ Time Delays Available
- ▶ LED Monitoring
- ▶ Test Feature
- ▶ AC Current Minimizes Electrolysis
- ▶ Snap-Thru Standoff Mounting
- ▶ Compact Size
- ▶ Power Outage Feature
- ▶ U.L. “Limit Control”

Series 26 – General Purpose Control

Designed for boiler low-water cutoff protection. A snap-through standoff mounting device is available for Series 26 units. Optional Power Outage feature resets after nuisance outages. Optional reset button is used when device has been deactivated because of low water condition. Reset is functional only if water has returned to normal level. Optional Test Feature available allows LLCO circuit to be tested without draining the water level in the boiler. Built-in 3 second time delay is standard. Up to 90 seconds available for increasing and decreasing levels.

Specifications

Contact Design	1 N.O. & 1 N.C. (1 form C)
Contact Rating	10 amp Resistive 1/3 hp at 120, 240 VAC
Mode of Operation	Direct
Sensitivity	0-100K ohm, factory set
Primary Voltage	120 VAC, 240 VAC ¹ , 24 VAC, 208/240 VAC (+10%/-15%) 50/60 Hz
Secondary Voltage	12 VAC, 1.5 mA
Temperature	-40°F to +150°F (-40°C to +65°C)
Approvals¹	U.L. 353, U.L. 508 File # MP1430
Terminal Style	Spade connection
Options	Time Delays, Power Outage, Retrofit Plate, Test Feature, See page E-11 for descriptions

Notes:

1. 240 VAC and 208/240 VAC are not U.L. recognized

How to Order

Use the **Bold** characters from the chart below to construct a product code.

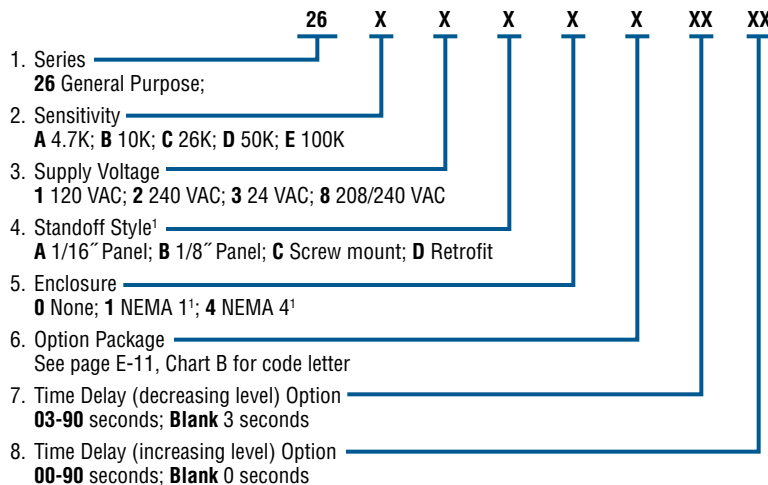

Notes:

1. Standoff Style **D** only.

Socket Details and Option Availability are located on web site.



Applications

- Low-Water Cutoff
- Point Level
- Valve Control
- Single-Level Service
- Alarms
- Pump Control

Dimensions

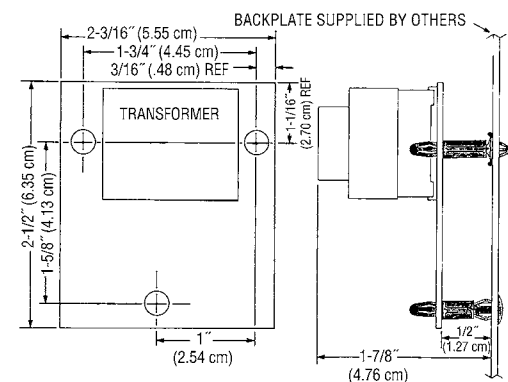

Wiring

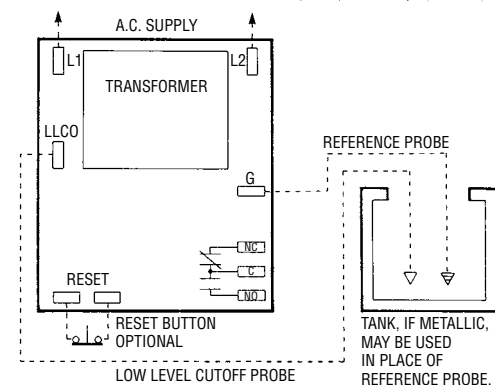

Series DF Dual Function Controls

- ▶ Solid State Reliability
- ▶ Compact Size
- ▶ Meets CSD1 Requirements
- ▶ U.L. "Motor Control"
- ▶ AC Current Minimizes Electrolysis
- ▶ Optional Test Feature
- ▶ Optional Dirty Electrode Detection
- ▶ Spade Terminals for Easy Wiring
- ▶ Manual Reset (optional)
- ▶ Power Outage Feature (optional)
- ▶ U.L. "Limit Control"
- ▶ U.L. "Limit Control"
- ▶ Time Out Option

Dual function Series DF models are designed to control two independent level functions, one single-level control operation and one differential-level operation.

Optional Power Outage feature resets after nuisance outages. Optional Reset Button is used when device has been deactivated due to low water condition. Reset is activated only after water has returned to normal level. This control is ideal in applications on boilers, food service equipment, and chemical delivery systems.

Specifications

Contact Design	1 N.O. & 1 N.C. (1 form C) extra function
Contact Rating (120, 240 VAC)	10 amp Resistive 1/3 hp
Mode of Operation	H/L Direct/Inverse, LLCO – factory set
Sensitivity	0-26K ohm, factory set
Primary Voltage	120 VAC, 240 VAC ¹ , 24 VAC (+10%/-15%) 208/240: 187 V min. to 255 V max. VAC 50/60 Hz
Secondary Voltage	12 VAC
Temperature	-40°F to +150°F (-40°C to +65°C)
Approvals	U.L. 508 File # E44426, U.L. 353 File # MP1430
Terminal Style	Spade connection
Options	Time Delays, Manual Reset, Power Outage, Retrofit Plate, Test Feature, Dirty Electrode Detection; See page E-11 for descriptions

Notes:

- 240 VAC and 208/240 VAC units do not carry U.L. Limit Control recognition.

How to Order

Use the **Bold** characters from the chart below to construct a product code.

	DF	X	X	X	X	X	XX	XX	XX
1. Series	DF	X	X	X	X	X	XX	XX	XX
2. Mode of Operation	Direct	Inverse							
	A – 4.7K	K – 4.7K							
	B – 10K	L – 10K							
	C – 26K	M – 26K							
	D – 50K	N – 50K							
	E – 100K	P – 100K							
3. Supply Voltage	1 – 120 VAC; 2 – 240 VAC;								
	3 – 24 VAC; 8 – 208/240 VAC								
4. Standoff Style*	A – 1/16" Panel	C – Screw Mount							
	B – 1/8" Panel	D – Retrofit							
5. Enclosure	0 – None; 1 – NEMA 1; 4 – NEMA 4								
6. Option Package	See page E-11, Chart B for code letter.								
7. Time Delay (increasing level) H/L function	00-90 seconds; Blank 0 seconds								
8. Time Delay (decreasing level) H/L function	00-90 seconds; Blank 0 seconds								
9. Time Delay (decreasing level) LLCO function only	03-90 seconds; Blank 3 seconds								

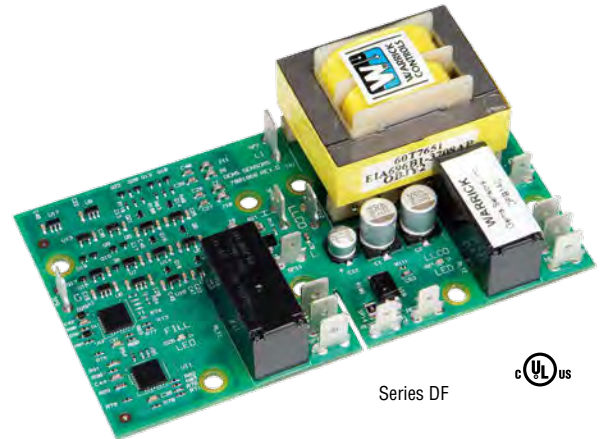

Series DF



Applications

- Dual Function
- Single-Level Service
- Differential Service
- Feedwater Control / Low-Water Cutoff
- High Level / Low Level
- Pump Down / High Level

Dimensions

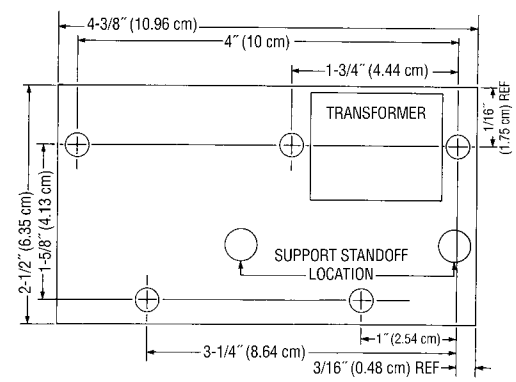

Wiring

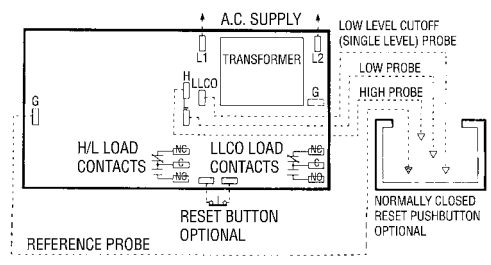

Note: For single level service, use "H" and "G" connections.

Socket Details and Option Availability are located on web site.

WARRICK CONDUCTIVITY SENSORS

Sockets and Standoffs – 16, 26 and DF Series Only



Sockets

Warrick provides four different types of sockets for use with plug-in control modules.

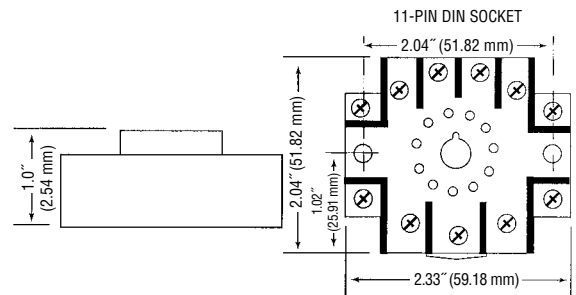
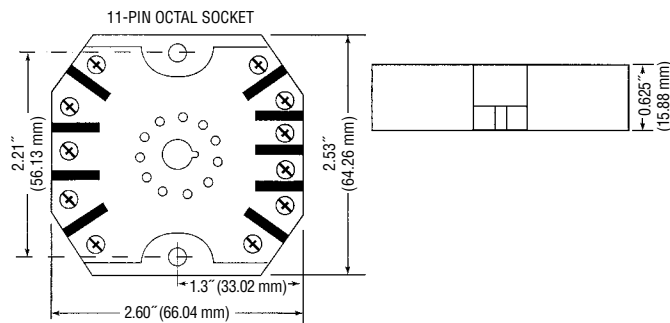
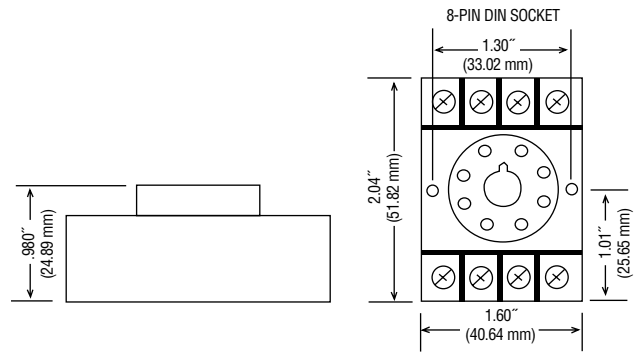
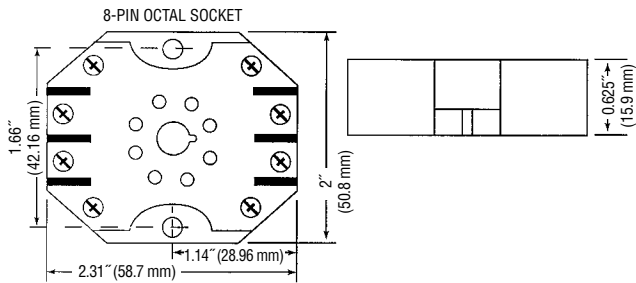

Standoffs

Warrick provides four different types of standoffs designed to connect circuit boards to panels.

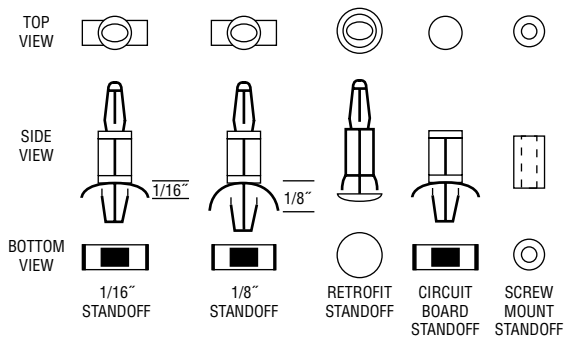

Optional Character Reference – 16, 26 and DF Series Only

Manual Reset

Available on Series 26, 26M and DF controls

(Normally closed pushbutton across reset terminals. Pushbutton ordered separately): Manual reset only applies to the function associated with terminal LLCO. When the liquid rises to the electrode on terminal LLCO, the control will remain de-energized (load contacts in original state) until the pushbutton is depressed. The control will then energize, (LED will be lit) changing the state of the contacts. The control remains energized until the liquid level recedes below electrode on terminal LLCO. The control then de-energizes, (LED will go off) returning load contacts to their original state. Unless otherwise specified, there is a three second time delay on decreasing level. Liquid must be below probe on terminal LLCO for full three seconds before control de-energizes.

Manual Reset with Power Outage Feature

Available on Series 26, 26M, and DF controls

Reset (Normally closed pushbutton across reset terminals. Pushbutton ordered separately) Control will ignore power loss to control. With liquid in contact with electrode on terminal LLCO, a power outage will cause the control to de-energize, but will automatically energize upon return of power. However, loss of liquid will cause control to de-energize and remain so until liquid again rises to electrode and pushbutton is depressed.

Time Delays Associated with Terminals H and L

Available on Series 16, 16M, and DF controls

With time delay on increasing level, the liquid must be in contact with the high electrode for the full duration of the time delay before control will operate. With delay on decreasing level, the liquid must be below the low electrode for the full duration of the time delay before control will operate. In single level service, terminals 3 and 4 must be jumpered together to achieve time delays on both increasing and decreasing levels or just decreasing level.

Time Delays Associated with Terminal LLCO

Available on Series 26, 26M, and DF controls

3 Second time delay on decreasing level is standard. Delay up to 90 seconds, can be specified and would act in the same manner as listed above.

Time Out Option

Available on Series 16, 16M, and DF controls

The latching circuit for the high and low electrode has an optional timer. In some applications the High or Low electrode may become short circuited or disconnected. Such an occurrence may potentially over fill in fill applications, or cause the pump to run dry in pump down applications. The time option is custom programmed up to 3 minutes. When a fault condition occurs, the FILL LED will have a blink sequence of .5 seconds on 2 seconds off. See Chart A for time delay options.

Test Feature

Available on Series 26, 26M, and DF controls

Allows LLCO circuit to be tested. Holding down the reset button for 3 seconds will allow the LLCO circuit to trip which simulates the loss of water, without the need of draining the water level in the boiler. The control will return to normal operation once the reset button is pressed a second time. (Test feature option only available with the manual reset function.)

Chart A – Time Out Option

Optional Character	Time Out (in seconds)					
	30	60	90	120	150	180
K	•					
L		•				
M			•			
N				•		
P					•	
Q						•

Chart B – Optional Character Information

Reset Function	Option Components				Control Series	Optional Character
	Normally Closed Pushbutton*	Power Outage	Retrofit Plate	Test Feature		
•					DF "LLCO"	D
•	•				26, 26M, 26NM	C
•		•			26, 26M, 26NM	E
•			•		16, 16D, 26, DF	R
•	•				DF "LLCO"	S
•		•			DF "LLCO"	K
•			•		DF	W
•				•	26, 26M, 26NM, DF"LLCO"	B
•	•	•			26, 26M, 26NM	F
•		•	•		26	N
•	•	•			DF "LLCO"	G
•	•		•		DF	T
•	•			•	26, 26M, 26NM, DF"LLCO"	Y
•		•	•		DF	L
•		•		•	26, 26M, 26NM, DF"LLCO"	Z
•	•	•	•		26	P
•	•	•	•		DF	J
•	•	•		•	26, 26M, 26NM, DF"LLCO"	A
No options						X

* N.C. pushbutton when purchased in conjunction with open control must be remotely mounted by customer