



Sensaras

PLS1660 Series

Sound Steadfast Solutions

Made in the U.S.A

Invasive Point Level System Solar Powered

Description

The Ultrasonic Point Level System 166 Series is an ideal solution for detecting liquid in storage vessels, tanks and pipes using solar power. With integrated electronics it is designed for almost any liquid level application where supplying power is an issue. The probe is constructed in 316LSS material. The electronic module, solar power system and accessories are mounted in a powder coated die cast aluminum enclosure. No calibration for the system is required. A LED strobe indicator on the enclosure offers a visual status of the system. An audio alarm and reset switch is standard along with the battery status and a Demand Push button self-test feature on the electronic module assures the user the system is functioning correctly. A 0.5 second delay is added from WET to DRY to avoid false trip due to wave action.



Operation

The 166 Series unit consists of two piezoelectric elements mounted in the housing of the sensor. These elements convert mechanical energy in the form of high frequency sound to electrical energy and vice versa. The elements are mounted parallel and opposite each other across the gap in the probe. A high frequency sent from the electronics to the transmitting element, this vibrates the element at 2 to 4 MHz. Air or gases will not carry sound at this high frequency and does not travel across the sensor gap. When the gap is filled with liquid, the sound will travel across the gap to vibrate the receiving element. The vibration generates an electrical signal that is amplified and read by the detector circuit in the electronics as a "wet" signal. The signal is converted to an output.

How to Order

PLS166- _ _ _ _ _

Applications

Industries Served

Solar Power 12VDC - 0	-						
Output: LED / Audio -	1					High Level / Overflow Alarm	Upstream Oil & Gas
Mounting Integral -	--	--	1	0		Low Level / Pump Protection	Midstream Oil & Gas
Remote -	--	--	2			Condensate Pots	Water & Waste- Water
Cable (remote) in feet -	--	--	--	01		Sump Water / Oil Detection	Chemical & Petrochemical
Actuation point inches (01"std) -	--	--	--	--	01	Lubricant Circulation Equipment	Pulp & Paper
Process connection 3/4"NPT -	--	--	--	--	3	Fill Machine Level Control	Food & Beverage
Flange ANSI 150# -	--	--	--	--	A	Pump Leak Detection	Military, Subsea / Surface
Flange ANSI 300# -	--	--	--	--	B		Maritime Shipping
Flange Sanitary -	--	--	--	--	C		Inland Barges, ERC Cargo
Flange size 1" -	--	--	--	--	1		
1.5" -	--	--	--	--	0		
2" -	--	--	--	--	2		
	--						

Order from: **C A Briggs Company**

622 Mary Street; Suite 101; Warminster, PA 18974

Phone: 267-673-8117 - Fax: 267-673-8118

Sales@cabriggs.com - www.cabriggs.com

Specifications

Repeatability: 2mm or better.

Delay (on): 0.5 seconds Standard.
Options available.

Probe material: 316SS Standard.
Optional material available.

Actuation point: 1.0" Standard.
Up to 99" available.

Sensor Temperature: -22 to 140°F

Sensor Pressure: 1000 PSIG 316SS.

Liquid viscosity : From 1 to 75,000 cps

Process connection: 3/4" NPT Standard.
Flanges available.

Electronic mounting : Integral or Remote

Input: Solar Powered (12VDC)

Output: Visual and Audio

Enclosure: Aluminum Epoxy coated

Push Button Demand Self-Test

Audio Reset switch

Battery health LED Indicator

Dimensions

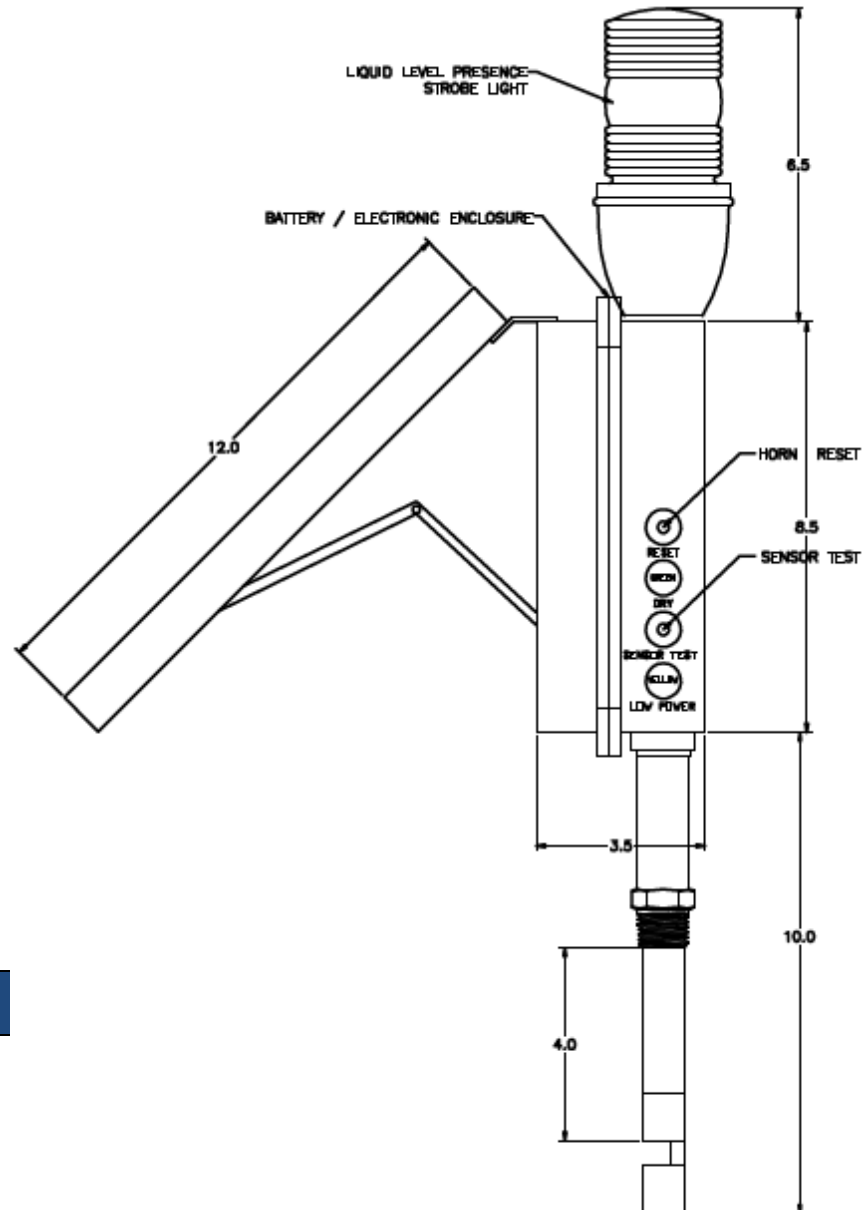

Warranty

Sensaras' level sensors are warranted against inherent defects for a period of 24 months from the date of shipment.

Performance Guarantee

Should the unit not perform as we claim within 45 days of delivery and was properly installed consistent with our stated requirements and specifications Sensaras will gladly accept a return of the unit for a full credit.

Designed to meet intrinsic safety for Hazardous locations. UL Approval pending

Disclaimer: Due to technical progress all Data Sheets are subject to change without notice. Sensaras believes all information in this Data Sheet is correct but is not responsible for any inaccuracies. Sensaras is not liable for any damages. It is the customer's responsibility to install, operate and maintain products properly.

Order from: **C A Briggs Company**

622 Mary Street; Suite 101; Warminster, PA 18974

Phone: 267-673-8117 - Fax: 267-673-8118

Sales@cabriggs.com - www.cabriggs.com