



Sensaras

PLS1640 Series

Sound Steadfast Solutions

Made in the U.S.A

Invasive Point Level System



Description

The Ultrasonic Point Level System 1640 Series is an ideal solution for detecting low temperature liquid from -50° to 120°C in storage vessels, tanks and pipes. With integrated electronics it is a designed for almost any liquid level application. The probe is constructed in 316LSS material. The electronic module is captured in a plastic cassette and is mounted in a NEMA 4/ 7 explosion proof housing. An LED indicator on the electronic module offers a visual status of the system. Field selectable Fail safe allows for the relays to be energized on power up or in normal condition to de-energized when liquid is present. A Demand Push button self-test feature on the electronic module assures the user the system is functioning.

Operation

The 1640 Series unit consists of two piezoelectric elements mounted in the housing of the sensor. These elements convert mechanical energy in the form of high frequency sound to electrical energy and vice versa. The elements are mounted parallel and opposite each other across the 5/16" gap in the probe. A high frequency is sent from the electronics to the transmitting element, this vibrates the element at 2 to 4 MHz. Neither Air nor gases will carry sound at this high frequency and will not travel across the sensor gap. When the gap is filled with liquid, the sound will travel across the gap to vibrate the receiving element. The vibration generates an electrical signal that is amplified and read by the detector circuit in the electronics as a "wet" signal. The signal is converted to a relay output or a shift in milliamp output.

How to Order	PLS164- _ _ _ _ _	Applications	Industries Served
Input 24VDC - 0		High Level / Overflow Alarm	Upstream Oil & Gas
90 to 240VAC - 1			
Output: 10A DPDT - -- 0		Low Level / Pump Protection	Midstream Oil & Gas
9-30VDC - 2			
Loop Power (4-20mA) - -- 1		Condensate Pots	Pulp & Paper
Mounting Integral. - -- 1 0			
Remote - -- 2		Pump Leak Detection	Chemical & Petrochemical
Cable (remote) in feet - -- -- 01			
Actuation point inches (01"std) - -- -- -- 01		Fill Machine Level Control	Food & Beverage
Process connection (1/2"NPT) - -- -- -- -- 2			
(3/4" NPT) - -- -- -- -- 3			
Flange ANSI 150# - -- -- -- -- A			
Flange ANSI 300# - -- -- -- -- B			
Flange Sanitary - -- -- -- -- C			
Flange size 1" - -- -- -- -- 1			
1.5" - -- -- -- -- 0			
2" - -- -- -- -- 2			

Specifications

Dimensions

Repeatability: 2mm or better.

**Delay (on): 0.5 seconds Standard.
Options available.**

**Probe material: 316SS Standard.
Optional material available.**

**Actuation point: 1.0" Standard.
Up to 99" available.**

Sensor Temperature: -50 to 150°C

Sensor Pressure: 1000 PSIG 316SS.

Liquid viscosity : From 1 to 50,000 cps

**Process connection: 3/4" NPT Standard.
Flanges available.**

Electronic mounting : Integral or Remote

**Input options: 24VDC, 90 to 240VAC,
9-30VDC**

**Output Options: 10A DPDT
Loop Power 4-16mA**

Enclosure: Nema 4 / 7

Push Button Demand Self-Test

Field Select Fail-Safe Option

LED Output Indicator

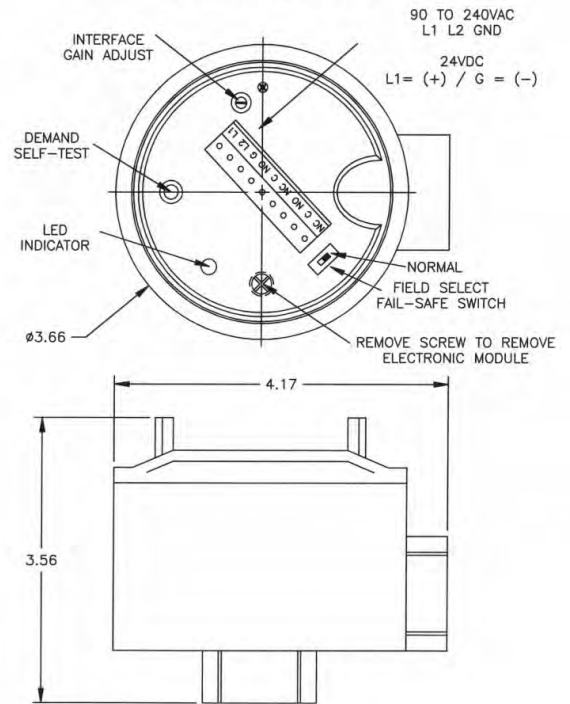
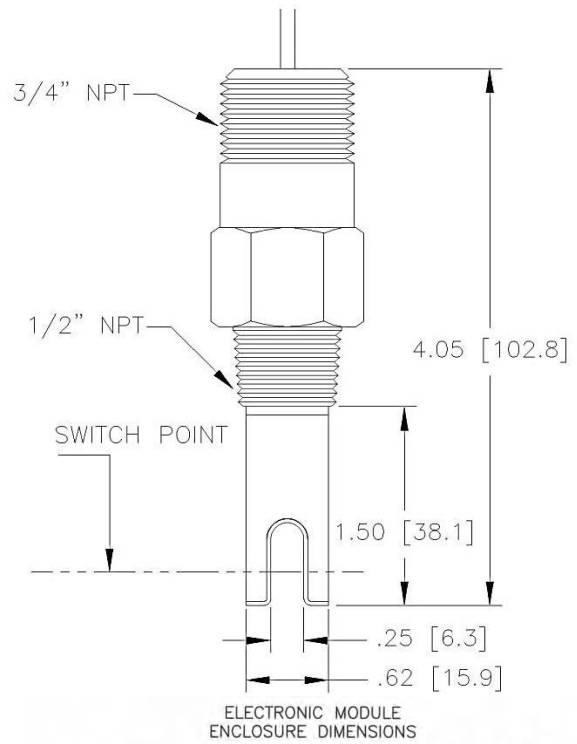

Warranty

Sensaras' level sensors are warranted against inherent defects for a period of two years from the date of shipment.

Performance Guarantee

Should the unit not perform as we claim within 45 days of delivery and was properly installed consistent with our stated requirements and specifications Sensaras will gladly accept a return of the unit for a full credit.

Designed to meet intrinsic safety for Hazardous locations. UL Approval pending

Disclaimer: Due to technical progress all Data Sheets are subject to change without notice. Sensaras believes all information in this Data Sheet is correct but is not responsible for any inaccuracies. Sensaras is not liable for any damages. It is the customer's responsibility to install, operate and maintain products properly.