



Sensaras

PLS1630 Series

Sound Steadfast Solutions

Made in the U.S.A

Invasive Point Level System

Description

The Ultrasonic Point Level System 1630 Series is an ideal solution for detecting when sludge in clarifiers or tanks is at a desired level and automatically operates pumps or valves to maintain the sludge at the proper level. Maintaining the proper level of sludge contributes to improved plant efficiency and effluent quality by providing for automatic sludge withdrawal for a controllable time period so that sludge of a desired density is delivered to the digester or thickener and preventing the carryover of solids into the effluent system. The probe is constructed in 316LSS material. The electronic module is captured in a plastic cassette and is mounted in a NEMA 4/ 7 explosion proof housing. An LED indicator on the electronic module offers a visual status of the system. Field selectable Fail safe allows for the relays to be energized on power up or in normal condition to de-energized when liquid is present.



A Demand Push button self-test feature on the electronic module assures the user the system is functioning correctly. The sensor's construction provides the flexibility of using one sensor for a single point or a number of sensors to detect the sludge at various levels.

Operation

The 1630 Series unit consists of two piezoelectric elements mounted in the housing of the sensor. These elements convert mechanical energy in the form of high frequency sound to electrical energy and vice versa. The elements are mounted parallel and opposite each other across the 6" gap of the sensor. The control unit senses the change in the percent solid by means of the attenuation of the sonic energy being transmitted through the liquid. Thin or clear liquids exhibits less attenuation than viscous liquids, emulsions or liquids with entrained solids. Since present solids is the predominant variable, the attenuation becomes greater as the settled sludge builds up to the level of the sensor. This attenuation is detected by the control system, the amplifier gain adjustment in the control unit is set so that the relays energize only when the level of sludge is within the path of the ultrasonic signal of the sensor.

How to Order PLS163- - - - -

Input 24VDC	0					
90 to 240VAC	1					
9-30VDC	2					
Output: 10 ADPDT	-- 0					
Loop Power (4-20mA)	-- 1					
Mounting Remote Nema 4/7	-- -- 1					
Remote Nema 4	-- -- 2					
Cable (remote) in feet (1'std)	-- -- -- 01					
Process connection (3/4"std)	-- -- -- -- 3					



Order from: **C A Briggs Company**

622 Mary Street; Suite 101; Warminster, PA 18974

Phone: 267-673-8117 - Fax: 267-673-8118

Sales@cabriggs.com - www.cabriggs.com

Specifications

Repeatability: 5mm or better.

Delay (on): 0.5 seconds Standard.

Electronic mounting : Integral or Remote

Enclosure: Nema 4 / 7, Nema 4

Field Select Fail-Safe Option

Input options: 24VDC, 90 to 240VAC, 9-30VDC

LED Output Indicator

Probe material: 316SS Standard.

Sensor Temperature: -20 to 240°C

Sensor Pressure: 1000 PSIG 316SS.

Liquid viscosity : From 1 to 150,000 cps

Process connection: 3/4" NPT Standard.

Output Opt: 10A DPDT Loop Power 4-16mA

Push Button Demand Self-Test

Dimensions

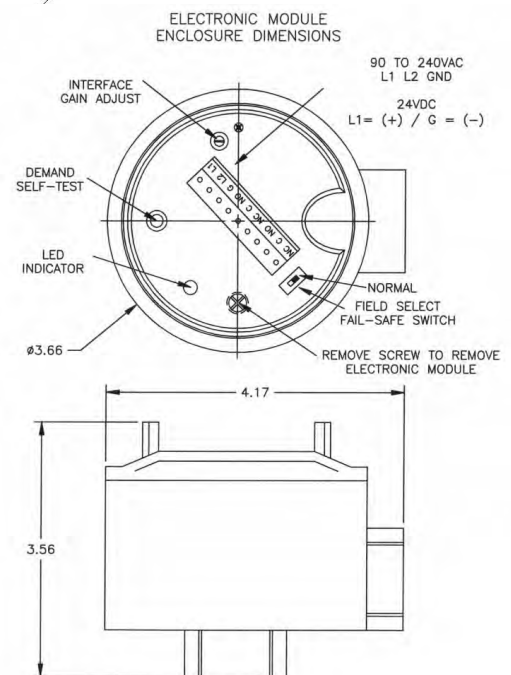
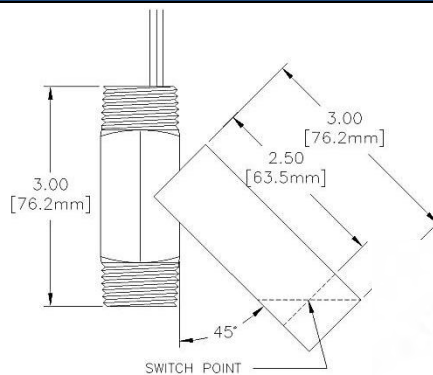
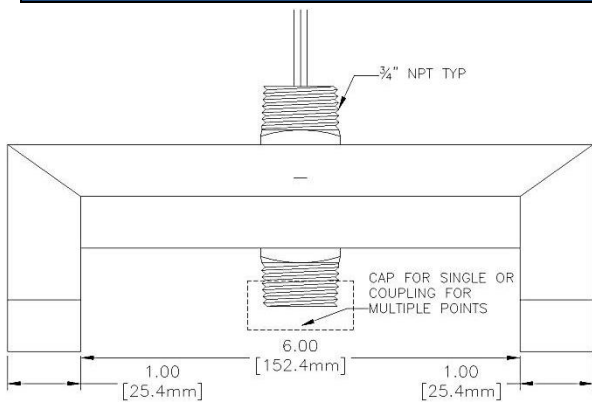

Warranty

Sensaras' level sensors are warranted against Inherent defects for a period of two years from the date of shipment.

Performance Guarantee

Should the unit not perform as we claim within 45 days of delivery and was properly installed consistent with our stated requirements and specifications Sensaras will gladly accept a return of the unit for a full credit.

Designed to meet intrinsic safety for Hazardous locations. UL Approval pending.

Disclaimer: Due to technical progress all Data Sheets are subject to change without notice. Sensaras believes all information in this Data Sheet is correct but is not responsible for any inaccuracies. Sensaras is not liable for any damages. It is the customer's responsibility to install, operate and maintain products properly.

Order from: **C A Briggs Company**

622 Mary Street; Suite 101; Warminster, PA 18974

Phone: 267-673-8117 - Fax: 267-673-8118

Sales@cabriggs.com - www.cabriggs.com