



Sensaras

PLS163 Series

Sound Steadfast Solutions

Made in the U.S.A.

Invasive Point Level System

Sludge Blanket Sensor



Description

Ultrasonic Point Level System 163 Series is an ideal solution for detecting when sludge in clarifiers or tanks is at a desired level. Maintaining the proper level of sludge contributes to improved plant efficiency and effluent quality by providing for automatic sludge withdrawal for a controllable time period so that sludge of a desired density is delivered to the digester or thickener and preventing the carryover of solids into the effluent system. Constructed in 316LSS material. The electronic module is captured in a plastic cassette and is mounted in a NEMA 4/ 7 explosion proof housing. An LED indicator on the electronic module offers a visual status of the system. Field selectable Relay Fail Safe option is standard. A Demand Push button self-test feature on the electronic module assures the user the system is functioning correctly. The sensor's construction provides the flexibility of using one sensor for a single point or a number of sensors to detect the sludge at various levels.

Operation

The 163 Series unit consists of two piezoelectric elements mounted in the housing of the sensor. These elements convert mechanical energy in the form of high frequency sound to electrical energy and vice versa. The elements are mounted parallel and opposite each other across the 6" gap of the sensor. The control unit senses the change in the percent solid by means of the attenuation of the sonic energy being transmitted through the liquid. Thin or clear liquids exhibits less attenuation than viscous liquids, emulsions or liquids with entrained solids. Since present solids is the predominant variable, the attenuation becomes greater as the settled sludge builds up to the level of the sensor. This attenuation is detected by the control system, the amplifier gain adjustment in the control unit is set so that the relays energize only when the level of sludge is within the path of the ultrasonic signal of the sensor.



How to Order	PLS163-	-	-	-	-	-	-	-	-
Input:	24VDC	-	0						
	90 to 240VAC	-	1						
	9-30VDC	-	2						
Output:	10 ADPDT	--	0						
	Loop Power (4-20mA)	--	1						
Mounting:	Integral	--	--	1					
	Remote	--	--	2					
Cable (remote):	in feet	--	--	--	01				
Actuation point inches (03"std)		--	--	--	--	03			
	Gap (6" std)	--	--	--	--	6			
Process connection	3/4"NPT	--	--	--	--	--	03		
	Sensor Material	--	--	--	--	--	--	S	



Sensor material 316LSS is standard, other materials available
 Other remote mounted enclosures available
 CONSULT C A BRIGGS CO. FOR CUSTOMIZATION

Order from: **C A Briggs Company**

622 Mary Street; Suite 101; Warminster, PA 18974

Phone: 267-673-8117 - Fax: 267-673-8118

Sales@cabriggs.com - www.cabriggs.com

Specifications / Features

Dimensions

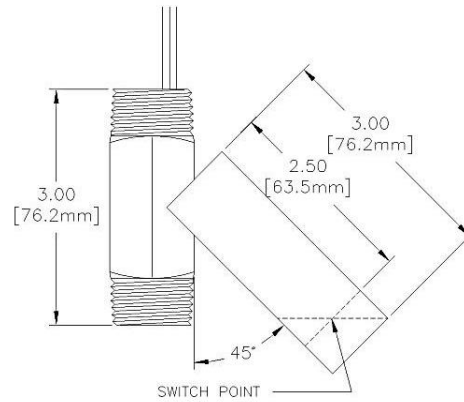
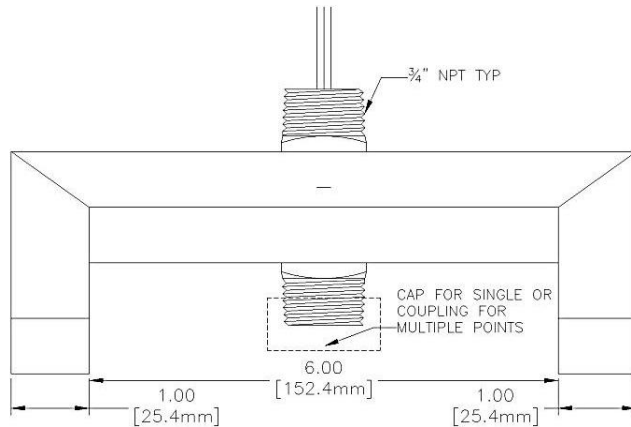

- Repeatability: 2mm or better.**
- Delay (on): 0.5 seconds Standard.**
- Probe material: 316SS Standard.**
- Actuation point: 3.0" Standard.**
- cable Up to 50" available.**
- Sensor Temperature: -20° to 150°C**
- Sensor Pressure: 1000 PSIG 316LSS.**
- Liquid viscosity : From 1 to 75,000 cps**
- Process connection: 3/4" NPT Standard**
- Input options: 24VDC, 90 to 240VAC,**
- Output Options: 10A DPDT**
- Loop Power 4-16mA**
- Push Button Demand Self-Test**
- Field Select Fail-Safe Option**
- Electronic mounting : Integral or Remote**
- Enclosure: Nema 4 / 7**

ELECTRONIC MODULE ENCLOSURE DIMENSIONS

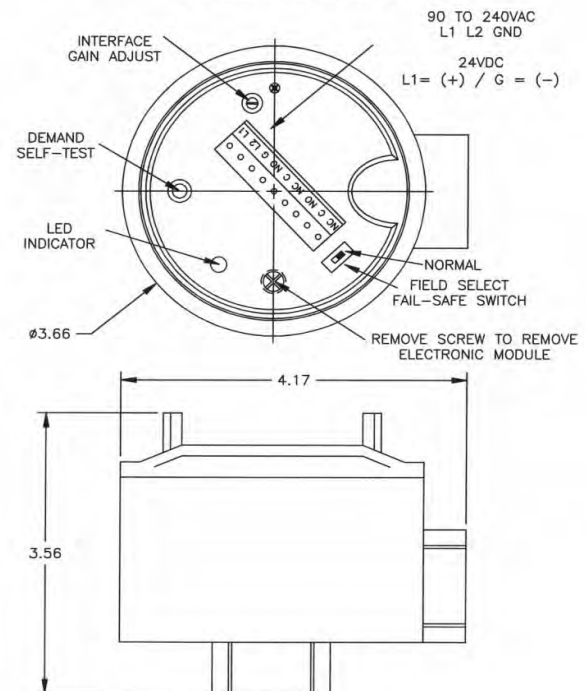

Warranty

Sensaras' level sensors are warranted against inherent defects for a period of two years from the date of shipment.

Performance Guarantee

Should the unit not perform as we claim within 45 days of delivery and was properly installed consistent with our stated requirements and specifications Sensaras will gladly accept a return of the unit for a full credit.

CSA Approval (pending) Explosion Proof
Class I Group CD
Class II Group EFG
Class III Type 4. EP. IP 65.

Disclaimer: Due to technical progress all Data Sheets are subject to change without notice. Sensaras believes all information in this Data Sheet is correct but is not responsible for any inaccuracies. Sensaras is not liable for any damages. It is the customer's responsibility to install, operate and maintain products properly.

Order from: **CA Briggs Company**

622 Mary Street; Suite 101; Warminster, PA 18974

Phone: 267-673-8117 - Fax: 267-673-8118

Sales@cabriggs.com - www.cabriggs.com