

SNOOPER MODEL PD865 MODBUS[®] SERIAL INPUT Instruction Manual



Snooper

- Modbus[®] RTU Master, Slave, or Snooper Mode
- 6-Digit Display, 0.56" (14 mm) High, Red LEDs, Sunlight Readable
- Linear, Square Root, or Programmable Exponent
- 16-Point Linearization
- Maximum/Minimum Display
- Type 4X, NEMA 4X, IP65 Front
- Universal Power Supply 85-265 VAC
- 12-36 VDC/12-24 VAC Power Option
- 2 or 4 Relays + 4-20 mA Output Options
- 24 VDC Transmitter Power Supply Option
- RS-485 Serial Communications
- Proxy Polling for up to 8 Process Variables

Order from:

C A Briggs Company

622 Mary Street; Suite 101
Warminster, PA 18974

Phone: 267-673-8117 - Fax: 267-673-8118

Sales@cabriggs.com - www.cabriggs.com

PRECISION DIGITAL CORPORATION

89 October Hill Road • Holliston, MA 01746 USA

Tel (800) 343-1001 • Fax (508) 655-8990

**PRECISION
DIGITAL** 

www.predig.com

Disclaimer

The information contained in this document is subject to change without notice. Precision Digital makes no representations or warranties with respect to the contents hereof; and specifically disclaim any implied warranties of merchantability or fitness for a particular purpose.



CAUTION: Read complete instructions prior to installation and operation of the meter.



WARNING: Risk of electric shock or personal injury.

**Warning**

This product is not recommended for life support applications or applications where malfunctioning could result in personal injury or property loss. Anyone using this product for such applications does so at his/her own risk. Precision Digital Corporation shall not be held liable for damages resulting from such improper use.

Limited Warranty

Precision Digital Corporation warrants this product against defects in material or workmanship for the specified period under "Specifications" from the date of shipment from the factory. Precision Digital's liability under this limited warranty shall not exceed the purchase value, repair, or replacement of the defective unit.

Registered Trademarks

All trademarks mentioned in this document are the property of their respective owners.

©2010-2012 Precision Digital Corporation. All rights reserved.

www.predig.com

Table of Contents

INTRODUCTION	6
ORDERING INFORMATION	6
SPECIFICATIONS	7
General	7
Operating Modes	8
Programmable Features for Master Mode	9
Serial Communications	9
Display Functions	10
Relays	11
Isolated 4-20 mA Transmitter Output	12
COMPLIANCE INFORMATION	13
Safety	13
SAFETY INFORMATION	13
INSTALLATION	14
Unpacking	14
Panel Mounting	14
MOUNTING DIMENSIONS	15
Connections	16
Connector Labeling	16
Power Connections	17
Serial Connections	18
Relay Connections	19
Switching Inductive Loads	19
4-20 mA Output Connections	21
SETUP AND PROGRAMMING	22
Front Panel Buttons and Status LED Indicators	23
Display Functions and Messages	24
Main Menu	29
Setting Numeric Values	29
Meter Setup	30
Operating Modes (מדידת)	30
Master Mode (מדידת)	31
Proxy Polling Mode	32
Slave Mode (שליטה)	34
Snooper Mode (שנופי)	35
Serial Communications (שדר, קול)	36
Program Menu (פרוגרם)	36
Setting the Display Decimal Point (ד, 15P.dP)	37

PD865 Snooper Modbus Serial Input Meter	Instruction Manual
Setting the Float Decimal Point (<i>FLoat.dP</i>)	37
Scaling the Display Value (<i>ScALe</i>)	38
Setting the Relay Operation (<i>rELAY</i>)	39
Relay and Alarm Operation	42
Scaling the 4-20 mA Analog Output (<i>ROut</i>)	49
Setting Up the Password (<i>PR55</i>)	50
Locking the Meter	50
Unlocking the Meter	51
Advanced Features Menu	52
Advanced Features Menu & Display Messages	53
Display Math Function (<i>FuNC</i>)	54
Noise Filter (<i>FILtEr</i>)	55
Noise Filter Bypass (<i>bYPASS</i>)	55
Low-Flow Cutoff (<i>LutOFF</i>)	55
Analog Output Programming (<i>ROutPr</i>)	56
4-20 mA Output Calibration	57
Display Intensity (<i>d-INTY</i>)	58
Information (<i>INFA</i>)	58
OPERATION	59
Master and Slave Connections	59
Maximum/Minimum Readings	62
TROUBLESHOOTING	63
Determining Software Version	63
Reset Meter to Factory Defaults	63
Factory Defaults & User Settings	64
Troubleshooting Tips	68
SLAVE MODE REGISTER TABLE	69
Register Table Notes	79
Register Bit Assignment Tables	81

Table of Figures

Figure 1: Panel Cutout and Mounting.....	14
Figure 2: Meter Dimensions – Side View.....	15
Figure 3: Case Dimensions – Top View.....	15
Figure 4: Connector Label: 4 Relays, 4-20 mA Out & 24 V Supply	16
Figure 5: Power Connections.....	17
Figure 6: RS-485 Connection	18
Figure 7: Standard and Optional Relay Connectors.....	19
Figure 8: AC and DC Loads Protection	19
Figure 9: Low Voltage DC Loads Protection.....	20
Figure 10: 4-20 mA Output Powered by Meter.....	21
Figure 11: 4-20 mA Output Powered Externally.....	21
Figure 12: PD865 Slave & Snooper Connected to a Master.....	59
Figure 13: PD865 Master Connected to a Smart Sensor & Chart Recorder.....	59
Figure 14: PD865 Master Connected to a PD765 Meter.....	60
Figure 15: PD865 Master & Snoopers Connected to Multivariable Level Transmitters	60
Figure 16: PD865 Master & Snoopers Connected to Level and Temperature Sensors.....	61

INTRODUCTION

The PD865 Snooper Modbus Serial Input Meter can be programmed as a Modbus RTU Master, Slave, or Snooper. As a Master, the PD865 reads a slave device, scales the data from it, displays the result, and operates the internal relays and 4-20 mA output. The PD865 Master mode is capable of polling up to 8 process variables (Proxy polling feature); it displays PV1 and allows other PD865s in Snooper mode to read any of the variables being polled by the Master. As a Slave, it is controlled by a master device. The data sent to it by the master is scaled, displayed, and used to operate the relays and 4-20 mA output. As a Snooper the PD865 listens to the Modbus traffic and picks up a specific register or registers being polled by a Master device from a specific slave device and processes the data being read.

The PD865 Snooper is housed in a shallow-depth 1/8 DIN panel meter enclosure that features a NEMA 4X front panel. Data is displayed on an adjustable intensity, six-digit seven-segment LED display. The Snooper can be powered from 85-265 VAC or 12-36 VDC. It comes standard with 2 relays and is available with 2 additional relays and 4-20 mA output as options.

ORDERING INFORMATION

85-265 VAC* Model	12-36 VDC* Model	Installed
PD865-6R2-06		2 relays
PD865-6R5-16		2 relays, 4-20 mA output/24 V transmitter supply
PD865-6R7-16		4 relays, 4-20 mA output/24 V transmitter supply
	PD865-7R5-06	2 relays, 4-20 mA output
	PD865-7R7-06	4 relays, 4-20 mA output

*All models may be powered from AC or DC. See Specifications for details.

Accessories

Model	Description
PDA7485-I	RS-232 to RS-422/485 Isolated Converter
PDA7485-N	RS-232 to RS-422/485 Non-Isolated Converter
PDA8485-I	USB to RS-422/485 Isolated Converter
PDA8485-N	USB to RS-422/485 Non-Isolated Converter
PDX6901	Suppressor (snubber): 0.01 μ F/470 Ω , 250 VAC
Enclosures	NEMA 4 & explosion-proof enclosures** Plastic, steel, stainless steel & cast aluminum
**Enclosures available for 1-10 meters. Visit our website for details.	

SPECIFICATIONS

Except where noted all specifications apply to operation at +25°C.

General

Input/Output	Modbus RTU over RS-485		
DISPLAY	Six digits, 0.56" (14 mm) high, red LED. Displays from -199999 to 999999, automatic leading zero blanking.		
DISPLAY UPDATE RATE	Master: 10/second to once every 25.5 seconds Slave/Snooper: Dependent on master device (e.g. PLC)		
OVERRANGE	Values greater than the highest Input value programmed cause the display to flash 999999		
UNDERRANGE	Values less than the Input 1 value cause the display to flash - 199999		
PROGRAMMING METHODS	Four front panel buttons, or via Modbus registers.		
RECALIBRATION	Only required for the 4-20 mA output. Calibrated at the factory. Recalibration is recommended at least every 12 months.		
MAX/MIN DISPLAY	Max/min readings are stored until reset by the user or when power to the meter is turned off. User can reset by front panel pushbuttons or via Modbus registers.		
PASSWORD	Programmable password restricts modification of programmed settings.		
NON-VOLATILE MEMORY	All programmed settings are stored in non-volatile memory for a minimum of ten years, with or without power.		
POWER	AC: 85-265 VAC, 50/60 Hz DC: 90-265 VDC Optional: 12-36 VDC, 12-24 VAC	Model	Watts
		PD865-6R2-06	6
		PD865-6R5-16	8
		PD865-6R7-16	15
		PD865-7R5-06	10
		PD865-7R7-06	10
REQUIRED FUSE	UL Recognized, 5 A max, slow-blow; up to 6 meters may share one fuse.		
ISOLATED TRANSMITTER POWER SUPPLY	One transmitter power supply (Optional) 24 VDC \pm 10% @ 200 mA max. (-1 option)		
ISOLATION	4 kV input/output-to-power line 500 V input-to-output or output-to-24 VDC supply		

ENVIRONMENTAL	Operating temperature range: -40 to 65°C Storage temperature range: -40 to 85°C Relative humidity: 0 to 90% non-condensing
CONNECTIONS	Removable screw terminal blocks accept 12 to 22 AWG wire.
ENCLOSURE	1/8 DIN, high impact plastic, UL 94V-0, color: gray
MOUNTING	1/8 DIN panel cutout required. Two panel mounting bracket assemblies provided
TIGHTENING TORQUE	Screw terminal connectors: 4.5 lb-in (0.5 Nm)
OVERALL DIMENSIONS	2.45" x 4.68" x 4.19" (62 mm x 119 mm x 106 mm) (H x W x D)
WEIGHT	8.0 oz (227 g) (2 relays) 9.7 oz (275 g) (4 relays, 4-20mA Output & 24 V supply)
WARRANTY	3 years parts and labor

Operating Modes

MASTER	Processes data read from a Modbus RTU slave device (only one process variable at a time can be displayed on the master). Proxy polling feature: Polls up to 8 process variables from up to 8 slave devices. The Master processes and displays PV1 and allows other PD865s in Snooper mode to read any of the variables being polled.
SLAVE	Processes data sent to it from a Modbus RTU master device.
SNOOPER	Listens to the Modbus traffic and picks up a specific register or registers being polled by a Master device from a specific slave device and processes the data being read. Note: The relays and the 4-20 mA output are functional in all modes.

Programmable Features for Master Mode

FUNCTION CODE	Select which Modbus function code (03 or 04) to use in reading the slave device.
NUMBER OF PVs	Select the number of process variables to be polled by the Master (PV1-PV8).
SLAVE ID	Assign the slave ID or address (1-247) containing the process variables to be displayed (Slave ID for PV1-8).
REGISTER NUMBER	5 digit: 30001-39999 or 40001-49999 6 digit: 300001-365536 or 400001-465536 Specifies which register(s) to read in the slave device. Range is dependent on Function Code selection (04 or 03) and digits selection (5 or 6). PV2-PV8: Select 1 register for Short integer or 2 registers for Long integer and Floating point data types.
DATA TYPE	Select the data format that the slave device uses. Select between Short integer (2 byte) and Long integer (4 byte) or floating point (4 byte), Signed or Unsigned (integer only) and byte order (big-endian vs. little-endian).
POLL TIME	0.1 to 25.5 sec. Time between read-commands (Master mode) or listening-time window (Snooper mode).
SLAVE RESPONSE TIMEOUT	0 to 25.4 seconds X3 (76.2 sec). Time allowed for the slave to respond to a command. Programming 0 disables the timeout. This setting is used by Master and Slave modes.

Serial Communications

SLAVE ID OR ADDRESS	1 – 247. Specifies the ID or address of the slave device (Master or Snooper mode) or the address of the PD865 (Slave mode).
BAUD RATE	300 – 19,200 bps
DATA	8 bit (1 start bit, 1 or 2 stop bits)
PARITY	None, even, or odd. 1 or 2 stop bits selectable for None.
BYTE-TO-BYTE TIMEOUT	0.01 – 2.54 seconds
TURN AROUND DELAY	Less than 2 ms (fixed)

Display Functions

INTENSITY	1 to 8. To optimize viewing based on ambient lighting conditions.
DISPLAY DECIMAL POINT	Up to five decimal places: <i>d.dddddd</i> , <i>dd.ddddd</i> , <i>ddd.dddd</i> , <i>dddd.dd</i> , <i>dddddd.d</i> , or <i>ddddddd</i>
FLOAT DECIMAL POINT	Select the number of decimals to use for the floating point data expected from the slave or master device (this is independent from the display decimal point selection).
MATH FUNCTIONS	Linear, square root, or programmable exponent (0.50000 to 2.99999).
MULTIPOINT SCALING	2 to 16 points.
NOISE FILTER	Programmable from 2 to 199 (0 will disable filter)
BYPASS	0.2 to 99.9% of full-scale.
CUTOFF	0 to 999999. 0 disables cutoff.

Relays

RATING	Standard: 2 relays, SPST (Form A) Optional: 2 relays, SPDT (Form C) All relays are rated 3 A @ 30 VDC or 3 A @ 250 VAC, resistive loads.
ELECTRICAL NOISE SUPPRESSION	A suppressor (snubber) should be connected to each relay contact switching inductive loads to prevent disruption to the microprocessor's operation. Recommended suppressor value: 0.01 μ F/470 Ω , 250 VAC (PDX6901).
DEADBAND	0-100% of full scale, user selectable
HIGH OR LOW ALARM	User may program any alarm for high or low trip point.
RELAY OPERATION	Automatic (non-latching) Latching Pump alternation control (up to 4 relays)
RELAY RESET	User selectable via front panel buttons or Modbus control Automatic reset only (non-latching) Automatic + manual reset at any time (non-latching) Manual reset only, at any time (latching) Manual reset only after alarm condition has cleared (latching) Automatic reset: Relays will automatically reset when the input passes the reset point. Manual reset: Front panel ACK button. Pressing ACK resets all manually resettable relays.
TIME DELAY	0 to 199 seconds, on and off delays Programmable and independent for each relay
FAIL-SAFE OPERATION	Programmable Independent for each relay
COMMUNICATIONS BREAK	No change, Relay on, or Relay off. Controls the condition the relay goes to when a slave device does not reply (Available also in Slave mode v1.1 & up).
AUTO INITIALIZATION	When power is applied to the meter, relays will reflect the state of the input to the meter.

Fail-safe operation: relay coil is energized in non-alarm condition. In case of power failure, relay will go to alarm state.

Isolated 4-20 mA Transmitter Output

CALIBRATION	Factory calibrated for 4-20 mA		
SCALING RANGE	1.000 to 23.000 mA for any display range. Reverse scaling allowed.		
ACCURACY	$\pm 0.1\%$ F.S. ± 0.004 mA		
TEMPERATURE DRIFT	50 PPM/ $^{\circ}$ C from 0 to 65 $^{\circ}$ C ambient		
EXTERNAL LOOP POWER SUPPLY	35 VDC maximum		
OUTPUT LOOP RESISTANCE	Power supply	Minimum	Maximum
	24 VDC	10 Ω	700 Ω
	35 VDC (external)	100 Ω	1200 Ω
DATA SOURCE	Display Value, Maximum Display Value, Minimum Display Value, or Modbus Register.		
OVERRANGE	Programmable mA output for overrange condition.		
UNDERRANGE	Programmable mA output for underrange condition.		
COMMUNICATIONS BREAK	Programmable mA output when a slave device does not reply within the Slave Response Timeout (Available also in Slave mode v1.1 & up).		
MAXIMUM OUTPUT	Programmable absolute maximum mA output desired.		
MINIMUM OUTPUT	Programmable absolute minimum mA output desired.		

COMPLIANCE INFORMATION

Safety

UL LISTED	USA and Canada UL 508 Industrial Control Equipment
UL FILE NUMBER	E160849
FRONT PANEL	UL Type 4X, NEMA 4X, IP65; panel gasket provided

SAFETY INFORMATION



CAUTION: Read complete instructions prior to installation and operation of the meter.



WARNING: Risk of electric shock or personal injury.



Warning!

***Hazardous voltages exist within enclosure.
Installation and service should be performed only by
trained service personnel.***

INSTALLATION

There is no need to remove the meter from its case to complete the installation, wiring, and setup of the meter.

Unpacking

Remove the meter from box. Inspect the packaging and contents for damage. Report damages, if any, to the carrier.

If any part is missing or the meter malfunctions, please contact your supplier or the factory for assistance.

Panel Mounting

- Prepare a standard 1/8 DIN panel cutout – 3.622" x 1.772" (92 mm x 45 mm). Refer to Figure 1 for more details.
- Clearance: allow at least 4" (102 mm) behind the panel for wiring.
- Panel thickness: 0.04" - 0.25" (1.0 mm - 6.4 mm).
Recommended minimum panel thickness to maintain Type 4X rating: 0.06" (1.5 mm) steel panel, 0.16" (4.1 mm) plastic panel.
- Remove the two mounting brackets provided with the meter (back-off the two screws so that there is 1/4" (6.4 mm) or less through the bracket. Slide the bracket toward the front of the case and remove).
- Insert meter into the panel cutout.
- Install mounting brackets and tighten the screws against the panel.
To achieve a proper seal, tighten the mounting bracket screws evenly until meter is snug to the panel along its short side. **DO NOT OVER TIGHTEN**, as the rear of the panel may be damaged.

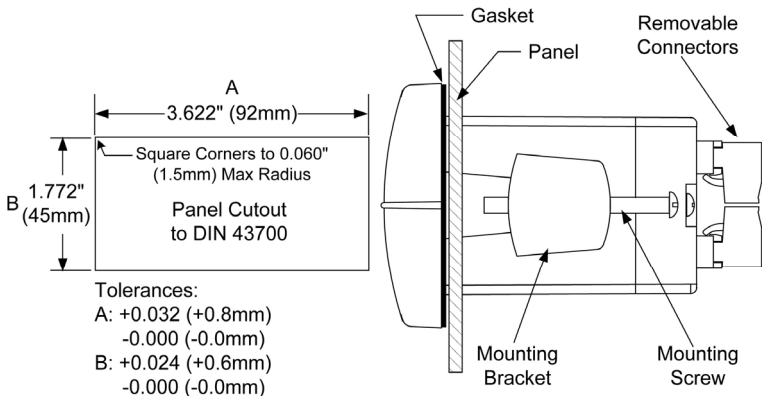
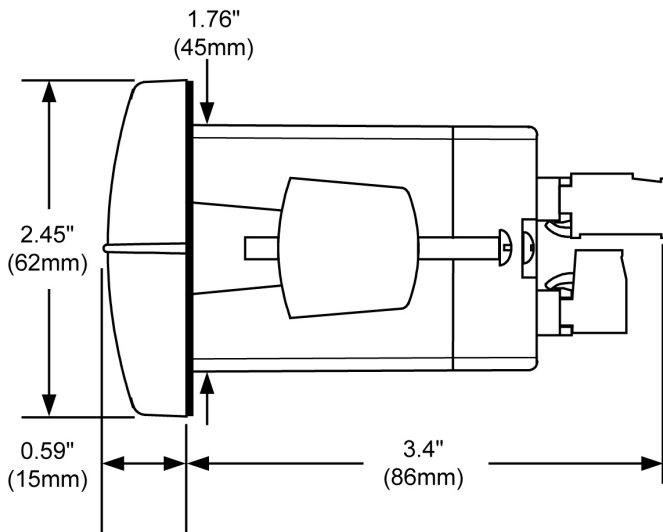

Figure 1: Panel Cutout and Mounting

MOUNTING DIMENSIONS



865SideViewDim

Figure 2: Meter Dimensions – Side View

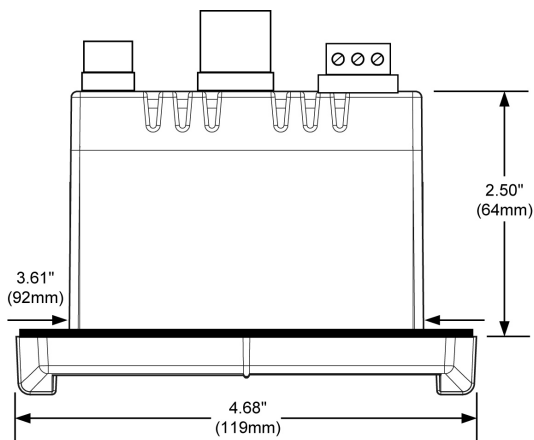



Figure 3: Case Dimensions – Top View

Connections

All connections are made to removable screw terminal connectors located at the rear of the meter.



Caution! Use copper wire with 60°C or 60/75°C insulation for all line voltage connections. Observe all safety regulations. Electrical wiring should be performed in accordance with all applicable national, state, and local codes to prevent damage to the meter and ensure personnel safety.

Connector Labeling

The connectors' label, affixed to the meter, shows the location of all connectors available with requested configuration.

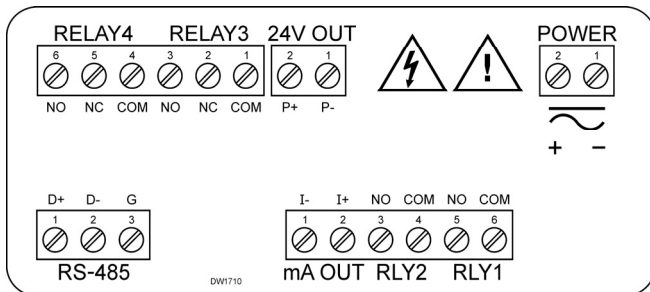

**Figure 4: Connector Label: 4 Relays,
4-20 mA Out & 24 V Supply**

Power Connections

Power connections are made to a two-terminal connector labeled POWER in Figure 2. The meter will operate regardless of DC polarity connection. The + and - symbols are only a suggested wiring convention.

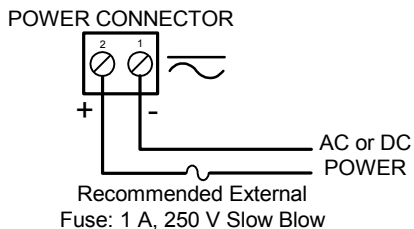

Figure 5: Power Connections

Serial Connections

The PD865 is connected to an RS-485 bus with up to 32 nodes. For systems consisting of more than 32 nodes, RS-485 repeaters are necessary. Wiring connections to the PD865 are made via the three position screw terminal connector labeled RS-485. Please refer to the EIA-485 standard for complete specifications for balanced digital multi-point communications. The use of shielded twisted pair cable is recommended to protect the data signals from electrical interference. For long wire runs it is good practice to terminate the bus at both ends with a resistor connected between D+ and D- that matches the characteristic impedance of the cable. A typical termination resistor value is 120 Ω .

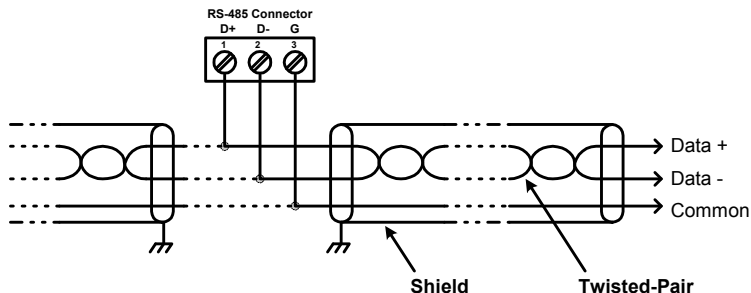

Figure 6: RS-485 Connection

For point-to-point (non-multipoint) serial communications with RS-232 data communications equipment (e.g. a personal computer), an RS-232 to RS-485 converter (e.g. the Precision Digital PDA7485) is required. When using the PDA7485, connect the PD865 according to the PDA7485 wiring diagram for a two wire RS-485 application.

Relay Connections

Connections to the two, standard Form A relays, are made to the connector labeled RLY1 and RLY2. See Figure 5. Connections to the two optional Form C relays are made to the six-terminal connector labeled RELAY3 and RELAY4.



Figure 7: Standard and Optional Relay Connectors

Switching Inductive Loads

The use of suppressors (snubbers) is strongly recommended when switching inductive loads to prevent disrupting the microprocessor's operation. The suppressors also prolong the life of the relay contacts. Suppression can be obtained with resistor-capacitor (RC) networks assembled by the user or purchased as complete assemblies. Refer to the following circuits for RC network assembly and installation:

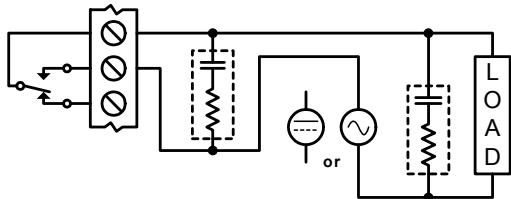

Figure 8: AC and DC Loads Protection

Choose R and C as follows:

R: 0.5 to 1 Ω for each volt across the contacts.

C: 0.5 to 1 μF for each amp through closed contacts.

Notes:

1. Use capacitors rated for 250 VAC.
2. RC networks may affect load release time of solenoid loads. Check to confirm proper operation.
3. Install the RC network at the meter's relay screw terminals. An RC network may also be installed across the load. Experiment for best results.
4. For low voltage DC loads, place a diode across the load with a reverse breakdown voltage two to three times the circuit voltage and a forward current at least as large as the load current. Shown in Figure 9

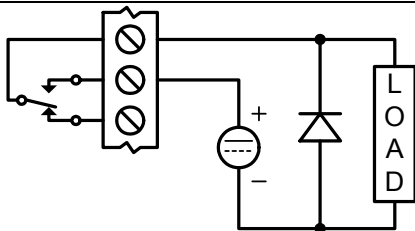

Figure 9: Low Voltage DC Loads Protection

RC Networks Available from Precision Digital

RC networks are available from Precision Digital and should be applied to each relay contact switching an inductive load. Part number: PDX6901.

Note: Relays are de-rated to 1/14th HP (50 watts) with an inductive load.

4-20 mA Output Connections

Connections for the 4-20 mA transmitter output are made to the connector terminals labeled “mA OUT, I-, I+”. The 4-20 mA output may be powered from an internal power supply (optional) or from an external power supply.

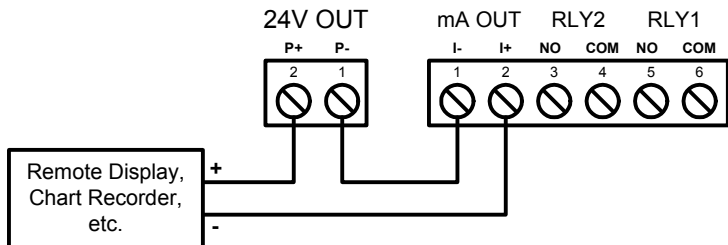

Figure 10: 4-20 mA Output Powered by Meter

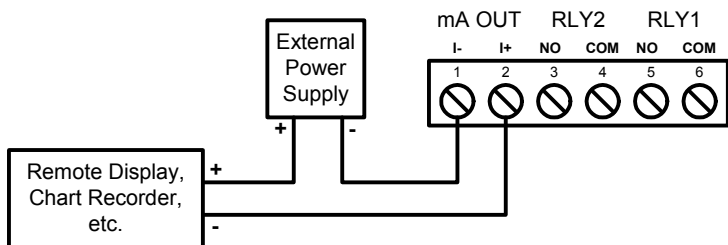

Figure 11: 4-20 mA Output Powered Externally

SETUP AND PROGRAMMING

- There is **no need to recalibrate** the 4-20 mA output (when installed) as received from the factory.
- The 4-20 mA output is **factory calibrated** prior to shipment. The calibration equipment is certified to NIST standards.

Overview





There are no jumpers involved in the meter setup procedure.

Setup and programming is done through the front panel buttons.

After power and signal connections have been completed and verified, apply power to the meter.

Front Panel Buttons and Status LED Indicators



Button Symbol	Description
	Menu
	Right arrow/Reset
	Up arrow/Max
	Enter/Ack

LED	Status
1	Alarm 1
2	Alarm 2
3	Alarm 3
4	Alarm 4
S	Set point indicator
R	Reset point indicator

- Press the **Menu** button to enter or exit the Programming Mode at any time.
- Press the **Right** arrow button to move to the next digit during digit programming.
- Press the **Up** arrow button to scroll through the menus, decimal point, or to increment the value of a digit.
- Press the **Enter/Ack** button to access a menu, to accept a setting, or to acknowledge a relay.
- Press and hold the **Right** arrow and the **Menu** buttons, for three seconds, to access the Advanced features of the meter (Tip: press and hold **Right** arrow first then **Menu**).
- See page 62 to display maximum and minimum readings.

Display Functions and Messages

The meter displays various functions and messages during setup/programming and operation. The following table shows the displayed functions and messages with their action/setting description.

Display	Parameter	Action/Setting
Mode	Mode	Enter the <i>Mode</i> menu.
Master	Master	Select <i>Master</i> Mode.
Function Code	Function Code	Enter the <i>Function Code</i> menu for Master or Snooper mode.
Function Code 03	Function Code 03	Use <i>Function Code 03</i> to read slave device.
Function Code 04	Function Code 04	Use <i>Function Code 04</i> to read slave device.
Number of PVs	Number of PVs	Enter the <i>Number</i> of PVs to be read from the slave device(s).
Slave ID	Slave ID	Enter the <i>Slave ID</i> menu for Master and Snooper modes. Enter the Slave ID or address for Slave mode.
Slave ID 1	PV1 ID	Enter the Slave ID or address for PV1.
Slave ID 2	PV2 ID	Enter the Slave ID or address for PV2.
Slave ID 3	PV3 ID	Enter the Slave ID or address for PV3.
Slave ID 4	PV4 ID	Enter the Slave ID or address for PV4.
Slave ID 5	PV5 ID	Enter the Slave ID or address for PV5.
Slave ID 6	PV6 ID	Enter the Slave ID or address for PV6.
Slave ID 7	PV7 ID	Enter the Slave ID or address for PV7.
Slave ID 8	PV8 ID	Enter the Slave ID or address for PV8.
Register Number	Register Number	Enter the <i>Register Number</i> menu.
Register 1	PV1 Register	Enter the Register Number for PV1.
Register 2	PV2 Register	Enter the Register Number for PV2.
Register 3	PV3 Register	Enter the Register Number for PV3.

Display	Parameter	Action/Setting
rEGPV4	PV4 Register	Enter the Register Number for PV4.
rEGPV5	PV5 Register	Enter the Register Number for PV5.
rEGPV6	PV6 Register	Enter the Register Number for PV6.
rEGPV7	PV7 Register	Enter the Register Number for PV7.
rEGPV8	PV8 Register	Enter the Register Number for PV8.
1-rEG	1 Register	Select 1 register for the assigned PV (short integer).
2-rEG	2 Registers	Select 2 registers for the assigned PV (long, float).
5 d iG 6 d iG	Reg. Numb. digits	Select either 5 (x0001-x9999) or 6 (x00001-x65536) digits for the Register Number by pressing the Right arrow in <i>Register Number</i> menu.
dAtE t	Data Type	Enter the <i>Data type</i> menu for PV1.
Short	Short Integer	Select <i>Short Integer</i> as the data type to be read from the slave device (PV1).
Long	Long Integer	Select <i>Long Integer</i> as the data type to be read from the slave device (PV1).
FLoAt	Floating Point	Select <i>Floating Point</i> as the data type to be read from the slave device (PV1).
bcd	BCD	Select <i>BCD</i> format for Short or Long integers.
binary	Binary	Select <i>Binary</i> format for Short or Long integers.
unsigned	Unsigned	Select <i>Unsigned</i> Binary format for Short or Long integers.
signed	Signed	Select <i>Signed</i> Binary format for Short or Long integers.
1234	Byte Order	Select big-endian byte order.
4321	Byte Order	Select little-endian byte order.

Display	Parameter	Action/Setting
2 143	Byte Order	Select byte-swapped big-endian byte order. Not available for Short integer.
34 12	Byte Order	Select byte-swapped little-endian byte order. Not available for Short integer.
t-PoLL	Poll Time	Enter the time between read commands. In other words, how often the display is updated in Master mode or how long to wait for data in Snooper mode.
t-rESP	Slave Response Timeout	Enter the time allowed for a slave device to respond to a command. <i>This setting is applicable to Master and Slave modes.</i>
SLAVE	Slave	Select Slave mode.
SnooPr	Snooper	Select Snooper mode.
SEr iRL	Serial	Enter Serial menu.
bRud	Baud	Enter the Baud rate menu.
300	300 baud	Select 300 baud for all serial communications.
600	600 baud	Select 600 baud for all serial communications.
1200	1200 baud	Select 1200 baud for all serial communications.
2400	2400 baud	Select 2400 baud for all serial communications.
4800	4800 baud	Select 4800 baud for all serial communications.
9600	9600 baud	Select 9600 baud for all serial communications.
19200	19200 baud	Select 19200 baud for all serial communications.
PRr tY	Parity	Enter the Parity menu.
no	No parity	Select No parity.
1 St0P	1 Stop bit	Select 1 stop bit with no parity
2 St0P	2 Stop bits	Select 2 stop bits with no parity
EUEn	Even parity	Select Even parity.
odd	Odd parity	Select Odd parity.
t-bytE	Byte-to-byte timeout	Enter the timeout value allowed between received bytes.
Pr0G	Program	Enter the Programming menu.

Display	Parameter	Action/Setting
d .5P.dP	Display Decimal Point	Set the decimal point position for the display. This is independent from float decimal point.
FLot.dP	Float Decimal Point	Select the decimal point for the expected floating point data.
ScALE	Scale	Enter the <i>Scaling</i> menu.
inP 1	Input Point 1	Enter the <i>Input</i> value for point 1. Up to 16 points can be entered in Linear mode.
d 5 1	Display Point 1	Enter the <i>Display</i> value for point 1. Up to 16 points can be entered in Linear mode.
SAVE P	Save?	Press Enter to save scaling data. Press Menu to exit without saving.
rELAY	Relay	Enter the <i>Relay</i> menu.
rLY 1	Relay1	<i>Relay 1</i> setup. Similar menus for Relays 2 to 4 are not shown here.
Rct 1	Action1	Set relay 1 <i>action</i> (automatic, latching, etc.).
Ruto	Automatic	Set relay for <i>automatic</i> reset.
R-mARn	Auto- manual	Set relay for <i>automatic + manual</i> reset any time.
LRECH	Latching	Set relay for <i>latching</i> operation.
Lt-CLr	Latching- cleared	Set relay for <i>latching</i> operation with manual reset only after alarm condition has cleared.
RLtErn	Alternate	Set relays for pump alternation control.
oFF	Off	Disable relay and front panel status LEDs. Disable relay fail-safe operation.
SEt 1	Set1	Program <i>set</i> point for Relay 1.
rSt 1	Reset1	Program <i>reset</i> point for Relay 1.
FR .LSF	Fail-safe	Enter <i>Fail-safe</i> menu.
FLS 1	Fail-safe1	Set relay 1 <i>fail-safe</i> operation. Similar menus for Relays 2 to 4 are not shown here.
on	On	Enable fail-safe operation.
oFF	Off	Disable fail-safe operation.
dELAY	Delay	Enter <i>Time Delay</i> menu.

Display	Parameter	Action/Setting
dLY 1	Relay 1 Delays	Enter relay 1 time <i>delay</i> setup. Similar menus for Relays 2 to 4 are not shown here.
on 1	Relay 1 On Delay	Set relay 1 <i>On</i> time-delay.
oFF 1	Relay 1 Off Delay	Set relay 1 <i>Off</i> time-delay.
brERP	Communica tions Break Action	Enter <i>Communications Break</i> menu.
brERP 1	Relay 1 Break Action	Enter Relay 1 <i>Break Action</i> . Similar menus for Relays 2 to 4 are not shown here.
no Act	No Action	No change in Relay state when Communications Break detected.
oFF	Off Action	Relay turns <i>off</i> when Communications Break detected.
on	On Action	Relay turns <i>on</i> when Communications Break detected.
Rout	Analog Output Scaling	Enter the <i>Analog Output</i> Scaling menu.
d 5 1	Display 1	Program the first <i>Display</i> value for the Analog Output.
out 1	Output 1	Program the first <i>Output</i> value that corresponds to the Display 1 value for the Analog Output.
d 5 2	Display 2	Program the second <i>Display</i> value for the Analog Output.
out 2	Output 2	Program the second <i>Output</i> value that corresponds to the Display 2 value for the Analog Output.
PR55	Password	Enter the <i>Password</i> menu.
unLoC	Unlocked	Meter is <i>unlocked</i> . Program password to lock meter.
LoCd	Locked	Meter is <i>locked</i> . Enter password to unlock meter.
999999 - 199999	Flashing display	<i>Overrange</i> condition and <i>Underrange</i> conditions.

Main Menu

The main menu consists of the most commonly used functions: *Mode*, *Serial*, *Program*, and *Password*.

- Press **Menu** button to enter Meter Programming then press **Up** arrow button to scroll through the main menu.

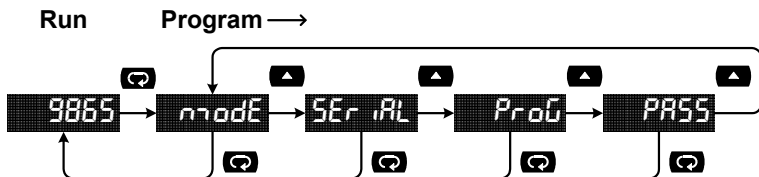

- Press **Menu** at any time, to exit and return to Meter Run. Changes made to settings prior to pressing **Enter/Ack** are not saved.
- Changes to the settings are saved to memory only after pressing **Enter/Ack**.
- The display automatically moves to the next menu every time a setting is accepted by pressing **Enter/Ack**.

Setting Numeric Values

The numeric values are set using the **Right** and **Up** arrow buttons. Press **Right** arrow to select next digit and **Up** arrow to increment digit value.

The digit being changed is displayed brighter than the rest.

Press the **Enter/Ack** button, at any time, to accept a setting or **Menu** button to exit without saving changes. Pressing **Menu** to exit while entering Scaling data does not save *any* of the Scaling data.

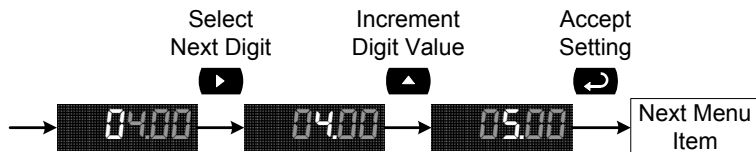

If a digit cannot be changed because it will cause an out of range value, the next digit will be selected automatically.

Go to the *Program-Decimal Point* menu to select the decimal point.

Meter Setup

Operating Modes (mode)

The *Mode* menu is used to select how the meter is to function:

1. Master: Reads a slave device, scales the data from it, displays the result, and operates the relays and 4-20 mA output.
Proxy polling feature: The Master polls from 1 to 8 process variables from 1 to 8 slave devices. The Master processes and displays PV1 and allows other PD865s in Snooper mode to read any of the variables being polled.
2. Slave: Read and controlled by a master device (PLC, DCS, etc). The data sent to it by the master is scaled, displayed, and used to operate the relays and 4-20 mA output. All parameters are accessible via the Slave Mode Register Table on page 69.
3. Snooper: Listens to the Modbus traffic and picks up a specific register or registers being polled by a Master device from a specific slave device and processes the data being read.

The Master mode requires additional parameter selection to specify how the slave device is to be read and how to interpret the data.

Press **Menu** to enter Meter Programming. Press the **Enter/Ack** button to access any menu or press **Up** arrow button to scroll through choices. Press the **Menu** button to exit at any time and return to Meter Run.

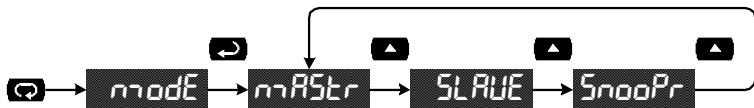

Master Mode (מאסטר)

The Master mode contains the following submenus: select which Function Code to use, the number of PVs to poll, the slave IDs and register numbers, the type and format of data for PV1, the slave Polling time and Response timeout.

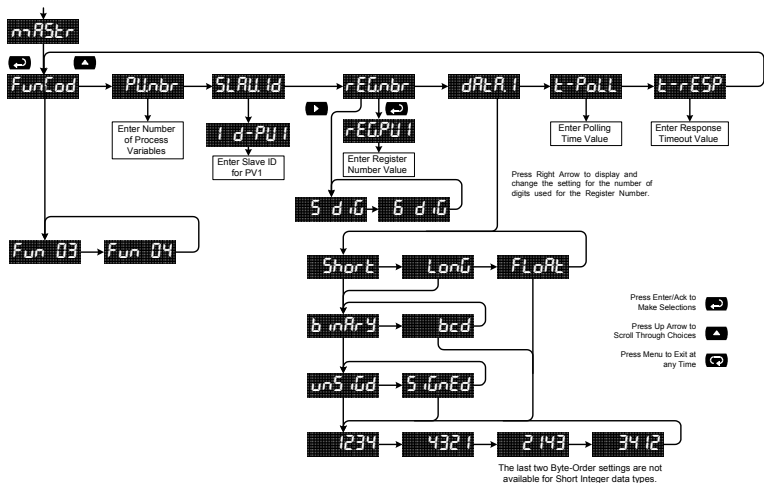

The Master ignores the decimal point setting for most slave devices that specify a Short or Long integer. For example, a slave that is displaying 12.34 is read as 1,234. Floating point data may or may not utilize the decimal point. Refer to the slave's operating manual to make sure.

The Register Number range is based on the Function Code and the number of digits selected. See the following table.

Function Code	5 Digit	6 Digit
03	40001 – 49999	400001 – 465536
04	30001 – 39999	300001 – 365536

Proxy Polling Mode

Proxy Polling mode is enabled when a number greater than 1 is entered in the *PVnbr* (number of PV's) menu. In this mode, the PD865 acts as a Master and polls up to an additional 7 slave devices, enabling other PD865s, operating in Snooper mode, to read and display that polled data. In Proxy Polling mode, the PD865 Master always displays PV1, the first value polled.

The baud rate for polling more than 2 variables should be set to be greater than 4800 bps. A faster baud rate will produce fewer communication errors and breaks.

Application Using Proxy Polling

In this application we have a system consisting of an MTS M-Series multivariable level gauge connected to three PD865s displaying Product Level, Interface Level, and Average Temperature.

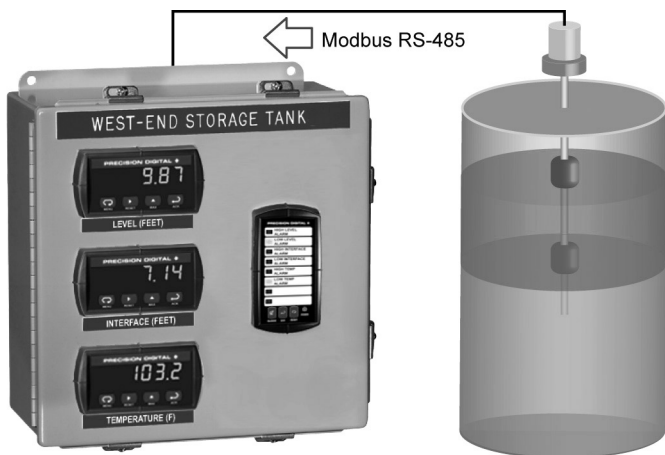

Register Numbers & Process Variables

30001 (40001) - Product Level

30003 (40003) - Interface Level

30017 (40017) - Average Temperature

PD865 Snooper Modbus Serial Input Meter **Instruction Manual**

The following table shows the system setup for the MTS M-Series gauge, the PD865 Master, and the two PD865 Snoopers:

Parameter	PD865 Master	PD865 Snooper 1	PD865 Snooper 2
Mode	Master	Snooper	Snooper
Function Code	04	04	04
Number of PVs	3	N/A	N/A
Slave ID		247	247
PV1	247		
PV2	247		
PV3	247		
Register Number		30003	30017
Reg.PV1	30001		
Reg.PV2	30003 (2 Reg.)		
Reg.PV3	30017 (2 Reg.)		
Data Type	Long integer Binary, Signed	Long	Long
Byte Order	1234	1234	1234
Polling Time	2.0 sec	10.0 sec	10.0 sec
Slave Response Timeout	5.0 sec	N/A	N/A
Baud	4800	4800	4800
Parity	No	No	No
Byte-to-Byte Timeout	0.01 sec	0.01 sec	0.01 sec
Decimal point	2 places	2 places	2 places
Input 1	-199999	-199999	-199999
Display 1	-1999.99	-1999.99	-1999.99
Input 2	999999	999999	999999
Display 2	9999.99	9999.99	9999.99

Slave Mode (SLAVE)

The Slave mode is capable of accepting Long and Float data types. Refer to the Slave Mode Register Table for details of all the predefined parameters.

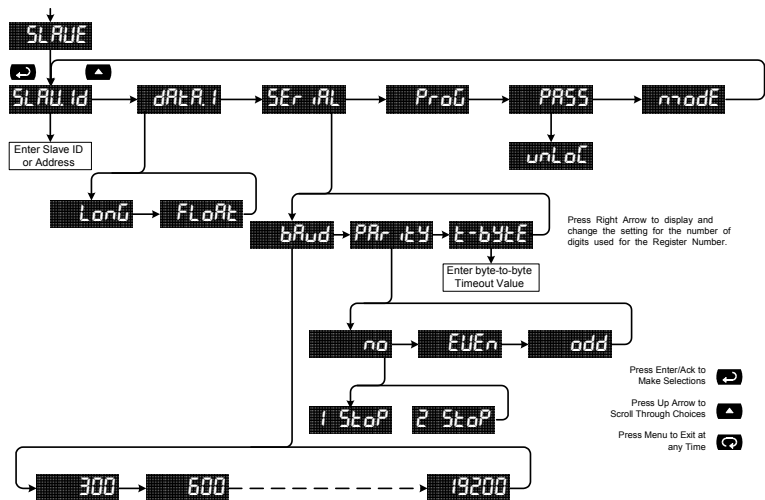

Snooper Mode (*SnooPr*)

The Snooper mode is used to listen to data being transmitted on the bus. Multiple Snoopers can be connected to the RS-485 bus and display any process variable. The same process variable can be displayed in multiple locations.

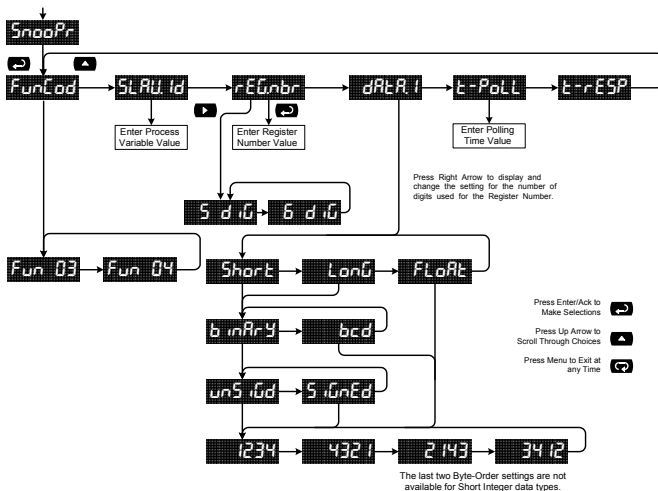

Notes:

1. To minimize the possibility of communication errors and communication break conditions, use a poll time of 5 seconds or more with slow baud rates (e.g. 4800 bps or less).
2. The poll time for meters set up for Snooper mode must be greater than the Master's poll time. This setting corresponds to the time window during which the Snooper listens to the bus for a reply by the slave device being polled by the master device. As soon as the Snooper detects a new reply on the bus, the display is updated. If there is no reply within the Poll Time setting, the Snooper goes into communications break condition.
3. The Slave Response Timeout (*t-rESP*) setting is not applicable to the Snooper mode.

Serial Communications (SErIAL)

The meter has an RS-485 interface. The baud rate, parity, and byte-to-byte timeout can be programmed.

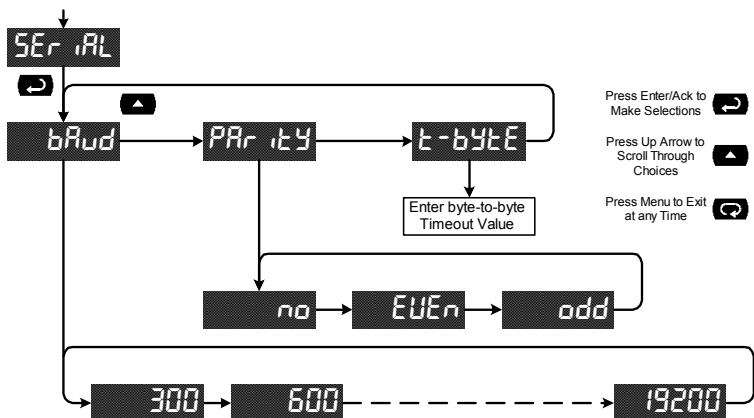
**Program Menu (Prog)**

The Programming menu contains the menus for Display Decimal Point (d.SP.dP), Scale, Relays, and Analog Output (4-20 mA).

Note: If Float data type has been selected, the program menu also contains a Float Decimal Point (FL.dP) selection.

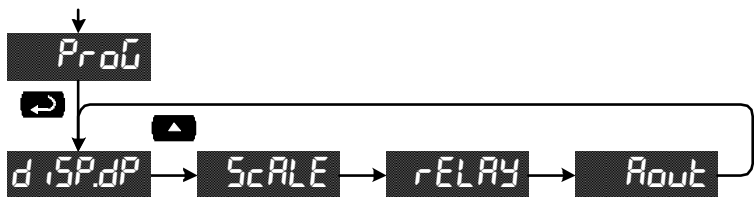

Setting the Display Decimal Point (*d.SP.dP*)

Decimal point may be set one to five decimal places or with no decimal point at all. Pressing the **Up** arrow moves the decimal point one place to the right until no decimal point is displayed, and then it moves to the leftmost position. The decimal point is programmable only for the Display Value.



Setting the Float Decimal Point (*FLot.dP*)

If floating point data type is selected, the *Float Decimal Point* menu is available. Select the number of decimals to correspond to the expected floating point data; the numbers to right of the LSD will be ignored by the meter.

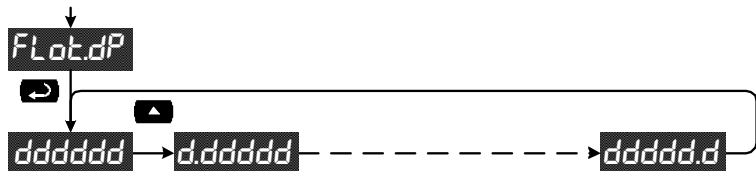

Example:

If you have a number such as *12.3456*, you have to tell the meter how many digits to the right are of interest to you. In this case selecting 4 places will make use of all the digits. For most applications the display decimal point will be set accordingly (*i.e.* 4 places).

If 2 decimal places are selected, the number *12.3456* is displayed as *12.35*; notice that the number is rounded up.

Scaling the Display Value (ScALE)

The data that the meter receives can be scaled to display in engineering units. Input 1 must be less than Input 2; Input 2 must be less than Input 3; etc (known as monotonic values). Press Menu after all changes have been made. The display will flash *ScALE* $\bar{\bar{}}$. Press **Enter** to save the changes or **Menu** to exit without saving. When the Linear function is selected, up to 16 points may be programmed to handle non-linear data. Only two points are available for either the Square Root or Programmable Exponent functions. See the Advanced Features/Display Math Function menu on page 54 for more information.



Only the programmed number of points will be shown in the menu. The range is from 2 to 16 points.

The display will alternate between *ERROR* and *RR--bb* if two inputs have the same value or are not monotonic, where *RR* and *bb* represent the two erroneous input points. Undesired operation may occur if the error is not corrected. Correct the error by either changing one of the inputs in question or changing the number of points to exclude an erroneous input point.

Note: *Data that is outside the working Input range will cause an out of range condition. For example, if 4 points are programmed, data less than Input 1 will cause an underrange and data greater than Input 4 will cause an overrange.*

Setting the Relay Operation (rELAY)

This menu allows you to set up the operation of the relays:

1. Relay action: Automatic reset only, Automatic + manual reset, Latching, Latching with Clear, Pump alternation control, Off.
2. Set point
3. Reset point
4. Fail-safe operation: On, Off.
5. Time delay: On delay, Off delay (both 0-199 seconds).
6. Communications Break Action: No Action, Off, On.

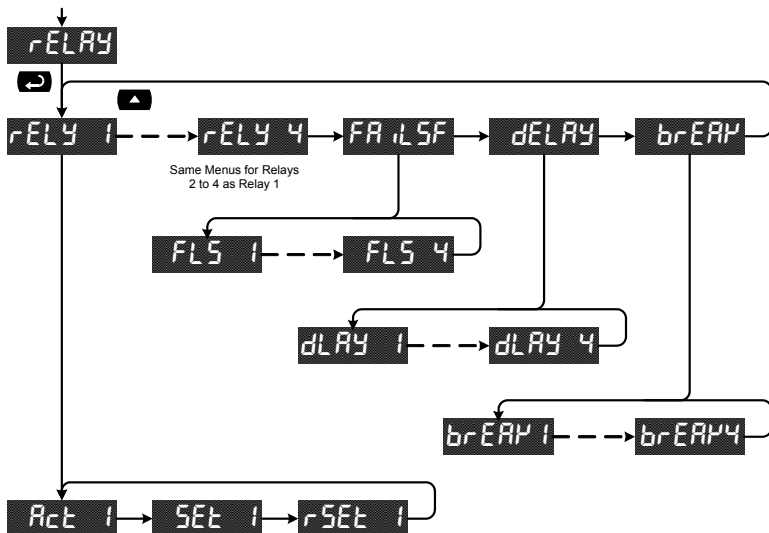

Refer to page 24 for a description of *Display Functions and Messages*

Setting the Relay Action

The relays *Action* menu allows the user to set up the operation of the relays. The relays may be set up for any of the following modes of operation:

1. Automatic reset (non-latching)
2. Automatic + manual reset at any time (non-latching)
3. Latching (manual reset only, at any time)
4. Latching with Clear (manual reset only after alarm condition has cleared)
5. Pump alternation control (automatic reset only)
6. Off (relay and status LED disabled)

The following graphic shows the action menu for relay 1. Relays 2 to 4 are set up in a similar fashion.

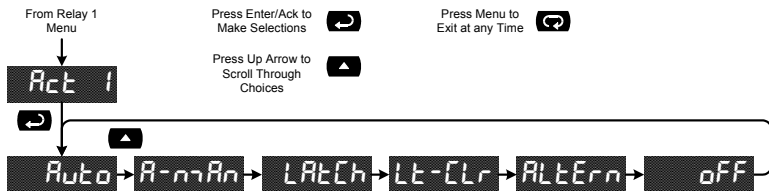

Programming Set and Reset Points

High alarm indication: program set point above reset point.

Low alarm indication: program set point below reset point.

The deadband is determined by the difference between set and reset points. Minimum deadband is one display count. If set and reset points are programmed the same, relay will reset one count below set point. The following graphic shows the Set/Reset point menu for relay 1. The menu is similar for relays 2 to 4.

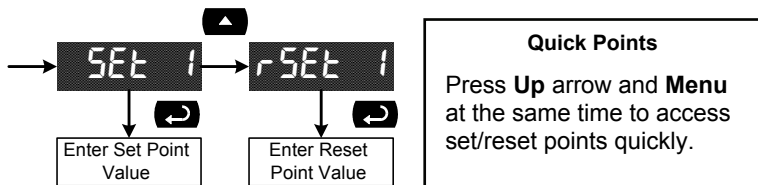

Setting Fail-Safe Operation

The fail-safe operation is set independently for each relay. Select **on** to enable or select **off** to disable fail-safe operation.

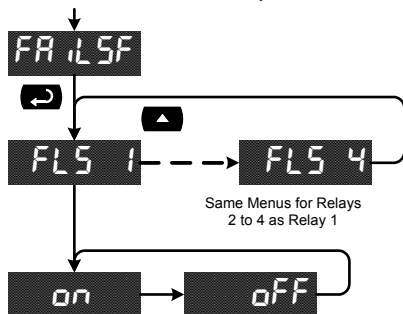

Programming the On and Off Time Delays

Each relay has an *On* and *Off* time delay that may be programmed between 0 and 199 seconds. The relays will transfer only after the condition has been maintained for the corresponding time delay.

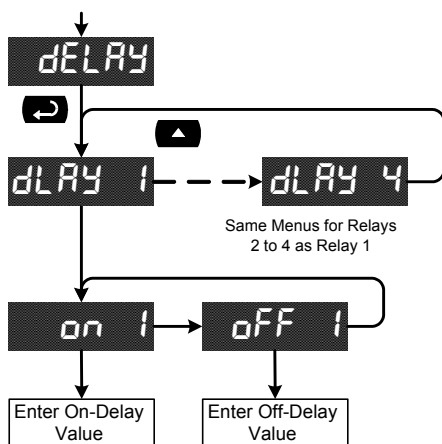

Relay and Alarm Operation

The following graphs illustrate the operation of the relays, status LEDs, and Acknowledge (ACK) button.

High Alarm Operation (Set > Reset)

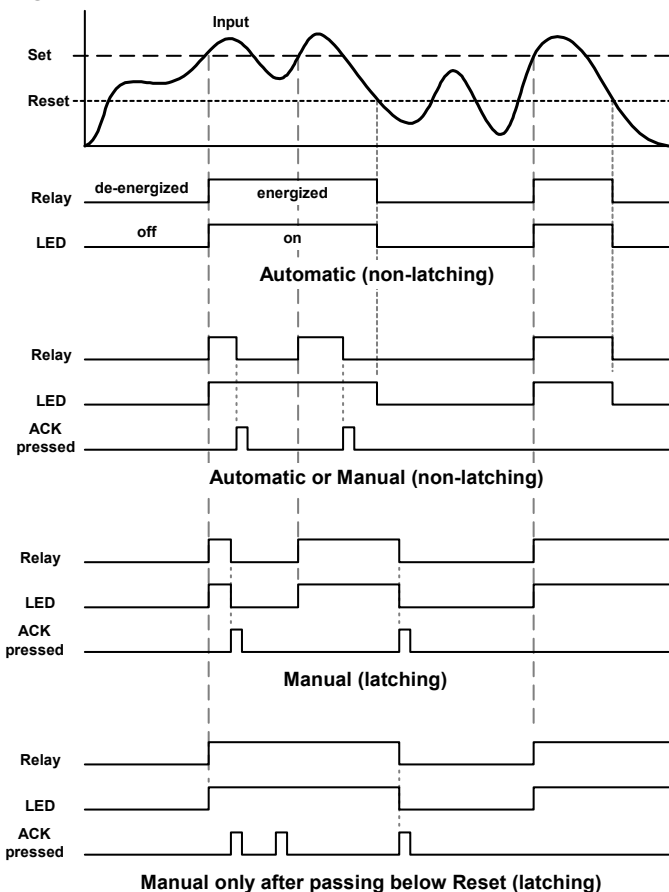

In Manual mode, ACK can be pressed anytime to turn the relay "off". For the relay to turn back "on", the signal must go below the set point, and then go above it.

Low Alarm Operation (Set < Reset)

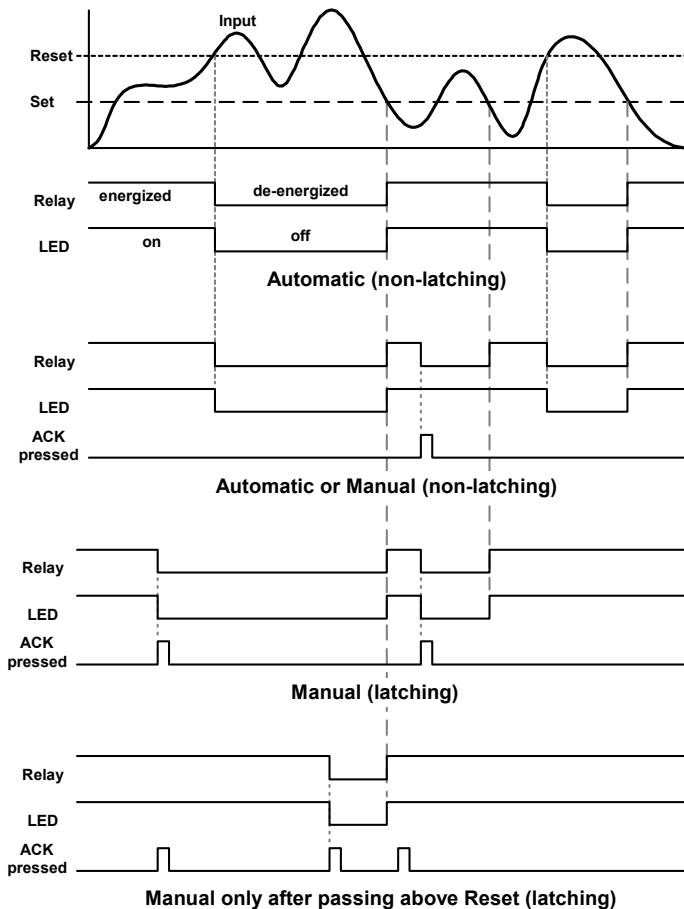

In Manual mode, ACK can be pressed anytime to turn the relay "off". For the relay to turn back "on", the signal must go above set point, and then go below it.

Time Delay Operation

The following graphs show the operation of the time delay function.

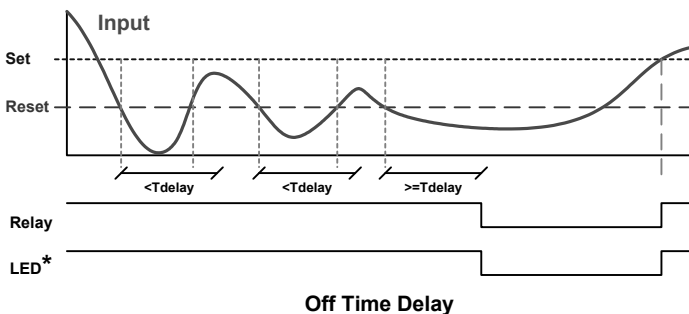
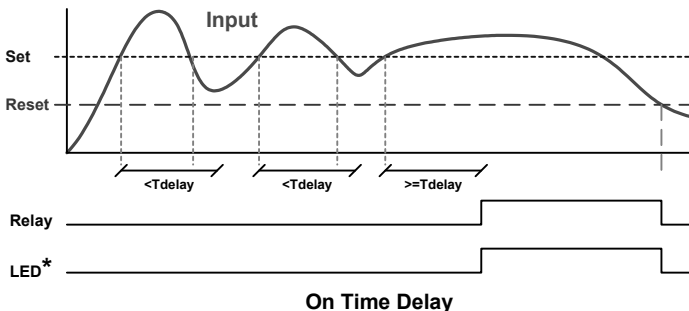

If the signal crosses the set point, the *On* time delay timer starts and the relay trips when the time delay has elapsed. If the signal drops below the set point (high alarm) before the time delay has elapsed, the *On* time delay timer resets and the relay does not change state. The same principle applies to the *Off* time delay.

* *Note: The LED is not affected by Time Delay when "Automatic or Manual" reset mode is selected. Rather the LED follows the set and reset points.*

High Alarm with Fail-Safe Operation (Set > Reset)

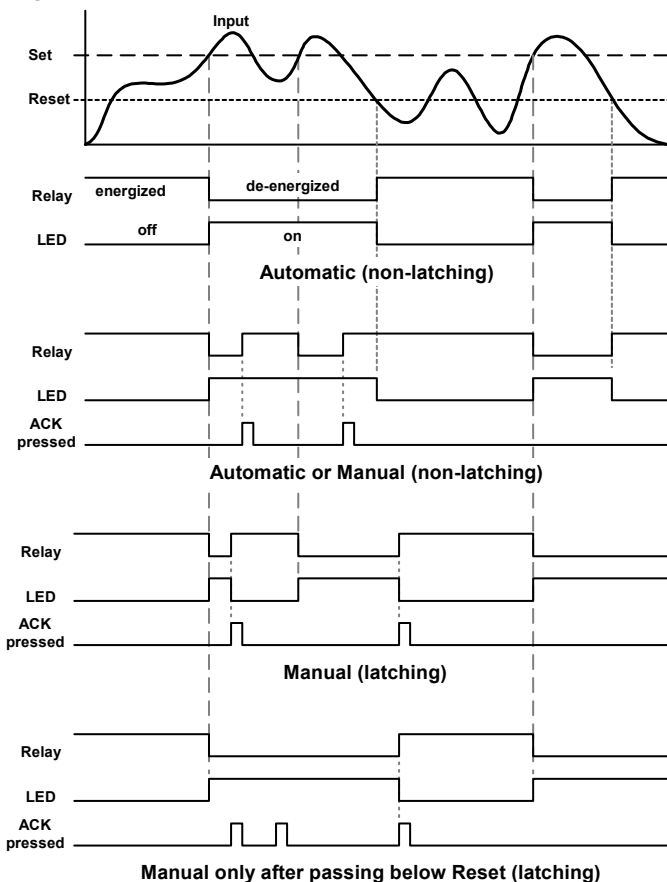

Fail-safe operation: relay coil is energized in non-alarm condition. In case of power failure, relay will go to alarm state.

Low Alarm with Fail-Safe Operation (Set < Reset)

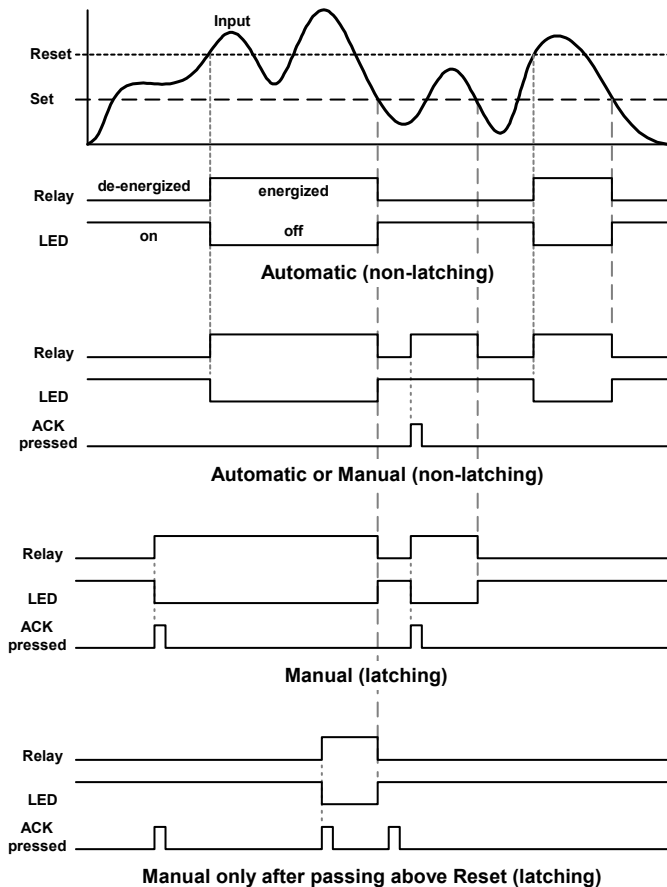

Fail-safe operation: relay coil is energized in non-alarm condition. In case of power failure, relay will go to alarm state.

Pump Alternation Example for 3 Relays

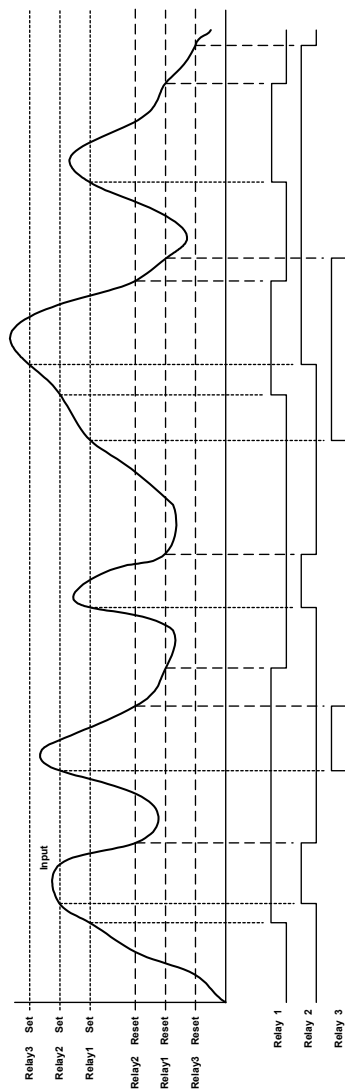
**Notes:**

1. LEDs indicate the relay status.
2. Any combination of 2 to 4 relays are available for alternating pump control.

Relay Operation After Communications Break

When a Master meter fails to receive a reply from the slave it is called a Communications Break. The relays can be programmed to react to this event by going On, Off, or No Action. After communications is restored the relays are turned off or on based on their operating mode and their set and reset points, without regard to their prior state. This is similar to the auto initialization on power up. Below is a diagram showing three examples.

The same is true for a meter set up to operate in Snooper mode.

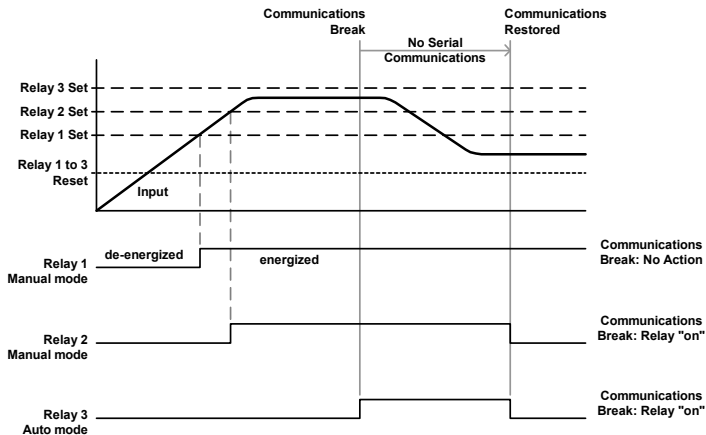

Scaling the 4-20 mA Analog Output (R_{out})

The 4-20 mA analog output can be scaled to provide a 4-20 mA signal for any display range selected. No equipment is needed to scale the analog output; simply program the display values to the corresponding mA output signal.

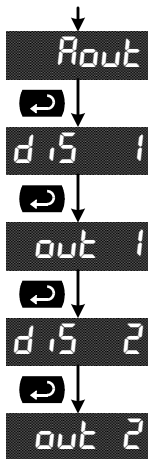

For instructions on how to program numeric values see *Setting Numeric Values*, page 29.

Setting Up the Password (PR55)

The *Password* menu is used to program a four-digit password to prevent unauthorized changes to the programmed parameter settings.

Locking the Meter

Enter the *Password* menu and program a four-digit password.

For instructions on how to program numeric values see *Setting Numeric Values*, page 29.

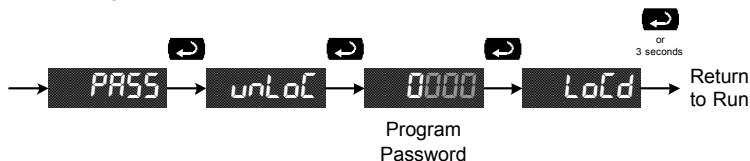

Record the password for future reference. If appropriate, it may be recorded in the space provided.

Model:	
Serial Number:	
Password:	— — — —

Unlocking the Meter

If the meter is password protected, the correct password must be entered in order to make changes to the parameter settings.

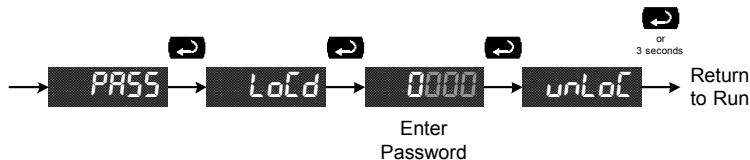

Entering the correct four-digit number sets the password to 0000, disabling the protection.

Changes to the programmed parameter settings are allowed only with the password set to 0000.

If the password entered is incorrect, the meter displays (Locked) for about two seconds, then it returns to Meter Run. To try again, press **Enter/Ack** while the *Locked* message is displayed.

Forgot the Password?

The password may be disabled by the following procedure:

1. Note display reading prior to pressing the Menu button. Ignore decimal point and sign.
2. Access the *Password* menu, add 2 to the noted reading and enter that number as the password (e.g. display reading = -1.23, password = 0125).

Advanced Features Menu

To simplify the setup process, functions not needed for most applications are located in the *Advanced Features* menu: *Display Function*, *Noise Filter*, *Noise Filter Bypass*, *Cutoff*, *Analog Output Programming*, *Display Intensity*, and *Information*.

- Press and hold the **Right** arrow and **Menu** buttons for three seconds to access the Advanced Features. (Tip: press and hold the **Right** arrow button first, then the **Menu** button). Press the **Up** arrow button to scroll through the advanced features menu.

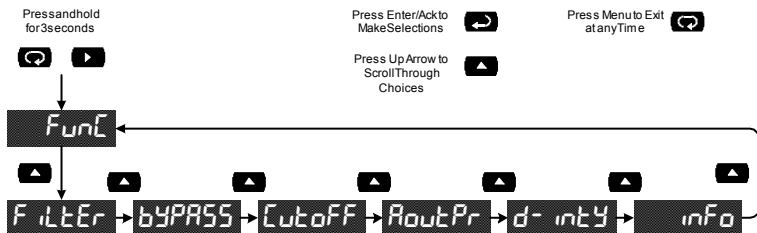

- Press **Menu** at any time, to exit and return to Meter Run. Changes made to settings prior to pressing **Enter/Ack** are not saved.
- Changes to the settings are saved to memory only after pressing **Enter/Ack**.
- The display automatically moves to the next menu every time a setting is accepted by pressing **Enter/Ack**.

Advanced Features Menu & Display Messages

Display	Parameter	Action/Setting
Func	Function	Enter <i>Display Function</i> menu.
Linear	Linear	Select <i>Linear</i> Display Function.
no Pts	Number of Points	Enter the <i>number of points</i> for Linear Display Function (2 to 16).
SqRt	Square Root	Select <i>Square Root</i> Display Function.
Prog E	Programmable Exponent	Select <i>Programmable Exponent</i> Display Function. Programmable from 0.50000 to 2.99999.
Filter	Filter	Set noise <i>filter</i> value.
bypass	Bypass	Set filter <i>bypass</i> value.
Cutoff	Cutoff	Set low-flow <i>cutoff</i> value.
OutPr	Analog Output Program	Enter <i>Analog Output Programmable</i> parameters menu.
Source	Analog Output Data Source	Enter Analog Output Data <i>Source</i> menu.
disP	Display Source	Select <i>Display</i> for Analog Output Data Source.
maxH	Maximum Display Source	Select <i>Maximum</i> Display value for Analog Output Data Source.
minH	Minimum Display Source	Select <i>Minimum</i> Display value for Analog Output Data Source.
reg	Register Source	Select Modbus <i>Register</i> for Analog Output Data Source.
Overrng	Overrange	Enter the Analog Output value for an <i>Overrange</i> condition.
Underrng	Underrange	Enter the Analog Output value for an <i>Underrange</i> condition.
brk	Communications Break	Enter the Analog Output value when <i>Communications Break</i> is detected. (Available also in Slave Mode v1.1 & up).
maxH	Max Analog Output	Enter the <i>maximum</i> value allowed for the Analog Output.

Display	Parameter	Action/Setting
0000	Min Analog Output	Enter the <i>minimum</i> value allowed for the Analog Output.
0000	Calibration	Enter the Analog Output <i>Calibration</i> menu.
0000	Manual	Perform a <i>manual</i> calibration on the Analog Output.
0000	Automatic	Perform an <i>automated</i> calibration on the Analog Output.
0000	Display Intensity	Set the <i>display intensity</i> .
0000	Information	Display software version and S/N <i>information</i> .

Display Math Function (Func)

The input data can be scaled using one of three selectable functions: Linear, Square Root, or Programmable Exponent.

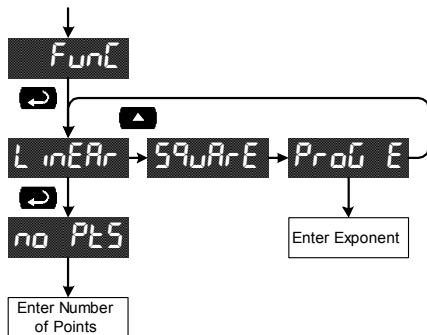

- Linear: The Linear function can be programmed to have from 2 to 16 points.
- The Square Root and Programmable Exponent functions have 2 points.
- The Programmable Exponent can be programmed from 0.50000 to 2.99999. Setting it to 0.50000 is the same as selecting the Square Root function.

Noise Filter (FILTER)

Most applications do not require changing this parameter. It is intended to help attain a steady display with an unsteady (noisy) input data.

The field selectable noise filter averages any minor or quick changes in the input data and displays the reading with greater stability.

Increasing the filter value will help stabilize the display, however this will reduce the display response to changes on the input data.

The filter level may be set anywhere from 2 to 199.

Setting the filter value to zero disables the filter function, and the bypass setting becomes irrelevant.

Noise Filter Bypass (BYPASS)

The meter can be programmed to filter small input changes, but allow larger input changes to be displayed immediately, by setting the bypass value accordingly.

If the input signal goes beyond the bypass value, it will be displayed immediately with no averaging done on it.

The noise filter bypass value may be set anywhere from 0.2 to 99.9.

Increasing the bypass value may slow down the display response to changes on the input signal.

Low-Flow Cutoff (LOWOFF)

The low-flow cutoff feature allows the meter to be programmed so that the often unsteady output from a differential pressure transmitter, at low flow rates, always displays zero on the meter.

The cutoff value may be programmed from 0 to 999999. When the input data is below the cutoff value, the meter will display zero. Programming the cutoff value to zero disables the cutoff.

Analog Output Programming (RoutPr)

The 4-20 mA analog output can be programmed for its source of data, overrange and underrange, absolute max and min output, and communications break values. It can also be calibrated manually or automatically.

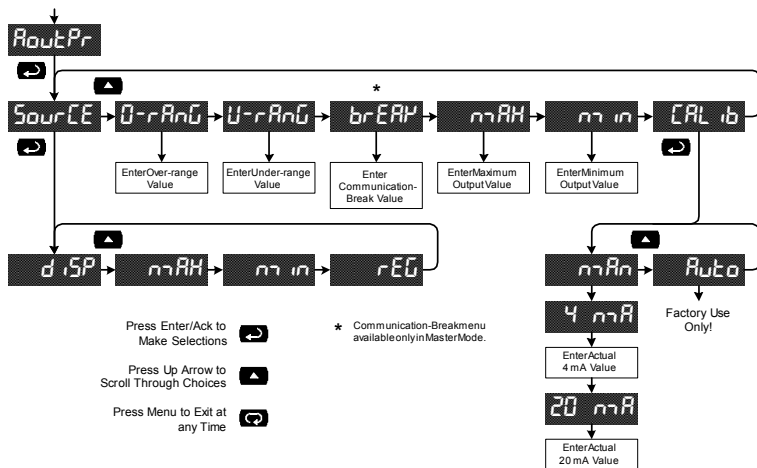

- The overrange and underrange values are the values that will be output when the display shows an overrange or underrange condition.
- The max and min values are the absolute limits for the 4-20 mA output.
- The communications break value determines the mA output when a slave fails to reply to a command within the Response time.
- For calibration instructions, see 4-20 mA Output Calibration, on page 57.

4-20 mA Output Calibration

- There is **no need to recalibrate** the 4-20 mA output when first received from the factory.
- The 4-20 mA output is **factory calibrated** prior to shipment. The calibration equipment is certified to NIST standards.

The 4-20 mA output can be calibrated in the field. A calibrated digital meter with an input range of at least 25 mA and a resolution of 1 μ A is recommended.



If an uncalibrated meter or a meter with less resolution is used, the calibration of the 4-20 mA output could be adversely affected.

4-20 mA Output Calibration Procedure

1. Wire the PD865 4-20 mA output to a current loop that includes a power supply (internal or external 12 to 24 VDC), and the current input on the digital meter.
2. Turn on all devices. Allow for a 15 to 30 minute warm-up.
3. Go to the Advanced Features menu, and navigate to the Analog Output (**אנלוג**)/Calibration (**CAL** **בו**) menu and press **Enter**. Select Manual calibration (**הארה**) and press **Enter**.
4. The display will show **4** **מא**. The PD865 mA output should now be close to 4 mA. Press **Enter** and the display will show **04.0000**. Enter the actual value read by the digital meter and press **Enter**.
5. The display will show **20** **מא**. The PD865 mA output should now be close to 20 mA. Press **Enter** and the display will show **20.0000**. Enter the actual value read by the digital meter and press **Enter**.
6. The PD865 will now calculate the calibration factors and store them.

Display Intensity (d-intY)

The Display Intensity function allows the selection of eight levels of intensity for various lighting conditions.

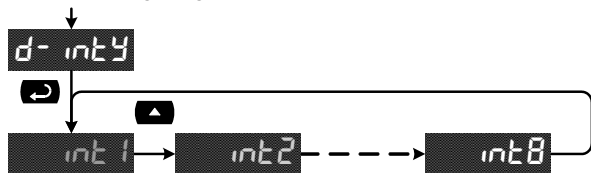
**Information (inFo)**

The Information menu shows the firmware, version, and serial numbers.

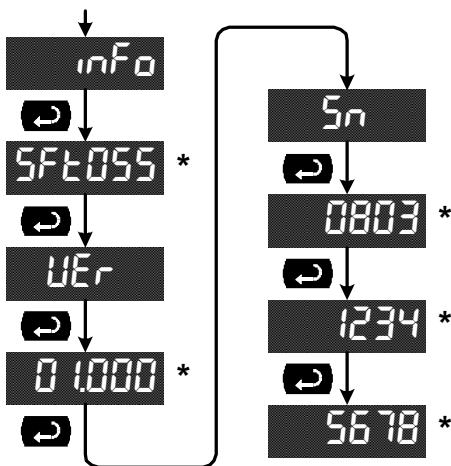

* These numbers are for illustration only. Actual values may vary from those shown. The serial number can be up to 16 characters long.

The serial number only displays numbers. If non-numeric characters are present, they will be displayed as underlines.

OPERATION

The PD865 meter is capable of operating as a Modbus Master, Slave or Snooper. As a Slave, the PD865 requires connection to a Master device: PLC, DCS, etc. As a Master, the PD865 interfaces up to eight slave devices. As a Snooper it can be connected anywhere in the RS-485 bus to read any of the variables being requested by the Master device.

Master and Slave Connections

The following figures show a few possible connection schemes.

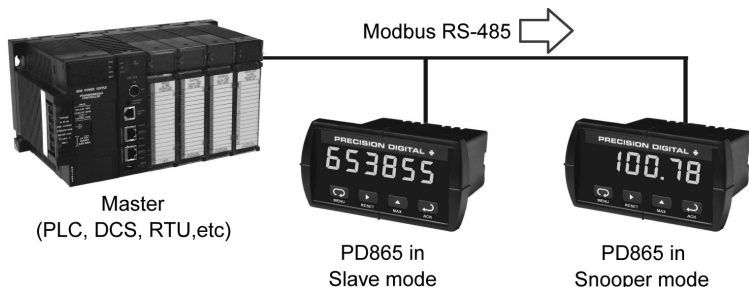

Figure 12: PD865 Slave & Snooper Connected to a Master

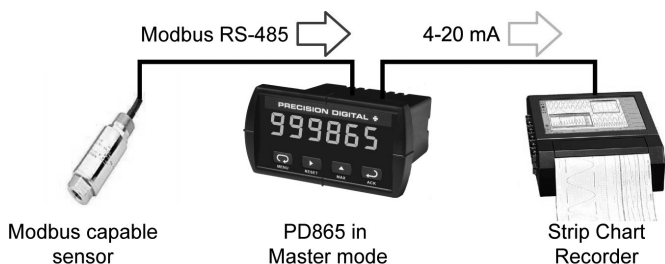

Figure 13: PD865 Master Connected to a Smart Sensor & Chart Recorder

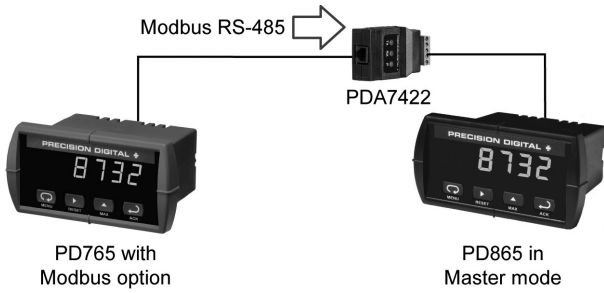

Figure 14: PD865 Master Connected to a PD765 Meter

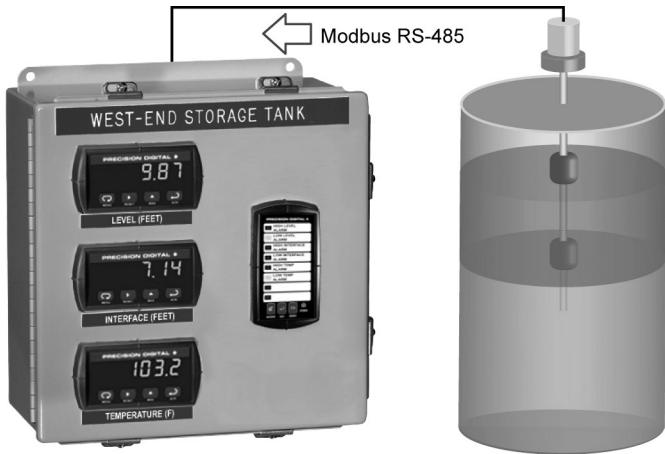

Figure 15: PD865 Master & Snoopers Connected to Multivariable Level Transmitters

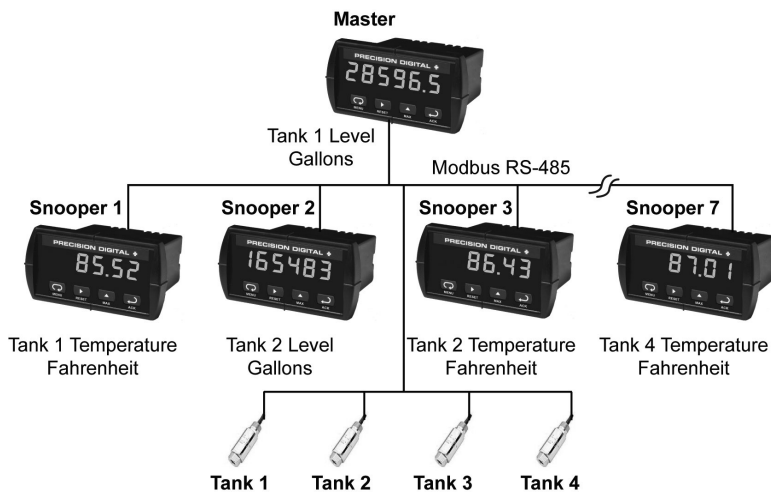
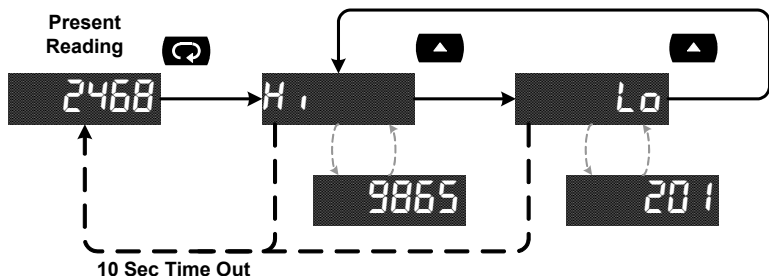

Figure 16: PD865 Master & Snoopers Connected to Level and Temperature Sensors

Maximum/Minimum Readings

The primary function of the front panel buttons during operation is to display the maximum and minimum readings reached by the process or temperature inputs.



1. Press **Up** arrow/**Max** button to display maximum reading since the last reset/power-up. The display will switch between **Hi** and the reading.
2. Press **Up** arrow/**Max** again to display the minimum reading since the last reset/power-up. The display will switch between **Lo** and the reading.
3. Press **Enter/Ack** to hold Max/Min display reading, the meter will continue to track new Max/Min readings.
4. If **Enter/Ack** is not pressed, the Max/Min display reading will time out after ten seconds and the meter will return to display the actual reading.
5. To reset the Max/Min value, press the **Right** arrow/**Reset** button while the Max/Min is being displayed. This will reset it to the present reading.

TROUBLESHOOTING

If the meter is not working as expected, refer to the troubleshooting tips on page 68.

Determining Software Version

To determine the software version of the meter:

1. Go to the *Information* menu (*INF0*) in the Advanced Features menu and press the **Enter/Ack** button.
2. Press **Enter/Ack** to access the software number (*5FL*), version (*UEr*), and serial number (*5n*) information. Write down the information as it is displayed. Continue pressing **Enter/Ack** until all the information is displayed.

Reset Meter to Factory Defaults

When the parameters have been changed in a way that is difficult to determine what is happening, it might be better to start the setup process from the factory defaults.

Instructions to load factory defaults:

1. Enter the *Advanced* features menu. See *Advanced Features Menu*, page 52.
2. Press **Up** arrow several times to go to the *Information* menu.
3. Press and hold **Right** arrow/Reset for five seconds, then press **Enter/Ack** when display flashes *rESEt*.
Note: If **Enter/Ack** is not pressed within three seconds, display returns to meter Run.
4. The meter loads the factory default settings, and goes through an initialization sequence (same as on power-up).

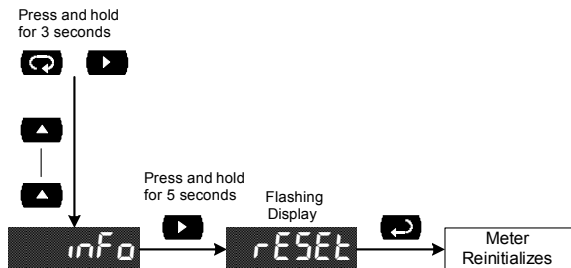

Factory Defaults & User Settings

The following table shows the factory setting for most of the programmable parameters on the meter. Next to the factory setting, the user may record the new setting for the particular application. Note that all settings are loaded with a default value, even though some settings may not be used. For example, the Slave mode is the default setting, but all of the Master mode settings have their default values loaded.

Model: _____ S/N: _____ Date: _____

Parameter	Display	Default Setting	User Setting
Mode	mModE	Master	
Function Code	FunCodeE	03	
Number of PVs	PUnbr	1	
Slave ID PV1	id-PU 1	247	
Register Number PV1	rEGPU 1	40001 (5 digit)	
Data Type	dRAr 1	Short integer (Binary & Signed)	
Byte Order	1234	Big-endian	
Polling Time	t-PoLL	2.0 second	
Slave Response Timeout	t-rESP	5.0 second	
Baud	bAud	2400	
Parity	PRr 4Y	Even	
Byte-to-byte timeout*	t-bytE	0.01 second	
Display decimal point	dddd.dd	2 places	
Input 1	mP 1	-199999	
Display 1	d 5 1	-1999.99	
Input 2	mP 2	999999	
Display 2	d 5 2	9999.99	

Parameter	Display	Default Setting	User Setting
Input 3	inP 3	300.00	
Display 3	d IS 3	300.00	
Input 4	inP 4	400.00	
Display 4	d IS 4	400.00	
Input 5	inP 5	500.00	
Display 5	d IS 5	500.00	
Input 6	inP 6	600.00	
Display 6	d IS 6	600.00	
Input 7	inP 7	700.00	
Display 7	d IS 7	700.00	
Input 8	inP 8	800.00	
Display 8	d IS 8	800.00	
Input 9	inP 9	900.00	
Display 9	d IS 9	900.00	
Input 10	inP 10	1000.00	
Display 10	d IS 10	1000.00	
Input 11	inP 11	1100.00	
Display 11	d IS 11	1100.00	
Input 12	inP 12	1200.00	
Display 12	d IS 12	1200.00	
Input 13	inP 13	1300.00	
Display 13	d IS 13	1300.00	
Input 14	inP 14	1400.00	
Display 14	d IS 14	1400.00	
Input 15	inP 15	1500.00	
Display 15	d IS 15	1500.00	
Input 16	inP 16	1600.00	

Parameter	Display	Default Setting	User Setting
Display 16	d 15 16	1600.00	
Relay 1 Action**	Act 1	Automatic	
Relay 1 Failsafe**	FLS 1	Off	
Relay 1 On-Delay**	on 1	0 seconds	
Relay 1 Off-Delay**	off 1	0 seconds	
Relay 1 Break Action**	brEAP 1	Relay goes on	
Relay 1 Set	SEt 1	70.00	
Relay 1 Reset	rSEt 1	60.00	
Relay 2 Set	SEt 2	100.00	
Relay 2 Reset	rSEt 2	90.00	
Relay 3 Set	SEt 3	130.00	
Relay 3 Reset	rSEt 3	120.00	
Relay 4 Set	SEt 4	160.00	
Relay 4 Reset	rSEt 4	150.00	
4-20 mA Scale: Display 1	d 15 1	0.00	
4-20 mA Scale: Output 1	out 1	4.000 mA	
4-20 mA Scale: Display 2	d 15 2	200.00	
4-20 mA Scale: Output 2	out 2	20.000 mA	
Password	PRSS	0000 (unlocked)	

Advanced Features		
Display Function	FuNC	Linear
Number of Points	no PtS	2
Filter	FILtEr	0
Bypass	bYPASS	0.2%
Cutoff	CutoFF	0.00 (disabled)
4-20 mA: Data Source	SourCE	Display value
4-20 mA: Overrange	O-rAnG	21.000 mA
4-20 mA: Underrange	U-rAnG	3.000 mA
4-20 mA: Comm. Break	brEAK	21.000 mA
4-20 mA: Maximum	mAX	23.000 mA
4-20 mA: Minimum***	mIn	0.000 mA
Display intensity	intY	Level 6

Notes:

* The byte-to-byte timeout setting might be updated automatically depending on the baud rate selected and the previous timeout setting. The minimum timeout allowed is saved to memory if a lower value is entered (e.g. If user enters 0.00 with a baud rate of 300, 0.06 is saved).

** These defaults are the same for all four relays.

*** The guaranteed minimum output for the 4-20 mA is 1.000 mA. Lower values may be possible, but are not guaranteed.

Troubleshooting Tips

Symptom	Check/Action
No display at all.	Check power at power connector. Check fuses (not supplied).
Not able to change setup or programming, $L\alpha C d$ is displayed.	Meter is locked, enter correct four-digit password to unlock.
Meter displays error message during scaling (<i>Error</i>).	Check input points for similar values.
Master displays a different value than PD865 display.	Check master data type setting. Make sure it matches the PD865 data type found in the Register Table.
PD865 Master displays a different value than slave device.	Check PD865 data type setting. Make sure it matches the slave data type.
PD865 Snooper mode going into communication break	Increase baud rate and/or poll time.
Display alternates between: 1. $H \cdot$ and a number 2. $L\alpha$ and a number	Press Menu to exit Max/Min display readings.
Display flashes - 99999 .	The data is less than the Input 1 value. Use a lower value for Input 1.
Display flashes 999999 .	The data is greater than the last Input point value. Use a higher value for the last Input point.
Display response is too slow.	Check filter and bypass values.
Relay operation is reversed.	Check: 1. Fail-safe in <i>Setup</i> menu. 2. Wiring of relay contacts.
Relay and status LED do not respond to signal.	Check: 1. Relay action in <i>Setup</i> menu. 2. Set and reset points.
Meter is not communicating.	Check: 1. Serial cabling (swapped lines). 2. Slave ID, parity, and baud rate.
Meter display occasionally jumps to another value.	Check that the polling time is not too fast for the chosen baud rate. For example, a polling time of 0.1 seconds is too fast for 2400 baud.
The display locks up or the meter does not respond at all.	Cycle the power to reboot the microprocessor.
Other symptoms not described above	Call Technical Support for assistance.

SLAVE MODE REGISTER TABLE

- 40001 – 40008: Process Value (PV), Max PV, Min PV, relay status, reset max & min Display value, Alarm & Relay status, Relay acknowledgement.
- 40009 – 40027: Initialize meter, Lock, Mode, Data Type, Display Decimal point, Linear/Square Root/Exponent, Exponent value, Serial settings, Unit address, byte-to-byte timeout, Number of scaling points, Slave Response timeout, Poll Time, Brightness, Bypass, Cutoff, Filter, Float decimal point.
- 40101 – 40128: Relays; Set & Reset points, Operating Mode, Turn-on & Turn-off delays.
- 40301 – 40317: 4-20mA output; Mode, Over-range value, Under-range value, Maximum allowed, Minimum allowed, Communications Break value, Display Value 1, Display Value 2, Output 1, Output 2, Data (mA/bits), and gain & offset calibration factors.
- 40401 – 40464: Input and Display values for 2 – 16 point scaling.
- 49101 – 49116: Product ID, Firmware Version, and Manufacturing Serial Number.
- 49201 – 49215: Reserved for user data.

Register Number	Register ¹ Address (hex)	Name	Access	Limits or Range ²	Data Type ³	Function Code(s)	Comments
40003 – 40004	2 – 3 (0002– 0003)	Maximum Display value	Read Write	-199999 to +999999	Long	03, 04, 16	Represents the Maximum display value, excluding the decimal point, since last power up or Max. Value reset. Decimal point setting in 40013. Writing any value will reset the max to the present display value.

PD865 Snooper Modbus Serial Input Meter

Instruction Manual: Register Table

Register ¹		Name	Access	Limits or Range ²	Data Type ³	Function Code(s)	Comments																				
Number	Address (hex)																										
40005 – 40006	4 – 5 (0004–0005)	Minimum Display value	Read Write	-199999 to +999999	Long	03, 04, 16	Represents the Minimum display value, excluding the decimal point, since last power up or Min. Value reset. Decimal point setting in 40013. Can be written to any value between -199999 to +999999. Writing any value will reset the max to the present display value.																				
40007	6 (0006)	Alarm and Relay Status	Read both, Write Relays	1 = In Alarm 1 = relay energized	Bits	03, 04, 06	Read alarm status and energized/non-energized status of relays. Alarms are read only; the upper byte is ignored for writes. Writing to a relay is only possible when the relay is in the Disabled mode. Alm = Alarm. Rly = Relay.																				
							<table border="1"> <tr> <td>15-12</td> <td>11</td> <td>10</td> <td>9</td> <td>8</td> <td>7-4</td> <td>3</td> <td>2</td> <td>1</td> <td>0</td> </tr> <tr> <td>0000</td> <td>Alm</td> <td>Alm</td> <td>Alm</td> <td>Alm</td> <td>0000</td> <td>Rly</td> <td>Rly</td> <td>Rly</td> <td>Rly</td> </tr> </table>	15-12	11	10	9	8	7-4	3	2	1	0	0000	Alm	Alm	Alm	Alm	0000	Rly	Rly	Rly	Rly
15-12	11	10	9	8	7-4	3	2	1	0																		
0000	Alm	Alm	Alm	Alm	0000	Rly	Rly	Rly	Rly																		
40008	7 (0007)	Alarm acknowledged	Write Only	0x0000 to 0x0F00	Bits	06	Clear Relay n alarm condition. Set bit equal to 1 to acknowledge. Only has effect on relays programmed to allow manual acknowledging. Alm = Alarm.																				
							<table border="1"> <tr> <td>15-12</td> <td>11</td> <td>10</td> <td>9</td> <td>8</td> <td>7-4</td> <td>3-0</td> </tr> <tr> <td>0000</td> <td>Alm</td> <td>Alm</td> <td>Alm</td> <td>Alm</td> <td>0000</td> <td>0000</td> </tr> </table>	15-12	11	10	9	8	7-4	3-0	0000	Alm	Alm	Alm	Alm	0000	0000						
15-12	11	10	9	8	7-4	3-0																					
0000	Alm	Alm	Alm	Alm	0000	0000																					
40009	8 (0008)	Initialize meter	Write Only	0xFF00 to initialize.	Integer	06	Write 0xFF00 to reinitialize the meter. Writing any other data has no effect.																				

PD865 Snooper Modbus Serial Input Meter

Instruction Manual: Register Table

Register Number	Register ¹		Name	Access	Limits or Range ²	Data Type ³	Function Code(s)	Comments
	Address (hex)							
40010	9 (0009)		Lock	Read Write	0x0000 to 0x9999	Integer (Packed BCD)	03, 04, 06, 16	See note 4.
40011	10 (000A)		Mode selection	Read Write	Not applicable	Word; bit flags	03, 04, 06, 16	This register can be read or written in Slave mode only. The mode can be changed from Slave to Master or Snooper. See Table 6.
40012	11 (000B)		Data Type	Read Write	Not applicable	Word; bit flags	03, 04, 06, 16	This Register is reserved for future use. Reading returns 0xffff and writing to it has no effect.
40013	12 (000C)		Display Decimal Point	Read Write	0 to 5	Integer	03, 04, 06, 16	See Bit Assignment Table 1.
40014	13 (000D)		Transfer Function	Read Write	0 to 2	Integer	03, 04, 06, 16	See Bit Assignment Table 2. Selecting Square Root or Exponent forces Register 40015 (number of points) to be 2.
40015	14 (000E)		Number of Points	Read Write	2 to 16	Integer	03, 04, 06, 16	Number of scaling points. This cannot be changed if the Transfer Function is set to Square Root or Exponent.
40016 – 40017	15 – 16 (000F – 0010)		Exponent	Read Write	0.5 to 2.99999	Long	03, 04, 16	If Square Root is selected, this value is ignored.
40018	17 (0011)		Byte-to- byte timeout	Read Write	0 to 2.54	Integer	03, 04, 06, 16	This is the timeout between bytes of a Modbus frame. It is automatically changed to 1.5 * character time when the baud rate is changed.

PD865 Snooper Modbus Serial Input Meter

Instruction Manual: Register Table

Register Number	Register ¹		Limits or Range ²	Access	Name	Data Type ³	Function Code(s)	Comments
	Address (hex)							
40019	18 (0012)		0 to 255	Read Write	Slave Response Timeout	Integer	03, 04, 06, 16	Corresponds to 0.0 to 25.5 seconds X3. Used in Slave mode as the waiting time for new PV data.
40020	19 (0013)		1 to 255	Read Write	Poll Time	Integer	03, 04, 06, 16	Corresponds to 0.1 to 25.5 seconds. 0 is not allowed. Polling time has to be greater than or equal to slave response time. Master mode only.
40021	20 (0014)		1 to 8	Read Write	LED brightness	Integer	03, 04, 06, 16	8 is the brightest level.
40022	21 (0015)		2 to 999	Read Write	Bypass	Integer	03, 04, 06, 16	Corresponds to 0.2 to 99.9%. If the input steps greater than the bypass value, it will be displayed immediately, with no filtering occurring. The number represents percent of full-scale. No effect if filter = 0.
40023	22 (0016)		0, 2 to 199	Read Write	Filter	Integer	03, 04, 06, 16	Display filtering. 0 = no filtering. New = old + ((new - old)/Filter)
40024 – 40025	23 – 24 (0017 – 0018)		0 to 999999	Read Write	Cutoff	Long	03, 04, 16	Represents the display value without the decimal point. A value of 000000 disables the cutoff.
40026	25 (0019)		Not applicable	Read Write	Serial Settings	Integer: bits	03, 04, 06, 16	See Bit Assignment Table 3.
40027	26 (001A)		1 to 247	Read Write	Unit Address	Integer	03, 04, 06, 16	Master mode: the address of the slave being read. Slave mode: the PD865 address.

Register ¹		Name	Access	Limits or Range ²	Data Type ³	Function Code(s)	Comments
Number	Address (hex)						
40028	27 (007B)	Float Decimal Point	Read Write	0 to 5	Integer	03, 04, 06, 16	See Bit Assignment Table 1 for operating modes and bit assignments.
40101 To 40107	100 – 101 (0064 – 0065) 102 – 103 (0066 – 0067) 104 (0068) 105 (0069) 106 (006A)	Set-point Reset-point Turn-on delay Turn-off delay Mode Comm. Break	Read Write	-199999 to 999999 (Set & Reset) 0 to 199 0 to 199 Bits 4, 2, 1, 0 Bits 6, 5	Long Long Integer Integer Word: bits	03, 04, 16 ----- 03, 04, 06, 16	Relay 1 parameters. Set and reset points represent the display value without the decimal point. See Bit Assignment Table 4 for operating modes and bit assignments.
40108 To 40114	107 – 108 (006B – 006C) 109 – 110 (006D – 006E) 111 (006F) 112 (0070) 113 (0071)	Set-point Reset-point Turn-on delay Turn-off delay Mode Comm. Break	Read Write	-199999 to 999999 (Set & Reset) 0 to 199 0 to 199 Bits 4, 2, 1, 0 Bits 6, 5	Long Long Integer Integer Word: bits	03, 04, 16 ----- 03, 04, 06, 16	Relay 2 parameters. Set and reset points represent the display value without the decimal point. See Bit Assignment Table 4 for operating modes and bit assignments.

PD865 Snooper Modbus Serial Input Meter

Instruction Manual: Register Table

Register Number	Register ¹		Limits or Range ²	Access	Name	Data Type ³	Function Code(s)	Comments
	Address (hex)							
40115 To 40121	114 – 115 (0072 – 0073)	Set-point Reset-point	-199999 to 999999 (Set & Reset)			Long Long	03, 04, 16 -----	Relay 3 parameters. Set and reset points represent the display value without the decimal point.
	116 – 117 (0074 – 0075)	Turn-on delay Turn-off delay Mode	0 to 199 0 to 199 Bits 4, 2, 1, 0	Read Write		Integer Integer Word: bits	03, 04, 06, 16	See Bit Assignment Table 4 for operating modes and bit assignments.
	118 (0076)	Comm. Break	Bits 6, 5					
	119 (0077) 120 (0078)							
40122 To 40128	121 – 122 (0079 – 007A)	Set-point Reset-point	-199999 to 999999 (Set & Reset)			Long Long	03, 04, 16 -----	Relay 4 parameters. Set and reset points represent the display value without the decimal point.
	123 – 124 (007B – 007C)	Turn-on delay Turn-off delay Mode	0 to 199 0 to 199 Bits 4, 2, 1, 0	Read Write		Integer Integer Word: bits	03, 04, 06, 16	See Bit Assignment Table 4 for operating modes and bit assignments.
	125 (007D)	Comm. Break	Bits 6, 5					
	126 (007E) 127 (007F)							
40301	300 (012C)	4-20mA out - Mode	Not applicable	Read Write		Integer: bits	03, 04, 06, 16	Selects output option and where the data source for the 4-20mA output. See Bit Assignment Table 5.

PD865 Snooper Modbus Serial Input Meter
Instruction Manual: Register Table

Register Number	Register ¹		Name	Access	Limits or Range ²	Data Type ³	Function Code(s)	Comments
	Address (hex)							
40302	301 (012D)		4-20mA out – Overrange value	Read Write	0 to 23999	Integer	03, 04, 06, 16	Corresponds to 0.000 to 23.999 mA. Because of hardware variations, the actual output range is designed to be at least 1.000 to 23.000 mA.
40303	302 (012E)		4-20mA out – Underrange value	Read Write	0 to 23999	Integer	03, 04, 06, 16	Corresponds to 0.000 to 23.999 mA. Because of hardware variations, the actual output range is designed to be at least 1.000 to 23.000 mA.
40304	303 (012F)		4-20mA out – Maximum value allowed	Read Write	0 to 23999	Integer	03, 04, 06, 16	Corresponds to 0.000 to 23.999 mA. Because of hardware variations, the actual output range is designed to be at least 1.000 to 23.000 mA.
40305	304 (0130)		4-20mA out – Minimum value allowed	Read Write	0 to 23999	Integer	03, 04, 06, 16	Corresponds to 0.000 to 23.999 mA. Because of hardware variations, the actual output range is designed to be at least 1.000 to 23.000 mA.
40306	305 (0131)		4-20mA out – Comm. Break value	Read Write	0 to 23999	Integer	03, 04, 06, 16	Corresponds to 0.000 to 23.999 mA. Because of hardware variations, the actual output range is designed to be at least 1.000 to 23.000 mA.
40307 – 40308	306 – 307 (0132 – 0133)		4-20mA out – Display Value ¹	Read Write	-199999 to +999999	Long	03, 04, 16	4-20mA output scaling. Represents the display value without the decimal point.

PD865 Snooper Modbus Serial Input Meter

Instruction Manual: Register Table

Register Number	Register ¹		Name	Access	Limits or Range ²	Data Type ³	Function Code(s)	Comments
	Address (hex)							
40309 – 40310	308 – 309 (0134 – 0135)		4-20mA out – Display Value 2	Read Write	-199999 to +999999	Long	03, 04, 16	4-20mA output scaling. Represents the display value without the decimal point.
40311	310 (0136)		4-20mA out – Output 1	Read Write	0 to 23999	Integer	03, 04, 06, 16	4-20mA output scaling. mA output at Display Value 1. Corresponds to 0.000 to 23.999 mA.
40312	311 (0137)		4-20mA out – Output 2	Read Write	0 to 23999	Integer	03, 04, 06, 16	4-20mA output scaling. mA output at Display Value 2. Corresponds to 0.000 to 23.999 mA.
40313	312 (0138)		4-20mA out – Data in mA or Data in bits	Read Write	0 to 23999 or 0 to 65535	Integer	03, 04, 06, 16	If 4-20mA output mode is set to “Serial Comm., mA” (0x83) this register is in μ A. Due to hardware variations, the actual output range is at least 1.000 to 23.000 mA. If 4-20mA output mode is set to “Serial Comm., bits” (0x84), this register is in DAC bits. See Bit Assignment Table 5.
40314 – 40315	313 – 314 (0139 – 013A)		4-20mA out – DAC calibration: Gain	Read Write	Dependent on hardware. Ideal = 2.85.	Float	03, 04, 16	4-20mA output gain calibration factor to convert mA to DAC counts.

PD865 Snooper Modbus Serial Input Meter
Instruction Manual: Register Table

Register Number	Register ¹		Limits or Range ²	Access	Name	Data Type ³	Function Code(s)	Comments
	Address (hex)							
40316 – 40317	315 – 316 (013B – 013C)		Dependent on hardware. Ideal = 0.	Read Write	4-20mA out – DAC calibration: Offset	Float	03, 04, 16	4-20mA output offset calibration factor to convert mA to DAC counts.
40401 – 40402 to 40431 – 40432	400 – 401 (0190 – 0191) to 430 – 431 (01AE – 01AF)		-199999 to 999999	Read Write	Input 1 to Input 16	Long	03, 04, 16	Input values for the scaling of 2 to 16 data points. Number of points set in Register 40015.
40433 – 40434 to 40463 – 40464	432 – 433 (01B0 – 01B1) to 462 – 463 (01CE – 01CF)		-199999 to 999999	Read Write	Display 1 to Display 16	Long	03, 04, 16	Display values for the scaling of 2 to 16 data points. Number of points set in Register 40015.
49101 To 49104	9100 – 9103 (238C – 238F)		Not applicable	Read Only	Product Identifier	ASCII characters	03, 04	8 characters indicating the product firmware number

PD865 Snooper Modbus Serial Input Meter
Instruction Manual: Register Table

Register Number	Register ¹		Name	Access	Limits or Range ²	Data Type ³	Function Code(s)	Comments
	Address (hex)							
49105 To 49108	9104 – 9107 (2390 – 2393)		Firmware Version	Read Only	Not applicable	ASCII characters	03, 04	8 characters indicating the firmware version number
49109 To 49116	9108 – 9115 (2394 – 239B)		Mfg. Serial Number	Read Only	Not applicable	ASCII characters	03, 04	16 (max) characters indicating the manufacturing serial number information.
49201 to 49216	9200 – 9215 (23F0 – 23FF)		User Data	Read Write	User Defined	Integer, Long or Word: bits	03, 04, 06, 16	This block of registers is reserved for user data.

Register Table Notes

Note 1. Although there are no specific 3x registers listed, all 4x Registers are mirrored into 3x register space, and are therefore capable of being read by Modbus function 04 (Read Input Registers). Register addresses in Modbus messages are referenced to zero (0), while Register numbers are referenced to one (1). For example, Register number 40100 is sent in the Modbus message as 0x0063 (100-1 = 99 \equiv 63 hex). If two addresses are shown separated by a “-”, they form a register pair to make the parameter into a 4-byte (32 bit) value.

Note 2. **Limits or Range:** Writing a value that is outside the parameters range will force it to be limited to the closest value within the range. For example; if the range is -1.99 to +1.99 and the value sent is 3.21, the value used is 1.99, or if -4.00 is sent, the value used will be -1.99. Exceptions are noted in the comments.

Note 3. **Data Types:**

Data format is highest byte first.

Word = 16 bit

Integer = -32768 to 32767

Long = -2,147,483,648 to 2,147,483,647

Float = IEEE floating point format, 4 bytes

”Display decimal point setting in 40013.” These values represent the number without regard to the decimal point. The decimal point setting can be found in Holding Register 40013. For example, if the number 12.34 is displayed, a read of 40001-40002 will return 1234 (0x000004D2). Register 40013 will contain 2 (0x0002) to indicate a decimal point setting of two places to the right of the decimal point.

Examples using integer and long (register values are shown in hexadecimal):

Displayed Process Value	Register 40001 - 40002	Register 40013
1.234	0000 04D2	0003
12.34	0000 04D2	0002
123.4	0000 04D2	0001
-123.4	FFFF FB2E	0001

Float decimal point setting is found in Holding Register 40028.

Examples using Float (register values are shown in hexadecimal):

Displayed Process Value	Register 40001 - 40002	Register 40013
1.234	3F9D F3B6	0003
12.34	4145 70A4	0002
123.4	42F6 CCCD	0001
-123.4	C2F6 CCCD	0001

Note 4. A read of the Lock register will return 0x0000 if the meter is unlocked, otherwise it will return 0xFFFF to indicate a locked meter. To unlock, the correct lock number must be written, which will then clear the lock number to 0x0000. If the wrong lock number is written, the reply will return 0xFFFF. If the correct lock number is written, the reply will be 0x0000. An unlocked meter can be locked by writing any non-zero value (from 1 to 9999).

Note 5. For the complete floating point standard, see IEEE 754-1985 *Standard for Binary Floating-Point Arithmetic*.

Register Bit Assignment Tables

Table 1. Display Decimal Point and Float Decimal Point

Bit(s)	15 – 3	2 – 0
Description	0 – 0	Decimal
		0 = dddddd 1 = dddd.d 2 = dddd.dd 3 = ddd.ddd 4 = dd.dddd 5 = d.ddddd 6 = dddddd 7 = dddddd

Table 2. Transfer Function

The exponent is programmable from 0.5 to 2.99999.

Bit(s)	15 – 2	1 – 0
Description	0 – 0	Transfer Function
		00 = Linear 01 = Square Root 10 = Exponent

Table 3. Serial Settings

Note that the Bus Type is not implemented in either hardware or firmware in this version.

Bit(s)	15 – 8	7	6	5 – 4	3	2 – 0
Description	0 – 0	Bus Type	0	Parity	0	Baud
		0 = RS232 or RS422 1 = RS485		0 = None 1 = Odd 2 = Even 3 = Even		0 = 300 1 = 600 2 = 1200 3 = 2400 4 = 4800 5 = 9600 6 = 19200 7 = 9600

Table 4. Relay Configuration (40107, 114, 121, 128)

When a relay has been disabled, it can be directly controlled using Register 40007.

Bit(s)	15 – 7	6 – 5	4	3	2 – 0
Description	0 – 0	Comm. Break	Fail-safe	0	Mode
		0 = No Action 1 = On 2 = Off	0 = Normal 1 = Fail-safe		0 = Auto 1 = Auto/Manual 2 = Manual 3 = Manual with Reset 4 = Alternating Pump 5 = Unused 6 = Unused 7 = Disabled (off)

Table 5. 4-20mA Output Modes

For the Serial Communications sources: Register 40313 holds the data, either as μA (0 to 23999 \equiv 0.000 to 23.999 mA) or DAC bits (0 to 65535). The DAC (Digital to Analog Converter) used for the 4-20 mA generation is updated whenever data is written to Register 40313.

For any of the Display value sources: The DAC is updated when the Display value is updated.

The actual 4-20 mA range is limited due to component tolerances, but is guaranteed by design to be at least from 1.000 to 23.000 mA.

Bit(s)	15 – 3	2 – 0
Description	0 – 0	4-20 mA Data Source
		0 = Display value 1 = Max Display value 2 = Min Display value 3 = Serial Communications: mA. 4 = Serial Communications: bits. 5 to 7 = Unused.

Table 6. Mode Selection (40011)

Bit(s)	7	6 – 4	3	2	1 – 0
Description	5 or 6 Digit Register	0 – 0	Function Code	0	Mode
	0 = 5 digit (x0001 x9999) 1 = 6 digit (x00001 x65536)		0 = 03 1 = 04 (Master/Snooper)		0 = Master 1 = Slave 2 = Snooper 3 = Defaults to Master

How to Contact Precision Digital

- For Technical Support:
Call: (800) 610-5239 or (508) 655-7300
Fax: (508) 655-8990
Email: support@predig.com
- For Sales Support or to place an order:
Call: (800) 343-1001 or (508) 655-7300
Fax: (508) 655-8990
Email: sales@predig.com
- For the latest version of this manual please visit:
www.predig.com

Order from:

C A Briggs Company

622 Mary Street; Suite 101

Warminster, PA 18974

Phone: 267-673-8117 - Fax: 267-673-8118

Sales@cabriggs.com - www.cabriggs.com

**PRECISION
DIGITAL** 