

# ProtEX-MAX PD8-6100 Explosion-Proof Strain Gauge, Load Cell & mV Meter Instruction Manual



Strain Gauge

- 15, 30, 150, 300 mV Unipolar Input Ranges
- $\pm 15$ ,  $\pm 25$ ,  $\pm 150$ ,  $\pm 250$  mV Bipolar Input Ranges
- Capture or Programmable Tare Feature
- Auto-Zero Feature Eliminates Zero Drift
- Ratiometric Operation
- Max/Min or Peak/Valley Hold Feature
- Display One Input in Two Different Scales (e.g. Weight & Volume)
- Rounding Function 1, 2, 5, 10, 20, 50, or 100
- Dual-Line Display
- Selectable 5 or 10 VDC Sensor Excitation
- Modern, Sleek and Practical Enclosure
- Display Mountable at 0°, 90°, 180°, & 270° Degrees
- Explosion-Proof, IP68, NEMA 4X Enclosure
- Input Power Options Include 85-265 VAC or 12-24 VDC
- SafeTouch® Through-Glass Button Programming
- Flanges for Wall or Pipe Mounting
- Superluminous Sunlight Readable Display
- Free USB Programming Software & Cable

Order from: **C A Briggs Company**  
622 Mary Street; Suite 101; Warminster, PA 18974  
Phone: 267-673-8117 - Fax: 267-673-8118  
[Sales@cabriggs.com](mailto:Sales@cabriggs.com) - [www.cabriggs.com](http://www.cabriggs.com)

**PRECISION  
DIGITAL** ÷

[www.predig.com](http://www.predig.com)

## Disclaimer

The information contained in this document is subject to change without notice. Precision Digital makes no representations or warranties with respect to the contents hereof and specifically disclaims any implied warranties of merchantability or fitness for a particular purpose.



**CAUTION:** *Read complete instructions prior to installation and operation of the meter.*



**WARNING:** *Risk of electric shock or personal injury.*



**Warning!**

- ***This product is not recommended for life support applications or applications where malfunctioning could result in personal injury or property loss. Anyone using this product for such applications does so at his/her own risk. Precision Digital Corporation shall not be held liable for damages resulting from such improper use.***
- ***Failure to follow installation guidelines could result in death or serious injury. Make sure only qualified personnel perform the installation.***
- ***Never remove the instrument cover in explosive environments when the circuit is live.***
- ***Cover must be fully engaged to meet flameproof/explosion-proof requirements.***
- ***Information in this manual supersedes all enclosure, compliance, and agency approval information included in additional product manuals included with this product.***

## Limited Warranty

Precision Digital Corporation warrants this product against defects in material or workmanship for the specified period under “Specifications” from the date of shipment from the factory. Precision Digital’s liability under this limited warranty shall not exceed the purchase value, repair, or replacement of the defective unit.

## Registered Trademarks

MeterView® Pro is a registered trademark of Precision Digital Corporation. Modbus® is a Registered Trademark of Schneider Automation Inc. All other trademarks mentioned in this document are the property of their respective owners.

© 2018 Precision Digital Corporation. All rights reserved.

**[www.predig.com](http://www.predig.com)**

# Table of Contents

<b>Table of Contents</b> .....	<b>3</b>	<i>Programming Set and Reset Points</i> .....	<b>39</b>
<b>Table of Figures</b> .....	<b>4</b>	<i>Setting Fail-Safe Operation</i> .....	<b>39</b>
<b>Introduction</b> .....	<b>4</b>	<i>Programming Time Delay</i> .....	<b>39</b>
<b>Ordering Information</b> .....	<b>5</b>	Relay and Alarm Operation Diagrams .....	<b>39</b>
<b>Specifications</b> .....	<b>6</b>	<i>High Alarm Operation (Set &gt; Reset)</i> .....	<b>39</b>
General .....	6	<i>Low Alarm Operation (Set &lt; Reset)</i> .....	<b>39</b>
Strain Gauge Input .....	7	<i>High Alarm with Fail-Safe Operation (Set &gt; Reset)</i> .....	<b>40</b>
Relays .....	7	<i>Low Alarm with Fail-Safe Operation (Set &lt; Reset)</i> .....	<b>40</b>
Isolated 4-20 mA Transmitter Output .....	7	<i>Pump Alternation Control Operation</i> .....	<b>40</b>
Digital Inputs & Outputs .....	8	<i>Relay Sampling Operation</i> .....	<b>41</b>
Serial Communications .....	8	<i>Time Delay Operation</i> .....	<b>41</b>
MeterView Pro.....	8	Relay Operation Details .....	<b>42</b>
Product Ratings and Approvals;.....	9	Overview.....	42
<b>Compliance Information</b> .....	<b>10</b>	Relays Auto Initialization.....	42
Safety.....	10	Fail-Safe Operation.....	42
Electromagnetic Compatibility .....	10	Front Panel LEDs.....	42
<b>Safety Information</b> .....	<b>11</b>	Latching and Non-Latching Relay Operation .....	<b>43</b>
<b>Installation</b> .....	<b>11</b>	Non-Latching Relay ( <i>RLto</i> ) .....	<b>43</b>
Unpacking .....	11	Non-Latching Relay ( <i>RLnr Rn</i> ).....	<b>43</b>
Pre-Installed Conduit/Stopping Plug .....	12	Latching Relay ( <i>LRtoH</i> ).....	<b>43</b>
Mounting .....	12	Latching Relay ( <i>LR-LLR</i> ).....	<b>43</b>
Cover Jam Screw.....	12	Acknowledging Relays.....	<b>44</b>
Sensor Excitation Voltage Selection (EX+, EX-) .....	12	Pump Alternation Control Applications ( <i>RLLRn</i> ) .....	<b>44</b>
Connections .....	13	Setting Up the Interlock Relay (Force On) Feature .....	<b>46</b>
Required & Factory Wired Connection.....	13	Scaling the 4-20 mA Analog Output ( <i>RAut</i> ) .....	<b>46</b>
Connectors Labeling .....	14	Setting Up the Password ( <i>PR55</i> ) .....	<b>47</b>
Power Connections .....	14	Protecting or Locking the Meter .....	<b>47</b>
Signal Connections .....	15	Making Changes to a Password Protected Meter .....	<b>47</b>
Switch Configuration .....	15	Disabling Password Protection .....	<b>47</b>
Shunt Calibration.....	17	Reset Menu ( <i>rESEt</i> ) .....	<b>48</b>
Serial Communications Connections .....	18	Tare Menu ( <i>tRrE</i> ) .....	<b>48</b>
Using ProVu Serial Adapters .....	20	Tare Functionality ( <i>tRrE</i> ).....	<b>48</b>
Relay Connections.....	21	Control Menu ( <i>CoNtRl</i> ) .....	<b>48</b>
Switching Inductive Loads.....	21	Advanced Features Menu.....	<b>49</b>
4-20 mA Output Connections.....	22	Advanced Features Menu & Display Messages .....	<b>49</b>
Analog Output Power Supply .....	22	Noise Filter ( <i>FiltEr</i> ) .....	<b>50</b>
F4 Digital Input Connections .....	22	Noise Filter Bypass ( <i>bYPASS</i> ).....	<b>50</b>
Interlock Relay Feature .....	22	Rounding Feature ( <i>round</i> ).....	<b>50</b>
Digital I/O Connections .....	23	Modbus RTU Serial Communications ( <i>SEr RL</i> ).....	<b>51</b>
External Switch Contacts .....	23	Serial Communications Overview .....	<b>51</b>
<b>Setup and Programming</b> .....	<b>24</b>	Select Menu ( <i>SELEct</i> ).....	<b>53</b>
SafeTouch® Buttons.....	24	Signal Input Conditioning ( <i>FunctiOn</i> ).....	<b>53</b>
Front Buttons and Status LED Indicators .....	25	Auto-Zero ( <i>AutO 0</i> ).....	<b>53</b>
MeterView® Pro Software.....	26	Low Cutoff ( <i>LowOFF</i> ) .....	<b>54</b>
MeterView Pro Installation.....	26	Analog Output Programming ( <i>RAutPr</i> ) .....	<b>54</b>
Display Functions & Messages .....	27	Programmable Function Keys User Menu ( <i>u5Er</i> ) .....	<b>54</b>
Setting Numeric Values.....	29	Internal Source Calibration ( <i>ILRL</i> ) .....	<b>56</b>
Main Menu .....	29	Error Message ( <i>Error</i> ).....	<b>57</b>
Setting Up the Meter ( <i>SEtUP</i> ) .....	30	<b>Meter Operation</b> .....	<b>58</b>
Setting the Input Signal ( <i>inPut</i> ).....	31	Front Buttons Operation.....	58
Setting the Input Units ( <i>un it5</i> ).....	32	SafeTouch® Buttons.....	58
Setting the Input Units or Custom Tags ( <i>un it5</i> ) .....	33	Function Keys Operation .....	59
Programming the Meter ( <i>PrOG</i> ) .....	34	Maximum/Minimum Readings.....	59
Calibrating the Meter with Strain Gauge/Load Cell ( <i>LRl</i> ).....	34	<b>Troubleshooting</b> .....	<b>60</b>
Setting the Display Parameter & Intensity ( <i>d5PLAy</i> ) .....	36	Diagnostics Menu ( <i>d RL</i> ).....	60
Setting the Relay Operation ( <i>rELAY</i> ) .....	37	Determining Software Version .....	60
Setting the Relay Action.....	38	Reset Meter to Factory Defaults .....	60
		Factory Defaults & User Settings.....	61
		Troubleshooting Tips (Including FAULT & ERROR Messages).....	62

Service..... 63 EU Declaration of Conformity ..... 65  
 Mounting Dimensions..... 64

## Table of Figures

Figure 1. Sensor Excitation Voltage Selection ..... 12  
 Figure 2: Integrated ProVu Required Connections .. 13  
 Figure 3. Connector Labeling for Fully Loaded PD8-6100 ..... 14  
 Figure 4. Power Connections..... 14  
 Figure 5. Strain Gauge Configuration Switch..... 15  
 Figure 6. Strain Gauge Powered by Internal Supply 16  
 Figure 7. Strain Gauge Powered by External Supply 16  
 Figure 8. mV Transducer Input Connections..... 17  
 Figure 9. Shunt Resistor..... 17  
 Figure 10: ProtEX-MAX Connections to a Serial Converter ..... 18  
 Figure 11. Three-Wire RS485 Connection ..... 18  
 Figure 12: RS-485 Wiring..... 19  
 Figure 13: RS-485 Two-Wire Multi-Drop Wiring ..... 20  
 Figure 14. Relay Connections..... 21  
 Figure 15. AC and DC Loads Protection ..... 21  
 Figure 16. Low Voltage DC Loads Protection ..... 21  
 Figure 17. 4-20 mA Output Connections..... 22  
 Figure 18. F4 Digital Input Connections ..... 22  
 Figure 19. Interlock Connections ..... 22  
 Figure 20: Digital I/O Connections ..... 23  
 Figure 21. Acknowledge Relays with Digital Input.... 44  
 Figure 22: General Four-Wire Network Connection.. 52  
 Figure 23: General Two-Wire Network Connection... 52  
 Figure 24: Enclosure Dimensions – Front View ..... 64  
 Figure 25: Enclosure Dimensions – Side Cross Section View..... 64

## Introduction

The ProtEX-MAX PD8-6100 offers all the functionality of the ProVu PD6100 as a fully FM, CSA, ATEX, and IECEx approved explosion-proof product. It accepts strain gauge & load cell inputs and mV signals up to 300 mV (unipolar) and ± 250 mV (bipolar) for weight and force measurement applications. The PD8-6100 strain gauge meter’s dual-line display and powerful dual-scale capability allows the measurement to be displayed in two different units of measure. Another use for the PD8-6100’s dual-lines is to simply display the units of measure on the bottom line. SafeTouch® through-glass buttons allow for access to zero, tare, and other functions without the need to remove the enclosure cover.

## Ordering Information

### SunBright Display Models

85-265 VAC Model	12-24 VDC Model	Options Installed
PD8-6100-6H0	PD8-6100-7H0	No options
PD8-6100-6H7	PD8-6100-7H7	4 relays & 4-20 mA output



WARNING - Cancer and Reproductive Harm - [www.P65Warnings.ca.gov](http://www.P65Warnings.ca.gov)

### Accessories

Model	Description
PDA1232	RS-232 serial adapter
PDA1485	RS-485 serial adapter
PDA7485-I	RS-232 to RS-422/485 isolated converter
PDA8485-I	USB to RS-422/485 isolated converter
PDX6901	Suppressor (snubber): 0.01 $\mu$ F/470 $\Omega$ , 250 VAC

## Specifications

Except where noted all specifications apply to operation at +25°C.

### General

<b>Display</b>	Line 1: 0.60" (15 mm) high, red LEDs Line 2: 0.46" (12 mm) high, red LEDs 6 digits each (-99999 to 999999), with lead zero blanking
<b>Display Intensity</b>	Eight user selectable intensity levels
<b>Display Update Rate</b>	5/second (200 ms)
<b>Overrange</b>	Display flashes 999999
<b>Underrange</b>	Display flashes -99999
<b>Display Assignment</b>	The displays may be assigned to PV1, PV2, PCT, max & min, set points, PV & units, units (lower display only), net & gross weight, Modbus input, and display millivolts.
<b>Units</b>	lb, kg, ounce, gram, ton, metric ton (tonne), custom units.
<b>Programming Methods</b>	Four front panel buttons, digital inputs, PC and MeterView Pro software, or Modbus registers.
<b>Noise Filter</b>	Programmable from 2 to 199 (0 will disable filter)
<b>Filter Bypass</b>	Programmable from 0.1 to 99.9% of calibrated span
<b>Rounding</b>	Select 1, 2, 5, 10, 20, 50, or 100 (e.g. rounding = 10, value = 123.45, display = 123.50).
<b>Recalibration</b>	All ranges are calibrated at the factory. Recalibration is recommended at least every 12 months.
<b>Max/Min Display</b>	Max/min readings reached by the process are stored until reset by the user or until power to the meter is cycled.
<b>Password</b>	Three programmable passwords restrict modification of programmed settings. Pass 1: Allows use of function keys and digital inputs Pass 2: Allows use of function keys, digital inputs and editing set/reset points Pass 3: Restricts all programming, function keys, and digital inputs.
<b>Non-Volatile Memory</b>	All programmed settings are stored in non-volatile memory for a minimum of ten years if power is lost.
<b>Connections</b>	Screw terminals accept 12 to 22 AWG wire

<b>Fuse</b>	Required external fuse: UL Recognized, 5 A max, slow blow; up to 6 meters may share one 5 A fuse
<b>Normal Mode Rejection</b>	Greater than 60 dB at 50/60 Hz
<b>Isolation</b>	4 kV input-to-power line 500 V input-to-output (powered by external supply)
<b>Overvoltage Category</b>	Installation Overvoltage Category II: Local level with smaller transient overvoltages than Installation Overvoltage Category III.
<b>Environmental</b>	T6 Class operating temperature range Ta = -40 to 60°C T5 Class operating temperature range Ta = -40 to 65°C
<b>Max Power Dissipation</b>	Maximum power dissipation limited to 15.1 W.
<b>Enclosure</b>	Explosion-proof die cast aluminum with glass window, corrosion resistant epoxy coating, color: blue. NEMA 4X, 7, & 9, IP68. Default conduit connections: Four ¾" NPT threaded conduit openings and two ¼" NPT metal conduit plugs with 12 mm hex key fitting installed. Additional conduit opening configurations may be available; verify quantity and sizes on specific device labeling during installation.
<b>Mounting</b>	Four slotted flanges for wall mounting or NPS 1½" to 2½" or DN 40 to 65 mm pipe mounting. See Mounting Dimensions on page 64.
<b>Tightening Torque</b>	Screw terminal connectors: 5 lb-in (0.56 Nm)
<b>Overall Dimensions</b>	6.42" x 7.97" x 8.47" (W x H x D) (163 mm x 202 mm x 215 mm)
<b>Approximate Shipping Weight</b>	16.0 lbs (7.26 kg)
<b>Warranty</b>	3 years parts & labor



## Strain Gauge Input

<b>Inputs</b>	Field selectable: 0-15, 0-30, 0-150, 0-300 mV, $\pm 15$ , $\pm 25$ , $\pm 150$ , $\pm 250$ mV, or Modbus PV (Slave)	
<b>Accuracy</b>	$\pm 0.03\%$ of calibrated span $\pm 1$ count	
<b>Temperature Drift</b>	0.002% of calibrated span/ $^{\circ}\text{C}$ max from 0 to $65^{\circ}\text{C}$ ambient, 0.005% of calibrated span/ $^{\circ}\text{C}$ max from $-30$ to $0^{\circ}\text{C}$ ambient	
<b>Functions</b>	Linear with multi-point linearization	
<b>Multi-Point Linearization</b>	2 to 32 points for PV or PV1 2 to 8 points for PV2 (Dual-scale feature)	
<b>Low Cutoff</b>	0-999999 (0 disables cutoff function)	
<b>Decimal Point</b>	Up to five decimal places or none: ddddddd, ddddd, dddd, ddd, dd, or d	
<b>Calibration Range</b>	Input Range	Minimum Span Input 1 & Input 2
	15 mV	0.2 mV
	25 mV, 30 mV	0.4 mV
	150 mV	2.0 mV
	250 mV, 300 mV	4.0 mV
	An Error message will appear if the input 1 and input 2 signals are too close together.	
<b>Input Impedance</b>	Strain Gauge Bridge: Greater than 10 M $\Omega$ mV Source: 200 k $\Omega$	
<b>Isolated Excitation Power Supply</b>	Terminals Ex+ & Ex- may be used for sensor excitation, 10 VDC or 5 VDC $\pm 10\%$ @ 25 mA max. Field selectable for 10 VDC excitation voltage to operate up to two 1000 $\Omega$ strain gauges, or 5 VDC excitation voltage to operate up to four 1000 $\Omega$ strain gauges or one 350 $\Omega$ strain gauge. <i>For safe area only, not agency approved installations, Ex+ &amp; Ex- may be used for sensor excitation; 10 VDC or 5 VDC <math>\pm 10\%</math> @ 350 mA max.</i>	

## Relays

<b>Rating</b>	4 SPDT (Form C) internal and/or 4 SPST (Form A) external; rated 3 A @ 30 VDC and 125/250 VAC resistive load; 1/14 HP ( $\approx 50$ W) @ 125/250 VAC for inductive loads
<b>Noise Suppression</b>	Noise suppression is recommended for each relay contact switching inductive loads; see page 21 for details.


<b>Deadband</b>	0-100% of span, user programmable
<b>High or Low Alarm</b>	User may program any alarm for high or low trip point. Unused alarm LEDs and relays may be disabled (turn off).
<b>Relay Operation</b>	Automatic (non-latching) Latching (requires manual acknowledge) Sampling (based on time) Pump alternation control (2 to 4 relays) Off (disable unused relays and enable Interlock feature) Manual on/off control mode
<b>Relay Reset</b>	User selectable via front panel buttons or digital inputs <ol style="list-style-type: none"> <li>Automatic reset only (non-latching), when the input passes the reset point.</li> <li>Automatic + manual reset at any time (non-latching)</li> <li>Manual reset only, at any time (latching)</li> <li>Manual reset only after alarm condition has cleared (L)</li> </ol> <p><i>Note: Front panel button or digital input may be assigned to acknowledge relays programmed for manual reset.</i></p>
<b>Time Delay</b>	0 to 999.9 seconds, on & off relay time delays Programmable and independent for each relay
<b>Fail-Safe Operation</b>	Programmable and independent for each relay. <i>Note: Relay coil is energized in non-alarm condition. In case of power failure, relay will go to alarm state.</i>
<b>Auto Initialization</b>	When power is applied to the meter, relays will reflect the state of the input to the meter.

## Isolated 4-20 mA Transmitter Output

<b>Output Source</b>	Process variable (PV), max, min, set points 1-4, Modbus input, or manual control mode
<b>Scaling Range</b>	1.000 to 23.000 mA for any display range
<b>Calibration</b>	Factory calibrated: 0.00 to 100.00 = 4-20 mA output
<b>Analog Output Programming</b>	1.000 mA minimum and 23.000 mA maximum for all parameters: overrange, underrange, max, min, and break
<b>Accuracy</b>	$\pm 0.1\%$ of span $\pm 0.004$ mA

<b>Temperature Drift</b>	0.4 $\mu\text{A}/^\circ\text{C}$ max from 0 to 65 $^\circ\text{C}$ ambient, 0.8 $\mu\text{A}/^\circ\text{C}$ max from -40 to 0 $^\circ\text{C}$ ambient <i>Note: Analog output drift is separate from input drift.</i>		
<b>Non-Isolated Transmitter Power Supply</b>	Terminals I+ & R: 24 VDC $\pm$ 10% . May be used to power the 4-20 mA output or other devices (except load cell/strain gauge). Refer to Figure 3 on page 14 and Figure 17 on page 22. All models @ 25mA max.		
<b>External Loop Power Supply</b>	35 VDC maximum		
<b>Output Loop Resistance</b>	Power supply	Minimum	Maximum
	24 VDC	10 $\Omega$	700 $\Omega$
	35 VDC (external)	100 $\Omega$	1200 $\Omega$

### Digital Inputs & Outputs

<b>Channels</b>	4 digital inputs & 4 digital outputs
<b>Digital Input Logic High</b>	3 to 5 VDC
<b>Digital Input Logic Low</b>	0 to 1.25 VDC
<b>Digital Output Logic High</b>	3.1 to 3.3 VDC
<b>Digital Output Logic Low</b>	0 to 0.4 VDC
<b>Source Current</b>	10 mA maximum output current
<b>Sink Current</b>	1.5 mA minimum input current
<b>+5 V Terminal</b>	To be used as pull-up for digital inputs only. Connect normally open pushbuttons across +5 V & DI 1-4.  <b>DO NOT</b> use +5 V terminal (pin 1) to power external devices. <b>WARNING</b>
<b>Function Assignment</b>	The on-board digital inputs (1-4) are designed to mimic the behavior of the front panel buttons (Menu, F1, F2, & F3). If you wish to change their behavior, re-assign F1-F3 to the desired function, then change the corresponding digital input to match.

### Serial Communications

<b>Compatibility</b>	EIA-485
<b>Connectors</b>	Removable screw terminal connector
<b>Max Distance</b>	3,937' (1,200 m) max
<b>Status Indication</b>	Separate LEDs for Power (P), Transmit (TX), and Receive (RX)
<b>Slave ID</b>	1 – 247 (Meter address)
<b>Baud Rate</b>	300 – 19,200 bps
<b>Transmit Time Delay</b>	Programmable between 0 and 199 ms or transmitter always on for RS-422 communication
<b>Data</b>	8 bit (1 start bit, 1 or 2 stop bits)
<b>Parity</b>	Even, Odd, or None with 1 or 2 stop bits
<b>Byte-to-Byte Timeout</b>	0.01 – 2.54 second
<b>Turn Around Delay</b>	Less than 2 ms (fixed)

*Note: Refer to the PROVu<sup>®</sup> Modbus Register Tables located at [www.predig.com](http://www.predig.com) for details.*


### MeterView Pro

<b>System Requirements</b>	Microsoft <sup>®</sup> Windows <sup>®</sup> XP/Vista/7/8/10
<b>Communications</b>	USB 2.0 (Standard USB A to Micro USB B)
<b>Configuration</b>	Configure device settings one at a time



## Product Ratings and Approvals;

---

<b>FM</b>	Enclosure: Type 4X; IP66 Class I, Division 1, Groups B, C, D Class II, Division 1, Groups E, F, G Class III, Division 1, T5/T6 Class I, Zone 1, AEx d, IIC Gb T5/T6 Zone 21, AEx tb IIIC T90°C; Ta -40°C to +65°C T6 Ta = -40°C to +60°C; T5 Ta = -40°C to +65°C Certificate Number: 3047283
<b>CSA</b>	Class I, Division 1, Groups B, C, D Class II, Division 1, Groups E, F, G Class III, Division 1 Class I Zone 1 Ex d IIC Zone 21 Ex tb IIIC T90°C -40°C < Tamb. < +60° C; Temperature Code T6 -40°C < Tamb. < +65° C; Temperature Code T5 Enclosure Type 4X & IP66 Certificate Number: 2531731
<b>ATEX</b>	 II 2 G D Ex d IIC T* Gb Ex tb IIIC T90°C Db IP68 Ta = -40°C to +*°C *T6 = -40°C to +60°C *T5 = -40°C to +65°C Certificate number: Sira 12ATEX1182
<b>IECEX</b>	Ex d IIC T* Gb Ex tb IIIC T90°C Db IP68 Ta = -40°C to +*°C *T6 = -40°C to +60°C *T5 = -40°C to +65°C Certificate Number: IECEX SIR 12.0073

---

### **Special Conditions for Safe Use:**

Use suitably certified and dimensioned cable entry device and/or plug. The equipment shall be installed such that the supply cable is protected from mechanical damage. The cable shall not be subjected to tension or torque. If the cable is to be terminated within an explosive atmosphere, then appropriate protection of the free end of the cable shall be provided. Cable must be suitable for 90°C.

### **Year of Construction**

This information is contained within the serial number with the first four digits representing the year and month in the YYMM format.

**For European Community:** The ProtEX-MAX must be installed in accordance with the ATEX directive 94/9/EC, and the product certificate Sira 12ATEX1182.

## Compliance Information

### Safety

<b>UL &amp; c-UL Listed</b>	USA & Canada UL 508 Industrial Control Equipment
<b>UL File Number</b>	E160849
<b>Front Panel</b>	UL Type 4X, NEMA 4X, IP65; panel gasket provided
<b>Low Voltage Directive</b>	EN 61010-1:2010 Safety requirements for measurement, control, and laboratory use

### Electromagnetic Compatibility

<b>EMISSIONS</b>	EN 55022:2010 Class A ITE emissions requirements
Radiated Emissions	Class A
AC Mains Conducted Emissions	Class A
<b>IMMUNITY</b>	EN 61326-1:2013 Measurement, control, and laboratory equipment EN 61000-6-2:2005 EMC heavy industrial generic immunity standard
RFI - Amplitude Modulated	80 -1000 MHz 10 V/m 80% AM (1 kHz) 1.4 - 2.0 GHz 3 V/m 80% AM (1 kHz) 2.0 - 2.7 GHz 1 V/m 80% AM (1 kHz)
Electrical Fast Transients	±2kV AC mains, ±1kV other
Electrostatic Discharge	±4kV contact, ±8kV air
RFI - Conducted	10V, 0.15-80 MHz, 1kHz 80% AM
AC Surge	±2kV Common, ±1kV Differential
Surge	1KV (CM)
Power-Frequency Magnetic Field	30 A/m 70%V for 0.5 period
Voltage Dips	40%V for 5 & 50 periods 70%V for 25 periods
Voltage Interruptions	<5%V for 250 periods

**Note:**

*Testing was conducted on PD8-6100 meters installed through the covers of grounded metal enclosures with cable shields grounded at the point of entry representing installations designed to optimize EMC performance.*

*Declaration of Conformity available at [www.predig.com](http://www.predig.com)*

## Safety Information



### WARNINGS

- Read complete instructions prior to installation and operation of the instrument.
- Installation and service should be performed only by trained service personnel. Service requiring replacement of internal sub-components must be performed at the factory.
- Disconnect from supply before opening enclosure. Keep cover tight while circuits are alive. Conduit seals must be installed within 18" (450mm) of the enclosure or within 2" (50mm) for Zone installations.
- Verify that the operating atmosphere of the instrument is consistent with the appropriate hazardous locations certifications.
- If the instrument is installed in a high voltage environment and a fault or installation error occurs, high voltage may be present on any lead
- Read all product labels completely and follow all instructions and requirements listed on the labels for installation or service.

## Installation

*Install in accordance with applicable local and national regulations (e.g. NEC).*

**For Installation in USA:** The ProtEX-MAX must be installed in accordance with the National Electrical Code (NEC) NFPA 70.

**For Installation in Canada:** The ProtEX-MAX must be installed in accordance with the Canadian Electrical Code CSA 22.1. All power supplies below 36 V and input circuits must be derived from a CSA Approved Class 2 source.

**For European Community:** The ProtEX-MAX must be installed in accordance with the ATEX directive 94/9/EC and the product certificate Sira 12ATEX1182.



### WARNING

Disconnect from supply before opening enclosure. Keep cover tight while circuits are alive. Conduit seals must be installed within 18" (450mm) of the enclosure or within 2" (50mm) for Zone installations.

Wiring connectors are accessed by opening the enclosure. To access electrical connectors, remove the 2 captive screws and then remove the electronics module. Connectors are on the rear of the electronics module.


## Unpacking

Remove the instrument from packing box. Inspect the packaging and contents for damage. Report damages, if any, to the carrier.

If any part is missing or the instrument malfunctions, please contact your supplier or the factory for assistance.

## Pre-Installed Conduit/Stopping Plug


The PD8-6000 is supplied with two pre-installed conduit plugs for installations that do not require the use of all conduit entries. The conduit/stopping plugs include an internal 12mm hexagonal socket recess for removal. The pre-installed plugs and their installation are included in the hazardous area approvals for the PD8 Series enclosure.



**WARNING** In hazardous areas, conduit and conduit/stopping plugs require the application of non-setting (solvent free) thread sealant. It is critical that all relevant hazardous area guidelines be followed for the installation or replacement of conduit or plugs.

## Mounting

The ProtEX-MAX has four slotted mounting flanges that should be used for pipe mounting or wall mounting. Refer to *Mounting Dimensions*, page 64 for details.



**WARNING** Do not attempt to loosen or remove flange bolts while the instrument is in service.

## Cover Jam Screw

The cover jam screw should be properly installed once the instrument has been wired and tested in a safe environment. The cover jam screw is intended to prevent the removal of the instrument cover in a flameproof environment without the use of tools. Using a M2 hex wrench, turn the screw clockwise until the screw contacts the aluminum enclosure. Turn the screw an additional 1/4 to 1/2 turn to secure the cover. Caution: Excess torque may damage the threads and/or wrench.

## Sensor Excitation Voltage Selection (EX+, EX-)

All meters, including models equipped with the 12-24 VDC power option, are shipped from the factory configured to provide 10 VDC excitation for the sensor.

If the sensor requires 5 VDC excitation, the internal jumper J3 must be configured accordingly.

To access the voltage selection jumper:

1. Remove all the wiring connectors.
2. Unscrew the back cover.
3. Slide out the back cover by about 1 1/2 inches.
4. Configure the J3 jumper, located behind the input signal connector, for the desired excitation voltage as shown.

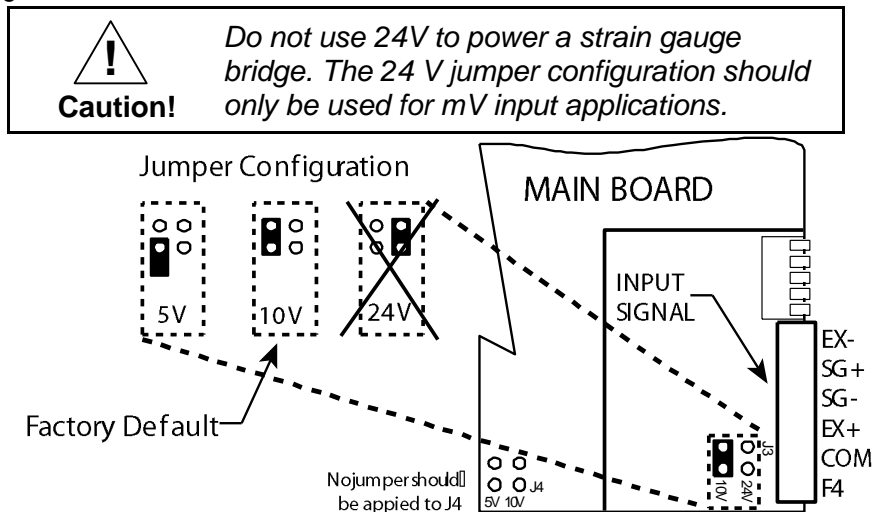



Figure 1. Sensor Excitation Voltage Selection

## Connections



**WARNINGS**

- **Static electricity can damage sensitive components.**
- **Observe safe handling precautions for static-sensitive components.**
- **Use proper grounding procedures/codes.**
- **If the instrument is installed in a high voltage environment and a fault or installation error occurs, high voltage may be present on any lead or terminal.**
- **Follow all fusing and wiring precautions requirements for the instrument integrated to the PD8 Series model number being connected.**

To access the connectors, remove the enclosure cover and unscrew the two captive screws that fasten the electronics module. Signal connections are made to de-pluggable connectors on the back of the electronics module.

Some connectors may be provided already connected. These connections are required for proper operation of the ProtEX-MAX, and should not be removed unless instructed to by this manual.


Wires marked as being used for testing purposes should be removed.

Grounding connections are made to the two ground screws provided on the base – one internal and one external.

After all connections have been completed and verified, apply power to the unit.

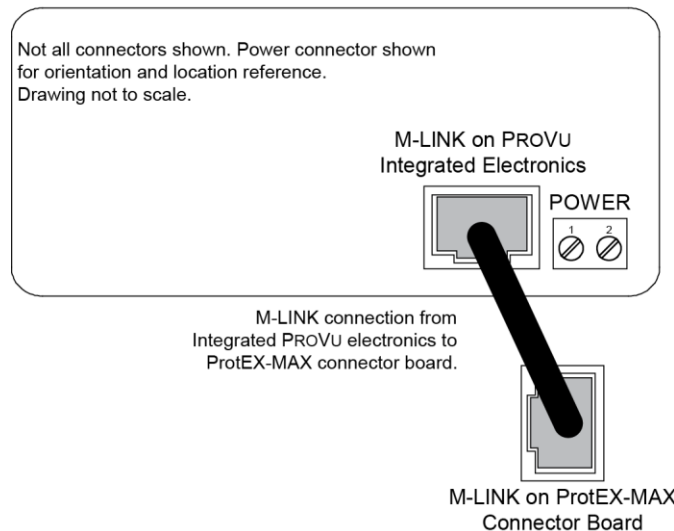
### Required & Factory Wired Connection

The ProtEX-MAX comes with a pre-wired connection. This connection is detailed below, and must be maintained in order for the instrument to function properly.



**WARNING**


Observe all safety regulations. Electrical wiring should be performed in accordance with all agency requirements and applicable national, state, and local codes to prevent damage to the meter and ensure personnel safety.



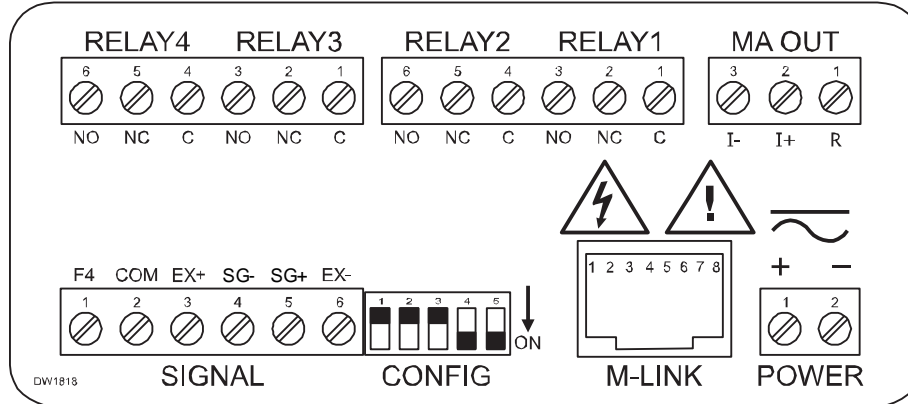
**Figure 2: Integrated ProVu Required Connections**

### Connectors Labeling

The connectors' label, affixed to the meter, shows the location of all connectors available with requested configuration.



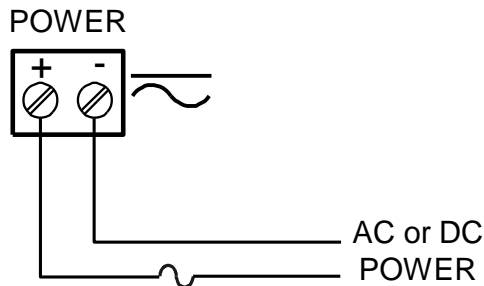
**Warning!** *Do not connect any equipment other than Precision Digital's expansion modules, cables, or meters to the RJ45 M-LINK connector. Otherwise damage will occur to the equipment and the meter.*



**Figure 3. Connector Labeling for Fully Loaded PD8-6100**

### Power Connections

Power connections are made to a two-terminal connector labeled POWER on Figure 3. The meter will operate regardless of DC polarity connection. The + and - symbols are only a suggested wiring convention.



Required External Fuse:  
5 A max, 250 V Slow Blow

**Figure 4. Power Connections**

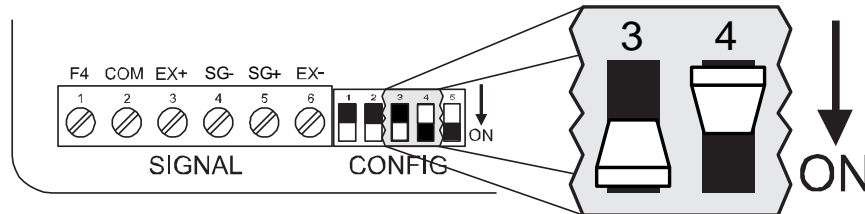


### Signal Connections

Signal connections are made to a six-terminal connector labeled SIGNAL on Figure 3. The EX- (negative excitation) terminal is used to sense the sensor excitation voltage for ratiometric operation, when the sensor is powered externally.

### Switch Configuration

Setup and programming is performed both through the front panel buttons and switch settings shown below. The switch configuration must correspond to the setup and programming starting on page 29 (same range, type, etc.).



**Figure 5. Strain Gauge Configuration Switch**

#### Excitation (Switch 1)

The excitation switch designates whether the meter will use its internal power supply or an external power supply.

Switch 1	ON	Excitation	<u>Internal</u> Excitation	When switch is turned ON, the ProVu's power supply is used.
	OFF	Excitation	<u>External</u> Excitation	When switch is turned OFF, an external power supply is used.

#### Range (Switch 2)

The range switch adjusts the gain of the internal circuitry. Narrower ranges require more amplification.

Switch 2	ON	Range	<u>Higher</u> internal gain	Turn this switch ON for the following input ranges: 15, 30, ±15, or ±25 mV.
	OFF	Range	<u>Lower</u> internal gain	Turn this switch OFF for the following input ranges: 150, 300, ±150, or ±250 mV.

#### Polarity (Switch 3)

The polarity switch selects whether the range is unipolar and starts at zero (i.e. 0 to 30 mV) or bipolar and starts at a negative value, or below zero (i.e. -15 to +15 mV).

Switch 3	ON	Polarity	Range <u>starts</u> at zero (unipolar)	Turn this switch ON for the following input ranges: 15, 30, 150, or 300.
	OFF	Polarity	Range <u>starts</u> below zero (bipolar)	Turn this switch OFF for the following input ranges: ±15, ±25, ±150, or ±250 mV.

#### Source (Switch 4)

The source switch tells the ProVu whether the input is a strain gauge bridge (i.e. Figure 11), or it is a signal from a 2 or 4 wire transducer, or mV source (i.e. Figure 12)

Switch 4	ON	Source	Source is mV input transducer	Turn this switch ON if the connected source is a transducer*
	OFF	Source	Source is strain gauge bridge	Turn this switch OFF if the source is a strain gauge bridge

\*Ratio should be set to NO in Setup Input Menu

### Shunt Resistor (Switch 5)

The PD8-6100 provides a means of simulating strain in a strain gauge bridge circuit via a 60.4KΩ shunt resistor included in the meter. This will simulate an approximate 70% full-scale load in the case of a 350Ω strain bridge.

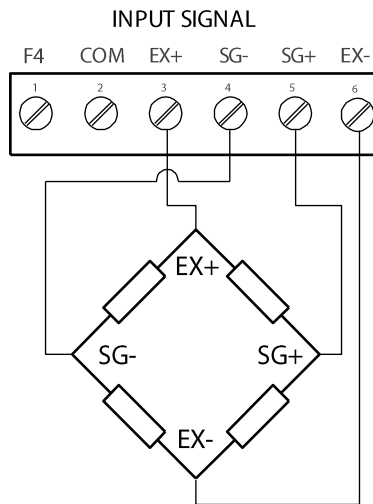
Switch 5	ON	Shunt	Shunt resistor is <u>connected</u> to the input bridge.	Turn switch ON when you want to simulate a strain load
	OFF	Shunt	Shunt resistor is <u>disconnected</u> from the input bridge.	Turn this switch OFF to remove the shunt resistor

### Strain Gauge Connections

The following figures show examples of strain gauge connections.

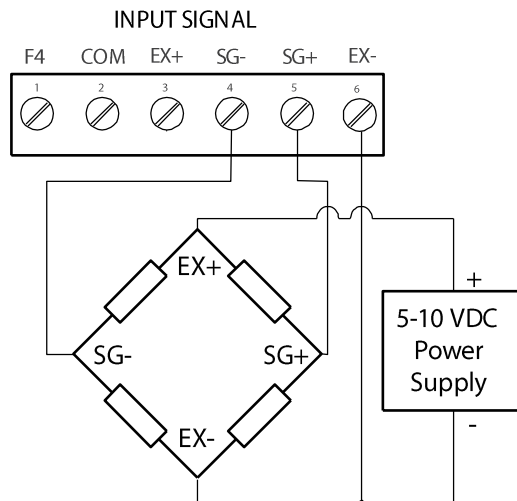
There is a 5-position DIP switch (CONFIG) to set up the input ranges and ratiometric operation.

**NOTE: Refer to Switch Configuration starting on page 15 for proper configuration switch positioning.**

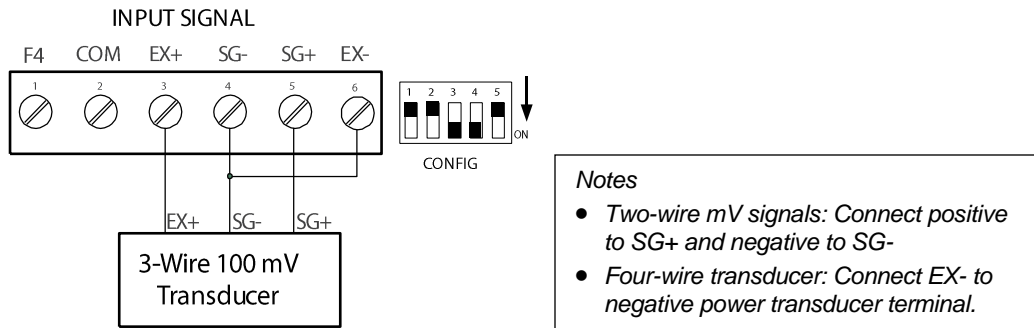


**Figure 6. Strain Gauge Powered by Internal Supply**

**NOTE: Refer to Switch Configuration starting on page 15 for proper switch positioning for the following wiring configurations.**



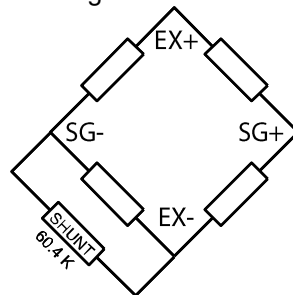
**Figure 7. Strain Gauge Powered by External Supply**



**Figure 8. mV Transducer Input Connections**

### Shunt Calibration

The PD8-6100 is equipped with a means of simulating strain in a strain gauge bridge circuit, via an included shunt resistor in the meter. This technique is performed by enabling the “shunt resistor” switch (switch 5), which in turn shunts one leg of a connected strain bridge with a predetermined resistive load (60.4k). This technique can be used as a means of verifying instrumentation by simulating a physical input. With no load connected, the enabling of the shunt resistor (switch 5) will simulate approximately a 70% F.S. load in the case of a 350Ω Strain Bridge.



**Figure 9. Shunt Resistor**

### Serial Communications Connections

The ProtEX-MAX has a 5 position terminal block for connecting RS-485 serial devices.

Figure 10 details the wiring connections from the ProtEX-MAX to an RS-485 serial converter (such as the PDA7485 or PDA8485) for a four-wire network.

ProtEX-MAX to RS-485 Serial Converter Connections	
RS-485 Serial Converter	ProtEX-MAX RS- 485 Connections
$\overline{\text{DI}}$	$\overline{\text{DI}}$
DO	DI
$\overline{\text{DI}}$	$\overline{\text{DO}}$
DI	DO

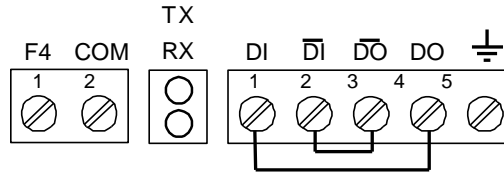
**Figure 10: ProtEX-MAX Connections to a Serial Converter**

The ProtEX-MAX has three diagnostic LEDs: a Power (P) LED to show when the module is powered properly, a Transmit Data (TX) LED to show when the module is being transmitted to by the PC side, and a Receive Data (RX) LED to show when the module is sending data to a receiving device.

The following diagrams detail how to connect the RS-485 serial communications from the ProtEX-MAX to a RS-485/RS-232 serial converter (PDA7485) in four wire and two wire configurations.

#### Three Wire Connections

In order to wire the 5 pins for use as a 3-wire half-duplex RS-485 connection, it is necessary to create a jumper connection between DI – DO and DI- – DO- as shown below.



**Figure 11. Three-Wire RS485 Connection**

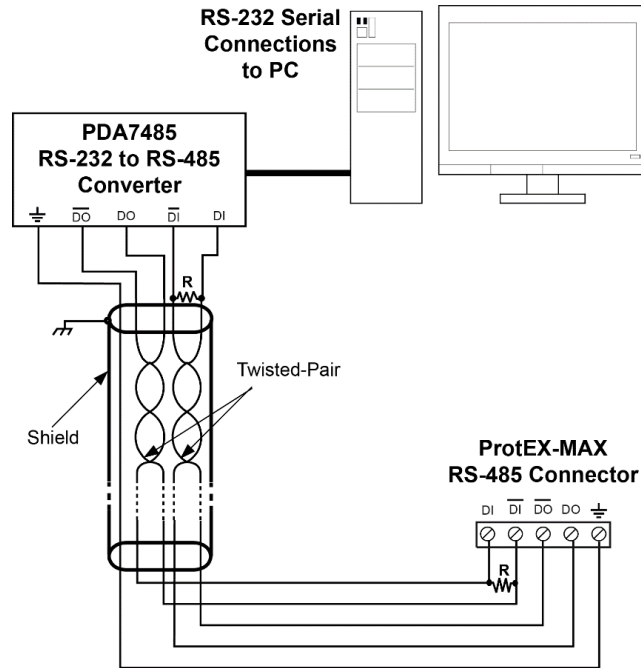



Figure 12: RS-485 Wiring

Notes:

1. Termination resistors are optional and values depend on the cable length and characteristic impedance. Consult the cable manufacturer for recommendations.
2. Refer to RS-232 to RS-485 Converter documentation for further details.
3. Use shielded cable, twisted-pairs plus ground. Connect ground shield only at one location.

 <b>WARNING</b>	<p>Observe all safety regulations. Electrical wiring should be performed in accordance with all agency requirements and applicable national, state, and local codes to prevent damage to the meter and ensure personnel safety.</p>
---	---

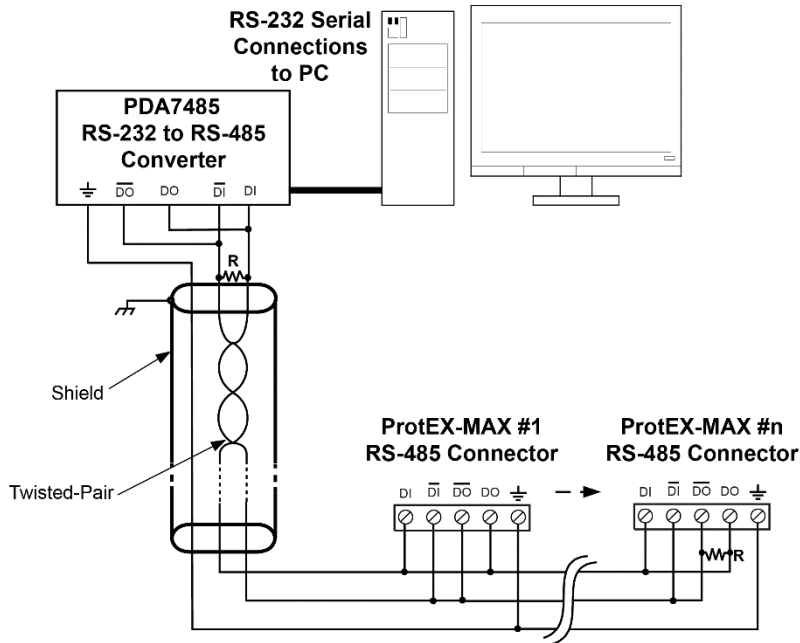



Figure 13: RS-485 Two-Wire Multi-Drop Wiring


**Notes:**

1. Termination resistors are optional and values depend on the cable length and characteristic impedance. Consult the cable manufacturer for recommendations.
2. Refer to RS-232 to RS-485 Converter documentation for further details.
3. Use shielded cable, twisted-pair plus ground. Connect ground shield only at one location.

 <b>WARNING</b>	Observe all safety regulations. Electrical wiring should be performed in accordance with all agency requirements and applicable national, state, and local codes to prevent damage to the meter and ensure personnel safety.
---	--

When using more than one instrument in a multi-drop or multi-point mode, each meter must be provided with its own unique address. See Modbus RTU Serial Communications on page 51.

**Using PROVu Serial Adapters**

 <b>NOTICE</b>	PROVu expansion modules and serial adapters are not included in the hazardous area approvals of the ProtEX-MAX. The PDA1232 and PDA8008 may be used only while the ProtEX-MAX is in a safe area, and will disable some features while installed.
--	--

PROVu expansion modules and serial adapters are not recommended for use with the ProtEX-MAX. It is recommended that any serial protocol conversion required on the RS-485 communications connection be performed using a PDA7485 RS-232 to RS-485 or PDA8485 USB to RS-485 serial converter located in a safe area.



### Relay Connections

Relay connections are made to two six-terminal connectors labeled RELAY1 – RELAY4 on Figure 3. Each relay's C terminal is common only to the normally open (NO) and normally closed (NC) contacts of the corresponding relay. The relays' C terminals should not be confused with the COM (common) terminal of the INPUT SIGNAL connector.

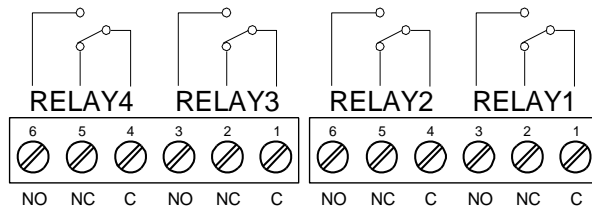


Figure 14. Relay Connections

### Switching Inductive Loads

The use of suppressors (snubbers) is strongly recommended when switching inductive loads to prevent disrupting the microprocessor's operation. The suppressors also prolong the life of the relay contacts. Suppression can be obtained with resistor-capacitor (RC) networks assembled by the user or purchased as complete assemblies. Refer to the following circuits for RC network assembly and installation:

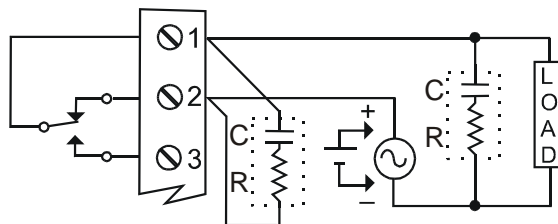


Figure 15. AC and DC Loads Protection

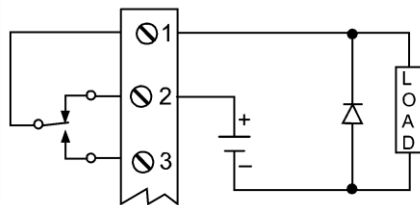
Choose R and C as follows:

R: 0.5 to 1  $\Omega$  for each volt across the contacts

C: 0.5 to 1  $\mu$ F for each amp through closed contacts

Notes:

1. Use capacitors rated for 250 VAC.
2. RC networks may affect load release time of solenoid loads. Check to confirm proper operation.
3. Install the RC network at the meter's relay screw terminals. An RC network may also be installed across the load. Experiment for best results.



Use a diode with a reverse breakdown voltage two to three times the circuit voltage and forward current at least as large as the load current.

Figure 16. Low Voltage DC Loads Protection

### RC Networks Available from Precision Digital

RC networks are available from Precision Digital and should be applied to each relay contact switching an inductive load. Part number: PDX6901.

Note: Relays are de-rated to 1/14th HP (50 watts) with an inductive load.

### 4-20 mA Output Connections

Connections for the 4-20 mA transmitter output are made to the connector terminals labeled MA OUT. The 4-20 mA output may be powered internally or from an external power supply.

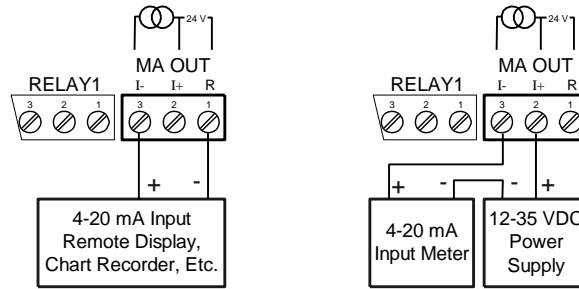


Figure 17. 4-20 mA Output Connections

### Analog Output Power Supply

If the analog output is not using the 24 VDC supply to power the output loop, it can be used for other things. The I+ Terminal is the +24 V and the R terminal is the return.

### F4 Digital Input Connections

A digital input, F4, is standard on the meter. This digital input is connected with a normally open contact across F4 and COM, or with an active low signal applied to the F4.

The functionality of the F4 input is set up in the Advanced Features, *User* menu.

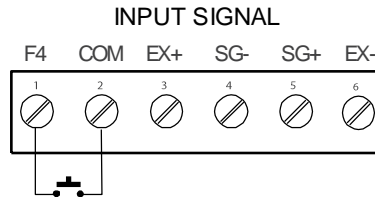


Figure 18. F4 Digital Input Connections

### Interlock Relay Feature

As the name implies, the interlock relay feature reassigns one, or more, alarm/control relays for use as interlock relay(s). Interlock contact(s) are wired to digital input(s) and trigger the interlock relay. This feature is enabled by configuring the relay, and relative digital input(s) (see page 46). In one example, dry interlock contacts are connected in series to one digital input which will be used to force on (energize) the assigned interlock power relay when all interlock contacts are closed (safe). The interlock relay front panel LED flashes when locked out. The interlock relay would be wired in-series with the load (N/O contact). See below.

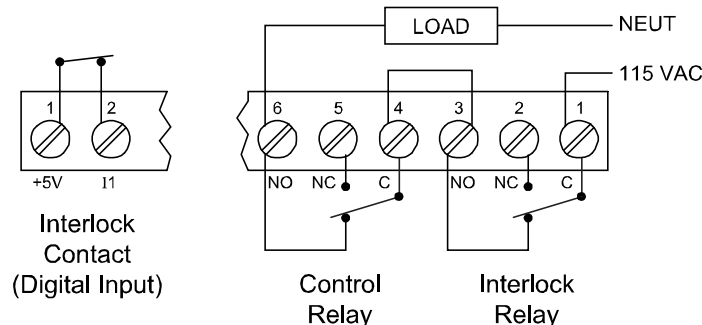
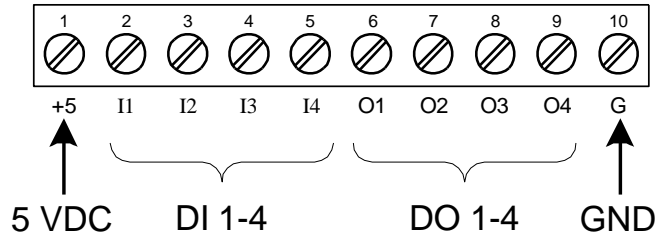


Figure 19. Interlock Connections

### Digital I/O Connections

The ProtEX-MAX has a 10 position terminal block for connecting digital inputs and outputs.



**Figure 20: Digital I/O Connections**

 <b>NOTICE</b>	<p>The onboard digital inputs (1-4) are configured at the factory to function identically to the front panel pushbuttons (Menu, F1, F2, &amp; F3) in order to work with the SafeTouch buttons. Changing the programming of the digital inputs will affect the function of the SafeTouch buttons.</p> <p>If you wish to change the behavior of the digital inputs, re-assign F1-F3 to the desired function, then change the corresponding digital input to match.</p>
 <b>WARNING</b>	<p>Observe all safety regulations. Electrical wiring should be performed in accordance with all agency requirements and applicable national, state, and local codes to prevent damage to the meter and ensure personnel safety.</p>

### External Switch Contacts

The ProtEX-MAX includes 4 digital inputs. These digital inputs are preconfigured at the factory to function as external contacts to duplicate the front button functions of the instrument. The factory configuration uses the following corresponding digital input terminals for external switch contacts.

Digital Input Connection	Factory Default Function
I1	MENU
I2	RIGHT arrow
I3	UP arrow
I4	ENTER arrow

See Digital Inputs & Outputs in the Specification on page 8 for details on the digital inputs.

 <b>NOTICE</b>	<p>The digital inputs are configured at the factory to function identically to the front panel pushbuttons in order to work with the SafeTouch buttons. Changing the programming of the digital inputs will affect the function of the SafeTouch buttons.</p>
-------------------	---

## Setup and Programming

The meter is factory calibrated prior to shipment to read in millivolts. The calibration equipment is traceable to NIST standards.

### Overview

There are no jumpers to set for the meter input selection.

Setup and programming may be done through the infrared through-glass SafeTouch buttons or using the mechanical buttons when uncovered. There is a slide switch located on the connector board. This is used to enable or disable SafeTouch Buttons.

After power and input signal connections have been completed and verified, apply power to the meter.

### SafeTouch® Buttons

The ProtEX-MAX is equipped with four sensors that operate as through-glass buttons so that it can be programmed and operated without removing the cover (and exposing the electronics) in a hazardous area.

These buttons can be disabled for security by selecting DISABLE on the switch labeled NO-CONTACT BUTTONS located on the connector board.

To actuate a button, press one finger to the glass directly over the marked button area. Then retract finger more than three inches from the glass before pressing the next button. When the cover is removed, the four mechanical buttons located next to the sensors are used. The sensors are disabled when a mechanical button is pressed and will automatically be re-enabled after 60 seconds of inactivity.

The SafeTouch Buttons are designed to filter normal levels of ambient interference and to protect against false triggering, however, it is recommended that the SafeTouch Buttons be disabled (slide switch to LOCK) if there is an infrared interference source in line-of-sight to the display.

The SafeTouch Buttons are configured by default to duplicate the function of the front panel mechanical pushbuttons associated with the integrated meter. The symbols by each SafeTouch button correspond to a mechanical button as shown in the table on the next page.

SafeTouch Button Tips:

- To the extent possible, install the display facing away from sunlight, windows, reflective objects and any sources of infrared interference.
- Keep the glass window clean.
- Tighten the cover securely.
- Use a password to prevent tampering.











**WARNING**

Take caution when cleaning the window glass as it may result in unintentional SafeTouch button events. Only clean the ProtEX-MAX when the system is safely shut down and inspect the ProtEX-MAX for proper configuration prior to system restart.

## Front Buttons and Status LED Indicators



Button Symbol	Description	LED	Status
 	<b>Menu</b>	1-8	Alarm 1-8 indicator
 	<b>Right arrow/F1 Zero Meter</b>	1-8 M	Flashing: Relay in manual control mode
 	<b>Up arrow/F2 Reset Tare</b>	T G	Flashing: Tare (Net) Gross
 	<b>Enter/F3 Tare</b>	1-4	Flashing: Relay interlock switch open
<p><i>Note:</i> F4 is a digital input</p>		<p><i>Note:</i> LEDs for relays in manual mode flash with the "M" LED every 10 seconds.</p>	

- Press the Menu button to enter or exit the Programming Mode at any time.
- Press the Right arrow button to move to the next digit during digit or decimal point programming.
- Press or hold the Up arrow button to scroll through the menus, decimal point, or to increment the value of a digit.
- Press the Enter button to access a menu or to accept a setting.
- Press and hold the Menu button for three seconds to access the advanced features of the meter.

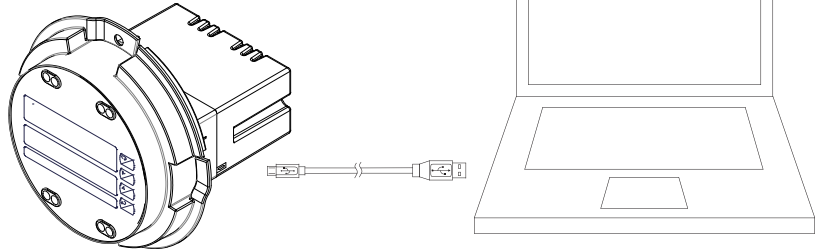
## MeterView® Pro Software

The meter can also be programmed using the PC-based MeterView Pro software included with the meter. This software can be installed on any Microsoft® Windows® (XP/Vista/7/8/10) computer by connecting the meter's onboard USB. The meter is powered by the USB connection, so there is no need to wire anything prior to programming the meter, though USB is intended only for meter configuration.

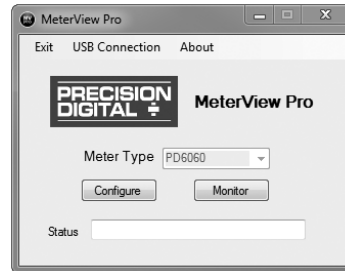
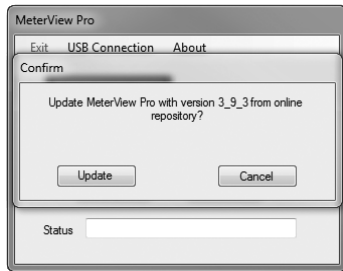
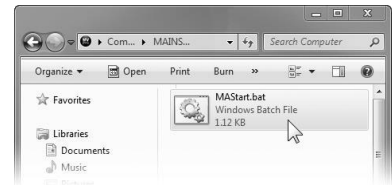
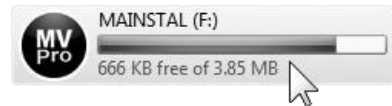
### MeterView Pro Installation

1. Connect one end of the provided USB cable to the meter and the other end to the computer. The computer will automatically install the driver software it needs to talk to the meter.

**Only one meter may be connected at a time. Attaching multiple meters will cause a conflict with the meter software.**



2. Once the driver is installed, an AutoPlay dialog should appear for the drive "MAINSTAL." Click "Open folder to view files." If the computer does not display an AutoPlay dialog for the drive "MAINSTAL," you should open My Computer and double-click on the drive labeled "MAINSTAL."
3. Double-click on the file named "MAStart." The program will open a few windows and install two programs on your computer. Simply follow the onscreen instructions until you see one of the dialogs below. If you receive a "User Account Control" warning, click "Yes."
4. If there is an update available, click the "Update" button to install the new version. Otherwise, click "Configure" to begin programming your meter.



**Note:** If you decide to update your MeterView Pro software, once the installation has completed, you will be asked if you want to update the setup files located on the meter itself. This way, you will always have the most current version on the meter for future installs.



**Warning!**

**Do not unplug the meter while the new installation files are being written to it. The meter will display uwrite during the process and you will receive an onscreen notification once the process is complete.**

Data logging for one meter at a time is available with MeterView Pro software. More advanced data acquisition may be accomplished by using any Modbus RTU compliant software. Additional information regarding configuration and monitoring of the meter using MeterView Pro software is available online. Go to [www.predig.com/meterview-pro](http://www.predig.com/meterview-pro).



## Display Functions & Messages

The meter displays various functions and messages during setup, programming, and operation. The following table shows the main menu functions and messages in the order they appear in the menu.

Display	Parameter	Action/Setting Description	Display	Parameter	Action/Setting Description
SETUP	Setup	Enter Setup menu	SCALE 1	Scale 1	Enter the Scale menu for PV1
INPUT	Input	Enter Input selection menu	SCALE 2	Scale 2	Enter the Scale menu for PV2
POLAR	Polar	Enter unipolar or bipolar selection menu	CAL	Calibrate	Enter the Calibration menu
UNI	Unipolar	Press Enter to select operation with positive signals only (e.g. 0-30 mV)	INP 1	Input 1	Calibrate input 1 signal or program input 1 value
BI	Bipolar	Press Enter to select operation with positive & negative signals (e.g. $\pm 15$ mV)	DIS 1	Display 1	Program display 1 value
RANGE	Range	Enter range selection menu	INP 2	Input 2	Calibrate input 2 signal or program input 2 value (up to 32 points)
15 mV	15 mV	Set meter for 15 mV input (uni/bi)	DIS 2	Display 2	Program display 2 value (up to 32 points)
25 mV	25 mV	Set meter for $\pm 25$ mV input (bi)	ERROR	Error	Error, calibration not successful, check signal or programmed value
30 mV	30 mV	Set meter for 30 mV input (uni)	DISPLAY	Display	Enter the Display menu
150 mV	150 mV	Set meter for 150 mV input (uni/bi)	LINE 1	Line 1	Press Enter to assign the upper display parameter (default: PV)
250 mV	250 mV	Set meter for $\pm 250$ mV input (bi)	LINE 2	Line 2	Press Enter to assign the lower display parameter (default: engineering units)
300 mV	300 mV	Set meter for 300 mV input (uni)	DIS INT	Display intensity	Set display intensity level from 1 to 8
RATIO	Ratiometric	Press Enter to select ratiometric operation to compensate for excitation changes.	RELAY	Relay	Enter the Relay menu
DUAL	Dual-Scale	Press Enter to select dual-scale display (Select Yes or No)	REL 1	Relay 1	Relay 1 setup
UNITS	Units	Select the display units/tags	ACT 1	Action 1	Set relay 1 action
DEC PT	Decimal point	Set decimal point	RESET	Automatic	Set relay for automatic reset
PV 1	PV1	PV1 decimal point (dual-scale)	RMAN	Auto-manual	Set relay for automatic & manual reset any time
PV 2	PV2	PV2 decimal point (dual-scale)	LATCH	Latching	Set relay for latching operation
PROG	Program	Enter the Program menu			
SCALE	Scale	Enter the Scale menu			

Display	Parameter	Action/Setting Description	Display	Parameter	Action/Setting Description
Latching-cleared	<i>Latching-cleared</i>	Set relay for latching operation with manual reset only after alarm condition has cleared	Output 2	<i>Output 2</i>	Program output 2 value (e.g. 20.000 mA)
Alternate	<i>Alternate</i>	Set relay for alternation control	Reset	<i>Reset</i>	Press Enter to access the <i>Reset</i> menu
Sampling	<i>Sampling</i>	Set relay for sampling operation	Reset high	<i>Reset high</i>	Press Enter to reset max display
Off	<i>Off</i>	Disable relay and front panel status LED (Select Off to enable Interlock feature)	Reset low	<i>Reset low</i>	Press Enter to reset min display
Set 1	<i>Set 1</i>	Program set point 1	Reset high & low	<i>Reset high &amp; low</i>	Press Enter to reset max & min displays
Reset 1	<i>Reset 1</i>	Program reset point 1	Reset tare	<i>Reset tare</i>	Press Enter to reset tare
Relay 2	<i>Relay 2</i>	Relays 2-4 setup	Tare	<i>Tare</i>	Enter <i>Tare</i> menu
Fail-safe	<i>Fail-safe</i>	Enter <i>Fail-safe</i> menu	Capture	<i>Capture</i>	Press Enter to set meter to capture tare using the Tare button
Fail-safe 1	<i>Fail-safe 1</i>	Set relay 1 fail-safe operation	Programmable	<i>Programmable</i>	Press Enter to set meter to programmable tare and enter a value
On	<i>On</i>	Enable fail-safe operation	Off	<i>Off</i>	Press Enter to disable the tare function
Fail-safe 2	<i>Fail-safe 2</i>	Set relays 2-4 fail-safe operation	Control	<i>Control</i>	Enter <i>Control</i> menu
Delay	<i>Delay</i>	Enter relay <i>Time Delay</i> menu	Automatic	<i>Automatic</i>	Press Enter to set meter for automatic operation
Delay 1	<i>Delay 1</i>	Enter relay 1 time delay setup	Manual	<i>Manual</i>	Press Enter to manually control relays or analog output operation
On 1	<i>On 1</i>	Set relay 1 On time delay	Password	<i>Password</i>	Enter the <i>Password</i> menu
Off 1	<i>Off 1</i>	Set relay 1 Off time delay	Password 1	<i>Password 1</i>	Set or enter Password 1
Delay 2	<i>Delay 2</i>	Enter relays 2-4 time delay setup	Password 2	<i>Password 2</i>	Set or enter Password 2
Analog output	<i>Analog output</i>	Enter the <i>Analog output</i> scaling menu	Password 3	<i>Password 3</i>	Set or enter Password 3
Display 1	<i>Display 1</i>	Program display 1 value	Unlocked	<i>Unlocked</i>	Program password to lock meter
Output 1	<i>Output 1</i>	Program output 1 value (e.g. 4.000 mA)	Locked	<i>Locked</i>	Enter password to unlock meter
Display 2	<i>Display 2</i>	Program display 2 value	Flashing	<i>Flashing</i>	Over/under range condition

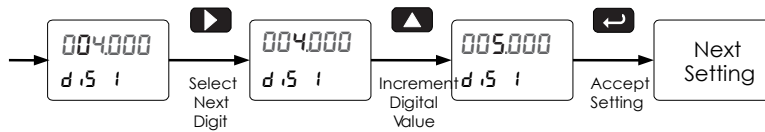
## Setting Numeric Values

The numeric values are set using the Right and Up arrow buttons. Press Right arrow to select next digit and Up arrow to increment digit value.

The digit being changed is displayed brighter than the rest.

Press and hold up arrow to auto-increment the display value.

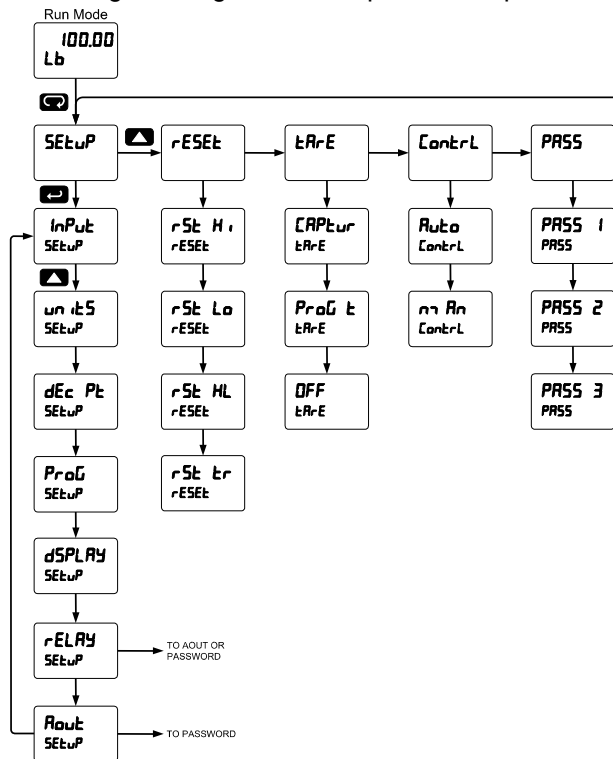
Press the Enter button, at any time, to accept a setting or Menu button to exit without saving changes.



## Main Menu

The main menu consists of the most commonly used functions: *Setup*, *Reset*, *Tare*, *Control*, and *Password*.

- Press Menu button to enter Programming Mode then press the Up arrow button to scroll main menu.

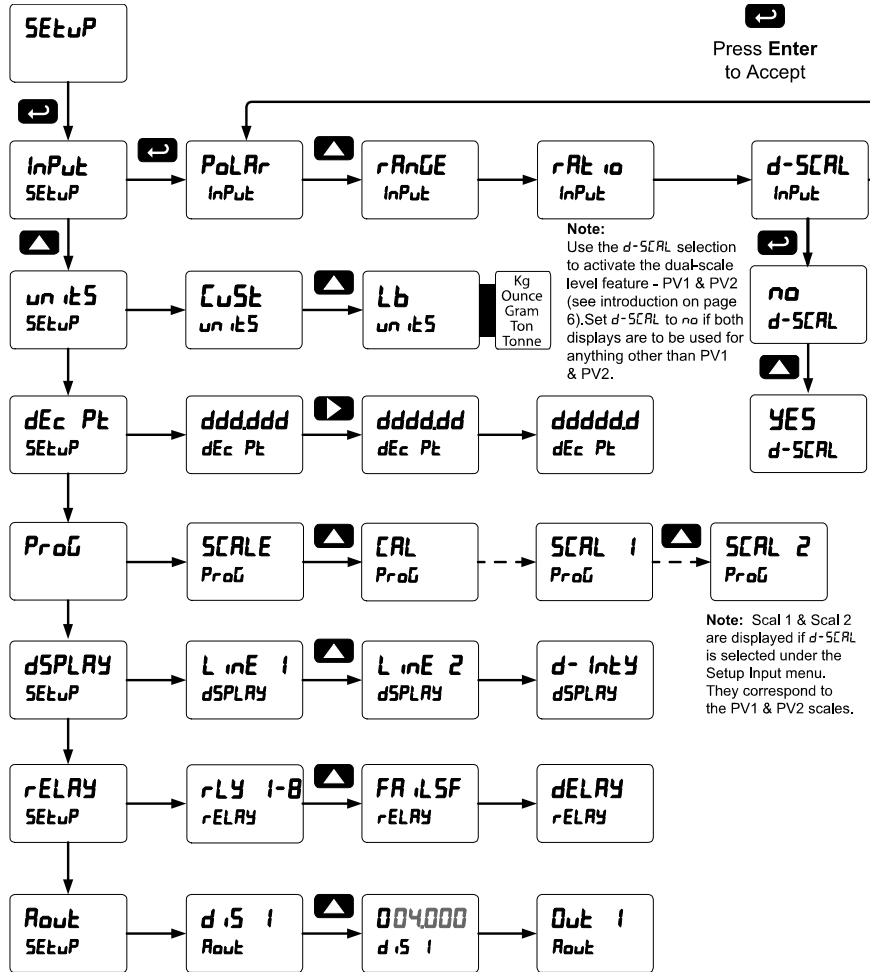


- Press Menu, at any time, to exit and return to Run Mode. Changes made to settings prior to pressing Enter are not saved.
- Changes to the settings are saved to memory only after pressing Enter.
- The display moves to the next menu every time a setting is accepted by pressing Enter.

## Setting Up the Meter (SEtUP)

The *Setup* menu is used to select:

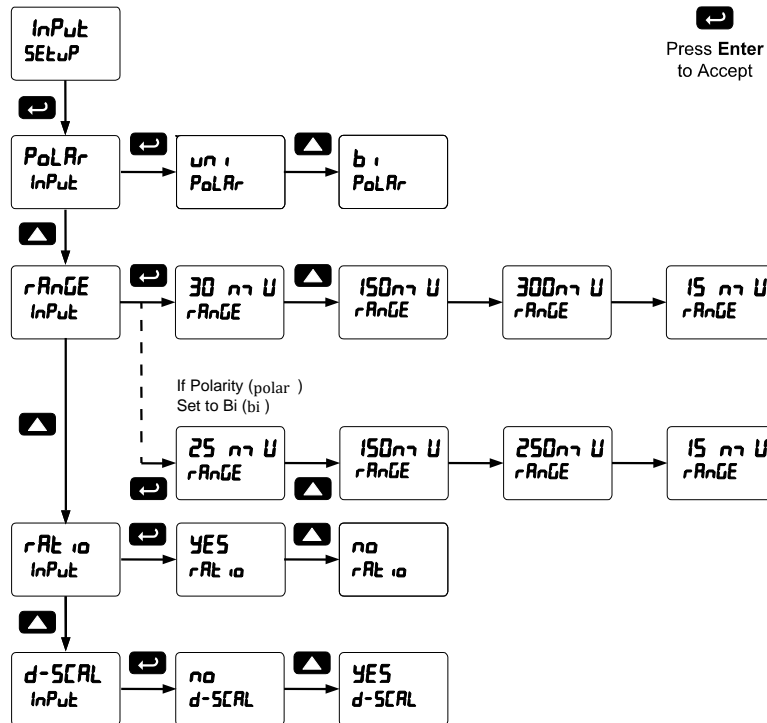
1. Unipolar (e.g. 0-30 mV) or bipolar (e.g.  $\pm 25$  mV) polarity, input range, ratiometric operation, and dual-scale feature
2. Engineering units
3. Decimal point position
4. Program scaling or live calibration
5. Display parameter and intensity
6. Relay operation
7. 4-20 mA analog output scaling



### Setting the Input Signal ( *inPut* )

Enter the *Input* menu to set up the input polarity, range, ratiometric operation, and dual-scale feature. The meter is capable of accepting any signal from -250 to 250 mV in bipolar mode or up to 300 mV in unipolar mode.

After selecting “Yes” or “No” for *ratio*, *d-SCAL* is displayed. Selecting “Yes” enables the dual-scale feature, allowing scaling of the same input in two different scales (for PV1 & PV2) or displaying the percentage of PV1.



#### Input Polarity Selection ( *PoLAR* )

Select unipolar operation for inputs in ranges from 0 to 300 mV and select bipolar operation for inputs in ranges from -250 mV to +250 mV. This setting determines the selectable ranges for the millivolt input

#### Range Selection ( *RANGE* )

This menu is used to select the input range. The selections listed are determined by the *Polarity* setting.

Unipolar mode: 0-15, 0-30, 0-150, 0-300 mV

Bipolar mode: ±15, ±25, ±150, ±250 mV

#### Ratiometric Operation ( *rRAt io* )

Ratiometric operation corrects the measured strain gauge signal for up to ±5% variation of either the internal or external excitation power supply. In order to use the ratiometric operation, the ratiometric operation menu must be set to yes (YES).

#### Dual-Scale ( *d-SCAL* )

The analog input can be displayed in two different scales, by enabling the dual-scale feature in the *Setup-Input* menu, see page 31.

To enable the dual-scale feature you must select d-SCAL in the Input selection menu.

### Setting the Input Units (Units)

Enter the pre-defined engineering unit or custom unit. The pre-defined units have automatic conversion factors. This unit will be displayed if *Unit* is selected as the lower display parameter. See the flow chart on page 36 to access the display menu to show the unit on the lower display.

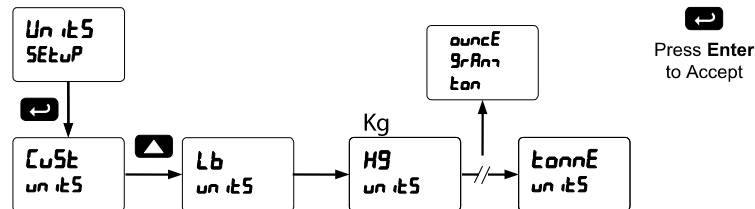
The custom unit may also be used to enter a display tag.

**Pre-defined engineering units:** lb, kg, ounce, gram, ton (short), tonne (metric ton). The meter converts the reading according to the unit selected (e.g. 100.00 lb = 45.36 kg = 45359.2 g = 1600 oz).

**Unit Conversions:** After scaling values in the *Scale* menu have been entered during setup, automatic unit conversions are done when switching from any standard unit to any other standard unit during future changes of the *Units* menu.

Once a standard unit has been selected in the units menu, the user must then set their scaling values for that unit (under the setup menu) in order for that unit's conversion factor to take effect. Otherwise, the meter will allow the user to freely switch between standard unit selections, without applying a conversion factor.

Note that if the dual-scale feature is selected in the *Setup* menu, both PV1 and PV2 will be converted from the original standard unit to the new standard unit. A scaled PV not scaled for the selected units must be reprogrammed. *Example:* If PV 1 is scaled for pounds, and PV 2 scaled for gallons; if the *Unit* selection is changed from *Lb* to *ounce*, PV 2 will need to re-scaled manually back to gallons.



*Note: PV1 and PV2 may use different standard units as starting points, however the user must select the unit and complete scaling for both PV1 and PV2 individually. For example, set PV1 equal to "Lbs" and complete the scaling for PV1 only. PV1 is now reading in Lbs. Then, change the units for PV2 to be "Kg" and complete the scaling for PV2. PV2 will read in kilograms and PV1 will reflect the conversion from Lbs to Kgs.*

### Setting the Input Units or Custom Tags (uN t5)

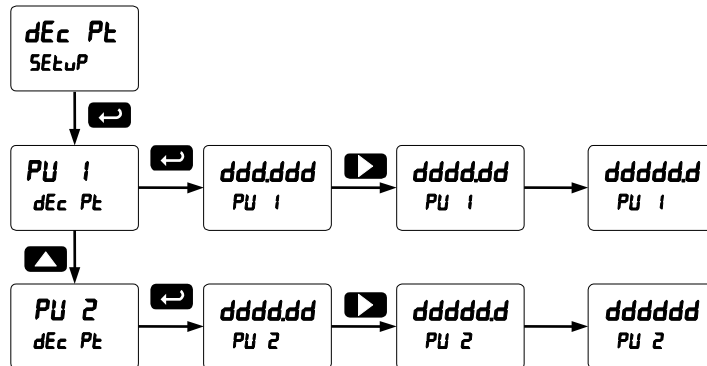
Enter the input unit or custom tag that will be displayed if units are selected in the uN t5 menu, or d uN t5 is selected as the lower display parameter. See the flow chart on page 36 to access the display menu to show the unit or tag on the lower display. The engineering units or custom legends can be set using the following 7-segment character set:

0	0	C	C	K	K	V	V
1	1	c	c	L	L	w	w
2	2	d	d	m	m	X	X
3	3	E	E	n	n	Y	Y
4	4	F	F	O	O	Z	Z
5	5	G	G	o	o	-	-
6	6	g	g	P	P	/	/
7	7	H	H	q	q	[	]
8	8	h	h	r	r	]	[
9	9	i	i	S	S	=	=
A	A	l	l	t	t	°	Degree(<)
b	b	J	J	u	u		Space

Notes: Degree symbol represented by (<) if programming with MeterView® Pro. The letters “m” and “w” use two 7-segment LEDs each; when selected the characters to the right are shifted one position. Press and hold up arrow to auto-scroll the characters in the display.

### Setting the Decimal Point (dEc Pt)

The decimal point may be set with up to five decimal places or with no decimal point at all. Pressing the Right arrow moves the decimal point one place to the right until no decimal point is displayed, and then it moves to the leftmost position. Pressing the Up arrow moves the decimal point to the left. If the dual-scale feature is selected, the decimal point selections for PV1 & PV2 are enabled.



### Programming the Meter (Prog)

The *Program* menu contains the *Scale* and the *Calibrate* menus.

For strain gauge and load cell applications it is **recommended to calibrate** the meter using the sensor as the input and with ratiometric operation enabled to compensate for small variation in the excitation voltage.

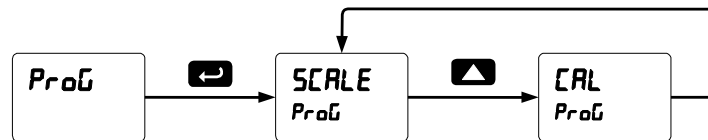
It is **very important** to read the following information, before proceeding to program the meter:

- The meter is factory calibrated prior to shipment to read in millivolts. The calibration equipment is traceable to NIST standards.
- Use the *Scale* menu to scale the input (e.g. 0-100 mV). A calibrated signal source is not needed to scale the meter.
- The PD8-6100 is a single input meter with dual-scale capability.

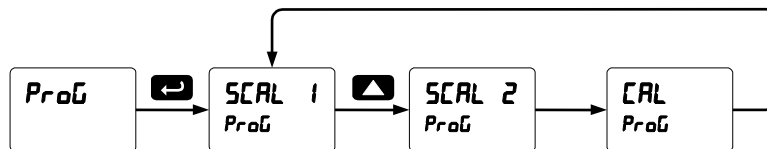
If the dual-scale feature is selected in the *Setup* menu, the *Scale 1* and *Scale 2* menus are enabled for PV1 & PV2 respectively.

The process inputs may be calibrated or scaled to any display value within the range of the meter.

#### Program Menu for Single Scale Process



#### Program Menu for Dual-Scale Applications



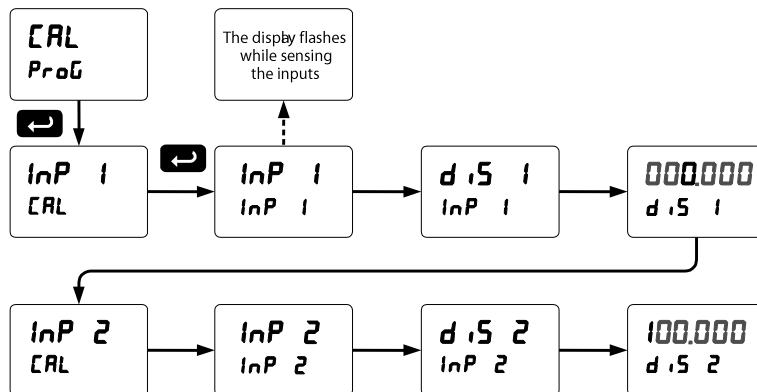
Additional parameters, not needed for most applications, are programmed in the *Advanced Features* menu; see *Advanced Features Menu*, page 49.

### Calibrating the Meter with Strain Gauge/Load Cell (CAL)

To scale the meter without a signal source, refer to *Scaling the Meter (SCALE)*, page 35.

The meter can be calibrated to display the process variable in engineering units by applying the appropriate input signal and following the calibration procedure.

The use of a calibrated signal source is strongly recommended to calibrate the meter.



Warm up the meter for at least 15 minutes before performing calibration to ensure specified accuracy.

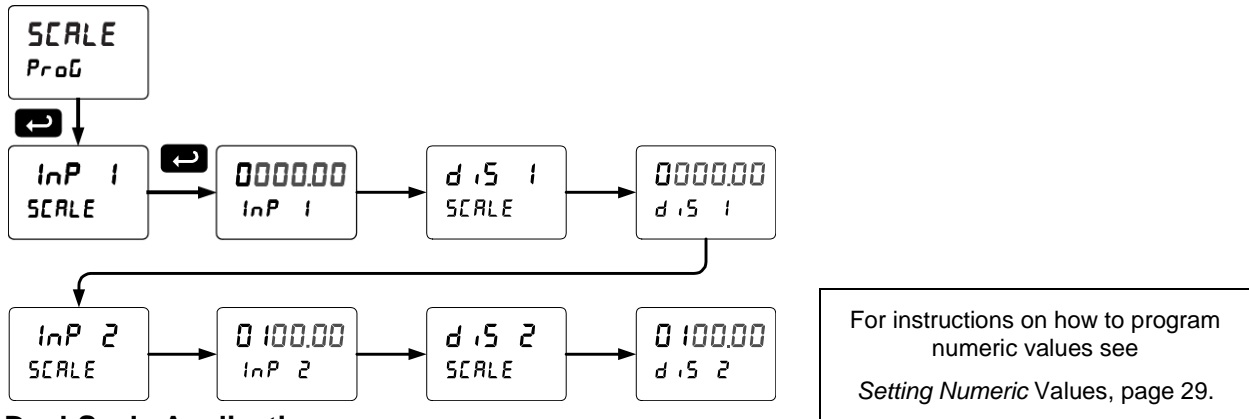


### Multi-Point Calibration & Scaling

The meter is set up at the factory for 2-point linear calibration. The number of points for multi-point calibration/scaling is set up in the *Advanced Features* menu. Up to 32 linearization points may be selected for PV1 and up to 8 linearization points may be selected for PV2. See page 53 for details.

#### Scaling the Meter (SCALE)

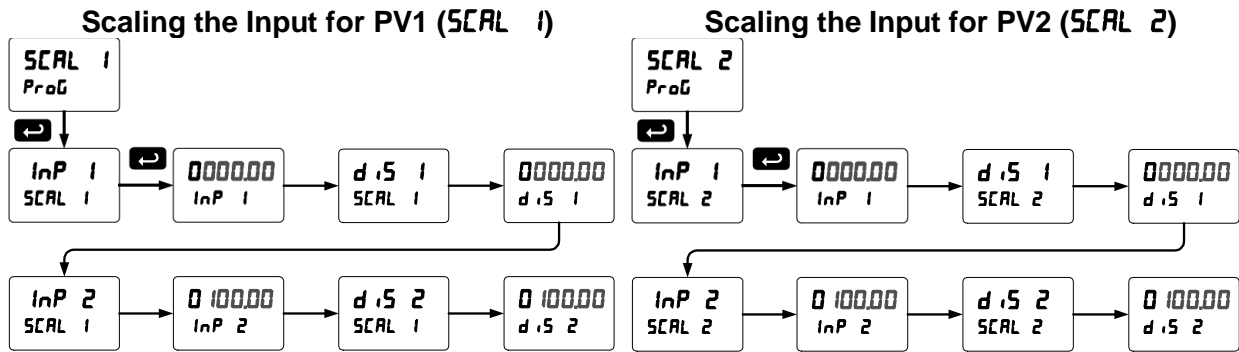
The strain gauge input (e.g. 0-100 mV) can be scaled to display the process variable in engineering units. A signal source is not needed to scale the meter; simply program the inputs and corresponding display values.



#### Dual-Scale Application

The analog input can be displayed in two different scales, by enabling the dual-scale feature in the *Setup Input* menu, see page 31.

To enable the dual-scale feature you must select it in the Input selection menu.



#### Error Message (Error)

An error message indicates that the calibration or scaling process was not successful.

After the error message is displayed, the meter reverts to input 2 during calibration or scaling and to input 1 during internal calibration, allowing the appropriate input signal to be applied or programmed.

The error message might be caused by any of the following conditions:

1. Input signal is not connected to the proper terminals or it is connected backwards.
2. Wrong signal selection in *Setup* menu.
3. Minimum input span requirements not maintained.
4. Input 1 signal inadvertently applied to calibrate input 2.

#### Minimum Input Span

The minimum input span is the minimum difference between input 1 and input 2 signals required to complete the calibration or scaling of the meter.

Input Range	Input 1 & Input 2 Span
15 mV	0.2 mV
25 mV, 30 mV	0.4 mV
150 mV	2.0 mV
250 mV, 300 mV	4.0 mV

### Setting the Display Parameter & Intensity (dSPRAY)

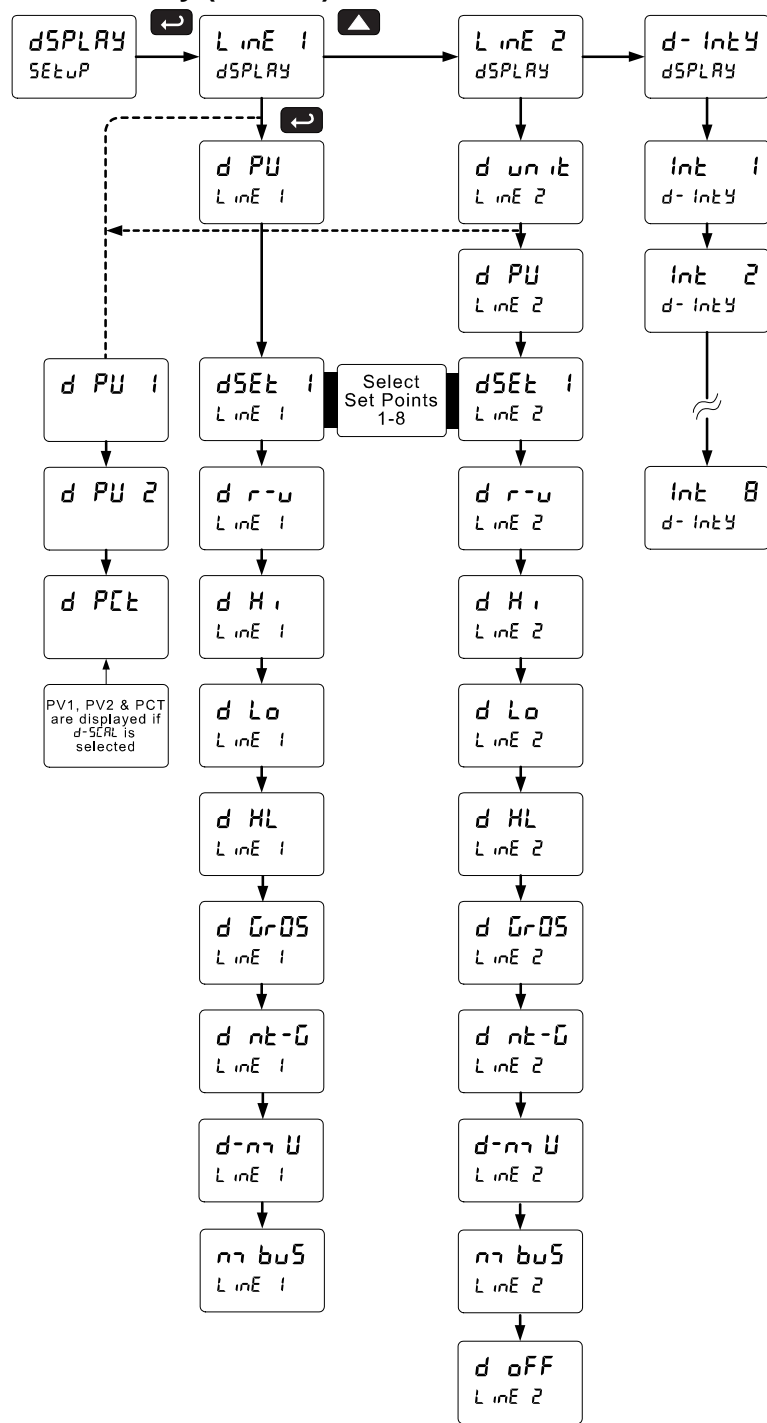
Display line 1 (LINE 1) can be programmed to display:

1. Process value 1 (PV1)
2. Process value 2 (PV2)
3. Percent of PV1 (PCt)
4. Relay set points
5. Toggle process value & units
6. Max & min values
7. Gross value
8. Toggle net & gross values
9. Input millivolts
10. Modbus input

Display line 2 (LINE 2) can be programmed to display:


1. Engineering units or custom legends
2. Process value 1 (PV1)
3. Process value 2 (PV2)
4. Percent of PV1 (PCt)
5. Relay set points
6. Toggle process value & units
7. Max & min values
8. Gross value
9. Toggle net & gross values
10. Input millivolts
11. Modbus input
12. Off (no display)

**Display Intensity:** The meter has eight display intensity levels to give the best performance under various lighting conditions. Select intensity 8 for outdoor applications. The default intensity setting is 8.



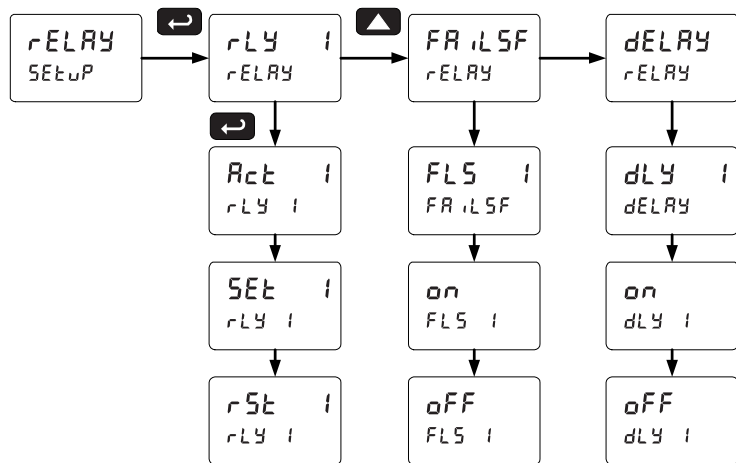
## Setting the Relay Operation (rELAY)

This menu is used to set up the operation of the relays.



**Caution!** During setup, the relays do not follow the input and they will remain in the state found prior to entering the Relay menu.

1. Relay action
  - a. Automatic reset only (non-latching)
  - b. Automatic + manual reset at any time (non-latching)
  - c. Latching (manual reset only)
  - d. Latching with Clear (manual reset only after alarm condition has cleared)
  - e. Pump alternation control (automatic reset only)
  - f. Sampling (the relay is activated for a user-specified time)
  - g. Off (relay state controlled by Interlock feature)
2. Set point
3. Reset point
4. Fail-safe operation
  - a. On (enabled)
  - b. Off (disabled)
5. Time delay
  - a. On delay (0-999.9 seconds)
  - b. Off delay (0-999.9 seconds)



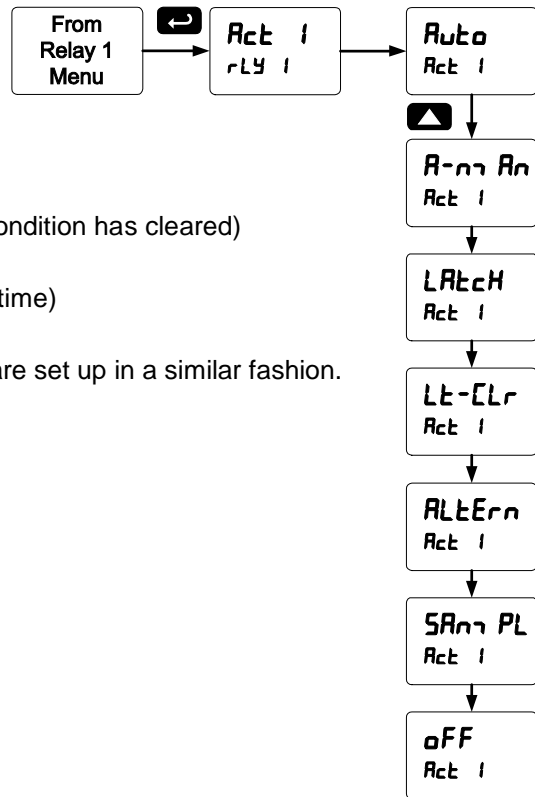
Note: The setup of relays 2-8 follows the same pattern shown here for relay 1.

### Setting the Relay Action

Operation of the relays is programmed in the *Action* menu. The relays may be set up for any of the following modes of operation:

1. Automatic reset (non-latching)
2. Automatic + manual reset at any time (non-latching)
3. Latching (manual reset only, at any time)
4. Latching with Clear (manual reset only after alarm condition has cleared)
5. Pump alternation control (automatic reset only)
6. Sampling (the relay is activated for a user-specified time)
7. Off (relay state controlled by Interlock feature)

The following graphic shows relay 1 action setup; relay 2-4 are set up in a similar fashion.



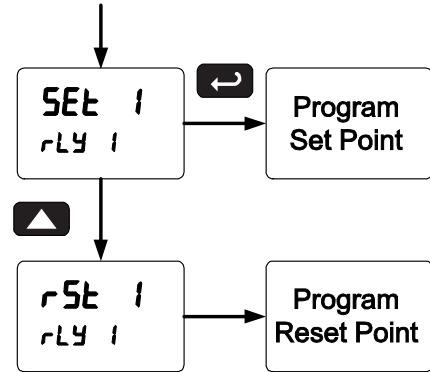
### Programming Set and Reset Points

High alarm indication: program set point above reset point.

Low alarm indication: program set point below reset point.

The deadband is determined by the difference between set and reset points. Minimum deadband is one display count. If the set and reset points are programmed with the same value, the relay will reset one count below the set point.

*Note: Changes are not saved until the reset point has been accepted.*



### Setting Fail-Safe Operation

In fail-safe mode of operation, the relay coil is energized when the process variable is within safe limits and the relay coil is de-energized when the alarm condition exists. The fail-safe operation is set independently for each relay. Select **on** to enable or select **oFF** to disable fail-safe operation.

### Programming Time Delay

The *On* and *Off* time delays may be programmed for each relay between 0 and 999.9 seconds. The relays will transfer only after the condition has been maintained for the corresponding time delay.

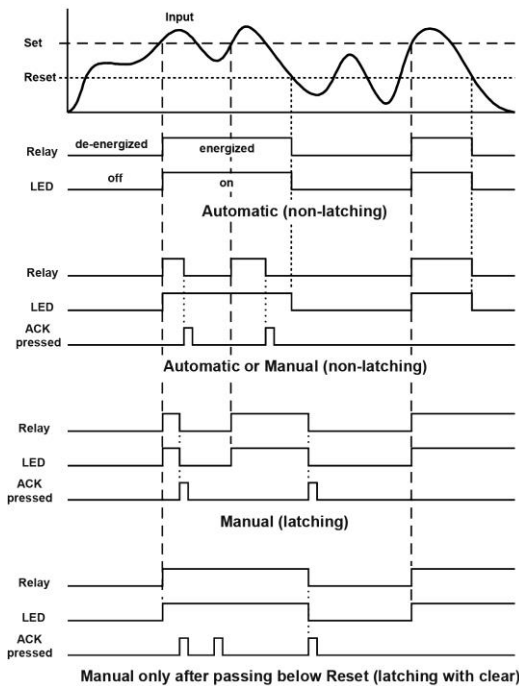
The *On* time delay is associated with the set point.

The *Off* time delay is associated with the reset point.

### Relay and Alarm Operation Diagrams

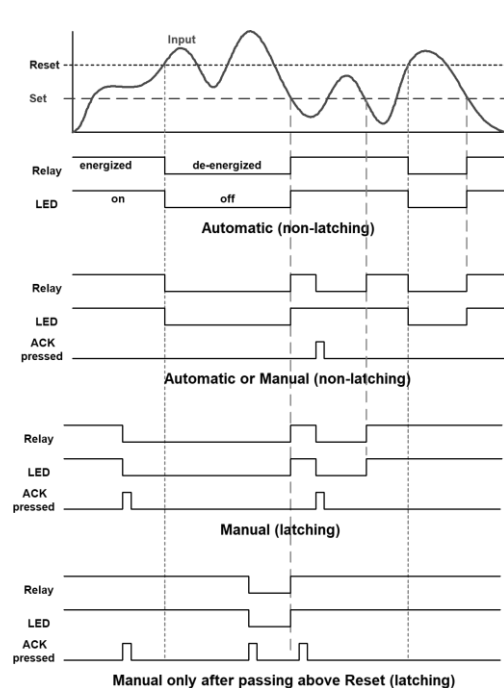
The following graphs illustrate the operation of the relays, status LEDs, and ACK button.

#### High Alarm Operation (Set > Reset)



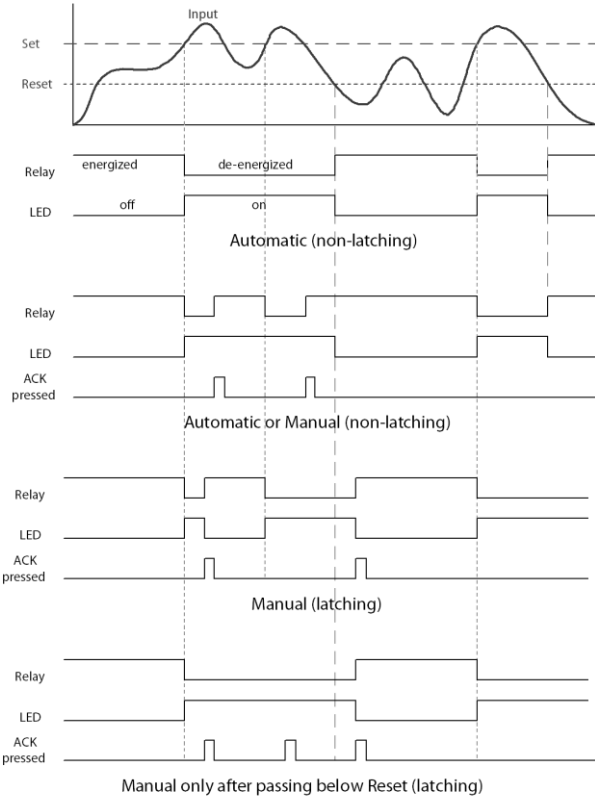
For Manual reset mode, ACK can be pressed anytime to turn "off" relay. To detect a new alarm condition, the signal must go below the set point, and then go above it.

#### Low Alarm Operation (Set < Reset)

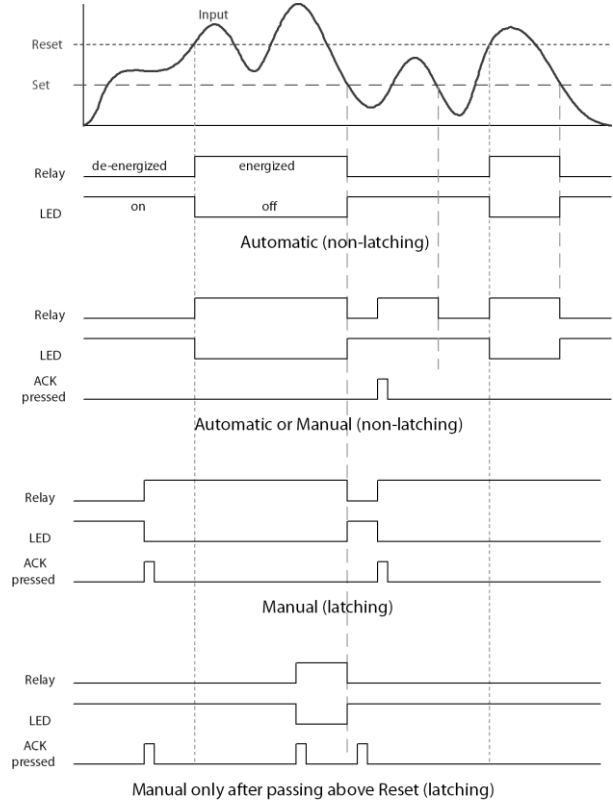


For Manual reset mode, ACK can be pressed anytime to turn "off" relay. For relay to turn back "on", signal must go above set point, and then go below it.

### High Alarm with Fail-Safe Operation (Set > Reset)

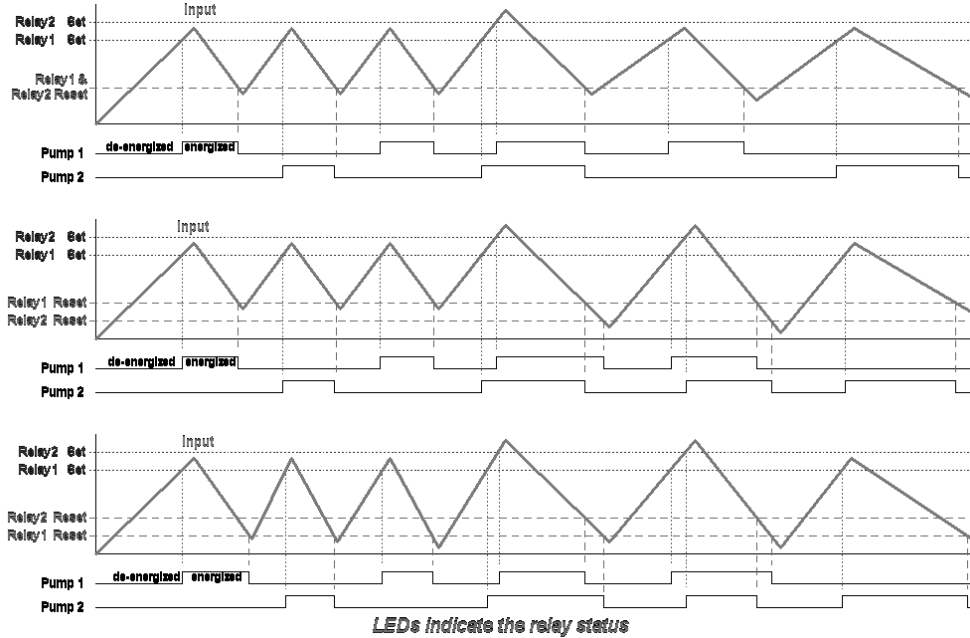


### Low Alarm with Fail-Safe Operation (Set < Reset)

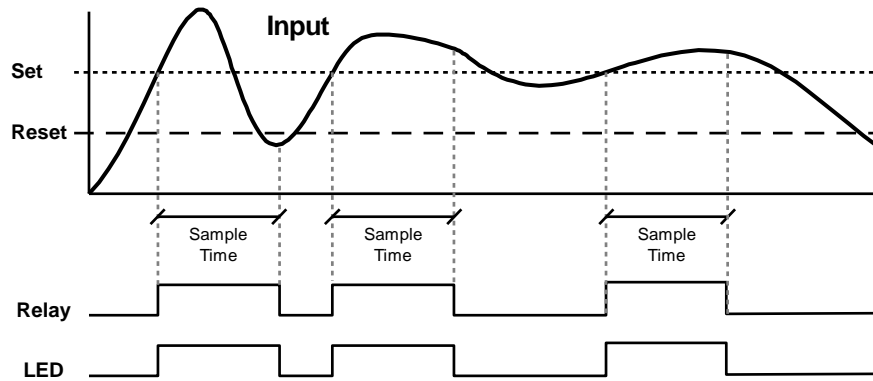


Note: Relay coil is energized in non-alarm condition. In case of power failure, relay will go to alarm state.

### Pump Alternation Control Operation



### Relay Sampling Operation

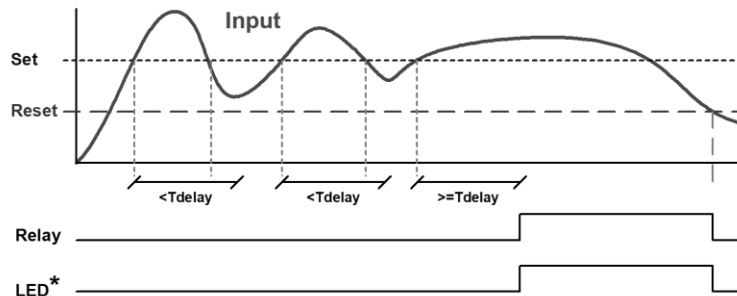


When the signal crosses the set point, the relay trips and the sample time starts. After the sample time has elapsed, the relay resets. The cycle repeats every time the set point is crossed, going up for high alarms and going down for low alarms.

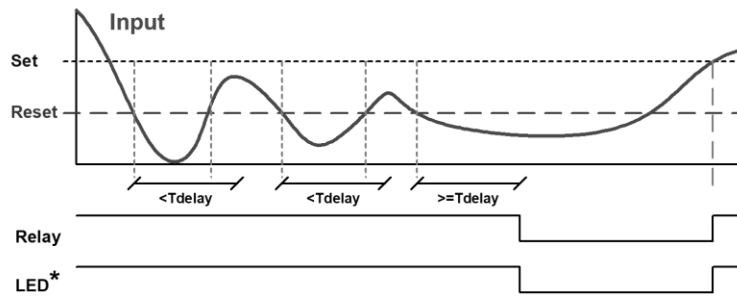
The sample time can be programmed between 0.1 and 5999.9 seconds.

### Time Delay Operation

The following graphs show the operation of the time delay function.



On Time Delay



Off Time Delay

When the signal crosses the set point, the *On* time delay timer starts and the relay trips when the time delay has elapsed. If the signal drops below the set point (high alarm) before the time delay has elapsed, the *On* time delay timer resets and the relay does not change state. The same principle applies to the *Off* time delay.

*Note: If "Automatic or Manual (R-nn Rn)" reset mode is selected, the LED follows the reset point and not the relay state when the relay is acknowledged.*

## Relay Operation Details

### Overview

The relay capabilities of the meter expand its usefulness beyond simple indication to provide users with alarm and control functions. These capabilities include front panel alarm status LEDs as well as either 2 or 4 optional internal relays. Typical applications include high or low force, level, or pressure alarms, control applications such as simple on/off control, and relay alternation control for up to 4 pumps. There are four basic ways the relays can be used:

1. High or Low Alarms with Latching or Non-Latching Relays
2. Simple On/Off Control with 100% Adjustable Deadband
3. Sampling (Based on Time)
4. Alternation Control for up to 4 Pumps

### Relays Auto Initialization

When power is applied to the meter, the front panel LEDs and alarm relays will reflect the state of the input to the meter. The following table indicates how the alarm LEDs and relays will react on power-up based on the set and reset points.

Alarm #	HI or LO Alarm	Set Point	Reset Point	Power-Up Reading	Relay & LED
1	HI	1000	500	499	Off
2	LO	700	900	499	On
3	LO	250	400	499	Off
4	HI	450	200	499	On

### Fail-Safe Operation

The following table indicates how the relays behave based on the fail-safe selection for each relay:

Fail-Safe Selection	Non-Alarm State		Alarm State		Power Failure
	NO	NC	NO	NC	
Off	Open	Closed	Closed	Open	Relays go to non-alarm state
On	Closed	Open	Open	Closed	Relays go to alarm state

*Note: NO = Normally Open, NC = Normally Closed. This refers to the condition of the relay contacts when the power to the meter is off.*

### Front Panel LEDs

The LEDs on the front panel provide status indication for the following:

The meter is supplied with four alarm points that include front panel LEDs to indicate alarm conditions. This standard feature is particularly useful for alarm applications that require visual-only indication. The LEDs are controlled by the set and reset points programmed by the user. When the display reaches a set point for a high or low alarm, the corresponding alarm LED will turn on. When the display returns to the reset point the LED will go off. The front panel LEDs respond differently for latching and non-latching relays.

LED	Status
1	Alarm 1
2	Alarm 2
3	Alarm 3
4	Alarm 4

LED	Status
5	Alarm 5
6	Alarm 6
7	Alarm 7
8	Alarm 8

For non-latching relays, the LED is always off during normal condition and always on during alarm condition, regardless of the state of the relay (e.g. Relay acknowledged after alarm condition).

For latching relays, the alarm LEDs reflect the status of the relays, regardless of the alarm condition. The following tables illustrate how the alarm LEDs function in relation to the relays and the acknowledge button (Default: F3 key assigned to ACK).




### Latching and Non-Latching Relay Operation

The relays can be set up for latching (manual reset) or non-latching (automatic reset) operation.

The On and Off terminology does not refer to the status of the relay's coil, which depends on the fail-safe mode selected.

Relay terminology for following tables	
Terminology	Relay Condition
On	Alarm (Tripped)
Off	Normal (Reset)
Ack	Acknowledged



**Warning!** *In latching relay mode, latched relays will reset (unlatch) when power is cycled.*

#### Non-Latching Relay (R<sub>u</sub>L<sub>o</sub>)

In this application, the meter is set up for automatic reset (non-latching relay). Acknowledging the alarm while it is still present has no effect on either the LED or the relay. When the alarm finally goes away, the relay automatically resets and the LED also goes off.

Automatic reset only		
Condition	LED	Relay
Normal	Off	Off
Alarm	On	On
Ack (No effect)	On	On
Normal	Off	Off

#### Non-Latching Relay (R<sub>n</sub>-n<sub>n</sub> R<sub>n</sub>)

In this application, the meter is set up for automatic and manual reset at any time (non-latching relay). The LED and the relay automatically reset when the meter returns to the normal condition.

The next time an alarm occurs, the operator acknowledges the alarm manually while the alarm condition still exists. This causes the relay to reset, but the LED stays on until the meter returns to the normal condition.

Automatic + manual reset at any time		
Condition	LED	Relay
Normal	Off	Off
Alarm	On	On
Normal	Off	Off
Next Alarm	On	On
Ack	On	Off
Normal	Off	Off

#### Latching Relay (L<sub>R</sub>L<sub>o</sub>H)

In this application, the meter is set up for manual reset at any time. Acknowledging the alarm even if the alarm condition is still present resets the relay and turns off the LED.

Manual reset any time		
Condition	LED	Relay
Normal	Off	Off
Alarm	On	On
Ack	Off	Off

#### Latching Relay (L<sub>L</sub>-L<sub>L</sub>r)

In this application, the meter is set up for manual reset only after the signal passes the reset point (alarm condition has cleared). Acknowledging the alarm while it is still present has no effect on either the LED or the relay. When the alarm is acknowledged after it returns to the normal state, the LED and the relay go off. Notice that the LED remains on, even after the meter returns to the normal condition. This is because, for latching relays, the alarm LED reflects the status of the relay, regardless of the alarm condition.

Manual reset only after alarm condition has cleared		
Condition	LED	Relay
Normal	Off	Off
Alarm	On	On
Ack (No effect)	On	On
Normal	On	On
Ack	Off	Off

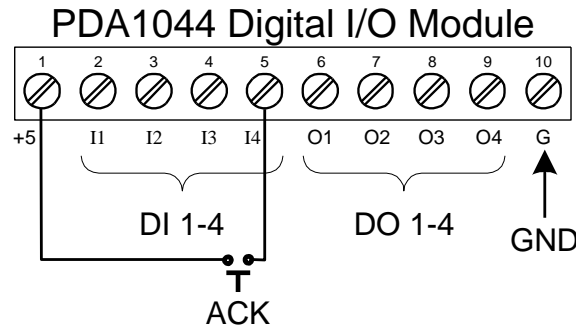
### Acknowledging Relays

There are two ways to acknowledge relays programmed for manual reset:

1. Via the programmable front panel function keys F1-F3 (Assignable via the *User* menu inside the *Advanced Features* menu).
2. Remotely via a normally open pushbutton wired across one of the digital inputs and the +5 V terminals on the digital I/O modules, or using the F4 digital input (factory default setting), which is triggered with a contact closure to COM, or with an active low signal (see page 22).

When the ACK button or the assigned digital input is closed, all relays programmed for manual reset are acknowledged.

*Note: The function key and digital input assignment is changed in the **Advanced – User** menu.*



**Figure 21. Acknowledge Relays with Digital Input**

### Pump Alternation Control Applications (RLLErn)

For pump control applications where two or more similar pumps are used to control the level of a tank, it is desirable to have all the pumps operate alternately. This prevents excessive wear and overheating of one pump over the lack of use of the other pumps.

Up to 4 relays can be set up to alternate every time an on/off pump cycle is completed. The set points and reset points can be programmed, so that the first pump on is the first pump off.

#### Application #1: Pump Alternation Using Relays 1 & 2

1. Relays 1 and 2 are set up for pump alternation.
2. Relays 3 and 4 are set up for low and high alarm indication.

Set and Reset Point Programming			
Relay	Set Point	Reset Point	Function
1	30.000	10.000	Controls pump #1
2	35.000	5.000	Controls pump #2
3	4.000	9.000	Controls low alarm
4	40.000	29.000	Controls high alarm

#### Pump Alternation Operation

1. Pump #1 turns on when level reaches 30.000, when level drops below 10.000 pump #1 turns off.
2. The next time level reaches 30.000, pump #2 turns on, when level drops below 10.000 pump #2 turns off.
3. If the level doesn't reach 35.000 pump #1 and pump #2 will be operating alternately.
4. If pump #1 cannot keep the level below 35.000 pump #2 will turn on at 35.000, then as the level drops to 10.000 pump #1 turns off, pump #2 is still running and shuts off below 5.000.
5. Notice that with the set and reset points of pump #2 outside the range of pump #1, the first pump on is the first pump to go off. This is true for up to 4 alternating pumps, if setup accordingly.
6. Relay #3 will go into alarm if the level drops below 4.000 and relay #4 will go into alarm if the level exceeds 40.000.

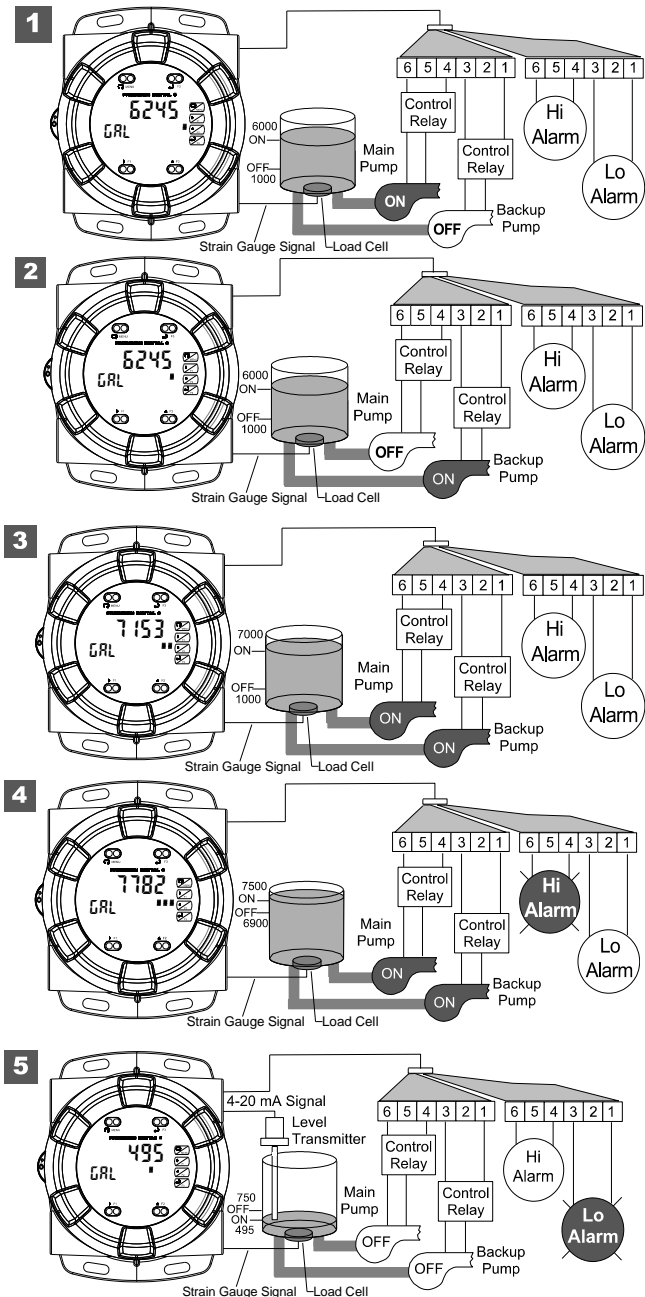
**Application #2: Pump Alternation Using Relays 3 & 4**

1. Relays 1 and 2 are set up for low and high alarm indication.
2. Relays 3 and 4 are set up for pump alternation.

Set and Reset Point Programming			
Relay	Set Point	Reset Point	Function
1	495	750	Controls low alarm
2	7500	6900	Controls high alarm
3	7000	900	Controls backup pump
4	6000	1000	Controls main pump

The following graphics provide a visual representation of a typical pump alternation application with high and low alarm monitoring.

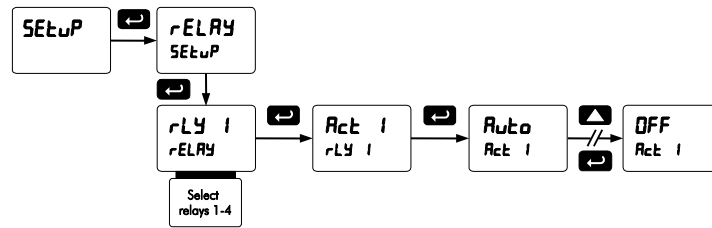
1. Relay #4 turns the main pump on at 6000 gallons and turns it off at 1000 gallons.
2. With the Pump Alternation feature activated, the next time the level reaches 6000 gallons, relay #3 transfers and starts the backup pump.
3. If the backup pump is not able to keep up, and the level reaches 7000 gallons, relay #4 transfers and starts the main pump as well.
4. Relay #2 trips the High Level Alarm at 7500 gallons and resets at 6900 gallons.
5. Relay #1 trips the Low Level Alarm at 495 gallons and resets at 750 gallons.



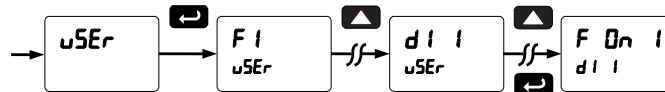
### Setting Up the Interlock Relay (Force On) Feature

Relays 1-4 can be set up as interlock relays. To set up the relays for the interlock feature:

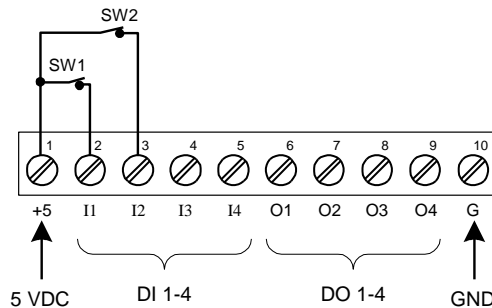
1. Access the *Setup – Relay – Action* menu and set the action to off.



2. In the Advanced features – *User* menu program any of the digital inputs to *Force On* any of the internal relays (1-4).



3. Connect a switch or dry contact between the +5V terminal and the corresponding digital input (dI-1 to dI-4) terminal.



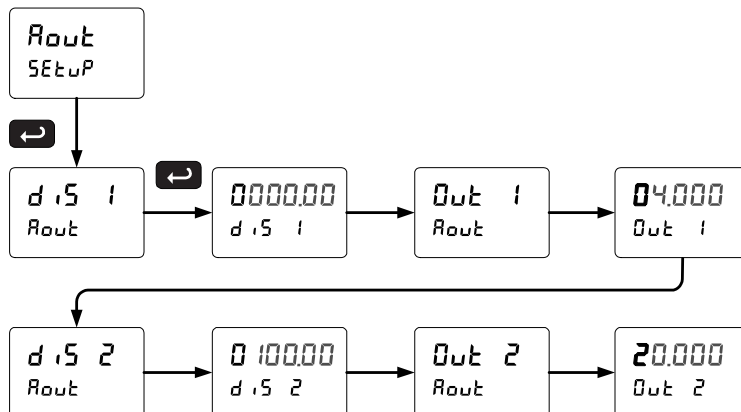
### Interlock Relay Operation Example

Relays 1 & 2 are configured to energize (their front panel LEDs are off) when SW1 & SW2 switches (above) are closed. If the contacts to these digital inputs are opened, the corresponding front panel LEDs flash indicating this condition. The processes being controlled by the interlock relay will stop, and will restart only after the interlock relay is re-activated by the digital inputs (switches).

### Scaling the 4-20 mA Analog Output (Rout)

The 4-20 mA analog output can be scaled to provide a 4-20 mA signal for any display range selected. No equipment is needed to scale the analog output; simply program the display values to the corresponding mA output signal.

The *Analog Output* menu is used to program the 4-20 mA output based on display values.



For instructions on how to program numeric values see *Setting Numeric Values*, page 29.

## Setting Up the Password (PASS)

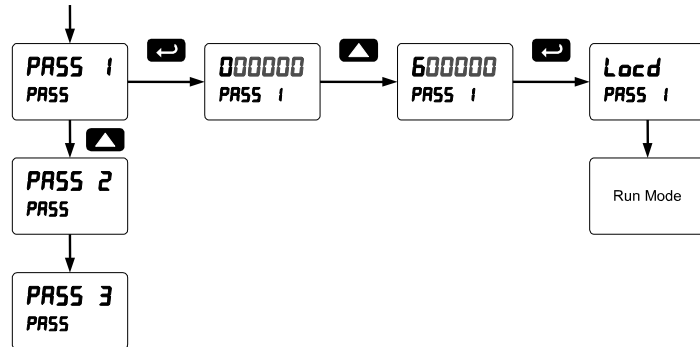
The *Password* menu is used for programming three levels of security to prevent unauthorized changes to the programmed parameter settings.

Pass 1: Allows use of function keys and digital inputs  
 Pass 2: Allows use of function keys, digital inputs and editing set/reset points  
 Pass 3: Restricts all programming, function keys, and digital inputs.

### Protecting or Locking the Meter

Enter the *Password* menu and program a six-digit password.

For instructions on how to program numeric values see Setting Numeric Values, page 29.

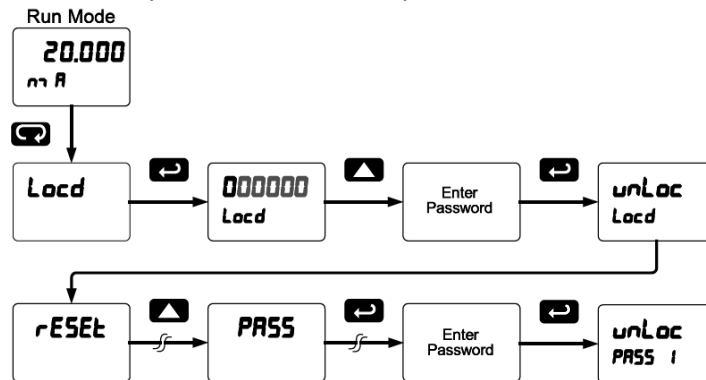


### Making Changes to a Password Protected Meter

If the meter is password protected, the meter will display the message *Locd* (Locked) when the Menu button is pressed. Press the Enter button while the message is being displayed and enter the correct password to gain access to the menu. After exiting the programming mode, the meter returns to its password protected condition.

### Disabling Password Protection

To disable the password protection, access the *Password* menu and enter the correct password twice, as shown below. The meter is now unprotected until a new password is entered.



If the correct six-digit password is entered, the meter displays the message *unLoc* (unlocked) and the protection is disabled until a new password is programmed.

If the password entered is incorrect, the meter displays the message *Locd* (Locked) for about two seconds, and then it returns to Run Mode. To try again, press Enter while the *Locked* message is displayed.

#### Did you forget the password?

The password may be disabled by entering a master password once. If you are authorized to make changes, enter the master password 508655 to unlock the meter.

### Reset Menu (rESEt)

The *Reset* menu is used to reset the tare (rSEt tR) and the maximum or minimum readings (peak or valley) reached by the process; max & min may be reset at the same time by selecting “reset high & low” (rSEt HL).

Note: Resetting the tare resets the max & min readings.

### Tare Menu (tRrE)

The *Tare* menu is used to select the tare mode. There are three modes of operation: *Capture Tare*, *Programmable Tare*, and *Off*.

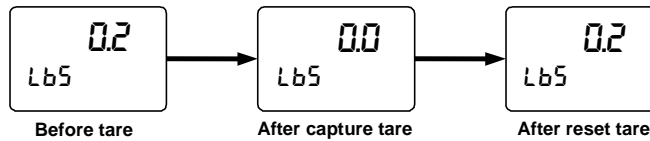
**Capture Tare:** Pressing the Tare key zeroes the display and the “T” indicator flashes indicating that tare is applied to the reading (e.g. Net weight).

**Programmable Tare:** Program a known value to be subtracted from the display value to obtain the net value. Pressing Reset tare clears the tare value to zero. Programmable Tare will not tare negative PVs. Use Capture Tare for negative PVs.

**Off:** Tare function is disabled and pressing Tare key has no effect.

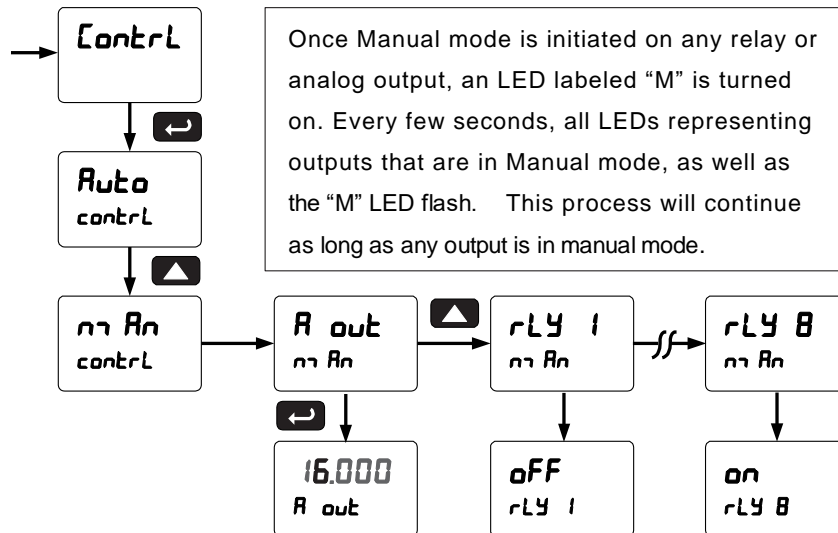
#### Tare Functionality (tRrE)

The tare function zeroes out the display. In the case of scale weight, tare is used to eliminate container weight and provide net weight readings.



### Control Menu (ContrL)

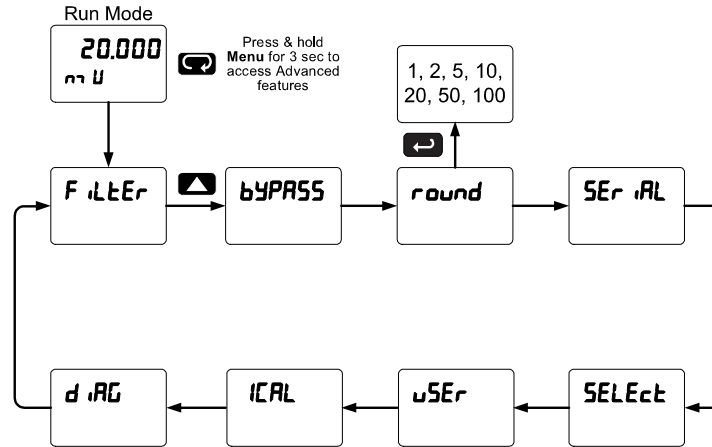
The *Control* menu is used to control the 4-20 mA analog output and the relays manually, ignoring the input. Each relay and analog output can be programmed independently for manual control. Selecting automatic control sets all relays and analog output for automatic operation.



## Advanced Features Menu

To simplify the setup process, functions not needed for most applications are located in the *Advanced Features* menu.

Press and hold the Menu button for three seconds to access the advanced features of the meter.



## Advanced Features Menu & Display Messages

The following table shows the functions and messages of the *Advanced Features* menu in the order they appear in the menu.

Display	Parameter	Action/Setting
F ILtEr	Filter	Set noise filter value
bYPASS	Bypass	Set filter bypass value
r ound	Rounding	Select rounding value
SErIAL	Serial	Set serial communication parameters
SlAVE ID	Slave ID	Set slave ID or meter address
bAUD	Baud rate	Select baud rate
t r dLY	Transmit delay	Set transmit delay for serial communication
PRr iLY	Parity	Select parity Even, Odd, or None with 1 or 2 stop bits
t -bYt	Time byte	Set byte-to-byte timeout
SELEct	Select	Enter the Select menu (function, cutoff, out)
FunctiOn	Signal input conditioning	Linear, select number of points
L inEAR	Linear	Set meter for linear function and select number of linearization points
Pu 1	PV1	Select PV1 number of linearization points
Pu 2	PV2	Select PV2 number of linearization points
no Pts	Number of points	Set PV1 for 2 to 32-point linearization Set PV2 for 2 to 8-point linearization

Display	Parameter	Action/Setting
SCALe	Scale	Scaling parameter
SCAL 1	Scale 1	Scaling parameter 1
SCAL 2	Scale 2	Scaling parameter 2
CutoffF	Cutoff	Set low cutoff
Auto 0	Auto Zero	Enter the Auto Zero function (on/off)
RoutePr	Analog output programming	Program analog output parameters
Source	Source	Select source for the 4-20 mA output
OverRNG	Overrange	Program mA output for display overrange
UnderrNG	Underrange	Program mA output for display underrange
MAX	Maximum	Program maximum mA output allowed
MIN	Minimum	Program minimum mA output allowed
CALIB	Calibrate	Calibrate 4-20 mA output (internal reference source used for scaling the output)
4 mA	4 mA output	Enter mA output value read by milliamp meter with at least 0.001 mA resolution
20 mA	20 mA output	Enter mA output value read by milliamp meter with at least 0.001 mA resolution

Display	Parameter	Action/Setting
ⓂⓈⓇ	User I/O	Assign function keys and digital I/O
F 1	F1 function key	Assign F1 function key (*F1/F2/F3)
F 4	F4 function	Assign F4 function (digital input)
ד 1 1	Digital input 1	Assign digital input 1 – 4
ד 0 1	Digital output 1	Assign digital output 1 – 4
ⓂⓈⓇ	Internal source calibration	Enter internal source calibration (used for scaling the meter without a signal source)
15 mV calibration	15 mV calibration	Calibrate 15 mV input range (internal reference source used for scaling the input)
20 mV calibration	20 mV calibration	Calibrate 30 mV input range (internal reference source used for scaling the input)

Display	Parameter	Action/Setting
100 mV calibration	100 mV calibration	Calibrate 150 mV input range (internal reference source used for scaling the input)
200 mV calibration	200 mV calibration	Calibrate 300 mV input range (internal reference source used for scaling the input)
Strain offset	Strain offset	Calibrate the offset of the input circuit
mV low	mV low	Calibrate low mV input (e.g. 0 mV)
mV high	mV high	Calibrate high mV input (e.g. 100 mV)
Diagnostics	Diagnostics	Display parameter settings
LED test	LED test	Test all LEDs
Information	Information	Display software and S/N information
Erase	Erase	Erase MeterView Pro software stored in meter's memory

### Noise Filter (F לָעֵר)

The noise filter is available for unusually noisy signals that cause an unstable process variable display. The noise filter averages the input signal over a certain period. The filter level determines the length of time over which the signal is averaged. The filter level can be set between 2 and 199. The higher the filter level, the longer the averaging time and so the longer it takes the display to settle to its final value. Setting the filter level to zero disables the filter function.

### Noise Filter Bypass (bYPASS)

The noise filter bypass changes the behavior of the meter so that small variations in the signal are filtered out but large abrupt changes in the input signal are displayed immediately. The bypass value determines the minimum amount of signal change to be displayed immediately. All signal changes smaller than the bypass value are filtered or averaged by the meter. The noise filter bypass may be set between 0.1 and 99.9% of full scale.

### Rounding Feature (round)

The rounding feature is used to give the user a steadier display with fluctuating signals. Rounding is used in addition to the filter function.

Rounding causes the display to round to the nearest value according to the rounding selected. This setting affects the last two digits, regardless of decimal point position. See examples below:


Rounding Selection	Actual Value	Display Value	Actual Value	Display Value
1	12.022	12.022	12.023	12.023
5	12.022	12.020	12.023	12.025
10	12.024	12.020	12.025	12.030



## Modbus RTU Serial Communications (SERIAL)

The meter is equipped with serial communications capability as a standard feature using Modbus RTU Serial Communication Protocol.

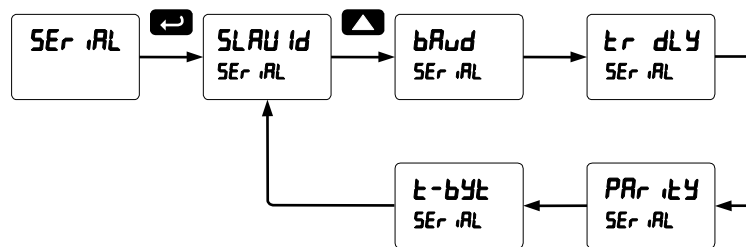
The meter may be connected to a PC for initial configuration via the onboard micro USB connection. For ongoing digital communications with a computer or other data terminal equipment, an RS-232, or RS-485 option is required; see *Ordering Information* on page 5 for details.



**Warning!** *Do not connect any equipment other than Precision Digital's expansion modules, cables, or meters to the RJ45 M-LINK connector. Otherwise damage will occur to the equipment and the meter.*

*Note: More detailed instructions are provided with each optional serial communications adapter.*

*Note: Refer to the ProVu® Modbus Register Tables located at [www.predig.com](http://www.predig.com) for details.*



When using more than one meter in a multi-drop mode, each meter must be provided with its own unique address. The meter address (Slave ID) may be programmed between 1 and 247. The transmit delay may be set between 0 and 199 ms. The parity can be set to even, odd, or none with 1 or 2 stop bits.

## Serial Communications Overview

RS-232 and RS-485 are standard interfaces approved by the Electronic Industries Alliance (EIA) for connecting serial devices. In EIA terms, the device (e.g. meter) that connects to the interface is called a Data Communications Equipment (DCE) and the device to which it connects (e.g. the computer) is called a Data Terminal Equipment (DTE).

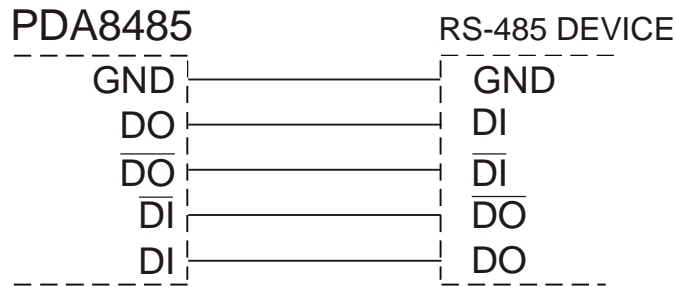
RS-485 can support multi-point connections per line because it uses lower-impedance drivers and receivers.

Line drivers and receivers are used to exchange data between two or more points (nodes) on a serial communications network. Reliable data communications can be difficult in the presence of induced noise, ground level differences, and other hazards associated with installation of a network. When communicating at high data rates, or over long distances in real world environments, RS-232 is often inadequate. The differential data transmission of RS-485 offers superior performance in most applications. Differential signals can help nullify the effects of ground shifts and induced noise signals that can appear as common mode voltages on a network.

A multi-point network consists of multiple drivers and receivers connected on a single bus, where any point (node) can transmit and/or receive data. RS-485 allows multiple drivers and receivers on the same two-wire or four-wire system. The RS-485 standard specifies up to 32 drivers and 32 receivers on a single bus, but with the introduction of "automatic" repeaters and high-impedance drivers/receivers, this number can be extended to hundreds of points (nodes) on a network.

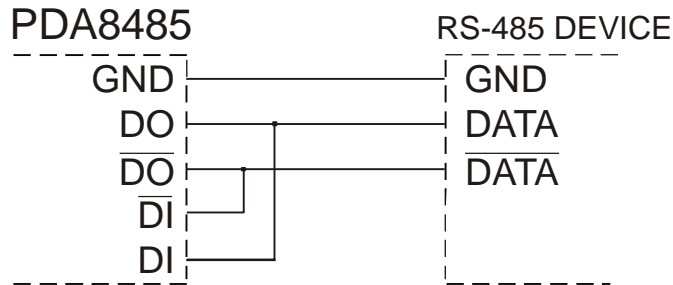
The cabling used for an RS-485 serial communications network should always be a high quality cable such as Belden 8162 or Alpha 6203C. A two-wire system requires two twisted pairs, and a four-wire system requires three twisted pairs (the extra twisted pair is needed for the signal ground).

Figure 22 illustrates how to connect a general four-wire network (a four-wire network actually contains 5 wires).



**Figure 22: General Four-Wire Network Connection**

Figure 23 illustrates how to connect a general two-wire network (a two-wire network actually contains 3 wires). Note that the PDA7485 and PDA8485 have DIP switches that allow for two-wire connections without the need to externally wire the DO to the DI and the  $\overline{DO}$  to the  $\overline{DI}$  (see the converter section for complete details).

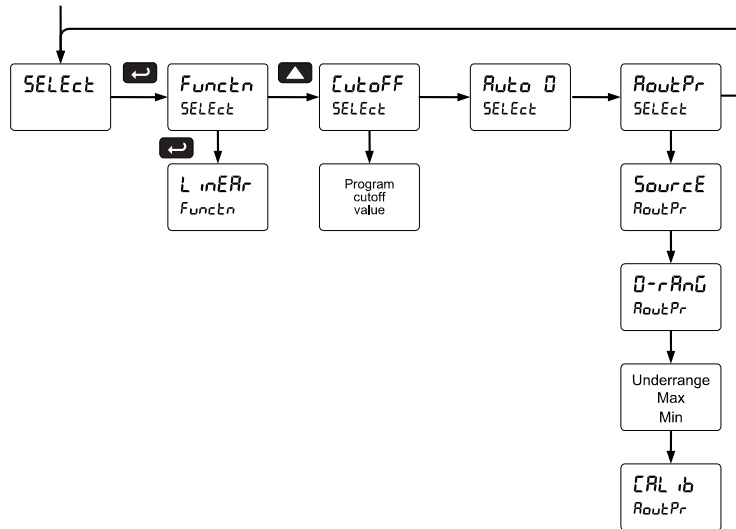


**Figure 23: General Two-Wire Network Connection**

### Select Menu (SELEct)

The *Select* menu is used to select the signal input conditioner applied to the input (linear), low cutoff, Auto-zero, and analog output programming.

The multi-point linearization is part of the linear function selection.



### Signal Input Conditioning (Functn)

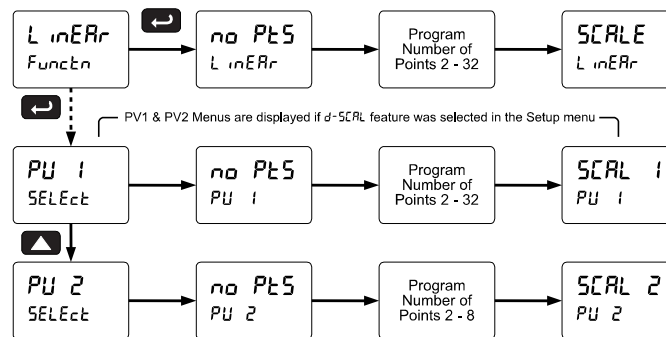
The *Function* menu is used to select the signal input conditioner applied to the input: linear. The multi-point linearization is part of the linear function selection.

Meters are set up at the factory for linear function with 2-point linearization. The linear function provides a display that is linear with respect to the input signal.

#### Multi-Point Linearization (L inERr)

Meters are set up at the factory for linear function with 2-point linearization. Up to 32 linearization points can be selected for PV under the linear function. The multi-point linearization can be used to linearize the display for non-linear signals such as those from level Sensors used to measure volume in odd-shaped tanks or to convert level to flow using weirs and flumes with complex exponent.

If the dual-scale Level feature has been selected, the menus for PV1 & PV2 are enabled. PV2 can be programmed with up to 8 linearization points.



### Auto-Zero (Auto 0)

Auto-zero corrects for drift that can occur over time that causes the input signal to slowly change. The meter will continue to read zero despite slow and small changes to the input signal. The auto-zero value represents the percent of full scale drift that the meter will correct.

Under normal circumstances, when the signal increases quickly, by an amount greater than the auto-zero percent of full scale, the value will not be adjusted for. Slow signal changes that occur over time at increments less than the auto-zero value, will not register on the meter (example: dust on a load cell or sensor drift over time).

### Low Cutoff (Cutoff)

The low cutoff feature allows the meter to be programmed so that the often-unsteady output from a differential pressure Sensor, at low rates, always displays zero on the meter.

The cutoff value may be programmed from 0 to 999999. The meter will display zero below the cutoff value. Programming the cutoff value to zero disables the cutoff feature.

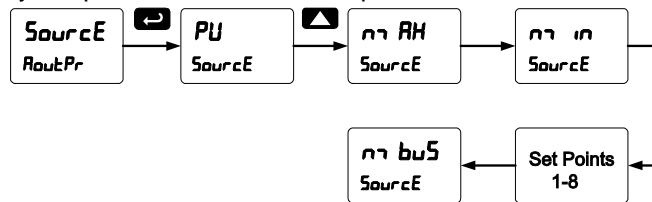
### Analog Output Programming (RoutPr)

The *Analog Output Programming* menu is used to program the behavior of the 4-20 mA output. The following parameters and functions are programmed in this menu:

1. Source: Source for generating the 4-20 mA output (e.g. PV)
2. Overrange: Analog output value with display in overrange condition
3. Underrange: Analog output value with display in underrange condition
4. Max: Maximum analog output value allowed regardless of input
5. Min: Minimum analog output value allowed regardless of input
6. Calibrate: Calibrate the internal 4-20 mA source reference used to scale the 4-20 mA output

### Analog Output Source

The source for generating the 4-20 mA output may be assigned to the process variable, maximum or minimum value reached by the process, one of the set points, or the Modbus PV input.



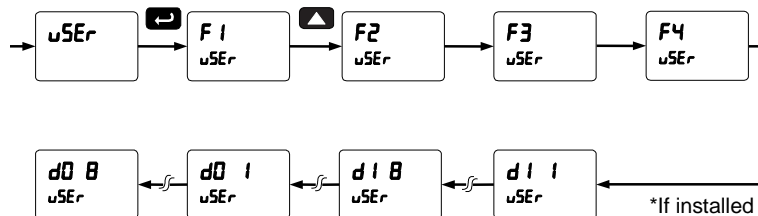
### Analog Output Calibration

To perform the analog output calibration, it is recommended to use a milliamp meter with a resolution of at least 0.1  $\mu$ A to measure the output current. The values saved internally during this procedure are used for scaling the 4-20 mA output in the *Setup* menu.

### Programmable Function Keys User Menu (uSEr)

The *User* menu allows the user to assign the front panel function keys F1, F2, and F3, the digital input F4 (a digital input located on the signal input connector), and up to eight additional digital inputs to access most of the menus or to activate certain functions immediately (e.g. reset max & min, hold relay states, etc.). This allows the meter to be greatly customized for use in specialized applications.

Up to eight digital outputs can be assigned to a number of actions and functions executed by the meter (i.e. alarms, relay acknowledgement, reset max, min, or max & min, tare, and reset tare). The digital outputs can be used to trigger external alarms or lights to indicate these specific events.



### Function Keys & Digital I/O Available Settings

Refer to the following table for descriptions of each available function key or digital I/O setting.

Display	Description	Display	Description
r5t H1	Reset the stored maximum display value	Ln2 H1	Display maximum display value on line 2
r5t L0	Reset the stored minimum display value	Ln2 L0	Display minimum display value on line 2
r5t HL	Reset the stored maximum & minimum display values	Ln2 HL	Display maximum & minimum display values on line 2
tRrE	Capture tare and zero the display	zEr0	Zero the display (this is different from <i>capture tare</i> because it cannot be reset)
r5t tr	Reset captured tare and resume normal operation	F 0n 1*	Force relay 1 (*through 4) into the on state. This function is used in conjunction with a digital input to achieve interlock functionality. See page 46 for details about interlock relays.
rELRY	Directly access the relay menu	Control	Directly access the control menu
5Et 1*	Directly access the set point menu for relay 1 (*through 8)	d,5RbL	Disable the selected function key or digital I/O
rLY d	Disable all relays until a button assigned to <i>enable relays (rLY E)</i> is pressed	RcH	Acknowledge all active relays that are in a manual operation mode such as auto-manual or latching
rLY E	Enable all relays to function as they have been programmed	rE5Et	Directly access the reset menu
0 Hold	Hold current relay states as they are until a button assigned to <i>enable relays (rLY E)</i> is pressed	nEnu	Mimic the menu button functionality (digital inputs only)
d Hold	Hold the current display value momentarily while the function key or digital input is active. The process value will continue to be calculated in the background.	r,5Ht	Mimic the right arrow/F1 button functionality (digital inputs only)
Ln1 H1	Display maximum display value on line 1	uP	Mimic the up arrow/F2 button functionality (digital inputs only)
Ln1 L0	Display minimum display value on line 1	EntEr	Mimic the enter/F3 button functionality (digital inputs only)
Ln1 HL	Display maximum & minimum display values on line 1	RLn1 1*	Provide indication when alarm 1 (*through 8) has been triggered (digital outputs only)
Ln2nV	Display the mV input on line 2		

## Internal Source Calibration (ICAL)

The meter is factory calibrated prior to shipment to read in millivolts. The calibration equipment is traceable to NIST standards. There is no need to perform an internal calibration for new meter.

The internal source allows the user to scale the meter without applying a signal.

The use of calibrated signal sources is necessary to perform the internal source calibration of the meter.

Check calibration of the meter at least every 12 months. Each range must be recalibrated separately.

**Notes:**

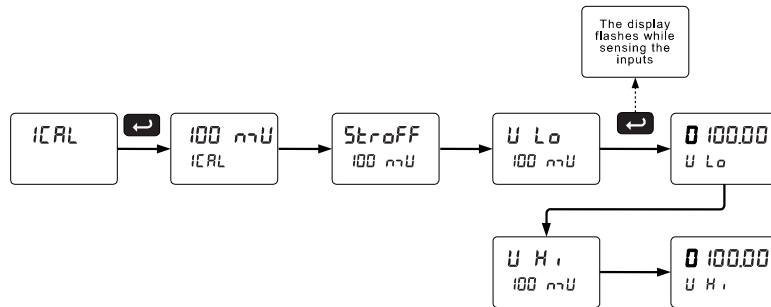
1. *mV input: If meter is in operation and it is intended to accept only one input range (e.g. 0-30 mV), recalibration of other ranges is not necessary.*
2. *Strain gauge: If the meter is intended to accept a strain gauge bridge input, it is recommended to use the CAL function with ratiometric compensation turned on.*
3. *Allow the meter to warm up for at least 15 minutes before performing the internal source calibration procedure.*

The *Internal calibration* menu is part of the *Advanced Features* menu.

1. Press and hold the Menu button for three seconds to access the advanced features of the meter.
2. Press the Up arrow button to scroll to the *Internal calibration* menu (ICAL) and press Enter.
3. The meter displays the first input range (15 mV), press the Up arrow to select any other range (e.g. 100 mV). Press Enter to start the calibration process.

**Example of Internal Calibration for 100 mV input range:**

4. The meter displays the message "STROFF" (strain offset), short the SG+, SG- terminals and press Enter. The *low* input message is displayed (U Lo). Apply the low input signal (e.g. 0.00 mV) and press Enter. The display flashes for a moment while the meter is accepting the low input signal.
5. After the display stops flashing, a number is displayed with the leftmost digit brighter than the rest. The bright digit is the active digit that can be changed by pressing the Up arrow button. Press the Right arrow button to move to the next digit.
6. Set the display value to correspond to the input signal being calibrated; typically 0.00 mV.
7. The display moves to the *high* input calibration (U Hi). Apply the high input signal and press Enter.
8. Set the display for the high input calibration, in the same way as it was set for the low input calibration, typically 100.00 mV.



The graphic above shows the calibration of the 100 mV input range. The other input ranges are calibrated in a similar way.

**Tips:**

- Low and high input signals can be any valid values within the range of the meter.
- Observe minimum input span requirements between input 1 and input 2.
- Low input should be less than high input signal.

### Error Message (*Error*)

An error message indicates that the calibration or scaling process was not successful.

After the error message is displayed, the meter reverts to input 2 during calibration or scaling and to input 1 during internal calibration, allowing the appropriate input signal to be applied or programmed.

The error message might be caused by any of the following conditions:

1. Input signal is not connected to the proper terminals, or it is connected backwards.
2. Wrong signal selection in *Setup* menu.
3. Minimum input span requirements not maintained.

### Minimum Input Span

The minimum input span is the minimum difference between input 1 and input 2 signals required to complete the calibration or scaling of the meter.

Input Range	Input 1 & Input 2 Span
15 mV	0.2 mV
25 mV, 30 mV	0.4 mV
150 mV	2.0 mV
250 mV, 300 mV	4.0 mV









## Meter Operation

The meter is capable of accepting any signal from -250 to 250 mV in bipolar mode, or 0 to 300 mV in unipolar mode, and displaying these signals in engineering units from -99999 to 999999 (e.g. a 0-100 mV signal could be displayed as 0 to 50000). The dual-line display can be customized by the user to operate in such a way as to satisfy a specific application. Typically, display line 1 is used for the process variable; while line 2 is used for engineering units, custom legend, or set point indication.

The input signal can be scaled to display the process in two different scales; for example, line 1 could indicate weight in pounds and line 2 could indicate percent of maximum weight capacity. The meter can also be set up to display the analog input on line 1 and the Modbus input on line 2. The relays and analog output can be programmed to operate from the Modbus PV input if the Modbus input has been assigned to display line 1.

During operation, the meter can be either tared or zeroed. The tare feature is useful for momentarily zeroing out of the display, in the case where there is additional weight than what is intended to be measured (e.g. a bucket on the scale is being filled with material). The meter will display a T to indicate that the display has been tared and taring is resettable via the reset tare operation. The zero feature is useful for permanent zeroing of the meter, in the case where there has been drift in the strain gauge output over time. The zero feature will zero out the display without indication or the ability to reset.

## Front Buttons Operation

Button	Description
 	Press to enter or exit <i>Programming Mode</i> .
 	Press to zero the meter or other parameter/ function assigned through the <i>User</i> menu.
 	Press to reset tare or other parameter/function assigned through the <i>User</i> menu.
 	Press to tare the display value or other parameters/function assigned through the <i>User</i> menu.

## SafeTouch® Buttons

The ProtEX-MAX is equipped with four sensors that operate as through-glass buttons so that it can be programmed and operated without removing the cover (and exposing the electronics) in a hazardous area.

These buttons can be disabled for security by selecting DISABLE on the switch labeled NO-CONTACT BUTTONS located on the connector board.

To actuate a button, press one finger to the glass directly over the marked button area. Then retract finger more than three inches from the glass before pressing the next button. When the cover is removed, the four mechanical buttons located next to the sensors are used. The sensors are disabled when a mechanical button is pressed and will automatically be re-enabled after 60 seconds of inactivity.


The SafeTouch Buttons are designed to filter normal levels of ambient interference and to protect against false triggering, however, it is recommended that the SafeTouch Buttons be disabled (slide switch to LOCK) if there is an infrared interference source in line-of-sight to the display.

The SafeTouch Buttons are configured by default to duplicate the function of the front panel mechanical pushbuttons associated with the integrated meter. The symbols by each SafeTouch button correspond to a mechanical button as shown in the above table.



SafeTouch Button Tips:

- To the extent possible, install the display facing away from sunlight, windows, reflective objects and any sources of infrared interference.
- Keep the glass window clean.
- Tighten the cover securely.
- Use a password to prevent tampering.



**WARNING** Take caution when cleaning the window glass as it may result in unintentional SafeTouch button events. Only clean the ProtEX-MAX when the system is safely shut down, and inspect the ProtEX-MAX for proper configuration prior to system restart.

### Function Keys Operation

During operation, the programmable function keys operate according to the way they have been programmed in the *Advanced Features – User* menu.

The table above shows the factory default settings for F1, F2, and F3.

### Maximum/Minimum Readings

The max & min readings (peak & valley) reached by the process can be displayed either continuously or momentary:

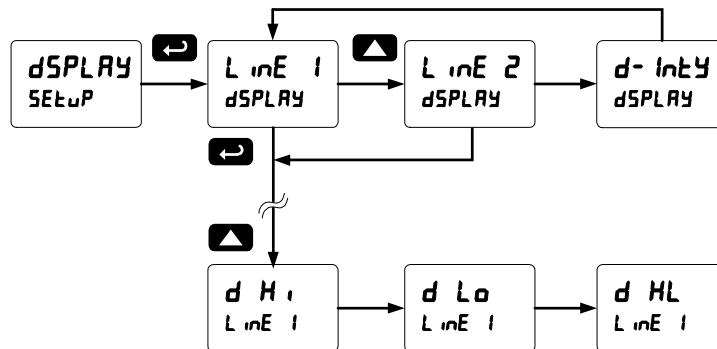
1. Display briefly by assigning to the F1-F3 function keys or to the digital inputs in the *User* menu. Any of the F1-F3 function keys (buttons) and the digital inputs can be programmed to reset the max & min readings.
2. Display continuously by assigning either display to max/min through the *Display* menu.

**To display max reading using function key:**

1. Press user assigned function key/digital input to display maximum reading since the last reset/power-up.
2. To reset max/min, press the Menu button, then the Up arrow/F2 button until the Reset (rESEt) menu is displayed.
3. Press the Up arrow/F2 button to select reset high (rSE H i), reset low (rSE Lo), or reset high and low (rSE HL) is displayed and then press the Enter/F3 button. The max and/or min displays are reset to actual values.
4. Press Menu to exit max/min display reading.

**To display max/min readings continuously:**

Assign either display to Max (d H i), Min (d Lo), or toggle between Max and Min (d HL) every 10 seconds.



## Troubleshooting

Due to the many features and functions of the meter, it's possible that the setup of the meter does not agree with what an operator expects to see. If the meter is not working as expected, refer to the *Diagnostics* menu and consult the recommendations described below.

### Diagnostics Menu (d ,RG)

The *Diagnostics* menu is located in the *Advanced Features* menu, to access *Diagnostics* menu see *Advanced Features Menu*, page 49.

This menu allows the user to test the functionality of all the meter LEDs, check the meter's software and version information, and erase the MeterView Pro software installation files from the meter. Press the Enter button to view the settings and the Menu button to exit at any time.

For a description of the diagnostic messages, see *Advanced Features Menu & Display Messages*, page 49.

### Determining Software Version

To determine the software version of a meter:

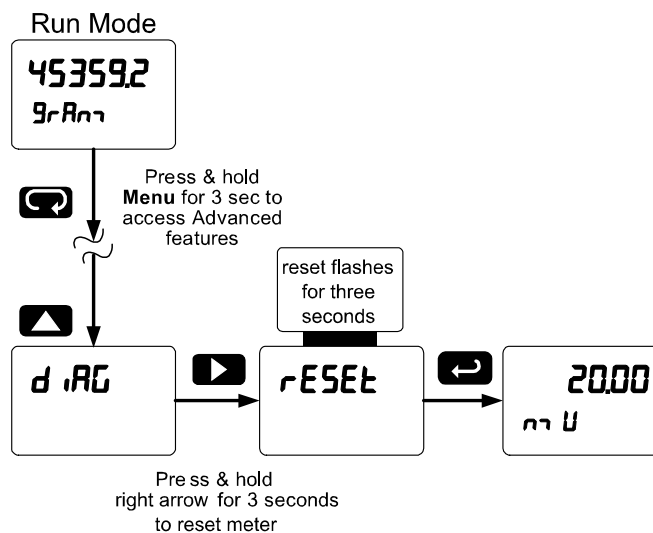
1. Go to the *Diagnostics* menu (d ,RG) and press Enter button.
2. Press Up arrow button and scroll to Information menu ( InF0).
3. Press Enter to access the software number (5Ft) and version (UEr) information. Write down the information as it is displayed. Continue pressing Enter until all the information is displayed.
4. The meter returns to Run Mode after displaying all the settings.

### Reset Meter to Factory Defaults

When the parameters have been changed in a way that is difficult to determine what's happening, it might be better to start the setup process from the factory defaults.

#### Instructions to load factory defaults:

1. Enter the *Advanced Features* menu. See *Advanced Features Menu*, page 49.
2. Press Up arrow to go to *Diagnostics* menu
3. Press and hold Right arrow for three seconds, press Enter when display flashes rESEt.  
Note: If Enter is not pressed within three seconds, the display returns to the *Diagnostics* menu.
4. The meter goes through an initialization sequence (similar as on power-up), and loads the factory default settings.



## Factory Defaults & User Settings

The following table shows the factory setting for most of the programmable parameters on the meter.

Parameter	Display	Default Setting	Parameter	Display	Default Setting
Input type	<i>PolAr</i>	Polar = Uni	Fail-safe relay 1	<i>FLS 1</i>	Off
Input Range	<i>rRnGE</i>	Range = 30mV	Fail-safe relay 2	<i>FLS 2</i>	Off
Ratiometric	<i>rRt io</i>	Ratio = Yes	Fail-safe relay 3	<i>FLS 3</i>	Off
Dual-scale	<i>d-ScAL</i>	No (Single scale)	Fail-safe relay 4	<i>FLS 4</i>	Off
Filter	<i>F iLEr</i>	70	On delay relay 1	<i>On 1</i>	0.0 sec
Bypass	<i>bYPASS</i>	0.2	Off delay relay 1	<i>OFF 1</i>	0.0 sec
Rounding	<i>round</i>	1	On delay relay 2	<i>On 2</i>	0.0 sec
Function	<i>Functn</i>	Linear	Off delay relay 2	<i>OFF 2</i>	0.0 sec
Number of points	<i>no Pts</i>	2	On delay relay 3	<i>On 3</i>	0.0 sec
Programming	<i>Prog</i>	Scale	Off delay relay 3	<i>OFF 3</i>	0.0 sec
Input 1	<i>inP 1</i>	0.00 mV	On delay relay 4	<i>On 4</i>	0.0 sec
Display 1	<i>d iS 1</i>	0.00	Off delay relay 4	<i>OFF 4</i>	0.0 sec
Input 2	<i>inP 2</i>	100.00 mV	Display 1 analog out	<i>d iS 1</i>	0.00
Display 2	<i>d iS 2</i>	100.00	Output 1 value	<i>Out 1</i>	4.000 mA
Decimal point	<i>ddddddd</i>	3 places	Display 2 analog out	<i>d iS 2</i>	100.00
Cutoff value	<i>CutOFF</i>	0.000 (disabled)	Output 2 value	<i>Out 2</i>	20.000 mA
Auto-zero	<i>Auto 0</i>	0.05% of Full Scale	Source analog output	<i>Source</i>	Process Variable
Display assignment	<i>dSPLY</i>		Overrange output	<i>0-rRnG</i>	21.000 mA
Line 1	<i>L inE 1</i>	PV: Process variable	Underrange output	<i>u-rRnG</i>	3.000 mA
Line 2	<i>L inE 2</i>	Eng units: mV	Maximum output	<i>max RH</i>	23.000 mA
Display intensity	<i>d-IntY</i>	8	Minimum output	<i>min in</i>	1.000 mA
Relay 1 action	<i>Rct 1</i>	Automatic	Slave ID (Address)	<i>SLAU id</i>	247
Relay 1 set point	<i>SEt 1</i>	10.00	Baud rate	<i>bAud</i>	9600
Relay 1 reset point	<i>rSEt 1</i>	5.00	Transmit delay	<i>tr dLY</i>	10 ms
Relay 2 action	<i>Rct 2</i>	Automatic	Parity	<i>PAR itY</i>	Even
Relay 2 set point	<i>SEt 2</i>	20.00	Byte-to-byte timeout	<i>b-byt</i>	010 (0.1 sec)
Relay 2 reset point	<i>rSEt 2</i>	15.00	F1 function key	<i>F 1</i>	Zero
Relay 3 action	<i>Rct 3</i>	Automatic	F2 function key	<i>F 2</i>	Reset Tare
Relay 3 set point	<i>SEt 3</i>	30.00	F3 function key	<i>F 3</i>	Tare
Relay 3 reset point	<i>rSEt 3</i>	25.00	F4 Function	<i>F 4</i>	Acknowledge relays
Relay 4 action	<i>Rct 4</i>	Automatic	Digital input 1	<i>d i 1</i>	Menu
Relay 4 set point	<i>SEt 4</i>	40.00	Digital input 2	<i>d i 2</i>	Right arrow/F1
Relay 4 reset point	<i>rSEt 4</i>	35.00	Digital input 3	<i>d i 3</i>	Up arrow/F2

Parameter	Display	Default Setting
Digital input 4	<i>dI 4</i>	Enter/F3
Digital output 1	<i>dO 1</i>	Alarm 1
Digital output 2	<i>dO 2</i>	Alarm 2
Digital output 3	<i>dO 3</i>	Alarm 3

Parameter	Display	Default Setting
Digital output 4	<i>dO 4</i>	Alarm 4
Password 1	<i>PASS 1</i>	000000 (unlocked)
Password 2	<i>PASS 2</i>	000000 (unlocked)
Password 3	<i>PASS 3</i>	000000 (unlocked)

**Troubleshooting Tips (Including FAULT & ERROR Messages)**

Symptom	Check/Action
SafeTouch buttons do not respond	If mechanical button was pushed. The SafeTouch buttons will be re-enabled automatically <b>60 seconds</b> after the last button push. If slide switch on connector board is in DISABLE position, switch to ENABLE. Strong direct sunlight may interfere with SafeTouch button operation. It is recommended to operate the buttons by standing so as to block direct sunlight.
Serial Communications Power LED Indicator is off	1. Check modular cable connection Check power to the device
If only the TX (or DATA IN) data status LED is flashing when serial communications attempted	1. Check serial cable 2. Check protocol selected on device 3. Check instrument address & baud rate Check program address & baud rate
If both data status LEDs (TX and RX) are off when trying to communicate	Remove all unnecessary cables and instruments from the bus. Try getting the system to work with only one device (to ease troubleshooting) and then expand the system one device at a time.
Communications slow	Increase the baud rate
Random communication errors	1. Increase the TX delay time Decrease the baud rate
Power LED is off	1. Check modular cable connection Check power to instrument
No display at all	Check power at power connector
Not able to change setup or programming, <i>Lcd</i> is displayed	Meter is password-protected, enter correct six-digit password to unlock
Meter displays error message during calibration ( <i>Error</i> )	Check: 1. Signal connections 2. Input selected in <i>Setup</i> menu 3. Minimum input span requirements
Meter displays 1. <i>999999</i> 2. <i>-999999</i> 3. <i>FAULT</i>	Check: 1. Input selected in <i>Setup</i> menu 2. Signal at Signal connector 3. Input exceeds range selected
Display is unstable	Check: 1. Input signal stability and value 2. Display scaling vs. input signal 3. Filter and bypass values (increase) 4. Increase Rounding value
Display response is too slow	Check filter and bypass values
Display reading is not accurate	Check: 1. Signal input conditioner selected: Linear, square root, etc. 2. Scaling or calibration
Display does not respond to input changes, reading a fixed number	Check: 1. Display assignment, it might be displaying max, min, or set point.

Symptom	Check/Action
Display alternates between 1. <i>H</i> and a number 2. <i>L</i> and a number	Press Menu to exit max/min display readings.
Relay operation is reversed	Check: 1. Fail-safe in <i>Setup</i> menu 2. Wiring of relay contacts
Relay and status LED do not respond to signal	Check: 1. Relay action in <i>Setup</i> menu 2. Set and reset points
Flashing relay status LEDs	Relays in manual control mode or relay interlock switches opened.
Meter not communicating with application programs	Check: 1. Serial adapter and cable 2. Serial settings 3. Meter address and baud rate
If the display locks up or the meter does not respond at all	Cycle the power to reboot the microprocessor.
Other symptoms not described above	Call Technical Support for assistance.

## Service



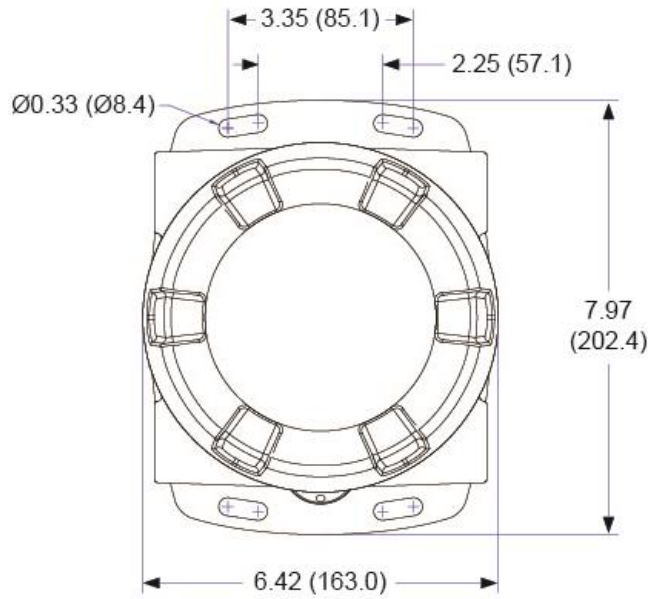
### WARNINGS

- Installation and service should be performed only by trained service personnel. Service requiring replacement of internal sub-components must be performed at the factory.
- Disconnect from supply before opening enclosure. Keep cover tight while circuits are alive. Conduit seals must be installed within 18" (450mm) of the enclosure.
- Verify that the operating atmosphere of the instrument is consistent with the appropriate hazardous locations certifications.
- If the instrument is installed in a high voltage environment and a fault or installation error occurs, high voltage may be present on any lead
- Read all product labels completely and follow all instructions and requirements listed on the labels for installation or service.

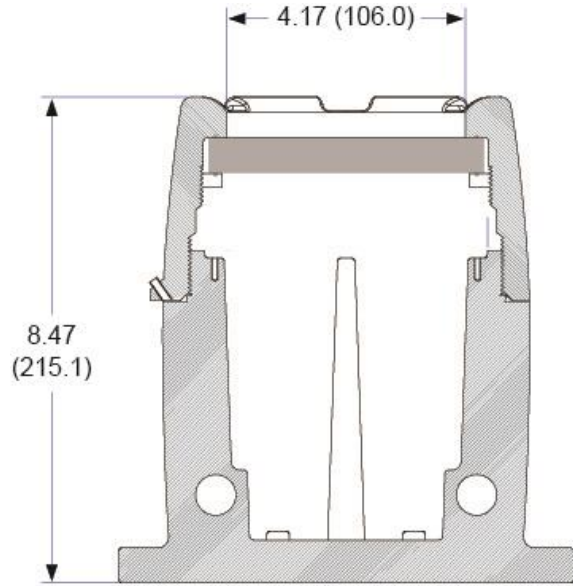
If the enclosure is sound and undamaged, then only the internal electronics housing will need to be returned to the factory for service. Contact the factory for RMA number and return instructions.

## Mounting Dimensions

All units: inches (mm)



**Figure 24: Enclosure Dimensions – Front View**



**Figure 25: Enclosure Dimensions – Side Cross Section View**

# EU Declaration of Conformity

Issued in accordance with ISO/IEC 17050-1:2004 and ATEX Directive 2014/34/EU.

We,

**Precision Digital Corporation**  
233 South Street  
Hopkinton, MA 01748 USA

as the manufacturer, declare under our sole responsibility that the product(s),

**Model PD8 ProtEX-MAX Series**

to which this declaration relates, is in conformity with the European Union Directives shown below:

<b>2014/35/EU</b>	<b>Low Voltage Directive</b>
<b>2014/34/EU</b>	<b>ATEX Directive</b>
<b>2014/30/EU</b>	<b>EMC Directive</b>
<b>2011/65/EU</b>	<b>RoHS Directive</b>

This conformity is based on compliance with the application of harmonized or applicable technical standards and, when applicable or required, a European Union notified body certification.

#### Standards:

EN 55022:2007	EN 61000-6-2:2005	EN 60079-0:2009	EN 61000-6-4:2007
EN 60079-1:2007	EN 61010-1:2001	EN 60079-31:2008	EN 61326:2006

The standards EN 55022:2007, EN 60079-0:2009, EN 60079-1:2007, EN 60079-31:2008, EN 61000-6-4:2007, EN 61010-1:2001, and EN 61326:2006 are no longer harmonized. The requirements of these standards have been checked against the harmonized standard EN 55022:2010, EN 60079-0:2012+A11:2013, EN 60079-1:2014, EN 60079-31:2014, EN 61000-6-4:2007+A1:2011, EN 61010-1:2010, and EN 61326:2013 and there were no major technical changes affecting the latest technical knowledge for the products listed above.

**EC Type Examination Certificate:** Sira 12ATEX1182

#### Product Markings:



II 2 G D  
Ex d IIC T\* Gb  
Ex tb IIIC T90°C Db IP68  
Tamb = -40°C to +\*°C (\*T5 = 65°C, \*T6 = 60°C)

**ATEX Notified Body for EC Type Examination Certificate:** Sira Certification Service, NB 0518  
Unit 6, Hawarden Industrial Park  
Hawarden, Deeside, CH5 3US, UK

**ATEX Quality Assurance Notification No.:** SIRA 10 ATEX M462

**ATEX Notified Body for Quality Assurance:** Sira Certification Service, NB 0518  
Unit 6, Hawarden Industrial Park  
Hawarden, Deeside, CH5 3US, UK

Signed for and on behalf of Precision Digital Corporation:

  
\_\_\_\_\_

Name: Jeffrey Peters  
Company: Precision Digital Corporation  
Title: President  
Date: 02/12/2018



Document No: DoC PD8 {021218}

## How to Contact Precision Digital

- For Technical Support please  
Call: (800) 610-5239 or (508) 655-7300  
Fax: (508) 655-8990  
Email: [support@predig.com](mailto:support@predig.com)
- For Sales Support or to place an order please contact your local distributor or

Order from: **C A Briggs Company**

622 Mary Street; Suite 101; Warminster, PA 18974

Phone: 267-673-8117 - Fax: 267-673-8118

[Sales@cabriggs.com](mailto:Sales@cabriggs.com) - [www.cabriggs.com](http://www.cabriggs.com)

- For the latest version of this manual please visit  
[www.predig.com](http://www.predig.com)

### PRECISION DIGITAL CORPORATION

233 South Street • Hopkinton MA 01748 USA  
Tel (800) 343-1001 • Fax (508) 655-8990



[www.predig.com](http://www.predig.com)