

PROVU PD6262 Dual Analog Input Rate/Totalizer Instruction Manual



PROVU[®]
SERIES



Rate/Totalizer

- Two (2) 0-20 mA, 4-20 mA, 0-5 V, 1-5 V, and ± 10 V Inputs
- Displays Two Flow Inputs Simultaneously
- Displays Rate and Total Simultaneously
- Math Functions Capabilities
- Isolated 24 VDC @ 200 mA Transmitter Power Supply
- Count Up or Down, Total & Grand Total
- Open Channel Flow with Programmable Exponent
- Non-Resettable Grand Total
- 32-Point Linearization
- Dual-Line Display
- NEMA 4X and IP65 Rated Front Panel
- UL Listed & CE Marked
- Display Features 0.6" & 0.46" Digits
- Six Full Digits on Each Line
- Optional Superluminous Sunlight Readable Display
- Free USB Programming Software & Cable
- 2 or 4 Relays + Isolated 4-20 mA Output Options
- Modbus[®] RTU Communication Protocol Standard

Order from:

C A Briggs Company

622 Mary Street; Suite 101

Warminster, PA 18974

Phone: 267-673-8117 - Fax: 267-673-8118

Sales@cabriggs.com - www.cabriggs.com

**PRECISION
DIGITAL** 

www.predig.com

Disclaimer

The information contained in this document is subject to change without notice. Precision Digital makes no representations or warranties with respect to the contents hereof and specifically disclaims any implied warranties of merchantability or fitness for a particular purpose.



CAUTION: *Read complete instructions prior to installation and operation of the meter.*



WARNING: *Risk of electric shock or personal injury.*



Warning!

This product is not recommended for life support applications or applications where malfunctioning could result in personal injury or property loss. Anyone using this product for such applications does so at his/her own risk. Precision Digital Corporation shall not be held liable for damages resulting from such improper use.

Limited Warranty

Precision Digital Corporation warrants this product against defects in material or workmanship for the specified period under “Specifications” from the date of shipment from the factory. Precision Digital’s liability under this limited warranty shall not exceed the purchase value, repair, or replacement of the defective unit.

Registered Trademarks

PROVU® and MeterView® Pro are registered trademarks of Precision Digital Corporation. Modbus® is a Registered Trademark of Schneider Automation Inc. All other trademarks mentioned in this document are the property of their respective owners.

© 2017 Precision Digital Corporation. All rights reserved.

www.predig.com

Table of Contents

Table of Contents -----	3
Table of Figures -----	4
Introduction -----	4
Ordering Information -----	5
Specifications -----	6
General -----	6
Dual Process Input -----	6
Dual Rate/Totalizer -----	7
Relays -----	8
Isolated 4-20 mA Transmitter Output -----	8
Modbus® RTU Serial Communications -----	8
MeterView Pro -----	8
Compliance Information -----	9
Safety -----	9
Electromagnetic Compatibility -----	9
Safety Information -----	10
Installation -----	10
Unpacking -----	10
Panel Mounting Instructions -----	10
Mounting Dimensions -----	11
Transmitter Supply Voltage Selection (P+, P-)-----	11
Connections -----	12
Connectors Labeling-----	12
Power Connections-----	12
Signal Connections-----	13
Modbus RTU Serial Communications-----	14
Relay Connections-----	14
Switching Inductive Loads-----	14
F4 Digital Input Connections-----	15
4-20 mA Output Connections-----	15
Analog Output Transmitter Power Supply-----	15
External Relay, Analog Output, & Digital I/O-----	16
Connections-----	16
Interlock Relay Feature-----	16
Setup and Programming -----	17
Front Panel Buttons and Status LED Indicators -----	17
MeterView® Pro Software -----	18
MeterView Pro Installation-----	18
Display Functions & Messages -----	19
Main Menu -----	22
Setting Numeric Values -----	22
Setting Up the Meter (SEtUP) -----	23
Setting the Input Signal (<i>inPUt</i>)-----	23
Setting the Totalizer Features (<i>tAtAL</i>)-----	24
Setting the Rate, Total, & Grand Total Units/Tags (<i>unItS</i>)-----	24
Setting the Decimal Point (<i>dEc Pt</i>)-----	25
Programming the Rate/Totalizer (<i>PrOU</i>)-----	26
Input Calibration Method (<i>InCAL</i>)-----	26
Scaling the Meter without a Signal Source (<i>SEtL - R, SEtL - b</i>)-----	27
Error Message (<i>ErrOr</i>)-----	27
Calibrating the Meter with External Source-----	28
Total and Grand Total Setup-----	29
Total & Grand Total Reset-----	29
Setting the Display Parameters & Intensity (<i>dSPLEy</i>)-----	30
Setting the Relay Operation (<i>rELAY</i>)-----	31
Setting the Relay Assignment (<i>ASSIGN</i>)-----	32
Setting the Relay Action (<i>Act</i>)-----	32
Programming Set and Reset Points-----	33
Setting Fail-Safe Operation-----	33
Programming Time Delay-----	33
Relay Action for Loss of 4-20 mA Input (Loop Break)-----	33
Relay and Alarm Operation Diagrams -----	34
High Alarm Operation (Set > Reset)-----	34
Low Alarm Operation (Set < Reset)-----	34
High Alarm with Fail-Safe Operation (Set > Reset)-----	34
Low Alarm with Fail-Safe Operation (Set < Reset)-----	34
Pump Alternation Control Operation-----	35
Relay Sampling Operation-----	35
Signal Loss or Loop Break Relay Operation-----	36
Time Delay Operation-----	36
Relay Operation Details -----	37
Overview-----	37
Relays Auto Initialization-----	37
Fail-Safe Operation-----	37
Front Panel LEDs-----	37
Latching and Non-Latching Relay Operation-----	38
Non-Latching Relay (<i>Auto</i>)-----	38
Non-Latching Relay (<i>R-nn Rn</i>)-----	38
Latching Relay (<i>LActH</i>)-----	38
Latching Relay (<i>Lt-Lr</i>)-----	38
Acknowledging Relays-----	39
Pump Alternation Control Applications (<i>ALtErn</i>)-----	39
Application #1: Pump Alternation Using Relays 1 & 2-----	39
Setting Up the Interlock Relay (Force On) Feature-----	40
Scaling the 4-20 mA Analog Output (<i>Auto</i>)-----	40
Reset Menu (<i>rESEt</i>)-----	41
Control Menu (<i>ContRl</i>)-----	41
Setting Up the Password (<i>PR55</i>)-----	41
Protecting or Locking the Meter Functions-----	41
Total Reset Password & Non-Resettable Total-----	42
Making Changes to a Password Protected Meter-----	42
Disabling Password Protection-----	42
Advanced Features Menu -----	43
Advanced Features Menu & Display Messages-----	43
Noise Filter (<i>FILtEr</i>)-----	45
Noise Filter Bypass (<i>bYPASS</i>)-----	45
Rounding Feature (<i>round</i>)-----	45
Modbus RTU Serial Communications (<i>SEr iAL</i>)-----	46
Select Menu (<i>SELEct</i>)-----	46
Signal Input Conditioning (<i>FunctiOn</i>)-----	47
Square Root Linearization (<i>SQRrE</i>)-----	47
Programmable Exponent Linearization (<i>PrOU E</i>)-----	47
Multi-Point Linearization (<i>L inER</i>)-----	47
Math Function (<i>math</i>)-----	48
Math Constants (<i>Const</i>)-----	48
Low-Flow Cutoff (<i>Cutoff</i>)-----	49
Totalizer Count Up/Down (<i>Count</i>)-----	49
Analog Output Programming (<i>AutoPr</i>)-----	49
Programmable Function Keys User Menu (<i>u5Er</i>)-----	50

Internal Calibration (μRL)-----	52	Diagnostics Menu ($d RL$)-----	54
Meter Operation -----	53	Determining Software Version -----	54
Front Panel Buttons Operation -----	53	Reset Meter to Factory Defaults-----	54
Function Keys Operation -----	53	Factory Defaults & User Settings-----	55
F4 Operation -----	53	Troubleshooting Tips -----	57
Maximum/Minimum Readings-----	53	EU Declaration of Conformity-----	59
Troubleshooting-----	54		

Table of Figures

Figure 1. 1/8 DIN Panel Cutout Dimensions.....	10	Powered.....	13
Figure 2. Panel Mounting Details.....	10	Figure 10. Voltage Input Connections.....	13
Figure 3. Meter Dimensions - Side View	11	Figure 11. Relay Connections.....	14
Figure 4. Meter Dimensions - Top View	11	Figure 12. AC and DC Loads Protection	14
Figure 5. Transmitter Supply Voltage Selection.....	11	Figure 13. Low Voltage DC Loads Protection	14
Figure 6. Connector Labeling for Fully Loaded		Figure 14. F4 Digital Input Connections	15
PD6262	12	Figure 15. 4-20 mA Output Connections.....	15
Figure 7. Power Connections.....	12	Figure 16. Interlock Connections	16
Figure 8. Transmitters Powered by Internal Supply.	13	Figure 17. Acknowledge Relays w/Function Key or	
Figure 9. Transmitter Powered by Ext. Supply or Self-		Digital Input	39

Introduction

The PROVU® PD6262 is a multipurpose, easy to use digital dual analog input rate/totalizer ideal for flow rate, total, and flow control applications. Its superluminous LED digits make it easily readable in smoke, dust, fog, and, with the optional SunBright® display, even direct sunlight.

It accepts two current or voltage signals (e.g. 4-20 mA, 0-10 V). Various math functions may be applied to the rate, total, or grand totals of the two channels; including addition, difference, average, minimum, maximum, draw, ratio and more. This is in addition to the signal input conditioning functions; linear, square root, or programmable exponent.

The displays, relays, and the analog output may be assigned to the rate, total, or grand total of input channels A or B; or math result channel C. Three of the front panel buttons can be custom-programmed for a specific operation.

The basic model includes an isolated 24 VDC transmitter power supply that can be used to power the input transmitters or other devices. An additional isolated 24 VDC power supply is included with the 4-20 mA output option. A digital input is standard.

A fully loaded PD6262 meter has the following: four SPDT relays, 4-20 mA output, and two 24 VDC power supplies. The PD6262 capabilities may be enhanced by adding the following external expansion modules: four SPST relays –creating an eight-relay dual-input process meter, two digital I/O modules with four inputs and four outputs each, serial communication adapters for use with MeterView Pro or Modbus RTU, and a dual isolated 4-20 mA output expansion module.

Ordering Information

Standard Models

85-265 VAC Model	12-24 VDC Model	Options Installed
PD6262-6R0	PD6262-7R0	No options
PD6262-6R2	PD6262-7R2	2 relays (PD1102*)
PD6262-6R3	PD6262-7R3	4-20 mA output (PD1103*)
PD6262-6R4	PD6262-7R4	4 relays (PD1104*)
PD6262-6R5	PD6262-7R5	2 relays & 4-20 mA output (PD1105*)
PD6262-6R7	PD6262-7R7	4 relays & 4-20 mA output (PD1107*)
*Model number for replacement option card.		

SunBright Display Models

85-265 VAC Model	12-24 VDC Model	Options Installed
PD6262-6H0	PD6262-7H0	No options
PD6262-6H2	PD6262-7H2	2 relays (PD1102*)
PD6262-6H3	PD6262-7H3	4-20 mA output (PD1103*)
PD6262-6H4	PD6262-7H4	4 relays (PD1104*)
PD6262-6H5	PD6262-7H5	2 relays & 4-20 mA output (PD1105*)
PD6262-6H7	PD6262-7H7	4 relays & 4-20 mA output (PD1107*)
*Model number for replacement option card.		

Accessories

Model	Description
PDA1002	DIN rail mounting kit for two expansion modules
PDA1004	4 SPST (Form A) relays
PDA1011	Dual isolated 4-20 mA output expansion module
PDA1044	4 digital inputs & 4 digital outputs (2 may be connected)
PDA1232	RS-232 serial adapter
PDA1485	RS-485 serial adapter
PDA7485-I	RS-232 to RS-422/485 isolated converter
PDA7485-N	RS-232 to RS-422/485 non-isolated converter
PDA8232-N	USB to RS-232 non-isolated converter
PDA8485-I	USB to RS-422/485 isolated converter
PDA8485-N	USB to RS-422/485 non-isolated converter
PDX6901	Suppressor (snubber): 0.01 μ F/470 Ω , 250 VAC

Specifications

Except where noted all specifications apply to operation at +25°C.

General

Display	Line 1: 0.60" (15 mm) high, red LEDs Line 2: 0.46" (12 mm) high, red LEDs 6 digits each (-99999 to 999999), with lead zero blanking
Display Intensity	Eight user selectable intensity levels
Display Update Rate	5/second (200 ms)
Overrange	Display flashes 999999
Underrange	Display flashes -99999
Display Assignment	Display lines 1 & 2 may be assigned to show: One or more rate channels: Channel A (Ch-A), B (Ch-B), or C (Ch-C) Toggle between rate channels: Ch-A & Ch-B, Ch-A & Ch-C, Ch-B & Ch-C, and Ch-A, Ch-B, & Ch-C Total or grand total: Ch-A or Ch-B Rate and total or grand total: Ch-A, Ch-B Relay set points Max and/or min values: Ch-A, Ch-B, or Ch-C Toggle between any rate channel & units Total and units: Ch-A or Ch-B Toggle between totals: Ch-A & Ch-B; Ch-A, Ch-B, and sum of Ch-A and Ch-B Modbus input Line 2 may also be set to show engineering units or be off, with no display.
Programming Methods	Four front panel buttons, digital inputs, PC and MeterView Pro software, or Modbus registers.
Max/Min Display	Max/min readings reached by the process are stored until reset by the user or until power to the meter is cycled.
Password	Three programmable passwords restrict modification of programmed settings and two prevent resetting the totals. Pass 1: Allows use of function keys and digital inputs Pass 2: Allows use of function keys, digital inputs and editing set/reset points Pass 3: Restricts all programming, function keys, and digital inputs. Total: Prevents resetting the total manually Gtotal: Prevents resetting the grand total manually
Noise Filter	Programmable from 2 to 199 (0 will disable filter)
Filter Bypass	Programmable from 0.1 to 99.9% of calibrated span
Recalibration	All ranges are calibrated at the factory. Recalibration is recommended at least every 12 months.
Non-Volatile Memory	All programmed settings are stored in non-volatile memory for a minimum of ten years.

Power Options	85-265 VAC 50/60 Hz, 90-265 VDC, 20 W max or 12-24 VDC \pm 10%, 15 W max Powered over USB for configuration only
Fuse	Required external fuse: UL Recognized, 5 A max, slow blow; up to 6 meters may share one 5 A fuse
Isolated Transmitter Power Supply	Terminals P+ & P-: 24 VDC \pm 10%. Selectable for 24, 10, or 5 VDC supply (internal jumper J4). 85-265 VAC models rated @ 200 mA max, 12-24 VDC powered models rated @ 100 mA max, @ 50 mA max for 5 or 10 VDC supply.
Normal Mode Rejection	Greater than 60 dB at 50/60 Hz
Isolation	4 kV input/output-to-power line 500 V input-to-output or output-to-P+ supply
Overvoltage Category	Installation Overvoltage Category II: Local level with smaller transient overvoltages than Installation Overvoltage Category III.
Environmental	Operating temperature range: -40 to 65°C Storage temperature range: -40 to 85°C Relative humidity: 0 to 90% non-condensing
Connections	Removable screw terminal blocks accept 12 to 22 AWG wire, RJ45 for external relays, digital I/O, and serial communication adapters.
Enclosure	1/8 DIN, high impact plastic, UL 94V-0, color: black
Mounting	1/8 DIN panel cutout required: 3.622" x 1.772" (92 mm x 45 mm) Two panel mounting bracket assemblies are provided.
Tightening Torque	Screw terminal connectors: 5 lb-in (0.56 Nm)
Overall Dimensions	4.68" x 2.45" x 5.64" (119 mm x 62 mm x 143 mm) (W x H x D)
Weight	9.5 oz (269 g)
Warranty	3 years parts & labor

Dual Process Input

Two Inputs	Two non-isolated inputs, each separately field selectable: 0-20, 4-20 mA, \pm 10 V (0-5, 1-5, 0-10 V), Modbus PV (Slave)
Channels	Channel A, Channel B, Channel C (Math channel)
Programmable Constants	Constant P (Adder): -99.999 to 999.999, default: 0.000 Constant F (Factor): 0.001 to 999.999, default: 1.000

Math Functions		
Name	Function	Setting
Addition	$(A+B+P)*F$	Sum
Difference	$(A-B+P)*F$	dIF
Absolute diff.	$((Abs(A-B))+P)*F$	dIFRb5
Average	$((A+B)/2)+P)*F$	AVG
Multiplication	$((A*B)+P)*F$	mulE
Division	$((A/B)+P)*F$	dIFdE
Max of A or B	$((AB-Hi)+P)*F$	HIFRb
Min of A or B	$((AB-Lo)+P)*F$	LoRb
Draw	$((A/B)-1)*F$	drRb
Weighted avg.	$((B-A)*F)+A$	WAVG
Ratio	$(A/B)*F$	rRtE
Ratio 2	$((B-A)/A)+P)*F$	rRtEoZ
Concentration	$A/(A+B)*F$	ConcEn
Total Addition	$(tA+tB+P)*F$	Sum t
G. Tot. Addition	$(GtA+GtB+P)*F$	SumRtE
Total Difference	$(tA-tB+P)*F$	dIF t
G. Tot. Difference	$(GtA-GtB+P)*F$	dIF RtE
Total Ratio	$(tA/tB)*F$	tRtE
Total Ratio 2	$((tB-tA)/tA)*F$	t-rRtEZ
Total Percent	$(tA/(tA+tB))*100$	tPct

Note: The F constant can be any value from 0.001 to 999.999. If the value is less than 1, it will have the same effect as a divider. For example, the average could also be derived by using $(A+B)*F$, where $F = 0.500$.

Sequence of Operations for Input Programming	Steps
1.	Select Input for A and B
2.	Set up the rate, total, and grand total engineering units for channels A & B, and units for math channel C
3.	Set up rate, total, and grand total decimal points for channels A & B, and decimal point for math channel C
4.	Program channel A & B rate parameters
5.	Program channel A & B total and reset parameters
6.	Set up display lines 1 and 2
7.	Select the transfer function for A & B (e.g. Linear)
8.	Select Math function for Channel C
9.	Program constants for Factor (F) and Adder (P).
10.	Program cutoff values for A and B

Accuracy	$\pm 0.03\%$ of calibrated span ± 1 count, square root & programmable exponent accuracy range: 10-100% of calibrated span
Temperature Drift	0.005% of calibrated span/ $^{\circ}\text{C}$ max from 0 to 65°C ambient, 0.01% of calibrated span/ $^{\circ}\text{C}$ max from -40 to 0°C ambient
Signal Input Conditioning	Linear, square root, or programmable exponent
Multi-Point Linearization	2 to 32 points for channel A and B
Programmable Exponent	1.0001 to 2.9999
Low-Flow Cutoff	0-999999 (0 disables cutoff function)
Decimal Point	Up to five decimal places or none: d.ddddd, d.ddddd, d.ddd, ddd, dd, or d

Calibration Range	Input Range 4-20 mA ± 10 V An error message will appear if the input 1 and input 2 signals are too close together.	Minimum Span Input 1 & Input 2 0.15 mA 0.01 V
Input Impedance	Voltage ranges: greater than 500 k Ω Current ranges: 50 - 100 Ω (depending on resettable fuse impedance)	
Input Overload	Current input protected by resettable fuse, 30 VDC max. Fuse resets automatically after fault is removed.	
F4 Digital Input Contacts	3.3 VDC on contact. Connect normally open contacts across F4 to COM.	
F4 Digital Input Logic Levels	Logic High: 3 to 5 VDC Logic Low: 0 to 1.25 VDC	

Dual Rate/Totalizer

Rate Display Indication	-99999 to 999999, lead zero blanking.
Total Display & Total Overflow	0 to 999,999; automatic lead zero blanking. Up to 999,999,999 with total-overflow feature. "oF" is displayed to the left of total overflow and \blacktriangle LED is illuminated.
Total Decimal Points	Up to five decimal places or none: d.ddddd, d.ddddd, d.ddd, ddd, dd, or d Total decimal point is independent of rate decimal point. Channel A and B decimal points programmed independently.
Dual Totalizer	Calculates total for channels A and B based on rate and field programmable multiplier to display total in engineering units. Time base must be selected according to the time units in which the rate is displayed. Channel A and B totalizer parameters programmed independently.
Totalizer Rollover	Totalizer rolls over when display exceeds 999,999,999. Relay status reflects display.
Total Overflow Override	Program total A or B total reset for automatic with 0.1 second delay and set point 1 for 999,999
Totalizer Alarm Presets	Up to eight, user selectable under setup menu. Any set point can be assigned to channel A or B total or grand total (or C) and may be programmed anywhere in the range of the meter for total alarm indication.
Total Reset Password	Total and grand total passwords may be entered to prevent resetting the totals or grand totals from the front panel.
Total & Grand Total Reset	Via front panel button, external contact closure on digital inputs, automatically via user selectable preset value and time delay, or through serial communications. Channel A and B total and grand total reset parameters programmed independently.
Programmable Delay On Release	0.1 and 999.9 seconds; applied to the first relay assigned to total or grand total. If the meter is programmed to reset total to zero automatically when the preset is reached, then a delay will occur before the total is reset.

Non-Resetable Total	The grand totals can be programmed as non-resetable totals by entering the password "050873". Both channels are set to non-resetable when this password is entered.
	 <p>Caution! <i>Once the Grand Totals have been programmed as "non-resetable" the feature cannot be disabled.</i></p>
Relays	
Rating	2 or 4 SPDT (Form C) internal and/or 4 SPST (Form A) external; rated 3 A @ 30 VDC and 125/250 VAC resistive load; 1/14 HP (\approx 50 W) @ 125/250 VAC for inductive loads
Noise Suppression	Noise suppression is recommended for each relay contact switching inductive loads; see page 14 for details.
Relay Assignment	Relays may be assigned to channel A or B rate, total, or grand total; channel C; or Modbus control.
Deadband	0-100% of span, user programmable
High Or Low Alarm	User may program any alarm for high or low trip point. Unused alarm LEDs and relays may be disabled (turn off).
Relay Operation	Automatic (non-latching) Latching (requires manual acknowledge) Sampling (based on time) Pump alternation control (2 to 8 relays) Off (disable unused relays and enable Interlock feature) Manual on/off control mode
Relay Reset	User selectable via front panel buttons, digital inputs, or PC <ol style="list-style-type: none"> Automatic reset only (non-latching), when the input passes the reset point. Automatic + manual reset at any time (non-latching) Manual reset only, at any time (latching) Manual reset only after alarm condition has cleared (L) <p><i>Note: Front panel button or digital input may be assigned to acknowledge relays programmed for manual reset.</i></p>
Time Delay	0 to 999.9 seconds, on & off relay time delays Programmable and independent for each relay
Fail-Safe Operation	Programmable and independent for each relay. <i>Note: Relay coil is energized in non-alarm condition. In case of power failure, relay will go to alarm state.</i>
Auto Initialization	When power is applied to the meter, relays will reflect the state of the input to the meter.

Isolated 4-20 mA Transmitter Output

Output Source	Input channels A or B, rate, total, or grand total; channel C; max or min for channel A or B; highest or lowest max or min of A and B; set points 1-8; Modbus input; or manual control mode		
Scaling Range	1.000 to 23.000 mA for any display range		
Calibration	Factory calibrated: 4.000 to 20.000 = 4-20 mA output		
Analog Out Programming	23.000 mA maximum for all parameters: Overrange, underrange, max, min, and break		
Accuracy	$\pm 0.1\%$ of span ± 0.004 mA		
Temperature Drift	0.4 μ A/ $^{\circ}$ C max from 0 to 65 $^{\circ}$ C ambient, 0.8 μ A/ $^{\circ}$ C max from -40 to 0 $^{\circ}$ C ambient <i>Note: Analog output drift is separate from input drift.</i>		
Isolated Transmitter Power Supply	Terminals I+ & R: 24 VDC \pm 10%. May be used to power the 4-20 mA output or other devices. Refer to Figure 6 on page 12 and Figure 15 on page 15. All models rated @ 40 mA max.		
External Loop Power Supply	35 VDC maximum		
Output Loop Resistance	Power supply	Minimum	Maximum
	24 VDC	10 Ω	700 Ω
	35 VDC (external)	100 Ω	1200 Ω

Modbus® RTU Serial Communications

Slave Id	1 – 247 (Meter address)
Baud Rate	300 – 19,200 bps
Transmit Time Delay	Programmable between 0 and 199 ms
Data	8 bit (1 start bit, 1 or 2 stop bits)
Parity	Even, Odd, or None with 1 or 2 stop bits
Byte-To-Byte Timeout	0.01 – 2.54 second
Turn Around Delay	Less than 2 ms (fixed)

Note: Refer to the PROVU® Modbus Register Tables located at www.predig.com for details.

MeterView Pro

System Requirements	Microsoft® Windows® XP/Vista/7/8/10
Communications	USB 2.0 (Standard USB A to Micro USB B)
Configuration	Configure meters one at a time

Compliance Information

Safety

UL & c-UL Listed	USA & Canada UL 508 Industrial Control Equipment
UL File Number	E160849
Front Panel	UL Type 4X, NEMA 4X, IP65; panel gasket provided
Low Voltage Directive	EN 61010-1:2010 Safety requirements for measurement, control, and laboratory use

Electromagnetic Compatibility

Emissions	EN 55022:2010 Class A ITE emissions requirements
Radiated Emissions	Class A
AC Mains Conducted Emissions	Class A
Immunity	EN 61326-1:2013 Measurement, control, and laboratory equipment EN 61000-6-2:2005 EMC heavy industrial generic immunity standard
RFI - Amplitude Modulated	80 -1000 MHz 10 V/m 80% AM (1 kHz) 1.4 - 2.0 GHz 3 V/m 80% AM (1 kHz) 2.0 - 2.7 GHz 1 V/m 80% AM (1 kHz)
Electrical Fast Transients	±2kV AC mains, ±1kV other
Electrostatic Discharge	±4kV contact, ±8kV air
RFI - Conducted	10V, 0.15-80 MHz, 1kHz 80% AM
AC Surge	±2kV Common, ±1kV Differential
Surge	1KV (CM)
Power-Frequency Magnetic Field	30 A/m 70%V for 0.5 period
Voltage Dips	40%V for 5 & 50 periods 70%V for 25 periods
Voltage Interruptions	<5%V for 250 periods

Note:

Testing was conducted on PD6200 Series meters installed through the covers of grounded metal enclosures with cable shields grounded at the point of entry representing installations designed to optimize EMC performance.

Declaration of Conformity available at www.predig.com

Safety Information

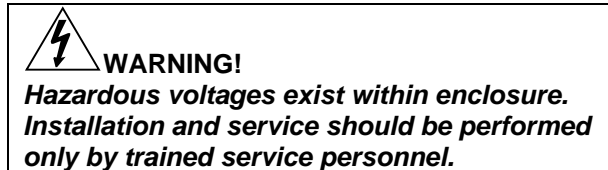
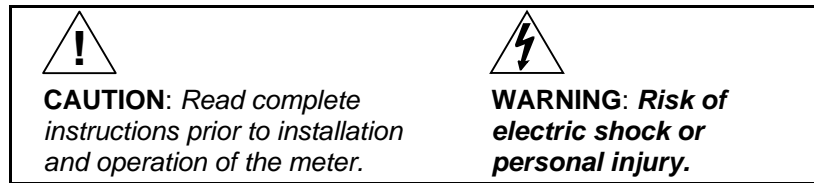

Installation

There is no need to remove the meter from its case to complete the installation, wiring, and setup of the meter for most applications.

Instructions are provided for changing the transmitter power supply to output 5 or 10 VDC instead of 24 VDC, see page 11.

Unpacking

Remove the meter from box. Inspect the packaging and contents for damage. Report damages, if any, to the carrier.

If any part is missing or the meter malfunctions, please contact your supplier or the factory for assistance.

Panel Mounting Instructions

- Prepare a standard 1/8 DIN panel cutout – 3.622" x 1.772" (92 mm x 45 mm). Refer to Figure 1 below, for more details.
- Clearance: allow at least 6.0" (152 mm) behind the panel for wiring.
- Panel thickness: 0.04" - 0.25" (1.0 mm - 6.4 mm).
Recommended minimum panel thickness to maintain Type 4X rating: 0.06" (1.5 mm) steel panel, 0.16" (4.1 mm) plastic panel.
- Remove the two mounting brackets provided with the meter (back-off the two screws so that there is ¼" (6.4 mm) or less through the bracket. Slide the bracket toward the front of the case and remove).
- Insert meter into the panel cutout.
- Install mounting brackets and tighten the screws against the panel. To achieve a proper seal, tighten the mounting bracket screws evenly until meter is snug to the panel along its short side. **DO NOT OVER TIGHTEN**, as the rear of the panel may be damaged.

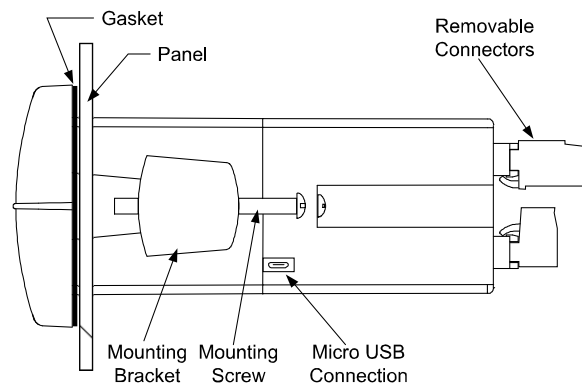
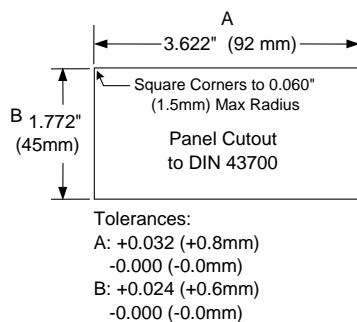

Mounting Dimensions

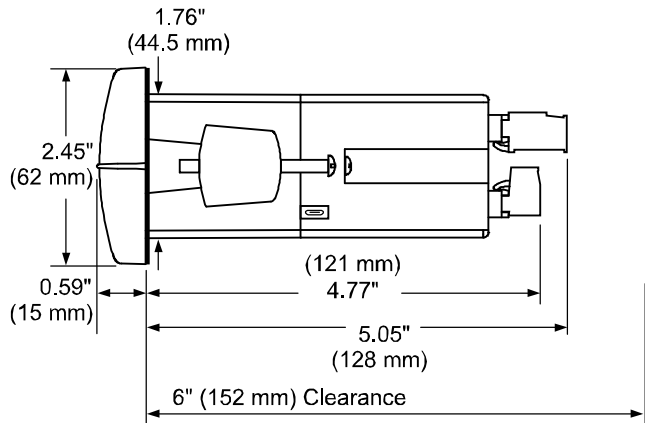

Figure 3. Meter Dimensions - Side View

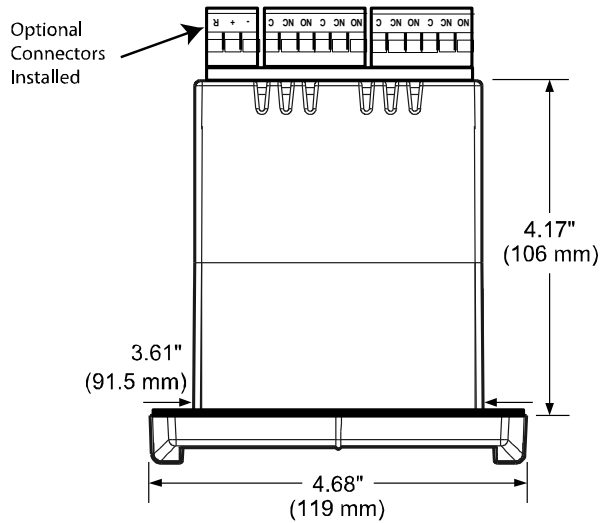

Figure 4. Meter Dimensions - Top View

Transmitter Supply Voltage Selection (P+, P-)

All meters, including models equipped with the 12-24 VDC power option, are shipped from the factory configured to provide 24 VDC power for the transmitter or sensor.

If the transmitter requires 5 or 10 VDC excitation, the internal jumper J4 must be configured accordingly.

To access the voltage selection jumper:

1. Remove all the wiring connectors.
2. Unscrew the back cover.
3. Slide out the back cover by about 1 inch.
4. Configure the J4 jumper, located behind the input signal connector, for the desired excitation voltage as shown.

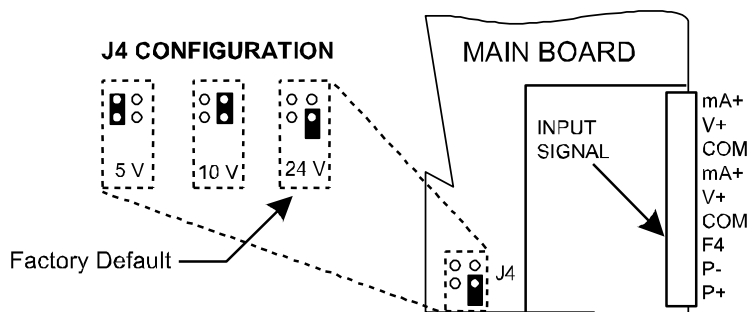



Figure 5. Transmitter Supply Voltage Selection

Connections

All connections are made to removable screw terminal connectors located at the rear of the meter.



Caution! Use copper wire with 60°C or 60/75°C insulation for all line voltage connections. Observe all safety regulations. Electrical wiring should be performed in accordance with all applicable national, state, and local codes to prevent damage to the meter and ensure personnel safety.

Connectors Labeling

The connectors' label, affixed to the meter, shows the location of all connectors available with requested configuration.

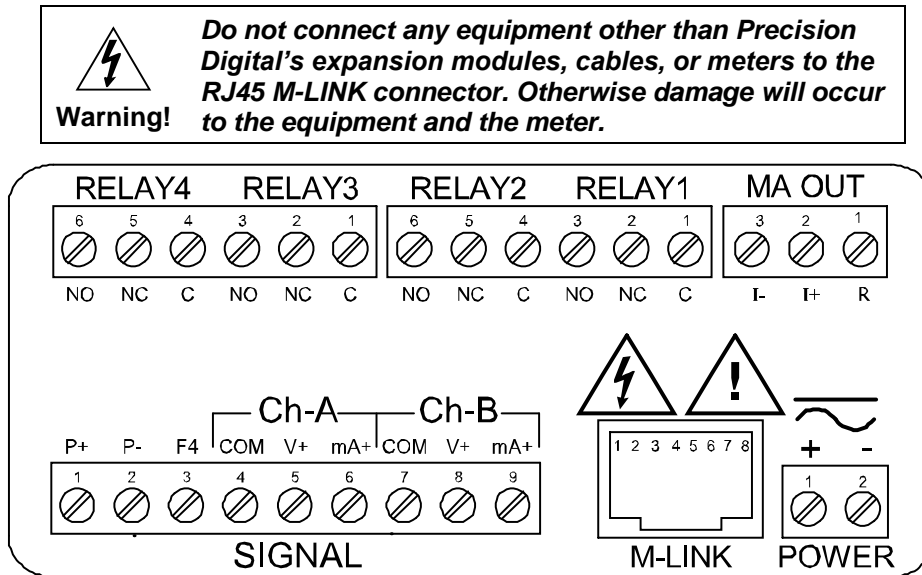
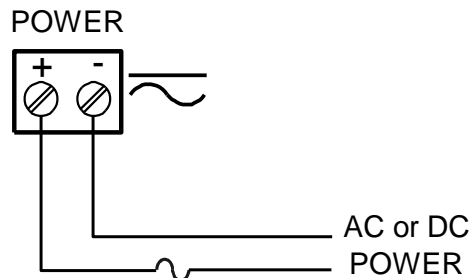

Figure 6. Connector Labeling for Fully Loaded PD6262

Power Connections

Power connections are made to a two-terminal connector labeled POWER on Figure 6. The meter will operate regardless of DC polarity connection. The + and - symbols are only a suggested wiring convention.



Required External Fuse:
5 A max, 250 V Slow Blow

Figure 7. Power Connections

Signal Connections

Signal connections are made to a nine-terminal connector labeled SIGNAL on Figure 6. The COM (common) terminals are the return for the 4-20 mA and the ± 10 V input signals. The two COM terminals connect to the same common return, and are not isolated.

Current and Voltage Connections

The following figures show examples of current and voltage connections.

There are no switches or jumpers to set up for current and voltage inputs. Setup and programming is performed through the front panel buttons.

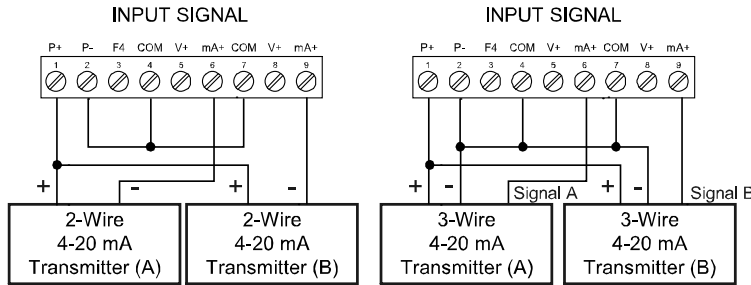

Figure 8. Transmitters Powered by Internal Supply

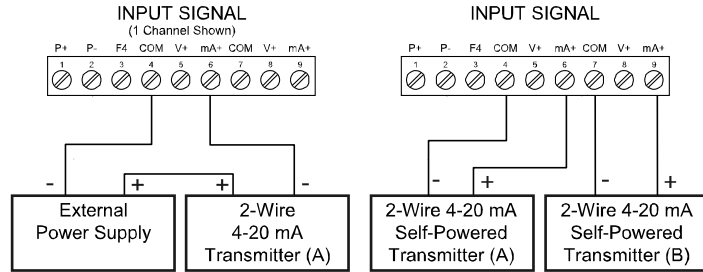

Figure 9. Transmitter Powered by Ext. Supply or Self-Powered

The current input is protected against current overload by a resettable fuse. The display may or may not show a fault condition depending on the nature of the overload.

The fuse limits the current to a safe level when it detects a fault condition, and automatically resets itself when the fault condition is removed.

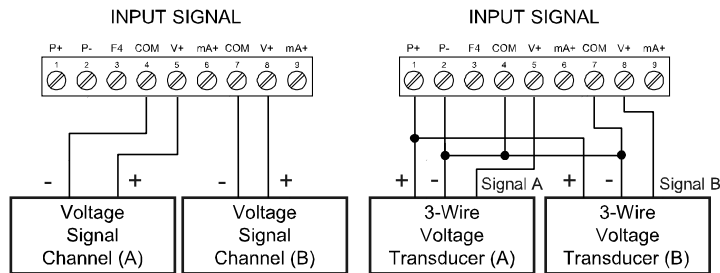

Figure 10. Voltage Input Connections

The meter is capable of accepting any voltage from -10 VDC to +10 VDC.

Modbus RTU Serial Communications

Serial communications connection is made to an RJ45 connector labeled M-LINK on Figure 6. For interfacing to the PROVu®, use the PDA1232 for RS-232 or the PDA1485 for RS-485. The same port is used for interfacing with all expansion modules (e.g. external relays, additional 4-20 mA outputs, digital I/O).

Relay Connections

Relay connections are made to two six-terminal connectors labeled RELAY1 – RELAY4 on Figure 6. Each relay's C terminal is common only to the normally open (NO) and normally closed (NC) contacts of the corresponding relay. The relays' C terminals should not be confused with the COM (common) terminal of the INPUT SIGNAL connector.

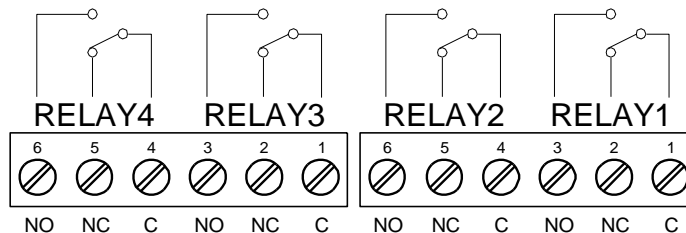

Figure 11. Relay Connections

Switching Inductive Loads

The use of suppressors (snubbers) is strongly recommended when switching inductive loads to prevent disrupting the microprocessor's operation. The suppressors also prolong the life of the relay contacts. Suppression can be obtained with resistor-capacitor (RC) networks assembled by the user or purchased as complete assemblies. Refer to the following circuits for RC network assembly and installation:

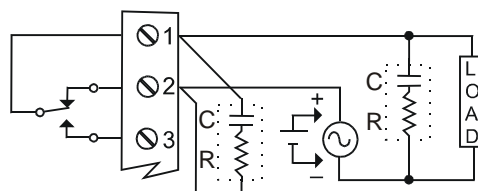

Figure 12. AC and DC Loads Protection

Choose R and C as follows:

R: 0.5 to 1 Ω for each volt across the contacts

C: 0.5 to 1 μ F for each amp through closed contacts

Notes:

1. Use capacitors rated for 250 VAC.
2. RC networks may affect load release time of solenoid loads. Check to confirm proper operation.
3. Install the RC network at the meter's relay screw terminals. An RC network may also be installed across the load. Experiment for best results.

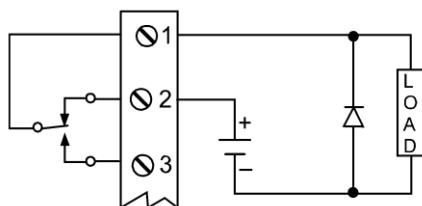

Use a diode with a reverse breakdown voltage two to three times the circuit voltage and forward current at least as large as the load current.

Figure 13. Low Voltage DC Loads Protection

RC Networks Available from Precision Digital

RC networks are available from Precision Digital and should be applied to each relay contact switching an inductive load. Part number: PDX6901.

Note: Relays are de-rated to 1/14th HP (50 watts) with an inductive load.

F4 Digital Input Connections

A digital input, F4, is standard on the meter. This digital input connected with a normally open closure across F4 and COM, or with an active low signal applied to F4.

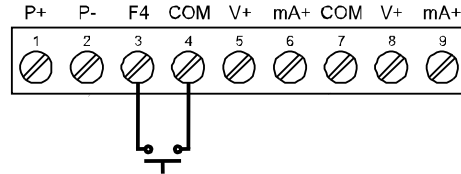

Figure 14. F4 Digital Input Connections

4-20 mA Output Connections

Connections for the 4-20 mA transmitter output are made to the connector terminals labeled MA OUT. The 4-20 mA output may be powered internally or from an external power supply.

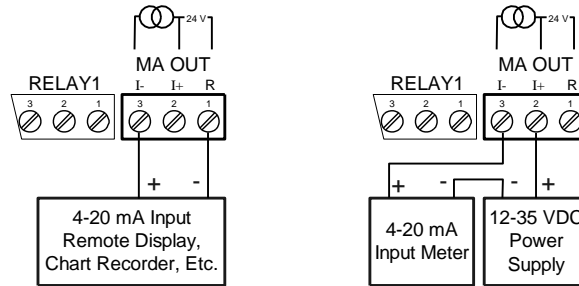

Figure 15. 4-20 mA Output Connections

Analog Output Transmitter Power Supply

The internal 24 VDC power supply powering the analog output may be used to power other devices, if the analog output is not used. The I+ terminal is the +24 V and the R terminal is the return.

External Relay, Analog Output, & Digital I/O Connections

The relay, analog out, and digital I/O expansion modules PDA1004, PDA1011, and PDA1044 are connected to the meter using a CAT5 cable provided with each module. The two RJ45 connectors on the expansion modules are identical and interchangeable; they are used to connect additional modules to the system.

Note: The jumper located between the RJ45 connectors of the PDA1044 must be removed on the second digital I/O module in order for the system to recognize it as module #2.



Warning! *Do not connect or disconnect the expansion modules with the power on! More detailed instructions are provided with each optional expansion module.*

Interlock Relay Feature

As the name implies, the interlock relay feature reassigns one, or more, alarm/control relays for use as interlock relay(s). Interlock contact(s) are wired to digital input(s) and trigger the interlock relay. This feature is enabled by configuring the relay, and relative digital input(s) (see page 40). In one example, dry interlock contacts are connected in series to one digital input which will be used to force on (energize) the assigned interlock power relay when all interlock contacts are closed (safe). The interlock relay front panel LED flashes when locked out. The interlock relay would be wired in-series with the load (N/O contact). See below.

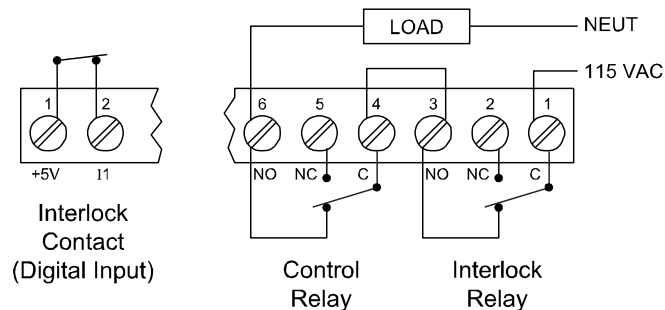

Figure 16. Interlock Connections

Setup and Programming

The meter is factory calibrated prior to shipment to read in milliamps and volts, depending on the input selection. The calibration equipment is certified to NIST standards.

Overview





There are no jumpers to set for the meter input selection.

Setup and programming is done through the front panel buttons.

After power and input signal connections have been completed and verified, apply power to the meter.

Front Panel Buttons and Status LED Indicators



Button Symbol	Description	LED	Status
	Menu	1-8	Alarm 1-8 indicator
	Right arrow/F1	1-8 M	Flashing: Relay in manual control mode
	Up arrow/F2	A B C	Channel displayed
	Enter/F3	1-4	Flashing: Relay interlock switch open
<p><i>Notes:</i> F4 is a digital input. Alarms 5-8 are enabled when relay expansion module installed.</p>		<p><i>Note:</i> LEDs for relays in manual mode flash with the "M" LED every 10 seconds.</p>	

- Press the Menu button to enter or exit the Programming Mode at any time.
- Press the Right arrow button to move to the next digit during digit or decimal point programming.
- Press or hold the Up arrow button to scroll through the menus, decimal point, or to increment the value of a digit.
- Press the Enter button to access a menu or to accept a setting.
- Press and hold the Menu button for three seconds to access the advanced features of the meter.

MeterView® Pro Software

The meter can also be programmed using the PC-based MeterView Pro software included with the meter. This software can be installed on any Microsoft® Windows® (XP/Vista/7/8/10) computer by connecting the meter's onboard USB. The meter is powered by the USB connection, so there is no need to wire anything prior to programming the meter, though USB is intended only for meter configuration.

MeterView Pro Installation

1. Connect one end of the provided USB cable to the meter and the other end to the computer. The computer will automatically install the driver software it needs to talk to the meter.

Only one meter may be connected at a time. Attaching multiple meters will cause a conflict with the meter software.

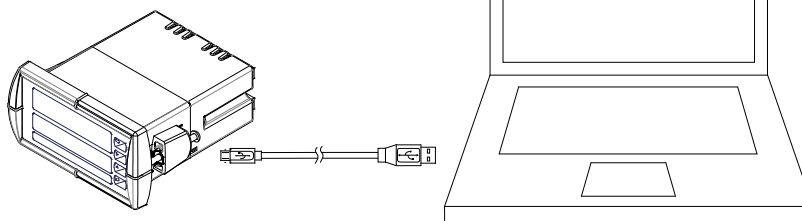

2. Once the driver is installed, an AutoPlay dialog should appear for the drive "MAINSTAL." Click "Open folder to view files." If the computer does not display an AutoPlay dialog for the drive "MAINSTAL," you should open My Computer and double-click on the drive labeled "MAINSTAL."
3. Double-click on the file named "MAStart." The program will open a few windows and install two programs on your computer. Simply follow the onscreen instructions until you see one of the dialogs below. If you receive a "User Account Control" warning, click "Yes."
4. If there is an update available, click the "Update" button to install the new version. Otherwise, click "Configure" to begin programming your meter.

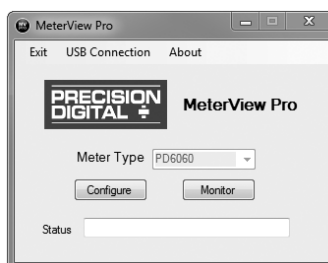
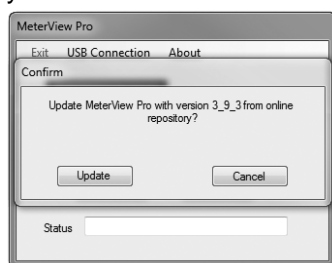
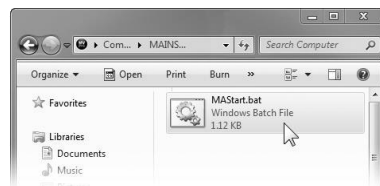

Note: If you decide to update your MeterView Pro software, once the installation has completed, you will be asked if you want to update the setup files located on the meter itself. This way, you will always have the most current version on the meter for future installs.



Do not unplug the meter while the new installation files are being written to it. The meter will display $\mu r t E$ during the process and you will receive an onscreen notification once the process is complete.

Data logging for one meter at a time is available with MeterView Pro software. More advanced data acquisition may be accomplished by using any Modbus RTU compliant software. Additional information regarding configuration and monitoring of the meter using MeterView Pro software is available online. Go to www.predig.com/meterview-pro.

Display Functions & Messages

The following table shows the main menu functions and messages in the order they appear in the menu.

Display	Parameter	Action/Setting Description
SEtUP	Setup	Enter Setup menu
inPUt	Input	Enter Input selection menu
Ch-A*	Input	Set input type for channel A (*or B)
m A	4-20 mA	Set meter for 4-20 mA input
VolT	0-10 VDC	Set meter for ±10 VDC input
toTAL	Total	Enable/disable totalizer functions
YES	Yes	Enable totalizer functions
no	No	Disable totalizer functions
un iT5	Unit	Select the display units/tags
Ch-A*	Rate unit	Set rate unit or tag for channel A (*or B)
Ch-C	Math unit	Set unit or tag for math channel C
toT-A*	Total unit	Set total unit or tag for channel A (*or B)
GrtoT-A*	Grand total unit	Set grand total unit or tag for channel A (*or B)
dEc Pt	Decimal point	Set decimal point
Ch-A*	Decimal point	Set decimal point for channel A (*or B or C)
rALtE*	Rate	Set rate decimal point (*channel A and B only)
toTAL*	Total	Set total decimal point (*channel A and B only)
GrtoTAL*	Grand total	Set grand total decimal point (*channel A and B only)
PrOG	Program	Enter the Program menu
inCAL	Input calibration	Enter the Input Calibration menu
SCALE A	Scale A	Enter the Scale menu for channel A
SCALE b	Scale B	Enter the Scale menu for channel B
CAL A	Calibrate A	Enter the Calibration menu for channel A

Display	Parameter	Action/Setting Description
CAL b	Calibrate B	Enter the Calibration menu for channel B
inP 1	Input 1	Calibrate input 1 signal or program input 1 value
d IS 1	Display 1	Program display 1 value
inP 2	Input 2	Calibrate input 2 signal or program input 2 value (up to 32 points)
d IS 2	Display 2	Program display 2 value (up to 32 points)
Error	Error	Error, calibration not successful, check signal or programmed value
tSEtUP	Total setup	Enter the Total Setup menu
Ch-A*	Channel A	Setup the total for channel A (*or B)
tBASE	Time base	Program total time base
t CF	Total conversion factor	Program total conversion factor
Gr t CF	Grand total conversion factor	Program grand total conversion factor
tRESEt	Total reset	Program total reset mode: auto or manual
Ch-A*	Channel A	Set total reset modes for channel A (*or B)
t r5t	Total reset	Program total reset mode: auto or manual
Gr t r5t	Grand total reset	Program grand total reset mode: auto or manual
t dLY	Time delay	Program automatic reset time delay
dSPLY	Display	Enter the Display menu
L nE 1	Line 1	Assign the upper display parameter
L nE 2	Line 2	Assign the lower display parameter
d Ch-A	Display Ch-A	Assign display to channel A
d Ch-b	Display Ch-B	Assign display to channel B
d Ch-C	Display Ch-C	Assign display to channel C (math)

Display	Parameter	Action/Setting Description
d Rb	Display AB	Alternate display of channel A & B
d RĀ	Display AC	Alternate display of channel A & C
d bĀ	Display BC	Alternate display of channel B & C
d RbĀ	Display ABC	Alternate display of channel A, B, & C
d Ē-R	Display total A	Assign display to channel A total
d Ē-b	Display total B	Assign display to channel B total
d ĀĒ-R	Display grand total A	Assign display to channel A grand total
d ĀĒ-b	Display grand total B	Assign display to channel B grand total
d rĒ-R	Display rate and total A	Alternate display of channel A rate and total
d rĒ-b	Display rate and total B	Alternate display of channel B rate and total
drĀĒ-R	Display rate and grand total A	Alternate display of channel A rate and grand total
drĀĒ-b	Display rate and grand total B	Alternate display of channel B rate and grand total
d SEĒ 1*	Display Set 1*	Displays relay 1(*through 8) set point.
d H Ē-R	Display high A	Display high value of channel A
d Lo-R	Display low A	Display low value of channel A
d HL-R	Display high/low A	Alternate between high/low value of channel A
d H Ē-b	Display high B	Display high value of channel B
d Lo-b	Display low B	Display low value of channel B
d HL-b	Display High/low B	Alternate between high/low value of channel B

Display	Parameter	Action/Setting Description
d H Ē-Ā	Display high C	Display high value of channel C
d Lo-Ā	Display low C	Display low value of channel C
d HL-Ā	Display High/low C	Alternate between high/low value of channel C
d R-Ē	Display A and units/tags	Alternate display of channel A and the unit/tag
d b-Ē	Display B and units/tags	Alternate display of channel B and the unit/tag
d Ā-Ē	Display C and units/tags	Alternate display of channel C and the unit/tag
d ĒR-Ē	Display total A and total units A	Alternate display of channel A total and total units
d Ēb-Ē	Display total B and total units B	Alternate display of channel B total and total units
d ĒRb	Display total A and B	Alternate display of channel A total and channel B total
d ĒRbĀ	Display total A, B, and math channel C	Alternate display of channel A total, channel B total, and math result channel C
rr b5	Display Modbus	Display Modbus input register
d oFF	Display off	Display blank line 2
d un Ē	Display unit	Display line 1 channel units
d- ĒĒ	Display intensity	Set display intensity level from 1 to 8
rĒRAY	Relay	Enter the Relay menu
R55 Ēn	Assignment	Assign relays to channels or Modbus
R5 Ēn 1*	Assign 1	Relay 1 (*through 8) assignment
ĀĒ-R*	Channel A*	Assign relay to channel A (*or B or C)
rĒĒ*	Rate	Assign relay to rate (*channel A and B only)
ĒoĒRĒ*	Total	Assign relay to total (*channel A and B only)
ĀĒoĒRĒ*	Grand total	Assign relay to grand total (*channel A and B only)
rr b5	Modbus	Assign relay to Modbus register
rĒY 1*	Relay 1	Relay 1 (*through 8) setup
RĒĒ 1	Action 1	Set relay 1 action

Display	Parameter	Action/Setting Description
<i>RuLo</i>	<i>Automatic</i>	Set relay for automatic reset
<i>SEt 1</i>	<i>Set 1</i>	Enter relay 1 set point
<i>rSt 1</i>	<i>Reset 1</i>	Enter relay 1 reset point
<i>R-nRn</i>	<i>Auto-manual</i>	Set relay for auto or manual reset any time
<i>LRECH</i>	<i>Latching</i>	Set relay for latching operation
<i>Lt-CLr</i>	<i>Latching-cleared</i>	Set relay for latching operation with manual reset only after alarm condition has cleared
<i>ALtErn</i>	<i>Alternate</i>	Set relay for pump alternation control
<i>SPn PL</i>	<i>Sample</i>	Set relay for sample time trigger control
<i>OFF</i>	<i>Off</i>	Turn relay off
<i>FRILSF</i>	<i>Fail-safe</i>	Enter <i>Fail-safe</i> menu
<i>FLS 1*</i>	<i>Fail-safe 1</i>	Set relay 1 (*through 8) fail-safe operation
<i>on</i>	<i>On</i>	Enable fail-safe operation
<i>oFF</i>	<i>Off</i>	Disable fail-safe operation
<i>dELAY</i>	<i>Delay</i>	Enter relay <i>Time Delay</i> menu
<i>dLY 1*</i>	<i>Delay 1</i>	Enter relay 1 (*through 8) time delay setup
<i>On 1</i>	<i>On 1</i>	Set relay 1 On time delay
<i>OFF 1</i>	<i>Off 1</i>	Set relay 1 Off time delay
<i>brERH</i>	<i>Loop break</i>	Set relay condition if loop break detected
<i>brERH 1*</i>	<i>Break 1</i>	Set relay 1 (*through 8) break condition
<i>IgnorE</i>	<i>Ignore</i>	Ignore loop break condition (Processed as a low signal condition)
<i>On</i>	<i>On</i>	Relay goes to alarm condition when loop break detected
<i>OFF</i>	<i>Off</i>	Relay goes to non-alarm condition when loop break detected
<i>Rout</i>	<i>Analog output</i>	Enter the <i>Analog output</i> scaling menu
<i>Rout 1*</i>	<i>Aout Channel</i>	Analog Output source channel (*1-3)
<i>dS 1</i>	<i>Display 1</i>	Program display 1 value

Display	Parameter	Action/Setting Description
<i>Out 1</i>	<i>Output 1</i>	Program output 1 value (e.g. 4.000 mA)
<i>dS 2</i>	<i>Display 2</i>	Program display 2 value
<i>Out 2</i>	<i>Output 2</i>	Program output 2 value (e.g. 20.000 mA)
<i>rESEt</i>	<i>Reset</i>	Press Enter to access the <i>Reset</i> menu
<i>rSt H 1</i>	<i>Reset high</i>	Press Enter to reset max display
<i>rSt Lo</i>	<i>Reset low</i>	Press Enter to reset min display
<i>rSt HL</i>	<i>Reset high & low</i>	Press Enter to reset max & min displays
<i>tot A</i>	<i>Reset total A</i>	Press Enter to reset channel A total
<i>tot B</i>	<i>Reset total B</i>	Press Enter to reset channel B total
<i>GrOt A</i>	<i>Reset grand total A</i>	Press Enter to reset channel A grand total
<i>GrOt B</i>	<i>Reset grand total B</i>	Press Enter to reset channel B grand total
<i>tot AB</i>	<i>Reset totals A and B</i>	Press Enter to reset channels A and B totals
<i>Gr AB</i>	<i>Reset grand totals A and B</i>	Press Enter to reset channels A and B grand totals
<i>Control</i>	<i>Control</i>	Enter <i>Control</i> menu
<i>RuLo</i>	<i>Automatic</i>	Press Enter to set meter for automatic operation
<i>nRn</i>	<i>Manual</i>	Press Enter to manually control relays or analog output operation
<i>PASS</i>	<i>Password</i>	Enter the <i>Password</i> menu
<i>PASS 1</i>	<i>Password 1</i>	Set or enter Password 1
<i>UnLocH</i>	<i>Unlocked</i>	Program password to lock meter
<i>Locd</i>	<i>Locked</i>	Enter password to unlock meter
<i>PASS 2</i>	<i>Password 2</i>	Set or enter Password 2
<i>PASS 3</i>	<i>Password 3</i>	Set or enter Password 3
<i>totRL</i>	<i>Total reset password</i>	Set or enter a total reset password
<i>GrOtRL</i>	<i>Grand total password</i>	Set or enter a grand total reset password
<i>999999 -999999</i>	<i>Flashing</i>	Over/under range condition

Main Menu

The main menu consists of the most commonly used functions: *Reset, Control, Setup, and Password.*

- Press Menu button to enter Programming Mode then press the Up arrow button to scroll main menu.
- Press Menu, at any time, to exit and return to Run Mode. Changes made to settings prior to pressing Enter are not saved.
- Changes to the settings are saved to memory only after pressing Enter.
- The display moves to the next menu every time a setting is accepted by pressing Enter.

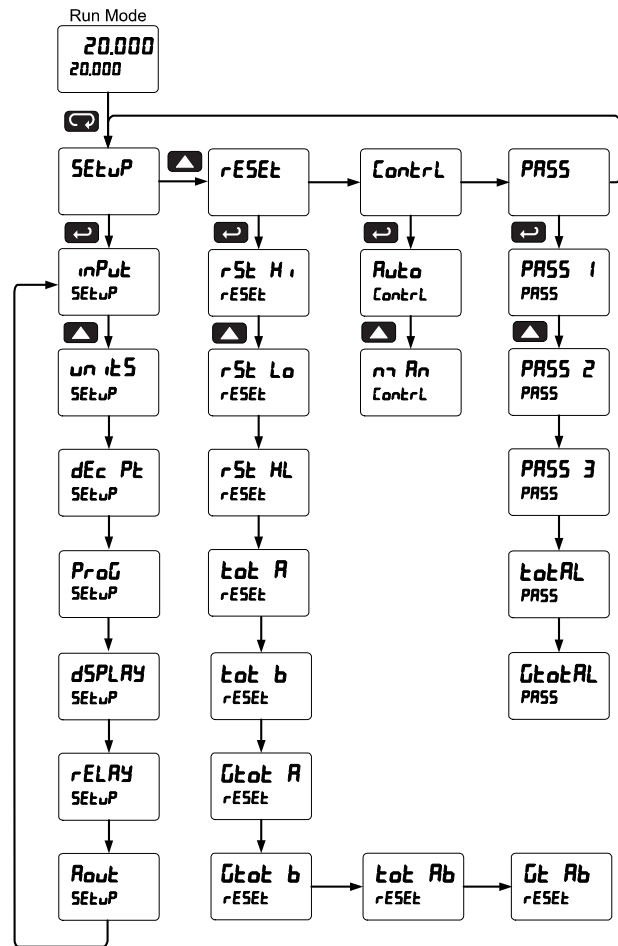

Setting Numeric Values

The numeric values are set using the Right and Up arrow buttons. Press Right arrow to select next digit and Up arrow to increment digit value.

The digit being changed is displayed brighter than the rest.

Press and hold up arrow to auto-increment the display value.

Press the Enter button, at any time, to accept a setting or Menu button to exit without saving changes.

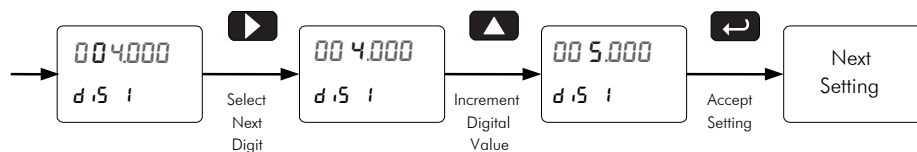

Setting Up the Meter (SEtUP)

The *Setup* menu is used to select:

1. Input signal the meter will accept for channel A and channel B
2. Units for A & B rate, total & grand total, and C
3. Decimal positions for A & B rate, total, and grand total, and C
4. Program the meter using the scale, calibrate, & total functions
5. Display parameters and intensity
6. Relay assignments and operation
7. 4-20 mA analog output scaling

Press the Menu button to exit at any time.

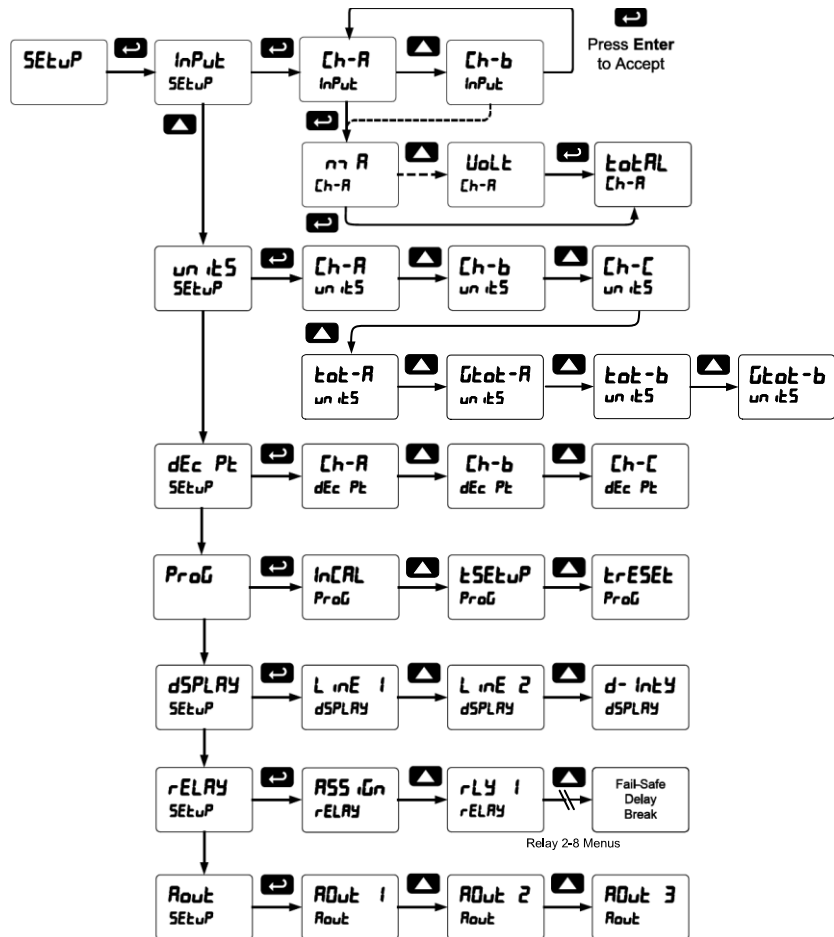

Setting the Input Signal (InPUt)

Enter the *Input* menu to set up the meter to display current (*mA*) or voltage (*VoLT*) inputs for channel A and channel B.

The current input is capable of accepting any signal from 0 to 20 mA. Select current input to accept 0-20 mA or 4-20 mA signals.

The voltage input is capable of accepting any signal from -10 to +10 VDC. Select voltage input to accept 0-5, 1-5, 0-10, or ±10 VDC signals.

Channel C is the Math Function calculation, which is set up in the Advanced Features menu.

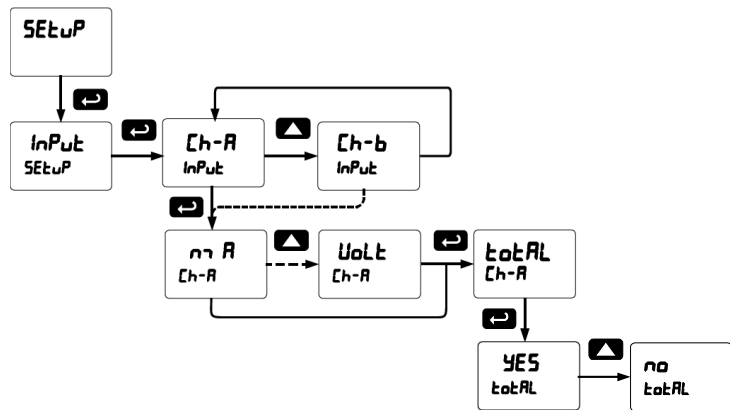

Setting the Totalizer Features (Total)

To simply not display the total, select alternative display parameters in the display (dSPLY) menu.

Enable or disable the totalizer features by selecting “YES” or “no” after the input type has been set up for each channel. If the totalizer features are disabled, all the totalizer features and functions are hidden from the menus. Level and process meter features and functions are added to the menus.

If disabling the Total parameter by selecting no, please refer to the PD6060 manual available at www.predig.com for instructions on setting up the meter parameters.

Notes: 1. The totalizer continues working in the background.

2. When selecting “no” for Total for a channel, the meter now functions as a PD6060 Dual-Input Process Meter for parameters that affect that channel. We strongly suggest that you download and use the PD6060 instruction manual from our website (www.predig.com) while in this mode of operation.

Setting the Rate, Total, & Grand Total Units/Tags (Units)

Enter the channel A and B rate, total, grand total, and math channel C units (or custom tags) that will be displayed if alternating units is selected in the Units menu, or d Units is selected as the lower display parameter.

See the flow chart on page 23 for details on accessing the Units menu and parameters. [h-A and [h-B set the rate units, Total-A and Total-B the total units, and Grand Total-A and Grand Total-B the grand total units. [h-C sets the units for the math channel C.

See the flow chart on page 30 to access the display menu to show the unit or tag on the lower display.

The engineering units or custom legends can be set using the following 7-segment character set:

Display	Character	Display	Character	Display	Character	Display	Character
0	0	C	C	K	K	v	V
1	1	c	c	L	L	w	w
2	2	d	d	m	m	X	X
3	3	E	E	n	n	Y	Y
4	4	F	F	O	O	Z	Z
5	5	G	G	o	o	-	-
6	6	g	g	P	P	/	/
7	7	H	H	q	q	[]
8	8	h	h	r	r	[[
9	9	I	I	S	S	=	=
A	A	i	i	t	t	°	Degree(<)
b	b	J	J	u	u		Space

Notes: Degree symbol represented by (<) if programming with MeterView® Pro. The letters “m” and “w” use two 7-segment LEDs each; when selected the characters to the right are shifted one position.

Press and hold up arrow to auto-scroll the characters in the display.

Setting the Decimal Point (dEc Pt)

The decimal point for any channel, rate, total, or grand total, may be set with up to five decimal places or with no decimal point at all.

Pressing the Right arrow moves the decimal point one place to the right until no decimal point is displayed, and then it moves to the leftmost position. Pressing the Up arrow moves the decimal point one place to the left.

There are seven decimal points to set up for three channels: Ch-A rate, total, and grand total; Ch-B rate, total, and grand total; and Ch-C.

After the decimal points are set up, the meter moves to the *Program* menu.

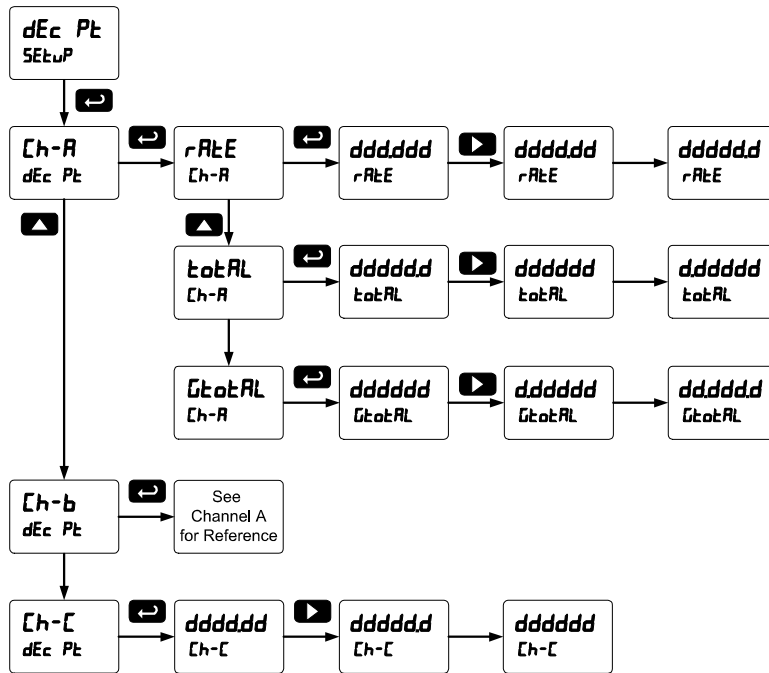

Programming the Rate/Totalizer (Prog)

It is **very important** to read the following information, before proceeding to program the meter:

- The meter is factory calibrated prior to shipment to read in milliamps and volts depending on the input selection. The calibration equipment is certified to NIST standards.
- Use the *Scale* menu to scale the process input (e.g. 4-20 mA). A calibrated signal source is not needed to scale the meter.
- Use the *Calibrate* menu to apply a signal from a calibrator or a flowmeter.

The *Program* menu contains the following menus:

1. Scale channel A and B without a signal source
2. Calibrate channel A and B with a calibrated signal source
3. Channel A and B total time base & conversion factors
4. Channel A and B grand total time base & conversion factors
5. Channel A and B reset modes for total & grand total

The process inputs may be calibrated or scaled to any display value within the range of the meter.

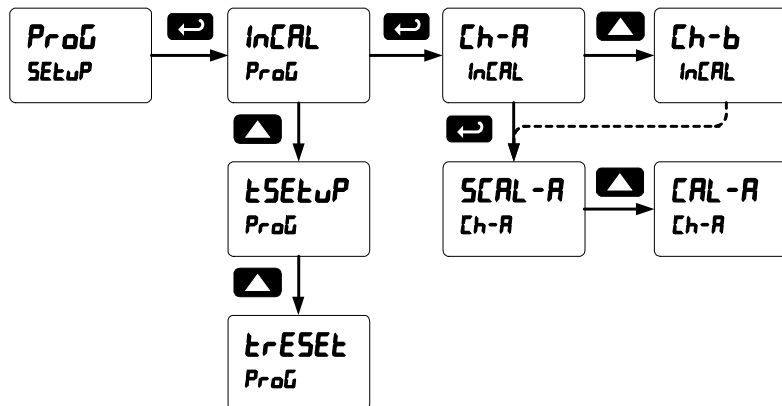

Additional parameters, not needed for most applications, are found in the *Advanced Features* menu; see *Advanced Features Menu*, page 43.

Input Calibration Method (InCAL)

There are two methods of calibrating (or scaling) the display for each input channel to show the correct engineering units.

- Use the *Scale* menu to enter the scaling without a signal source.
- Use the *Calibrate* menu to apply a signal from a signal source.

Note: The Scale and Calibrate functions are exclusive of each other. The meter uses the last function programmed. Only one of these methods can be employed at a time. The Scale and Calibrate functions can use up to 32 points (default is 2). The number of points should be set in Scale and Calibrate accordingly under the Number of Points (nPt5) menu selection prior to scaling and calibration of the meter, see page 47 for details.

Scaling the Meter without a Signal Source (SCAL-A, SCAL-B)

The process inputs (4-20 mA, ±10 VDC) can be scaled to display the process variables in engineering units. A signal source is not needed to scale the meter; simply program the inputs and corresponding display values.

From the *InCAL* menu, select channel A or B, followed by *SCAL-A* or *SCAL-B*, and then set the signal input value and display value for each of the scaling points (default is two).

Scaling the Meter for Channel A (SCAL-A)

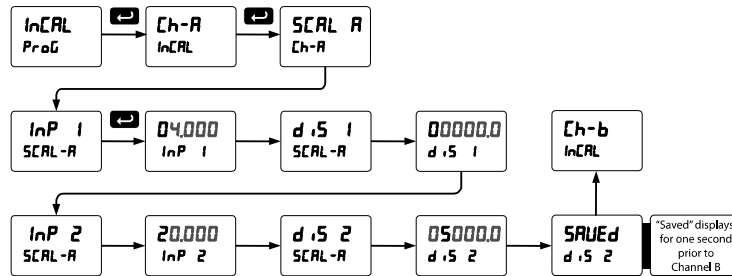

Scaling the Meter for Channel B (SCAL-B)

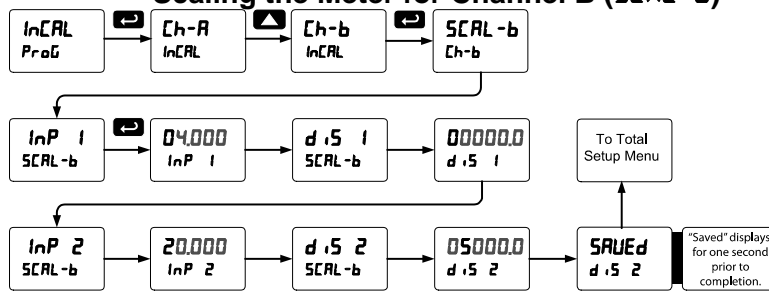

For instructions on how to program numeric values see Setting Numeric Values, page 22.

Error Message (Error)

An error message indicates that the calibration or scaling process was not successful.

After the error message is displayed, the meter reverts to input 2 during calibration or scaling and to input 1 during internal calibration, allowing the appropriate input signal to be applied or programmed.

The error message might be caused by any of the following conditions:

1. Input signal is not connected to the proper terminals or it is connected backwards.
2. Wrong signal selection in *Setup* menu.
3. Minimum input span requirements not maintained.
4. Input 1 signal inadvertently applied to calibrate input 2.

Minimum Input Span

The minimum input span is the minimum difference between input 1 and input 2 signals required to complete the calibration or scaling of the meter.

Input Range	Input 1 & Input 2 Span
4-20 mA	0.15 mA
±10 VDC	0.01 VDC

Calibrating the Meter with External Source

To scale the meter without a signal source, refer to Scaling the Meter without a Signal Source (5CAL -A, 5CAL -b), page 27.

Warm up the meter for at least 15 minutes before performing calibration to ensure specified accuracy.

The meter can be calibrated to display the process variables in engineering units by applying the appropriate input signal and following the calibration procedure.

The use of a calibrated signal source is strongly recommended to calibrate the meter.

Calibrating the Meter for Channel A (CAL -A)

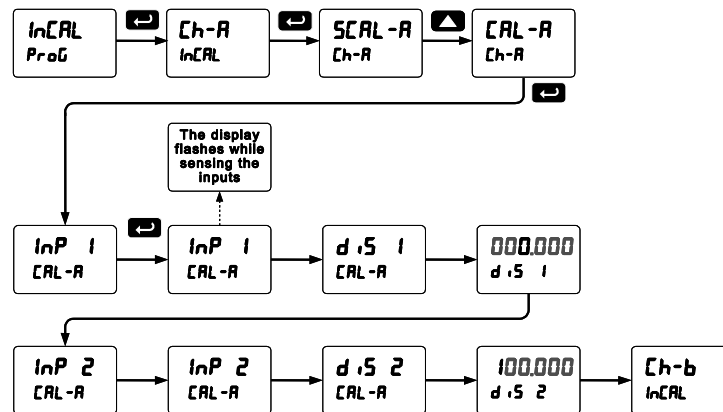

Calibrating the Meter for Channel B (CAL -b)

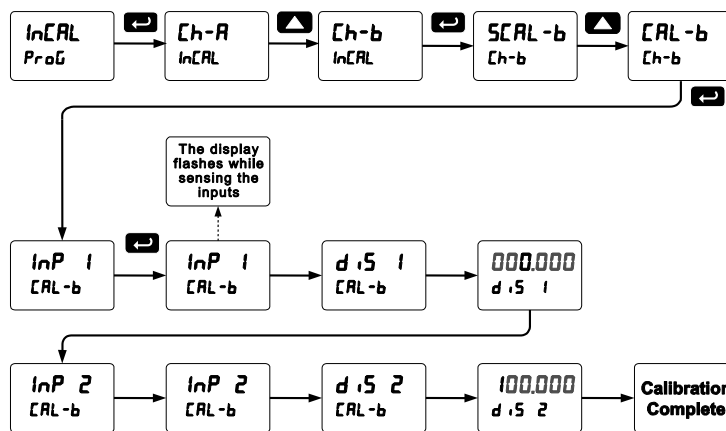

Total and Grand Total Setup

The time base and total conversion factor, and grand total conversion factor for input channels A and B are located in the *Totalizer Setup* menu.

The time base is based on the rate of flow. Total & grand total conversion factors for channel A and B are programmed independently. The total and grand total have their own independent settings. This means that one can be displaying the value in gallons while the other displays in million gallons, liters, m³, etc.

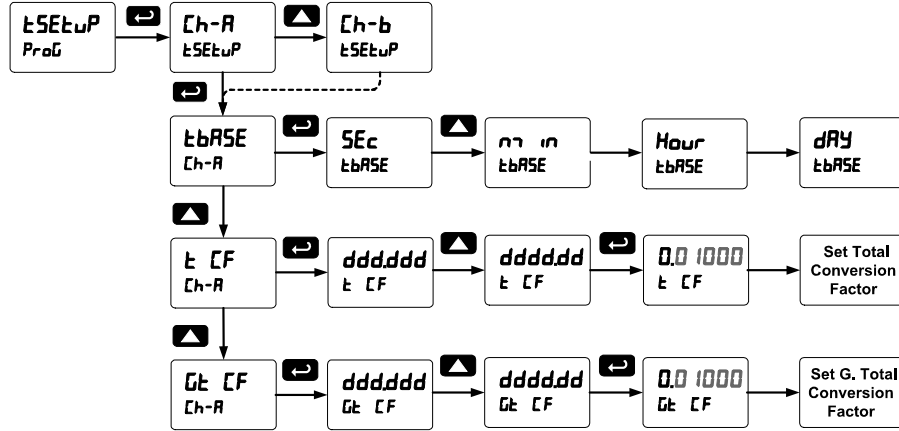

Total & Grand Total Reset

Total reset menus are located in the *Program* menu. The totals can be programmed for manual or automatic reset. In the automatic reset mode, a programmable time delay is available to reset the total or grand total after the assigned preset is reached.

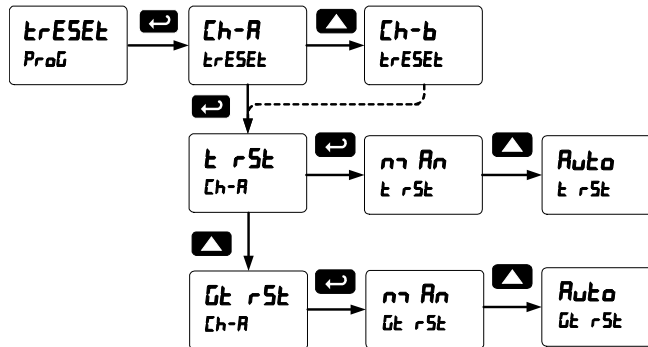

Password Protected and Non-Resettable Total

The total and grand total can be password-protected to prevent unauthorized resets. The grand total can be programmed as a non-resettable total, see page 42 for details.

Setting the Display Parameters & Intensity (dSPRAY)

Display line 1 (LINE 1) can be programmed to display:

1. Ch-A rate (d [h-A])
2. Ch-B rate (d [h-b])
3. Ch-C math channel (d [h- Σ])
4. Toggle Ch-A & Ch-B rate (d Rb)
5. Toggle Ch-A rate and Ch-C (d R Σ)
6. Toggle Ch-B rate and Ch-C (d b Σ)
7. Toggle Ch-A & Ch-B rate, and Ch-C (d Rb Σ)
8. Ch-A total (d t-A)
9. Ch-B total (d t-b)
10. Ch-A grand total (d Σ t-A)
11. Ch-B grand total (d Σ t-b)
12. Toggle Ch-A rate and total (d r t-A)
13. Toggle Ch-B rate and total (d r t-b)
14. Toggle Ch-A rate and grand total (d r Σ t-A)
15. Toggle Ch-B rate and grand total (d r Σ t-b)
16. Relay set points (1-8) (dSEt 1 to dSEt 8)
17. Max, min, and max & min values for Ch-A, Ch-B, or Ch-C (d H r-A to d HL- Σ)
18. Toggle Ch-A rate & units (d R-u)
19. Toggle Ch-B rate & units (d b-u)
20. Toggle Ch-C & units (d Σ -u)
21. Toggle Ch-A total & units (d tR-u)
22. Toggle Ch-B total & units (d tb-u)
23. Toggle Ch-A total and Ch-B total (d tRb)
24. Toggle Ch-A total, Ch-B total, and the sum of total A and total B (d tRb Σ).

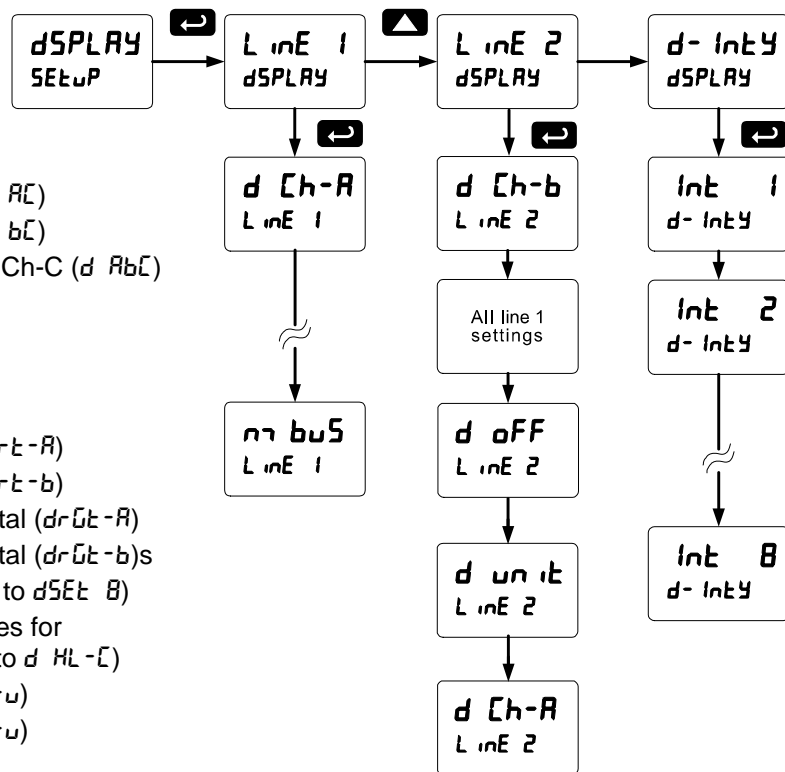

Notes: The sum of total A and B for t ABC is independent of channel C programming. Channel C may be used normally by a different display selection even when d tRb Σ is selected for one of the two displays.

25. Modbus input (r r b u S)

Display line 2 (LINE 2) can be programmed to display:

1. All options for display line 1
2. Off, with no display (d OFF)
3. Engineering units for any single channel, total, or grand total

Display Intensity: The meter has eight display intensity levels to give the best performance under various lighting conditions. Select intensity 8 for outdoor applications. The default intensity setting is 8.

After setting up the input and display, press the Menu button to exit programming and skip the rest of the setup menu.

Setting the Relay Operation (rELAY)

This menu is used to set up the assignment and operation of the relays.



Caution! During setup, the relays do not follow the input and they will remain in the state found prior to entering the Relay menu.

1. Relay assignment
 - a. Channel A rate, total, or grand total
 - b. Channel B rate, total, or grand total
 - c. Channel C (Math channel)
 - d. Modbus
2. Relay action
 - a. Automatic reset only (non-latching)
 - b. Automatic + manual reset at any time (non-latching)
 - c. Latching (manual reset only)
 - d. Latching with Clear (manual reset only after alarm condition has cleared)
 - e. Pump alternation control (automatic reset only)
 - f. Sampling (the relay is activated for a user-specified time)
 - g. Off (relay state controlled by Interlock feature)
3. Set point
4. Reset point
5. Fail-safe operation
 - a. On (enabled)
 - b. Off (disabled)
6. Time delay
 - a. On delay (0-999.9 seconds)
 - b. Off delay (0-999.9 seconds)
7. Relay action for loss (break) of 4-20 mA input (ignore, on, off)

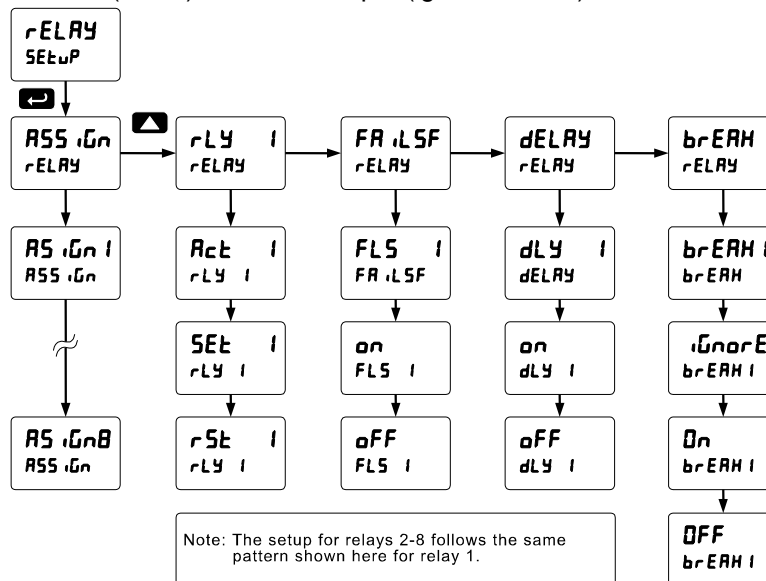

Setting the Relay Assignment (RSS, rELRY)

Relays may be assigned to Channel A (rate, total, or grand total), Channel B (rate, total, or grand total), Channel C (Math channel), or Modbus input.

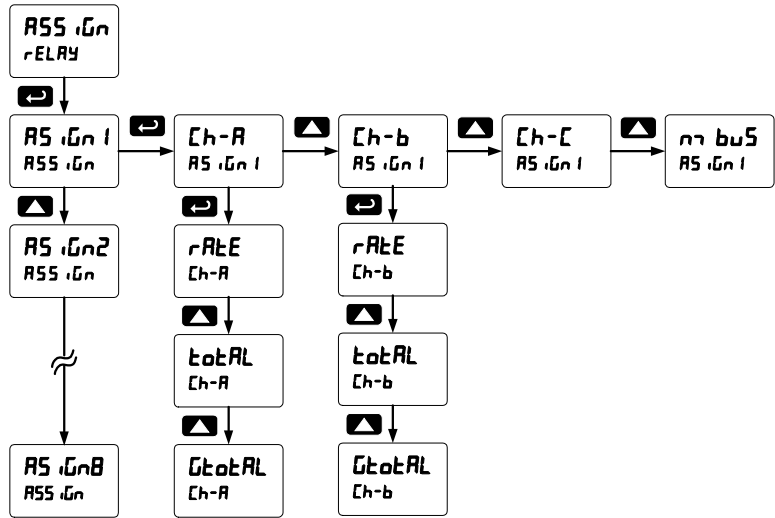

Setting the Relay Action (Act)

Operation of the relays is programmed in the *Action* menu. The relays may be set up for any of the following modes of operation:

1. Automatic reset (non-latching)
2. Automatic + manual reset at any time (non-latching)
3. Latching (manual reset only, at any time)
4. Latching with Clear (manual reset only after alarm condition has cleared)
5. Pump alternation control (automatic reset only)
6. Sampling (the relay is activated for a user-specified time)
7. Off (relay state controlled by Interlock feature)

The following graphic shows relay 1 action setup; relay 2-8 are set up in a similar fashion.

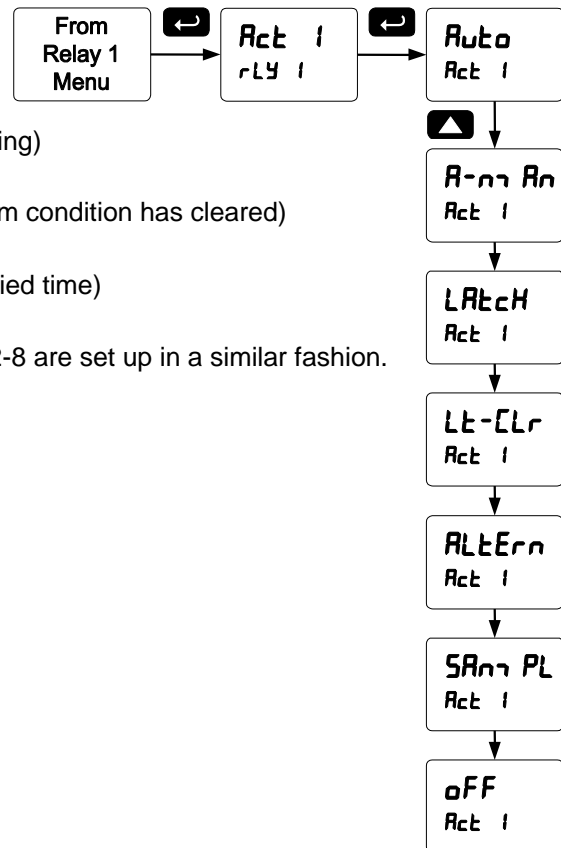

Programming Set and Reset Points

High alarm indication: program set point above reset point.

Low alarm indication: program set point below reset point.

The deadband is determined by the difference between set and reset points. Minimum deadband is one display count. If the set and reset points are programmed with the same value, the relay will reset one count below the set point.

Note: Changes are not saved until the reset point has been accepted.

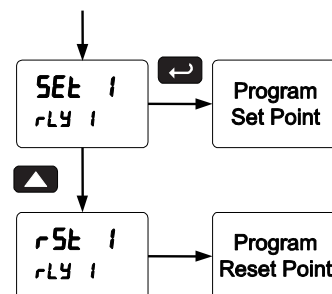

Setting Fail-Safe Operation

In fail-safe mode of operation, the relay coil is energized when the process variable is within safe limits and the relay coil is de-energized when the alarm condition exists. The fail-safe operation is set independently for each relay. Select **on** to enable or select **oFF** to disable fail-safe operation.

Programming Time Delay

The *On* and *Off* time delays may be programmed for each relay between 0 and 999.9 seconds. The relays will transfer only after the condition has been maintained for the corresponding time delay.

The *On* time delay is associated with the set point.

The *Off* time delay is associated with the reset point.

Relay Action for Loss of 4-20 mA Input (Loop Break)

The loop break feature is associated with the 4-20 mA input. Each relay may be programmed to go to one of the following conditions when the meter detects the loss of the input signal (i.e. < 0.005 mA):

1. Turn *On* (Go to alarm condition)
2. Turn *Off* (Go to non-alarm condition)
3. Ignore (Processed as a low signal condition)

Note: This is not a true loop break condition; if the signal drops below 0.005 mA, it is interpreted as a "loop break" condition.

Relay and Alarm Operation Diagrams

The following graphs illustrate the operation of the relays, status LEDs, and ACK button.

High Alarm Operation (Set > Reset)

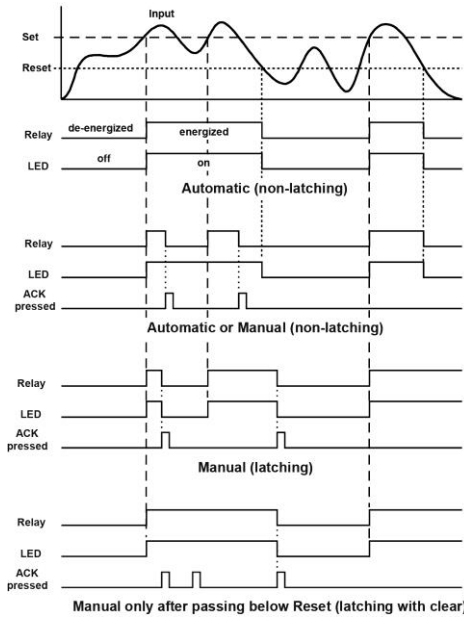

For Manual reset mode, ACK can be pressed anytime to turn "off" relay. To detect a new alarm condition, the signal must go below the set point, and then go above it.

Low Alarm Operation (Set < Reset)

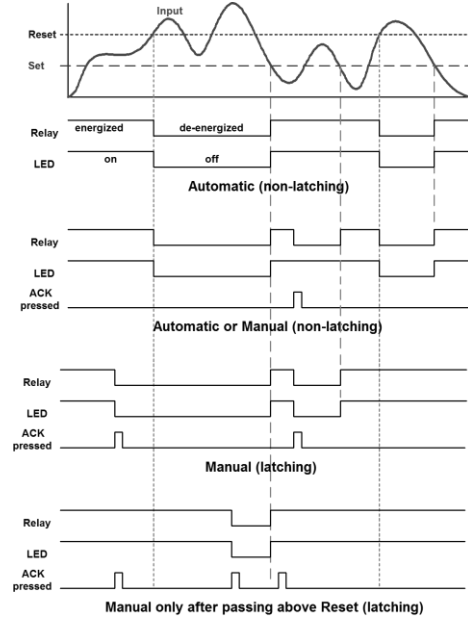

For Manual reset mode, ACK can be pressed anytime to turn "off" relay. For relay to turn back "on", signal must go above set point and then go below it.

High Alarm with Fail-Safe Operation (Set > Reset)

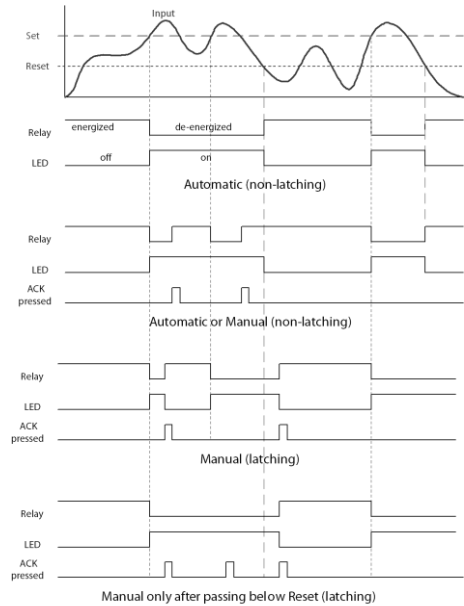

Note: Relay coil is energized in non-alarm condition. In case of power failure, relay will go to alarm state.

Low Alarm with Fail-Safe Operation (Set < Reset)

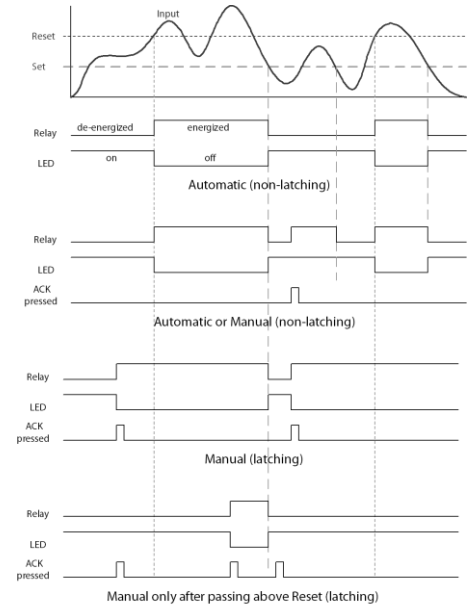

Note: Relay coil is energized in non-alarm condition. In case of power failure, relay will go to alarm state.

Pump Alternation Control Operation

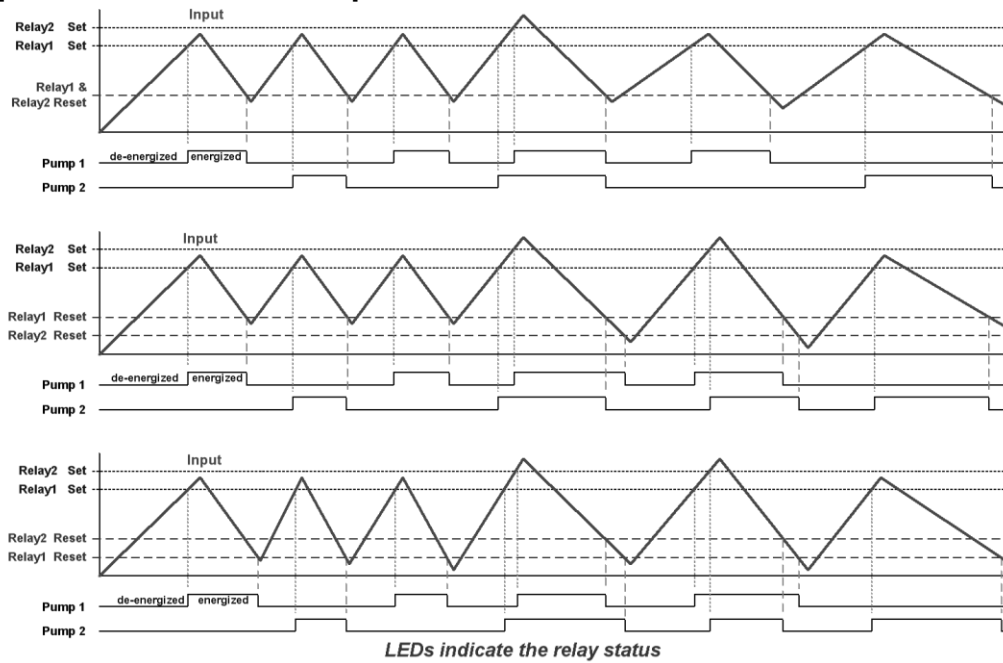

Relay Sampling Operation

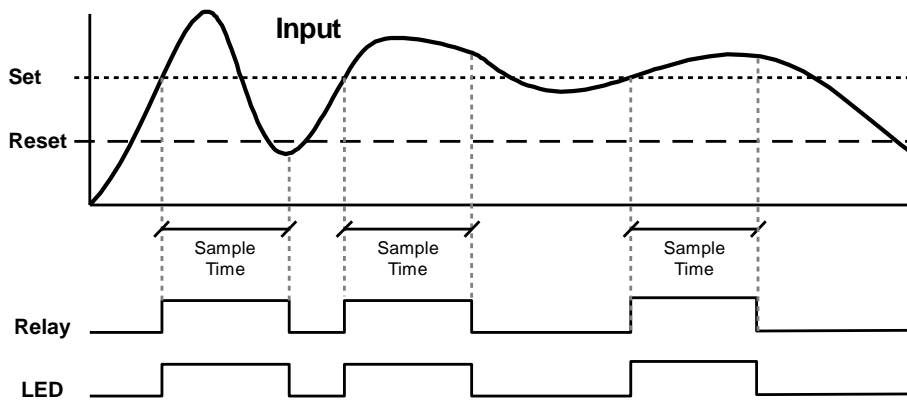

When the signal crosses the set point, the relay trips and the sample time starts. After the sample time has elapsed, the relay resets. The cycle repeats every time the set point is crossed, going up for high alarms and going down for low alarms.

The sample time can be programmed between 0.1 and 5999.9 seconds.

Signal Loss or Loop Break Relay Operation

The following graph shows the loop break relay operation for a high alarm relay.

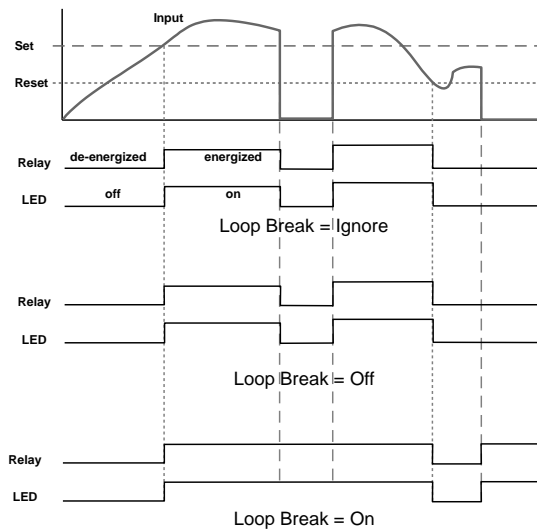

When the meter detects a break in the 4-20 mA loop, the relay will go to one of the following selected actions:

1. Turn On (Go to alarm condition)
2. Turn Off (Go to non-alarm condition)
3. Ignore (Processed as a low signal condition)

Time Delay Operation

The following graphs show the operation of the time delay function.

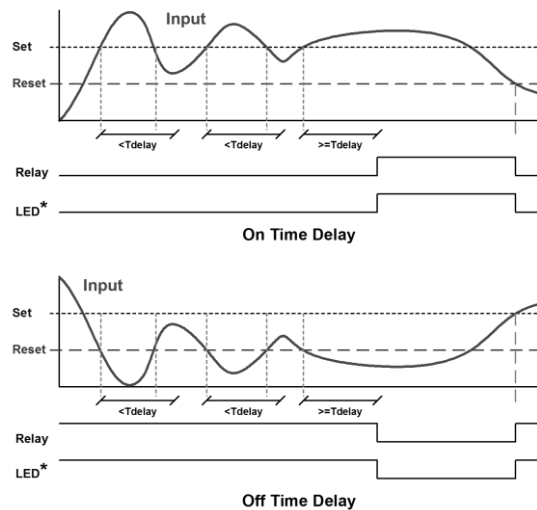

When the signal crosses the set point, the *On* time delay timer starts and the relay trips when the time delay has elapsed. If the signal drops below the set point (high alarm) before the time delay has elapsed, the *On* time delay timer resets and the relay does not change state. The same principle applies to the *Off* time delay.

Note: If "Automatic or Manual (R-n Rn)" reset mode is selected, the LED follows the reset point and not the relay state when the relay is acknowledged.

Relay Operation Details

Overview

The relay capabilities of the meter expand its usefulness beyond simple indication to provide users with alarm and control functions. These capabilities include front panel alarm status LEDs as well as either 2 or 4 optional internal relays and/or 4 external relays expansion module. Typical applications include high or low temperature, level, pressure or flow alarms, control applications such as simple on/off pump control, and pump alternation control for up to 8 pumps. There are four basic ways the relays can be used:

1. High or Low Alarms with Latching or Non-Latching Relays
2. Simple On/Off Control with 100% Adjustable Deadband
3. Sampling (Based on Time)
4. Pump Alternation Control for up to 8 Pumps

Relays Auto Initialization

When power is applied to the meter, the front panel LEDs and alarm relays will reflect the state of the input to the meter. The following table indicates how the alarm LEDs and relays will react on power-up based on the set and reset points:

Alarm #	HI or LO Alarm	Set Point	Reset Point	Power-Up Reading	Relay & LED
1	HI	1000	500	499	Off
2	LO	700	900	499	On
3	LO	250	400	499	Off
4	HI	450	200	499	On

Fail-Safe Operation

The following table indicates how the relays behave based on the fail-safe selection for each relay:

Note: NO = Normally Open, NC = Normally Closed. This refers to the condition of the relay contacts when the power to the meter is off.

Fail-Safe Selection	Non-Alarm State		Alarm State		Power Failure
	NO	NC	NO	NC	
Off	Open	Closed	Closed	Open	Relays go to non-alarm state
On	Closed	Open	Open	Closed	Relays go to alarm state

Front Panel LEDs

The LEDs on the front panel provide status indication for the following:

The meter is supplied with four alarm points that include front panel LEDs to indicate alarm conditions. This standard feature is particularly useful for alarm applications that require visual-only indication. The LEDs are controlled by the set and reset points programmed by the user. When the display reaches a set point for a high or low alarm, the corresponding alarm LED will turn on. When the display returns to the reset point the LED will go off. The front panel LEDs responds differently for latching and non-latching relays.

LED	Status
1	Alarm 1
2	Alarm 2
3	Alarm 3
4	Alarm 4

LED	Status
5	Alarm 5
6	Alarm 6
7	Alarm 7
8	Alarm 8

For non-latching relays, the LED is always off during normal condition and always on during alarm condition, regardless of the state of the relay (e.g. Relay acknowledged after alarm condition).

For latching relays, the alarm LEDs reflects the status of the relays, regardless of the alarm condition. The following tables illustrate how the alarm LEDs function in relation to the relays and the acknowledge button (Default: F3 key assigned to ACK).

Latching and Non-Latching Relay Operation

The relays can be set up for latching (manual reset) or non-latching (automatic reset) operation.

The On and Off terminology does not refer to the status of the relay's coil, which depends on the fail-safe mode selected.

Relay terminology for following tables	
Terminology	Relay Condition
On	Alarm (Tripped)
Off	Normal (Reset)
Ack	Acknowledged



Warning! *In latching relay mode, latched relays will reset (unlatch) when power is cycled.*

Non-Latching Relay (RULC)

In this application, the meter is set up for automatic reset (non-latching relay). Acknowledging the alarm while it is still present has no effect on either the LED or the relay. When the alarm finally goes away, the relay automatically resets and the LED also goes off.

Automatic reset only		
Condition	LED	Relay
Normal	Off	Off
Alarm	On	On
Ack (No effect)	On	On
Normal	Off	Off

Non-Latching Relay (R-n Rn)

In this application, the meter is set up for automatic and manual reset at any time (non-latching relay). The LED and the relay automatically reset when the meter returns to the normal condition.

The next time an alarm occurs, the operator acknowledges the alarm manually while the alarm condition still exists. This causes the relay to reset, but the LED stays on until the meter returns to the normal condition.

Automatic + manual reset at any time		
Condition	LED	Relay
Normal	Off	Off
Alarm	On	On
Normal	Off	Off
Next Alarm	On	On
Ack	On	Off
Normal	Off	Off

Latching Relay (LRLCH)

In this application, the meter is set up for manual reset at any time. Acknowledging the alarm even if the alarm condition is still present resets the relay and turns off the LED.

Manual reset any time		
Condition	LED	Relay
Normal	Off	Off
Alarm	On	On
Ack	Off	Off

Latching Relay (Ll-LLr)

In this application, the meter is set up for manual reset only after the signal passes the reset point (alarm condition has cleared). Acknowledging the alarm while it is still present has no effect on either the LED or the relay. When the alarm is acknowledged after it returns to the normal state, the LED and the relay go off. Notice that the LED remains on, even after the meter returns to the normal condition. This is because, for latching relays, the alarm LED reflects the status of the relay, regardless of the alarm condition.

Manual reset only after alarm condition has cleared		
Condition	LED	Relay
Normal	Off	Off
Alarm	On	On
Ack (No effect)	On	On
Normal	On	On
Ack	Off	Off

Acknowledging Relays

There are two ways to acknowledge relays programmed for manual reset:

1. Via the programmable front panel function keys F1-F3 (Default: F3 assigned to ACK).
2. Remotely via a normally open pushbutton wired across one of the digital inputs and the +5 V terminals on the digital I/O modules, or using the F4 digital input, which is triggered with a contact closure to COM, or with an active low signal (see page 15).

When the ACK button or the assigned digital input is closed, all relays programmed for manual reset are acknowledged.

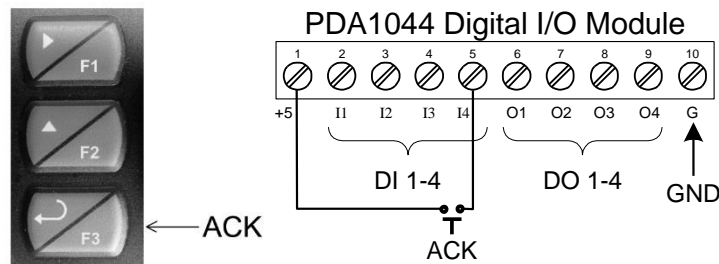

Figure 17. Acknowledge Relays w/Function Key or Digital Input

Pump Alternation Control Applications (RLLErrn)

For pump control applications where two or more similar pumps are used to control the level of a tank or a well, it is desirable to have all the pumps operate alternately. This prevents excessive wear and overheating of one pump over the lack of use of the other pumps.

Up to 8 relays can be set up to alternate every time an on/off pump cycle is completed. The set points and reset points can be programmed, so that the first pump on is the first pump off.

Application #1: Pump Alternation Using Relays 1 & 2

1. Relays 1 and 2 are set up for pump alternation.
2. Relays 3 and 4 are set up for low and high alarm indication.

Set and Reset Point Programming with Pump Alternation

Relay	Set Point	Reset Point	Function
1	30.000	10.000	Controls pump 1 & 2
2	35.000	5.000	Sets dual pump trigger
3	4.000	9.000	Controls low alarm
4	40.000	29.000	Controls high alarm

Pump Alternation Operation

1. Pump #1 turns on when level reaches 30.000, when level drops below 10.000 pump #1 turns off.
2. The next time level reaches 30.000, pump #2 turns on, when level drops below 10.000, pump #2 turns off.
3. If the level doesn't reach 35.000 pump #1 and pump #2 will be operating alternately.
4. If pump #1 cannot keep the level below 35.000 pump #2 will turn on at 35.000, then as the level drops to 10.000 pump #1 turns off, pump #2 is still running and shuts off below 5.000.
5. Notice that with the set and reset points of pump #2 outside the range of pump #1, the first pump on is the first pump to go off. This is true for up to 8 alternating pumps, if setup accordingly.
6. Relay #3 will go into alarm if the level drops below 4.000 and relay #4 will go into alarm if the level exceeds 40.000.
7. Adding the 4 external relays expansion module allows using the 4 SPDT internal relays for pump alternation and the 4 SPST external relays for high, high-high, low, and low-low alarm indication.

Setting Up the Interlock Relay (Force On) Feature

Relays 1-4 can be set up as interlock relays. To set up the relays for the interlock feature:

1. Access the *Setup – Relay – Action* menu and set the action to off.
2. In the Advanced features – *User* menu program any of the digital inputs to *Force On* any of the internal relays (1-4).
3. Connect a switch or dry contact between the +5V terminal and the corresponding digital input (dI-1 to dI-4) terminal.

Note: If multiple digital inputs are assigned to the same relay, then the corresponding logic is (AND) – i.e. both switches must be closed to trip the relay.

Scaling the 4-20 mA Analog Output (Rout)

The 4-20 mA analog outputs can be scaled to provide a 4-20 mA signal for any display range selected. To select the channel and source assignments the analog outputs are assigned to, see *Analog Output Source* on page 50.

No equipment is needed to scale the analog outputs; simply program the display values to the corresponding mA output signal.

The *Analog Output* menu is used to program the 4-20 mA outputs based on display values.

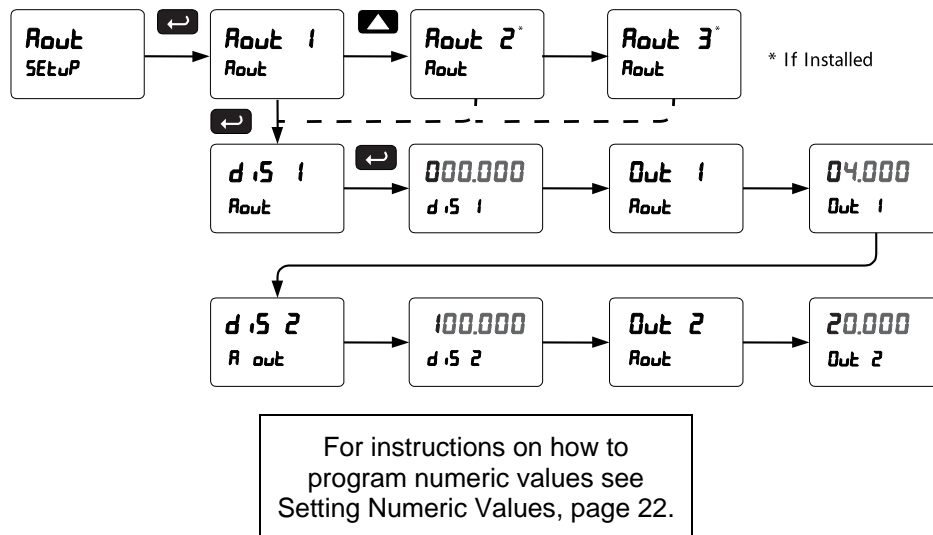

Reset Menu (rESEt)

The *Reset* menu is used to reset the maximum (peak) value of Ch-A and Ch-B rate (r5t H i), minimum (valley) reading of Ch-A and Ch-B rate (r5t L o), both high and low value of Ch-A and Ch-B rate (r5t H L), Ch-A total (t o t A) or Ch-B total (t o t b), Ch-A grand total (G t o t A) or Ch-B grand total (G t o t b), both Ch-A and Ch-B totals (t o t A b), or both Ch-A and Ch-B grand totals (G t A b).

Control Menu (C o n t r L)

The *Control* menu is used to control the 4-20 mA analog output (Aout 1 only) and the relays manually, ignoring the input. Each relay and analog output can be programmed independently for manual control. Selecting automatic control sets all relays and analog output for automatic operation.

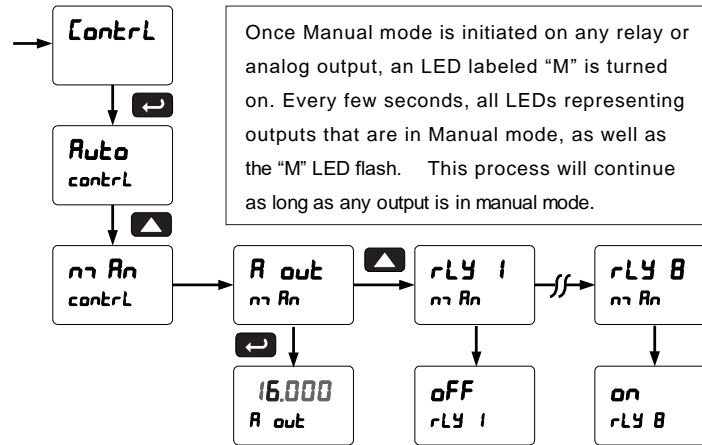

Setting Up the Password (P ASS)

The *Password* menu is used for programming three levels of security to prevent unauthorized changes to the programmed parameter settings, to restrict the ability to reset the totals and grand totals, and to program the non-resettable totalizer.

- Pass 1: Allows use of function keys and digital inputs
- Pass 2: Allows use of function keys, digital inputs and editing set/reset points
- Pass 3: Restricts all programming, function keys, and digital inputs.
- Total: Prevents resetting the total manually
- Gtotal: Prevents resetting the grand total manually

Protecting or Locking the Meter Functions

Enter the *Password* menu and program a six-digit password.

For instructions on how to program numeric values see Setting Numeric Values, page 22.

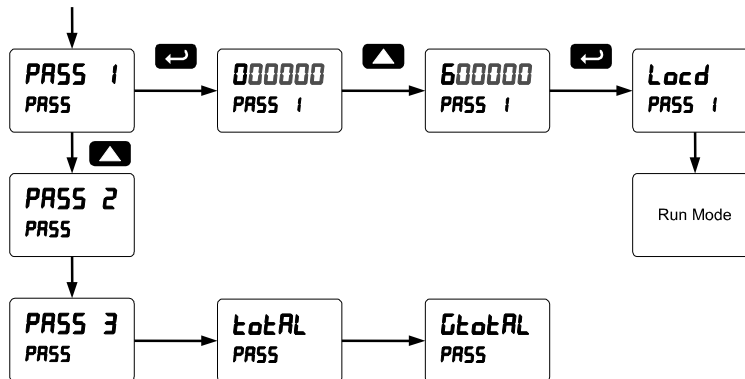

Total Reset Password & Non-Resettable Total

The total and the grand total can be password-protected to prevent unauthorized total resets. The grand total can be programmed as a non-resettable total by entering the password "050873".



Caution! Once the Grand Total has been programmed as "non-resettable" the feature **cannot** be disabled.

Making Changes to a Password Protected Meter

If the meter is password protected, the meter will display the message *Locd* (Locked) when the Menu button is pressed. Press the Enter button while the message is being displayed and enter the correct password to gain access the menu. After exiting the programming mode, the meter returns to its password protected condition.

Disabling Password Protection

To disable the password protection, access the *Password* menu and enter the correct password twice, as shown below. The meter is now unprotected until a new password is entered.

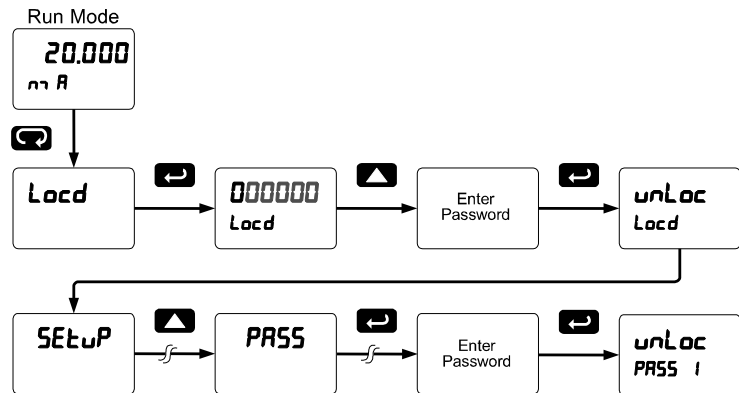

If the correct six-digit password is entered, the meter displays the message *unLoc* (unlocked) and the protection is disabled until a new password is programmed.

If the password entered is incorrect, the meter displays the message *Locd* (Locked) for about two seconds, and then it returns to Run Mode. To try again, press Enter while the *Locked* message is displayed.

Did you forget the password?

The password may be disabled by entering a master password once. If you are authorized to make changes, enter the master password 508655 to unlock the meter.

Advanced Features Menu

To simplify the setup process, functions not needed for most applications are located in the *Advanced Features* menu.

Press and hold the Menu button for three seconds to access the advanced features of the meter.

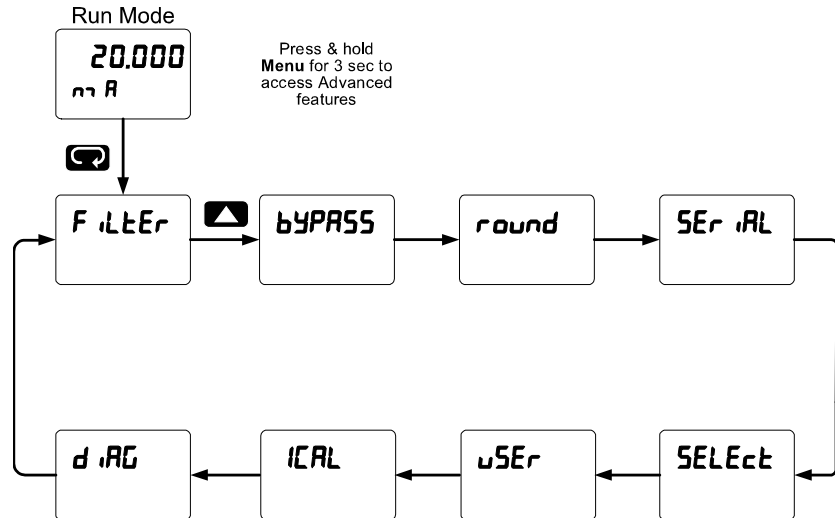

Advanced Features Menu & Display Messages

The following table shows the functions and messages of the *Advanced Features* menu in the order they appear in the menu.

Display	Parameter	Action/Setting
F iLteR	Filter	Set noise filter value
[h-A	Channel A	Set filter value for channel A
[h-b	Channel B	Set filter value for channel B
bYPASS	Bypass	Set filter bypass value
[h-A	Channel A	Set filter bypass value for channel A
[h-b	Channel B	Set filter bypass value for channel B
round	Round	Set the rounding value for display variables
SErIAL	Serial	Set serial communication parameters
SLAVE id	Slave ID	Set slave ID or meter address
baud	Baud rate	Select baud rate
tr dLY	Transmit delay	Set transmit delay for serial communication
PAR itY	Parity	Select parity Even, Odd, or None with 1 or 2 stop bits
t-bytE	Time byte	Set byte-to-byte timeout

Display	Parameter	Action/Setting
SELEct	Select	Enter the Select menu (function, cutoff, out)
Function	Signal input conditioning	Select linear, square root, programmable exponent, or round horizontal tank function
[h-A	Channel A	Select menu for channel A
[h-b	Channel B	Select menu for channel B
LINEAR	Linear	Set meter for linear function and select number of linearization points
no Pts	Number of points	Set the number of linearization points (default: 2)
SqurRE	Square root	Set meter for square root extraction
ProG E	Programmable exponent	Set meter for programmable exponent and enter exponent value
math	Math	Enter the setup menu for channel C math functions

Display	Parameter	Action/Setting
Sum	Sum	$C = (A+B+P)*F$
dif	Difference	$C = (A-B+P)*F$
difAbs	Absolute difference	$C = ((\text{Absolute value of } (A-B))+P)*F$
Avg	Average	$C = (((A+B)/2)+P)*F$
Mult	Multiplication	$C = ((A*B)+P)*F$
Div	Divide	$C = ((A/B)+P)*F$
Max	Max of A or B	$C = ((\text{High value of channel A or B})+P)*F$
Min	Min of A or B	$C = ((\text{Low value of channel A or B})+P)*F$
Draw	Draw	$C = ((A/B)-1)*F$
WtAvg	Weighted avg.	$C = ((B-A)*F)+A$
Ratio	Ratio	$C = (A/B)*F$
Ratio2	Ratio 2	$C = ((B-A)/A)+P)*F$
Conc	Concentration	$C = (A/(A+B))*F$
SumT	Sum total	$C = (tA+tB+P)*F$
SumGT	Sum grand total	$C = (GtA+GtB+P)*F$
difT	Difference of total	$C = (tA-tB+P)*F$
difGT	Diff. of grand total	$C = (GtA-GtB+P)*F$
TotalRatio	Total ratio	$C = (tA/tB)*F$
TotalRatio2	Total ratio 2	$C = ((tB-tA)/tA)*F$
TotalPct	Total percent	$C = (tA/(tA+tB))*100$
Const	Constant	Enter math equation constants
Adder	Adder	Addition constant used in channel C math calculations (P)
Factor	Factor	Multiplication constant used in channel C math calculations (F)
Cutoff	Cutoff	Set low-flow cutoff
Ch-A	Channel A	Set low-flow cutoff for Channel A
Ch-B	Channel B	Set low-flow cutoff for Channel B
Count	Count	Set total count direction

Display	Parameter	Action/Setting
Ch-A	Channel A	Set total count direction for Channel A
Ch-B	Channel B	Set total count direction for Channel B
TotalC	Total count	Set direction of total count
GrandTotalC	Grand total count	Set direction of grand total count
Up	Count up	Count up
Down	Count down	Count down
CountStart	Count start	Enter count down start value
AnalogPr	Analog output programming	Program analog output parameters
AnalogOut1	Analog output 1	Program analog output 1 (*1-3) parameters
Source	Source	Select source for the 4-20 mA output
LoopBreak	Loop break	Set analog output if loop break detected
Calibrate	Calibrate	Calibrate 4-20 mA output (internal reference source used for scaling the output)
4mA	4 mA output	Enter mA output value read by milliamp meter with at least 0.001 mA resolution
20mA	20 mA output	Enter mA output value read by milliamp meter with at least 0.001 mA resolution
Overrange	Overrange	Program mA output for display overrange
Underrange	Underrange	Program mA output for display underrange
Maximum	Maximum	Program maximum mA output allowed
Minimum	Minimum	Program minimum mA output allowed
UserI/O	User I/O	Assign function keys and digital I/O

Display	Parameter	Action/Setting
F 1*	F1* function key	Assign F1 function key (*F1/F2/F3)
F4	F4 digital input	Assign F4 function (digital input)
d i 1	Digital input 1	Assign digital input 1 – 8, if expansion modules are connected
d O 1	Digital output 1	Assign digital output 1 – 8, if expansion modules are connected
iCAL	Internal calibration	Enter internal calibration (used for recalibrating the meter with a calibrated signal source)
Ch-A	Channel A	Perform calibration on channel A
Ch-B	Channel B	Perform calibration on channel B

Display	Parameter	Action/Setting
CL	Current calibration	Calibrate 4-20 mA current input (internal reference source used for scaling the input)
CLo	Current low	Calibrate low current input (e.g. 4 mA)
CHi	Current high	Calibrate high current input (e.g. 20 mA)
U CAL	Voltage calibration	Calibrate voltage input
ULo	Voltage low	Calibrate low voltage input (e.g. 0 V)
UHi	Voltage high	Calibrate high voltage input (e.g. 10 V)
d iRG	Diagnostics	Display parameter settings
LEd t	LED test	Test all LEDs
Info	Information	Display software and S/N information
ErASE	Erase	Erase MeterView Pro software stored in meter's memory

Noise Filter (FILTFR)

The noise filter is available for unusually noisy signals that cause an unstable process variable display. The noise filter averages the input signal over a certain period. The filter level determines the length of time over which the signal is averaged. The filter level can be set between 2 and 199. The higher the filter level, the longer the averaging time and so the longer it takes the display to settle to its final value. Setting the filter level to zero disables the filter function.

Noise Filter Bypass (bypass)

The noise filter bypass changes the behavior of the meter so that small variations in the signal are filtered out but large abrupt changes in the input signal are displayed immediately. The bypass value determines the minimum amount of signal change to be displayed immediately. All signal changes smaller than the bypass value are filtered or averaged by the meter. The noise filter bypass may be set between 0.1 and 99.9% of full scale.

Rounding Feature (round)

The rounding feature is used to give the user a steadier display with fluctuating signals. Rounding is used in addition to the filter function.

Rounding causes the display to round to the nearest value according to the rounding selected. This setting affects the last two digits, regardless of decimal point position.

Modbus RTU Serial Communications (SErIAL)

The meter is equipped with serial communications capability as a standard feature using Modbus RTU Serial Communication Protocol.

The meter may be connected to a PC for initial configuration via the onboard micro USB connection. For ongoing digital communications with a computer or other data terminal equipment, an RS-232, or RS-485 option is required; see *Ordering Information* on page 5 for details.



Warning! Do not connect any equipment other than Precision Digital's expansion modules, cables, or meters to the RJ45 M-LINK connector. Otherwise damage will occur to the equipment and the meter.

Note: More detailed instructions are provided with each optional serial communications adapter.

Note: Refer to the ProVu® Modbus Register Tables located at www.predig.com for details.

When using more than one meter in a multi-drop mode, each meter must be provided with its own unique address. The meter address (Slave ID) may be programmed between 1 and 247. The transmit delay may be set between 0 and 199 ms. The parity can be set to even, odd, or none with 1 or 2 stop bits.

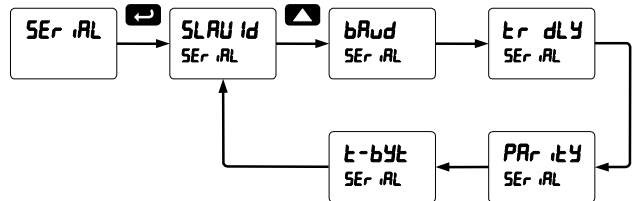

Changes made to the Serial menu are initialized after the MENU key is pressed or after navigating through the t-byte parameter.

Select Menu (SELEct)

The *Select* menu is used to select the signal input conditioning function applied to the inputs (linear, square root, or programmable exponent), math function for A & B, constants, low-flow cutoff, total count direction (up or down from a preset amount), and analog output programming. Multi-point linearization is part of the linear function selection.

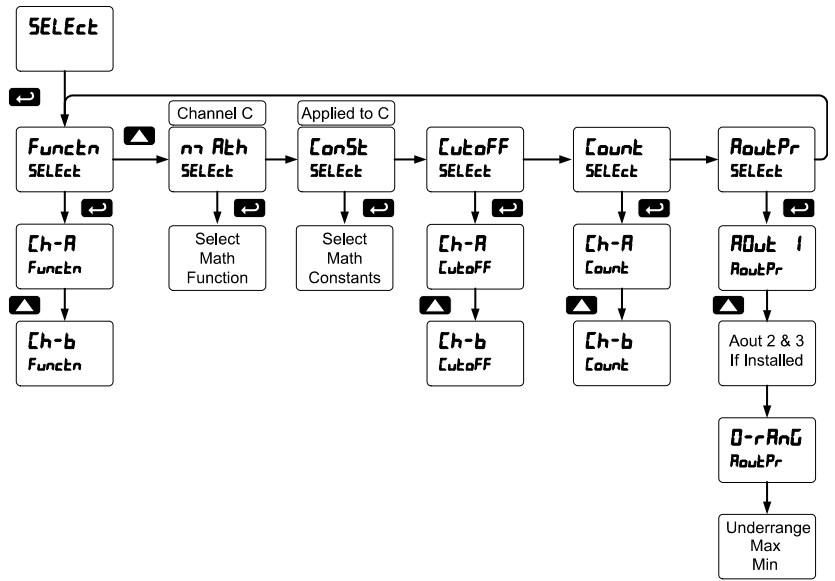

Signal Input Conditioning (Function)

The *Function* menu is used to select the input-to-output transfer function applied to the input signal: linear, square root, or programmable exponent. Multi-point linearization is part of the linear function selection. Each input channel signal input conditioning function is programmed independently.

Meters are set up at the factory for linear function with 2-point linearization. The linear function provides a display that is linear with respect to the input signal.

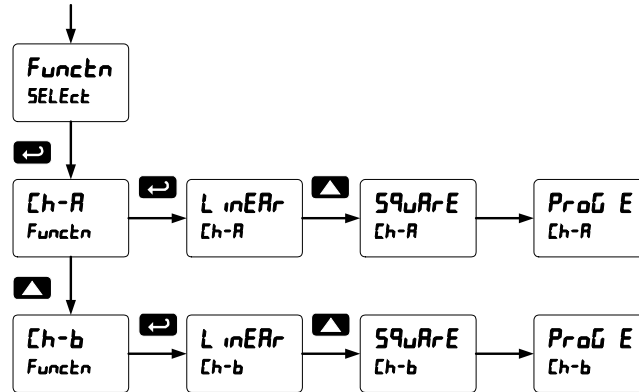

Square Root Linearization (SqURrE)

The square root function is used to calculate flow measured with a differential pressure transmitter. The flow rate is proportional to the square root of the differential pressure. Scale the meter so that the low input signal (e.g. 4 mA) is equal to zero flow and the high input signal (e.g. 20 mA) is equal to the maximum flow.

Programmable Exponent Linearization (ProG E)

The programmable exponent function is used to calculate open-channel flow measured with a level transmitter in weirs and flumes. The flow rate is proportional to the head height. Scale the meter so that the low input signal (e.g. 4 mA) is equal to zero flow and the high input signal (e.g. 20 mA) is equal to the maximum flow. This method works well for all weirs and flumes that have a simple exponent in the flow calculation formula. For weirs and flumes with complex exponents it is necessary to use a strapping table and the 32-point linearization of the meter.

Multi-Point Linearization (L inERr)

Meters are set up at the factory for linear function with 2-point linearization. Up to 32 linearization points can be selected for each channel under the linear function. The multi-point linearization can be used to linearize the display for non-linear signals such as those from level transmitters used to measure volume in odd-shaped tanks or to convert level to flow using weirs and flumes with complex exponent.

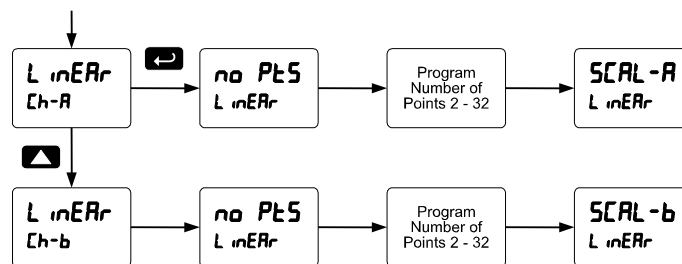

Note: After Scale is displayed continue pressing the Enter button until the meter completes the scaling of the input and display values.

Math Function (מחשבים)

The *Math* menu is used to select the math function that will determine the channel C value. These math functions are a combination of input channels A and B, and will display when channel C is selected in the *Display* menu.

A and B refer to the rate of channel A and B. tA and tB refer to the totals of channel A and B. GtA and GtB refer to the grand totals of channel A and B. The following math functions are available.

Function	Display	Description
סכום	Sum	$C = (A+B+P)*F$
הפרש	Difference	$C = (A-B+P)*F$
הפרש מוחלט	Absolute difference	$C = ((\text{Absolute value of } (A-B))+P)*F$
מוצע	Average	$C = (((A+B)/2)+P)*F$
כפל	Multiplication	$C = ((A*B)+P)*F$
חילוק	Divide	$C = ((A/B)+P)*F$
הגדול מ-A או B	Max of A or B	$C = ((\text{High value of channel A or B})+P)*F$
הקטן מ-A או B	Min of A or B	$C = ((\text{Low value of channel A or B})+P)*F$
הוצאה	Draw	$C = ((A/B)-1)*F$
מוצע משוקלל	Weighted avg.	$C = ((B-A)*F)+A$
יחס	Ratio	$C = (A/B)*F$
יחס 2	Ratio 2	$C = ((B-A)/A)+P*F$
ריכוז	Concentration	$C = (A/(A+B))*F$
סכום כולל	Sum total	$C = (tA+tB+P)*F$
סכום כולל גדול	Sum grand total	$C = (GtA+GtB+P)*F$
הפרש כולל	Difference of total	$C = (tA-tB+P)*F$
הפרש כולל גדול	Diff. of grand total	$C = (GtA-GtB+P)*F$
יחס כולל	Total ratio	$C = (tA/tB)*F$
יחס כולל 2	Total ratio 2	$C = ((tB-tA)/tA)*F$
אחוז כולל	Total percent	$C = (tA/(tA+tB))*100$

Math Constants (מקומות)

The *Math Constants* menu is used to set the constants used in channel C math. The math functions include adder constant P, and factor constant F.

The *Adder* constant (P) may be set from -99.999 to 999.999.

The *Factor* constant (F) may be set from 0.001 to 999.999.

The chart on page 48 details the math functions that may be selected in the *Math Function* menu.

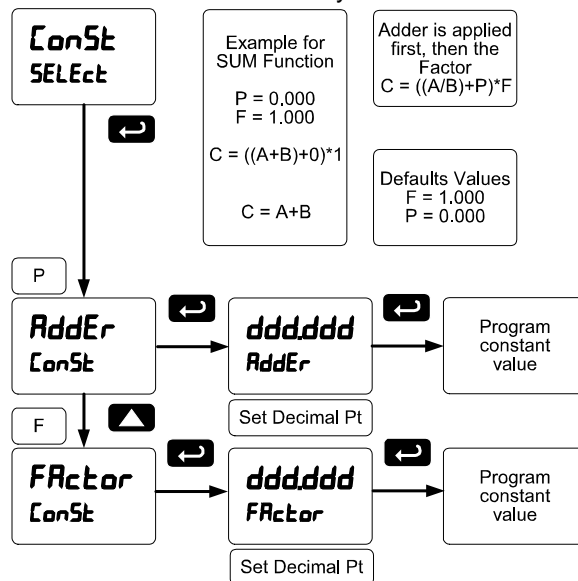

Low-Flow Cutoff (Cutoff)

The low-flow cutoff feature allows the meter to be programmed so that the often-unsteady output from a differential pressure transmitter, at low flow rates, always displays zero on the meter. The low-flow cutoff for each channel is programmed independently.

The cutoff value may be programmed from 0 to 999999. The meter will display zero below the cutoff value. Programming the cutoff value to zero disables the cutoff feature.

Totalizer Count Up/Down (Count)

The totalizer count up/down menu may be used to program the total and grand total to either count up from 0 when reset or count down from a programmed value when reset. Total and grand total may have their countdown numbers programmed individually from 0 to 999999.

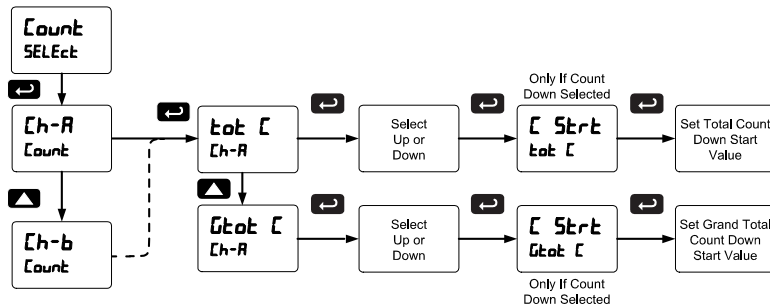

Analog Output Programming (AoutPr)

The *Analog Output Programming* menu is used to program the behavior of the 4-20 mA output. The following parameters and functions are programmed in this menu:

1. Source: Source for generating the 4-20 mA output
2. Overrange: Analog output value with display in overrange condition
3. Underrange: Analog output value with display in underrange condition
4. Break: Analog output value when loop break is detected
5. Max: Maximum analog output value allowed regardless of input
6. Min: Minimum analog output value allowed regardless of input

Analog Output Source

The analog output source can be based on either of the input channel rate, total, or grand totals (Ch-A, Ch-B), the math channel (Ch-C), maximum stored value of either input channel (Hi-A, Hi-B), minimum stored value of either input channel (Lo-A, Lo-B), relay set points, or the Modbus input.

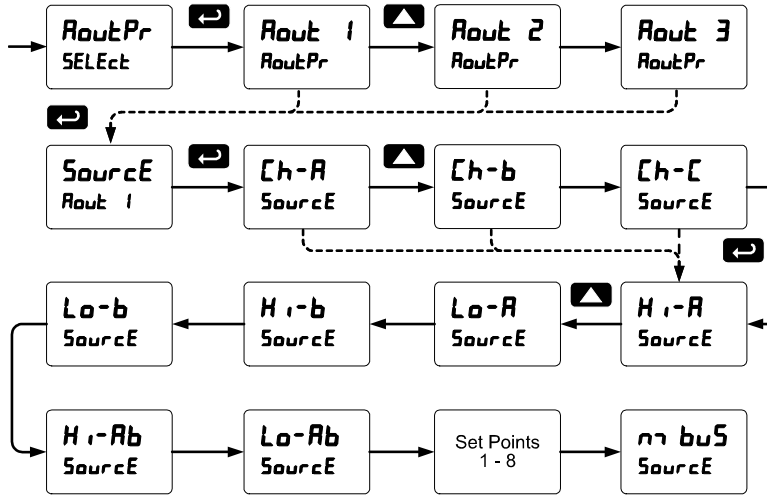

To base an analog output on the rate, total, or grand total of channels A or B, select the channel in the *Analog Output Source* menu. Then select the rate, total, or grand total as the source reference for the output, and program the output scale.

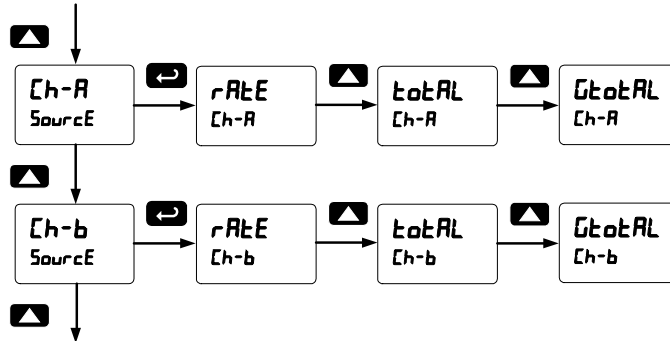

Programmable Function Keys User Menu (uSEr)

The *User* menu allows the user to assign the front panel function keys F1, F2, and F3, the digital input F4 (a digital input located on the signal input connector), and up to eight additional digital inputs to access most of the menus or to activate certain functions immediately (e.g. reset max & min, hold relay states, etc.). This allows the meter to be greatly customized for use in specialized applications.

Up to eight digital outputs can be assigned to a number of actions and functions executed by the meter (i.e. alarms, relay acknowledgement, reset max, min, or max & min, tare, and reset tare). The digital outputs can be used to trigger external alarms or lights to indicate these specific events.

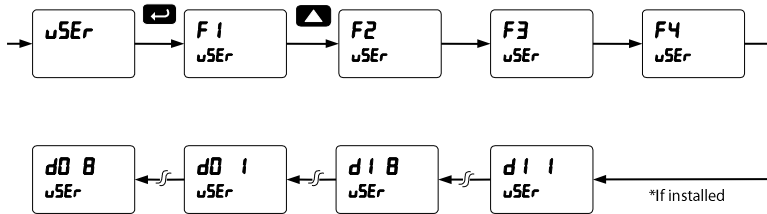

Function Keys & Digital I/O Available Settings

Refer to the following table for descriptions of each available function key or digital I/O setting.

Display	Description	Display	Description
rSt Hi	Reset the stored maximum display values for all channels	Ln2 Hi	Display maximum channel B display value on line 2
rSt Lo	Reset the stored minimum display values for all channels	Ln2 Lo	Display minimum Channel B display value on line 2
rSt HL	Reset the stored maximum & minimum display values for all channels	Ln2 HL	Display maximum & minimum channel B display values on line 2
rELAY	Directly access the relay menu	Ln2 Hc	Display minimum channel C display value on line 2
SEt I*	Directly access the set point menu for relay 1 (*through 8)	Ln2 Hc	Display maximum & minimum channel C display values on line 2
rLY d	Disable all relays until a button assigned to <i>enable relays (rLY E)</i> is pressed	L tHLc	Display maximum channel C display value on line 2
rLY E	Enable all relays to function as they have been programmed	F On I*	Force relay 1 (*through 4) into the on state. This function is used in conjunction with a digital input expansion module to achieve interlock functionality. See page 40 for details about interlock relays.
0 Hold	Hold current relay states and analog output as they are until a button assigned to <i>enable relays (rLY E)</i> is pressed	Control	Directly access the control menu
d Hold	Hold the current display value, relay states, and analog output momentarily while the function key or digital input is active. The process value will continue to be calculated in the background.	d SABL	Disable the selected function key or digital I/O
d Abc	Scrolls values for A, B & C when activated. Keeps the last value for 10 seconds and then it returns to its assignment. Values are displayed on display line 1 and the corresponding channel and units on display line 2.	RcH	Acknowledge all active relays that are in a manual operation mode such as auto-manual or latching
d tot	Scrolls through totals for channels A, B, and C (which is the sum of A and B). Values are displayed on display line 1.	rESEt	Directly access the reset menu
d Gtot	Scrolls through grand totals for channels A, B, and C (which is the sum of A and B). Values are displayed on display line 1.	rSt t	Reset totals for all channels
Ln1 Hi	Display maximum channel A display value on line 1	rSt Gt	Reset grand totals for all channels
Ln1 Lo	Display minimum channel A display value on line 1	rSt tA	Reset total for channel A
Ln1 HL	Display maximum & minimum channel A display values on line 1	rSt GtA	Reset grand total for channel A
		rSt tB	Reset total for channel B
		rSt GtB	Reset grand total for channel B
		rnEsu	Mimic the menu button functionality (digital inputs only)
		r rHLt	Mimic the right arrow/F1 button functionality (digital inputs only)
		uP	Mimic the up arrow/F2 button functionality (digital inputs only)
		EntEr	Mimic the enter/F3 button functionality (digital inputs only)
		ALn r I*	Provide indication when alarm 1 (*through 8) has been triggered (digital outputs only)

Internal Calibration (ICAL)

The meter is factory calibrated prior to shipment to read in milliamps and volts depending on the input selection. The calibration equipment is certified to NIST standards.

The use of calibrated signal sources is necessary to perform the internal calibration of the meter.

Check calibration of the meter at least every 12 months. Each input and input type must be recalibrated separately.

Notes:

1. If meter is in operation and it is intended to accept only one input type (e.g. 4-20 mA), recalibration of other input is not necessary.
2. Allow the meter to warm up for at least 15 minutes before performing the internal calibration procedure.

The *Internal calibration* menu is part of the *Advanced Features* menu.

1. Press and hold the Menu button for three seconds to access the advanced features of the meter.
2. Press the Up arrow button to scroll to the *Internal calibration* menu (ICAL) and press Enter.
3. Select channel A (Ch-A) or channel B (Ch-b) and press enter.
4. The meter displays either current calibration (C CAL) or voltage calibration (U CAL), according to the input setup. Press Enter to start the calibration process.

Example of Internal Calibration for current input:

5. The meter displays *low* input current message (C Lo). Apply the low input signal and press Enter. The display flashes for a moment while the meter is accepting the low input signal.
6. After the display stops flashing, a number is displayed with the leftmost digit brighter than the rest. The bright digit is the active digit that can be changed by pressing the Up arrow button. Press the Right arrow button to move to the next digit.
7. Set the display value to correspond to the input signal being calibrated, typically 4.000 mA.
8. The display moves to the *high* input calibration (C Hi). Apply the high input signal and press Enter.
9. Set the display for the high input calibration, in the same way as it was set for the low input calibration, typically 20.000 mA.

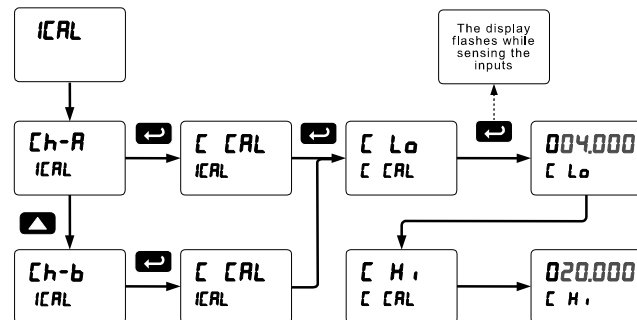

The graphic above shows the calibration of the current input. The voltage input is calibrated in a similar way.

Tips:

- Low and high input signals can be any valid values within the range of the meter.
- Observe minimum input span requirements between input 1 and input 2.
- Low input should be less than high input signal.

Error Message (Error)

An error message indicates that the calibration or scaling process was not successful.

After the error message is displayed, the meter reverts to input 2 during calibration or scaling and to input 1 during internal calibration, allowing the appropriate input signal to be applied or programmed.

The error message might be caused by any of the following conditions:

1. Input signal is not connected to the proper terminals, or it is connected backwards.
2. Wrong signal selection in *Setup* menu.
3. Minimum input span requirements not maintained (see page 27).

Meter Operation





The meter is capable of accepting two input channels (A and B) of either current (0-20 mA, 4-20 mA) or voltage signals (0-5 V, 1-5 V, 0-10 V, ± 10 V) and displaying these signals in engineering units from -99999 to 999999 (e.g. a 4-20 mA signal could be displayed as -50.000 to 50.000). A totalizer can be programmed to count the scaled engineering units, interpreting it as count per second, minute, hour, or day. The scaled rate and total for each channel can be displayed on the top or bottom displays.

A math function channel (C) is available to perform operations on channel A and B rates or totals, with adder and factor constants, and display the results. Engineering units or tags may be displayed with these three channels.

The dual-line display can be customized by the user. Typically, display line 1 is used to display the math channel C, while line 2 is used to alternate between displaying input channels A and B rate or total.

Additionally, the meter can be set up to display any input or math channel on line 1 and a unit or tag on line 2. The relays and analog output can be programmed to operate based on any input or math channel.

Front Panel Buttons Operation

Button Symbol	Description
	Press to enter or exit Programming Mode, view settings, or exit max/min readings
	Press to reset max/min readings or other parameter/function assigned through the <i>User</i> menu
	Press to display max/min readings for channel A or other parameter/function assigned through the <i>User</i> menu
	Press to acknowledge relays or other parameters/function assigned through the <i>User</i> menu

Function Keys Operation

During operation, the programmable function keys operate according to the way they have been programmed in the *Advanced Features – User* menu.

The table above shows the factory default settings for F1, F2, and F3.

F4 Operation

A digital input, F4, is standard on the meter. This digital input is programmed identically to function keys F1, F2, and F3. The input is triggered with a contact closure to COM, or with an active low signal. During operation, F4 operates according to the way it has been programmed in the *Advanced Features – User* menu.

Maximum/Minimum Readings

The max & min readings (peak & valley) reached by the process can be displayed either continuously or momentary:

1. Display briefly by assigning to the F1-F3 function keys or to the digital inputs in the *User* menu.
2. Display continuously by assigning either display to max/min through the *Display* menu.

Any of the F1-F3 function keys (buttons) and the digital inputs can be programmed to reset the max & min readings. The meters are set at the factory to display the max/min reading by pressing the Up arrow/F2 button and to use the Right arrow/F1 button to reset the max/min.

To display max and min channel A reading using function key with factory defaults:

1. Press Up arrow/F2 button to display minimum reading of channel A since the last reset/power-up. The display will then display the maximum reading of channel A since the last reset/power-up.
2. To reset max/min press Right arrow/F1 button. The max & min displays are reset to actual values.
3. Press Menu to exit max/min display reading.

Troubleshooting

The rugged design and the user-friendly interface of the meter should make it unusual for the installer or operator to refer to this section of the manual. However, due to the many features and functions of the meter, it's possible that the setup of the meter does not agree with what an operator expects to see.

If the meter is not working as expected, refer to the *Diagnostics* menu and recommendations below.

Diagnostics Menu (d ,RG)

The *Diagnostics* menu is located in the *Advanced Features* menu. To access the *Diagnostics* menu, see *Advanced Features Menu*, page 43.

This menu allows the user to test the functionality of all the meter LEDs, check the meter's software and version information, and erase the MeterView Pro software installation files from the meter. Press the Enter button to view the settings and the Menu button to exit at any time.

For a description of the diagnostic messages, see *Advanced Features Menu & Display Messages*, page 43.

Determining Software Version

To determine the software version of a meter:

1. Go to the *Diagnostics* menu (d ,RG) and press Enter button.
2. Press Up arrow button and scroll to Information menu (inF0).
3. Press Enter to access the software number (5Ft) and version (UEr) information. Write down the information as it is displayed. Continue pressing Enter until all the information is displayed.
4. The meter returns to Run Mode after displaying all the settings.

Reset Meter to Factory Defaults

When the parameters have been changed in a way that is difficult to determine what's happening, it might be better to start the setup process from the factory defaults.

Instructions to load factory defaults:

1. Enter the *Advanced Features* menu. See *Advanced Features Menu*, page 43.
2. Press Up arrow to go to *Diagnostics* menu
3. Press and hold Right arrow for three seconds, press Enter when display flashes rESEt.
Note: If Enter is not pressed within three seconds, the display returns to Run Mode.
4. The meter goes through an initialization sequence (similar as on power-up), and loads the factory default settings.

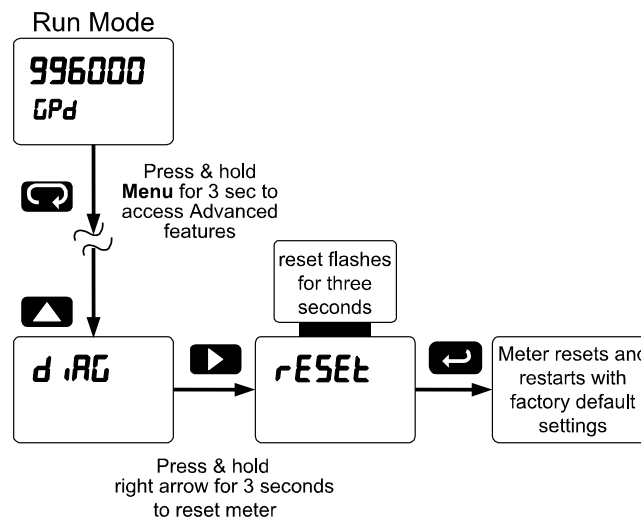

Factory Defaults & User Settings

The following table shows the factory setting for most of the programmable parameters on the meter.

Parameter	Display	Default Setting
Input type	<i>inP u t</i>	
Input type, channel A	<i>Ch-A</i>	4-20 mA
Input type, channel B	<i>Ch-b</i>	4-20 mA
Total, channel A	<i>Ch-A</i>	Yes
Total, channel B	<i>Ch-b</i>	Yes
Units	<i>u n i t s</i>	
Rate unit, channel A	<i>Ch-A</i>	mA-A
Rate unit, channel B	<i>Ch-b</i>	mA-b
Unit, channel C	<i>Ch-C</i>	mA-C
Total unit, channel A	<i>tot-A</i>	tot-A
Grand total unit, ch-A	<i>Gtot-A</i>	Gtot-A
Total unit, channel B	<i>tot-b</i>	tot-b
Grand total unit, ch-B	<i>Gtot-b</i>	Gtot-B
Decimal Point	<i>dEc Pt</i>	
Rate, channel A	<i>rAtE</i>	3
Total, channel A	<i>totAL</i>	1
Grand total, channel A	<i>GtotAL</i>	0
Rate, channel B	<i>rAtE</i>	3
Total, channel B	<i>totAL</i>	1
Grand total, channel B	<i>GtotAL</i>	0
Channel C	<i>Ch-C</i>	3
Number of points	<i>no PtS</i>	
Number of points, ch A	<i>Ch-A</i>	2
Number of points, ch B	<i>Ch-b</i>	2
Scaling, (channel A)	<i>ScAL A</i>	
Input 1, channel A	<i>inP 1</i>	4.000 mA
Display 1, channel A	<i>d 1S 1</i>	4.000
Input 2, channel A	<i>inP 2</i>	20.000 mA
Display 2, channel A	<i>d 1S 2</i>	20.000
Scaling (channel B)	<i>ScAL b</i>	
Input 1, channel B	<i>inP 1</i>	4.000 mA
Display 1, channel B	<i>d 1S 1</i>	4.000

Parameter	Display	Default Setting
Input 2, channel B	<i>inP 2</i>	20.000 mA
Display 2, channel B	<i>d 1S 2</i>	20.000
Total setup	<i>tSEt u P</i>	
Time base, channel A	<i>t bASE</i>	Sec
Total conversion factor, Ch-A	<i>t CF</i>	1.000
Grand total conversion factor, Ch-A	<i>Gt CF</i>	1.000
Time base, channel B	<i>t bASE</i>	Sec
Total conversion factor, Ch-B	<i>t CF</i>	1.000
Grand total conversion factor, Ch-B	<i>Gt CF</i>	1.000
Total reset	<i>t rESEt</i>	
Total reset, channel A	<i>t rSt</i>	Manual
Grand total reset, Ch-A	<i>Gt rSt</i>	Manual
Total reset, channel B	<i>t rSt</i>	Manual
Grand total reset, Ch-B	<i>Gt rSt</i>	Manual
Display assignment	<i>dSPLRy</i>	
Display line 1	<i>d Ch-A</i>	Channel A
Display line 2	<i>d Ch-b</i>	Channel B
Display intensity	<i>d- iNtY</i>	8
Relay	<i>rELAY</i>	
Relay 1 assignment	<i>Ch-A</i>	Channel A total
Relay 1 action	<i>Act 1</i>	Automatic
Relay 1 set point	<i>SEt 1</i>	100.0
Relay 2 assignment	<i>Ch-A</i>	Channel A total
Relay 2 action	<i>Act 2</i>	Automatic
Relay 2 set point	<i>SEt 2</i>	200.0
Relay 3 assignment	<i>Ch-A</i>	Channel A rate
Relay 3 action	<i>Act 3</i>	Automatic
Relay 3 set point	<i>SEt 3</i>	3.000
Relay 3 reset point	<i>rSt 3</i>	2.500
Relay 4 assignment	<i>Ch-A</i>	Channel A rate

Parameter	Display	Default Setting
Relay 4 action	Rct 4	Automatic
Relay 4 set point	SEt 4	4.000
Relay 4 reset point	rSEt 4	3.500
Fail-safe relay 1 to 4	FLS i	Off
On delay relay 1 to 4	On i	0.0 sec
Off delay relay 1 to 4	OFF i	0.0 sec
Loop break relay 1 to 4	IgnorE	Ignore
Analog output	Route	
Display 1 analog out	d i5 i	4.000
Output 1 value	Out i	4.000 mA
Display 2 analog out	d i5 2	20.000
Output 2 value	Out 2	20.000 mA
Source analog output	Source	Channel A
Overrange output	U-rRnG	21.000 mA
Underrange output	u-rRnG	3.000 mA
Loop break output	brERRH	3.000 mA
Maximum output	rr RH	23.000 mA
Minimum output	rr rn	3.000 mA
Filter	FiLtEr	
Filter, channel A	Ch-A	70
Filter, channel B	Ch-b	70
Bypass, channel A	bYPASS	0.2
Bypass, channel B	bYPASS	0.2
Round	round	1
Cutoff	CutOFF	
Cutoff value, channel A	Ch-A	0.000 (disabled)
Cutoff value, channel B	Ch-b	0.000 (disabled)
Serial	SEr iRL	
Slave ID (Address)	SLAVId	247

Parameter	Display	Default Setting
Baud rate	bAud	9600
Transmit delay	tr dLY	50 ms
Parity	PARiTY	Even
Byte-to-byte timeout	t-byt	010 (0.1 sec)
Math	rr Rth	
Math, channel C	Sumr	Sum
Adder (constant P)	AddEr	0.000
Factor (constant F)	FRctOr	1.000
User	uSEr	
F1 function key	F1	Reset max & min
F2 function key	F2	Line 1 Max & Min
F3 function key	F3	Acknowledge relays
F4 function (digital input)	F4	Acknowledge relays
Digital input 1	d i 1	Menu
Digital input 2	d i 2	Right arrow
Digital input 3	d i 3	Up arrow
Digital input 4	d i 4	Enter
Digital output 1	dO 1	Alarm 1
Digital output 2	dO 2	Alarm 2
Digital output 3	dO 3	Alarm 3
Digital output 4	dO 4	Alarm 4
Password	PASS	
Password 1	PASS 1	000000 (unlocked)
Password 2	PASS 2	000000 (unlocked)
Password 3	PASS 3	000000 (unlocked)
Total	totRL	000000 (unlocked)
Grand total	GrTotRL	000000 (unlocked)

Troubleshooting Tips

Symptom	Check/Action
No display at all	Check power at power connector
Not able to change setup or programming, <i>Lcd</i> is displayed	Meter is password-protected, enter correct six-digit password to unlock
Meter displays error message during calibration (<i>Error</i>)	Check: 1. Signal connections 2. Input selected in <i>Setup</i> menu 3. Minimum input span requirements
Meter displays 1. <i>999999</i> 2. <i>-99999</i>	Check: 1. Input selected in <i>Setup</i> menu 2. Corresponding signal at Signal connector
Display is unstable	Check: 1. Input signal stability and value 2. Display scaling vs. input signal 3. Filter and bypass values (increase)
Display response is too slow	Check filter and bypass values
Display reading is not accurate	Check: 1. Signal input conditioner selected: Linear, square root, etc. 2. Scaling or calibration
Display does not respond to input changes, reading a fixed number	Check: 1. Display assignment, it might be displaying max, min, or set point.
Display alternates between 1. <i>H</i> and a number 2. <i>L</i> and a number	Press Menu to exit max/min display readings.
Relay operation is reversed	Check: 1. Fail-safe in <i>Setup</i> menu 2. Wiring of relay contacts
Relay and status LED do not respond to signal	Check: 1. Relay action in <i>Setup</i> menu 2. Set and reset points
Flashing relay status LEDs	Relays in manual control mode or relay interlock switches opened.
Meter not communicating with application programs	Check: 1. Serial adapter and cable 2. Serial settings 3. Meter address and baud rate
If the display locks up or the meter does not respond at all	Cycle the power to reboot the microprocessor.
Other symptoms not described above	Call Technical Support for assistance.

This Page Intentionally Left Blank



EU Declaration of Conformity

Issued in accordance with ISO/IEC 17050-1:2004.

We,

Precision Digital Corporation
233 South Street
Hopkinton, MA 01748 USA

as the manufacturer, declare under our sole responsibility that the product(s),

Model PD6262 ProVu Series Dual-Input Analog Rate/Totalizer

to which this declaration relates, is in conformity with the European Union Directives shown below:

2014/35/EU	Low Voltage Directive
2014/30/EU	EMC Directive
2011/65/EU	RoHS Directive

This conformity is based on compliance with the application of harmonized or applicable technical standards and, when applicable or required, a European Union notified body certification.

Standards:

EN 55022:2003
EN 61000-6-2:2001
EN 61010-1:2001
EN 61326:2006

The standards EN 55022:2003, EN 61000-6-2:2001, EN 61010-1:2001, and EN 61326:2006 are no longer harmonized. The requirements of these standards have been checked against the harmonized standards EN 55022:2010, EN 61000-6-2:2005, EN 61010-1:2010, and EN 61326:2013 and there were no major technical changes affecting the latest technical knowledge for the products listed above.

Product Markings:



Signed for and on behalf of Precision Digital Corporation:



Name: Jeffrey Peters
Company: Precision Digital Corporation
Title: President
Date: 04/20/2016

Document No: DoC PD6262 {042016}

How to Contact Precision Digital

- For Technical Support, please
Call: (800) 610-5239 or (508) 655-7300
Fax: (508) 655-8990
Email: support@predig.com
- For Sales Support or to place an order, please contact your local distributor or
Call: (800) 343-1001 or (508) 655-7300
Fax: (508) 655-8990
Email: sales@predig.com
- For the latest version of this manual, please visit
www.predig.com

Order from:

C A Briggs Company

622 Mary Street; Suite 101

Warminster, PA 18974

Phone: 267-673-8117 - Fax: 267-673-8118

Sales@cabriggs.com - www.cabriggs.com

PRECISION DIGITAL CORPORATION

233 South Street • Hopkinton MA 01748 USA

Tel (800) 343-1001 • Fax (508) 655-8990



www.predig.com