

PD8-765

ProtEX-MAX™ Process & Temperature Meter

ProtEX™
MAX



IECEX



PROCESS & TEMP

- 4-20 mA, ± 10 V, TC & RTD Inputs
- Large 1.2" (31 mm) 4-Digit Display
- Explosion-Proof, IP68, NEMA 4X Enclosure
- Modern, Sleek and Practical Enclosure
- Display Mountable at 0°, 90°, 180°, & 270° Degrees
- Operating Temperature Range of -40°C to 65°C
- SafeTouch® Through-Glass Button Programming
- Free MeterView® Software - Configuration & Data Acquisition
- Sunlight Readable Display
- Universal Power Supply 85-265 VAC
- 12-36 VDC/12-24 VAC Power Option
- Isolated 24 VDC @ 25 mA Transmitter Power Supply
- 2 Relays + 4-20 mA Output Option
- Pump Alternation Capability
- USB, RS-232, & RS-485 Serial Communication Options
- Free Modbus® RTU with Serial Adapter Option
- Copy Meter Settings to Other Meters
- Max/Min Display

PRECISION DIGITAL CORPORATION

**PRECISION
DIGITAL**

www.CABriggs.com

PD8-765 ProtEX-MAX™ Process & Temperature Meter



Through-Glass
Button Programming



Sunlight Readable
Display



FEATURE RICH & SIMPLE TO USE

The PD8-765 ProtEX-MAX is an explosion-proof version of the popular Trident X2 process and temperature meter. It can satisfy a wide variety of process applications. The ProtEX-MAX can be field programmed to accept process voltage (0-5V, 1-5V, etc) and current (4-20 mA) inputs, 100 Ohm RTDs, and the four most common thermocouples. It is housed in an IP68 NEMA 4X rated explosion-proof die cast aluminum enclosure and is a fully approved product carrying FM, CSA, ATEX, and IECEx approvals. There are two power options for the ProtEX-MAX: 85 to 265 VAC or 12-36 VDC and it can provide 24 VDC to power the transmitter if needed. Programming and setup can be performed with the four the four SafeTouch® through-glass buttons, free MeterView software, or using the Copy function.

HUGE 1.2" 4-DIGIT DISPLAY

The PD8-765 ProtEX-MAX display height is an astounding 1.2" (30.5 mm). It can be read easily from distances of up to 30 feet away! The display intensity function allows the selection of eight levels of intensity for various lighting conditions, including direct sunlight.

VERSATILE OPERATION

Look to the PD8-765 ProtEX-MAX meter for the key features and options you want and don't worry about getting bogged down in a confusing array of things you don't need. The Trident's Max/Min function, 2 relays + 4-20 mA output, serial communication, and Modbus RTU options provide all the utility you need to handle all the common applications.

Maximum/Minimum

To display the maximum and minimum readings since the last reset/power-up, use the Up arrow/Max button.

Powerful Relay Functionality

All relay functions are set up from the front panel or from a PC running MeterView® software.

- Automatic reset only
- Automatic or manual reset
- Latching or non-latching relays
- Pump alternation control
- On and off time delays from 0 to 199 seconds
- Fail-safe operation is user selectable

Isolated 4-20 mA Transmitter Output

The PD8-765's Isolated 4-20 mA output option converts the meter into a transmitter with a digital display; perfect for temperature applications!

Modbus RTU

Use the PD8-765 ProtEX-MAX's Modbus RTU communications to connect the Trident to a PLC, SCADA system or other digital device. It is a standard feature on all Trident models.

PD8-765 ProtEX-MAX™ Process & Temperature Meter

Pump Alternation

The PD8-765, in pump alternation mode, will automatically alternate two pumps:

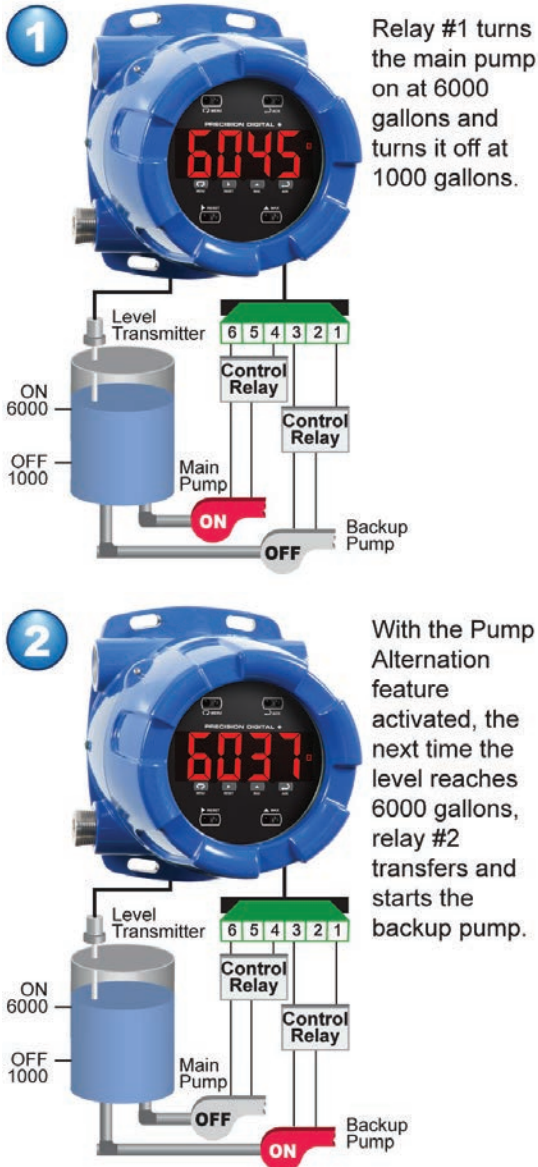

EASY SETUP AND PROGRAMMING

The PD8-765 ProtEX-MAX is easily setup and programmed using the simple four-button programming method. The meter can also be programmed using a PC and Precision Digital's free MeterView software or "cloned" with the Copy function. There is only one switch on the entire meter, no jumpers, and no need to ever open the case.

SafeTouch® Button Programming

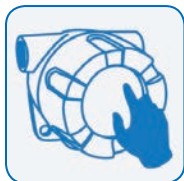

The ProtEX-MAX PD8-765 is equipped with four sensors that operate as through-glass buttons so that it can be programmed and operated without removing the cover (and exposing the electronics) in a hazardous area. The SafeTouch buttons are configured by default to duplicate the function of the front panel mechanical pushbuttons associated with the integrated meter.

Meter Copy

The Copy function is used to copy (or clone) all the settings from one PD8-765 meter to other PD8-765 meters in less than 10 seconds. The Copy feature does not require a serial communication adapter, it only requires the optional cable assembly (PDA7420).



Programming From a PC with MeterView®

Precision Digital's free MeterView® software allows all PD8-765 setup parameters to be programmed from a PC and to save the configuration settings to a file for reporting or programming other meters. And since the serial adapter is an external device, one serial adapter can program an infinite number of meters!

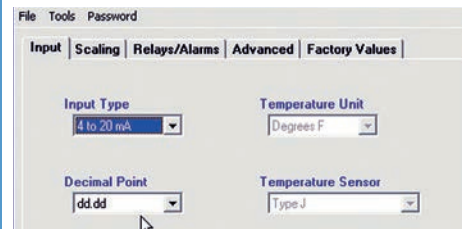

Configure Input

- Input type
- Decimal point
- Temp units
- Sensor type

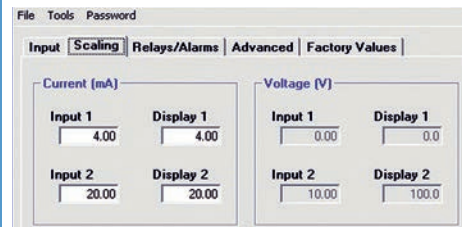

Meter Scaling

- Scale input
- No cryptic codes
- Simple to use

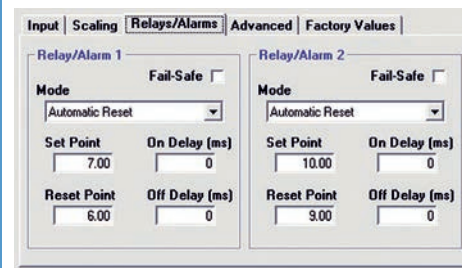

Set Relays/Alarms

- Select mode
- Set/reset points
- Fail-safe operation
- On & off delays

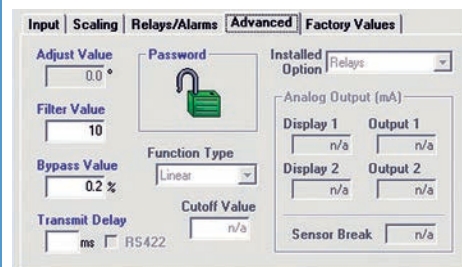

Advanced Settings

- Password
- Filter & bypass
- Transmit delay
- Function type
- Cutoff value

PD8-765 ProtEX-MAX™ Process & Temperature Meter

Learn How to Program the PD8-765 with the Trident Virtual Meter on PC or Mobile Device



PD8-765 operators can take advantage of the Trident Virtual Meter. This is a great tool for getting comfortable with programming 4-20 mA, 0-10 V, Thermocouple and RTD inputs. You can also practice scaling the meter without a signal, calibrating the meter, setting up relays, and more. The Trident Virtual Meter is available on your desktop or mobile device. Just visit TridentVirtualMeter.com to start practice programming your PD8-765 meter.

DATA ACQUISITION

Digital panel meters make a great front end to a PC-based data acquisition system. They are easy to set up, can be used for a wide range of inputs, will power the transmitter, and best of all provide a local display of the process. Precision Digital has the perfect package with its Trident Digital Panel Meters, a wide selection of serial adapters and converters and free MeterView software. Data is displayed on the PC and written to a file that could then be imported into a spreadsheet or other application.

Data Logging up to 100 Trident Meters

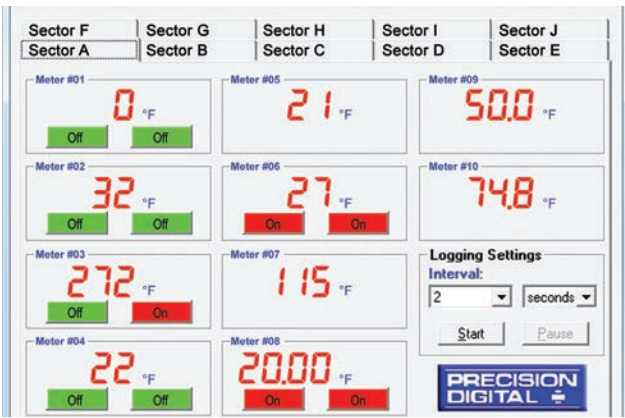

Sample File Generated by MeterView®

PD8-765 Log File						
Name: C:\MV3\logfile.htm			Created: 1/7/2011 5:34:12 PM			
Serial Port:	Connection speed:	Logging rate:				
COM 1	2400 Baud	1 update every 10 seconds				
Date & Time	Tag Number	Address	Display	Units	Relay 1	Relay 2
1/7/2011 5:34:12 PM	Tank 1 Level	06	17.70	Feet	P1 On	P2 Off
1/7/2011 5:34:12 PM	Tank 2 Level	07	18.18	Feet	P3 Off	P4 Off
1/7/2011 5:34:12 PM	Tank 3 Level	08	20.54	Feet	P5 On	P6 Off
1/7/2011 5:34:12 PM	Tank 1 Temp	09	74	°F	Off	Off
1/7/2011 5:34:12 PM	Tank 2 Temp	10	72	°F	Off	Off
1/7/2011 5:34:12 PM	Tank 3 Temp	11	72	°F	Off	Off
1/7/2011 5:34:22 PM	Tank 1 Level	06	17.58	Feet	P1 On	P2 Off
1/7/2011 5:34:22 PM	Tank 2 Level	07	18.04	Feet	P3 Off	P4 Off
1/7/2011 5:34:22 PM	Tank 3 Level	08	19.79	Feet	P5 Off	P6 Off
1/7/2011 5:34:22 PM	Tank 1 Temp	09	74	°F	Off	Off
1/7/2011 5:34:22 PM	Tank 2 Temp	10	72	°F	Off	Off

PROCESS & TEMPERATURE INPUTS

The PD8-765 is factory calibrated to accept 4-20 mA, ±10 VDC, type J, K, T, or E thermocouples and 100 Ω platinum RTDs. Process inputs can be scaled with or without applying an input for virtually any engineering units. Temperature inputs can be programmed to display in degrees Fahrenheit or Celsius and the type K thermocouple can display up to 2300 °F.

Current & Voltage Inputs

Setting up the meter to accept a current or voltage input could not be easier. All setup is performed with the front panel buttons and there are no switches or jumpers to deal with.

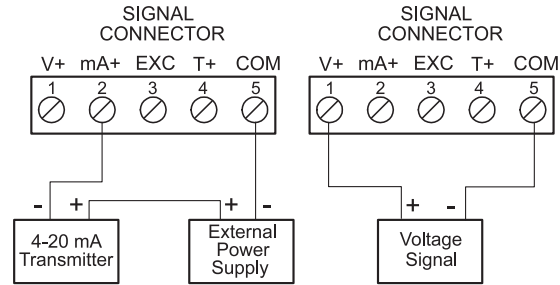

Transmitter Powered by External Supply

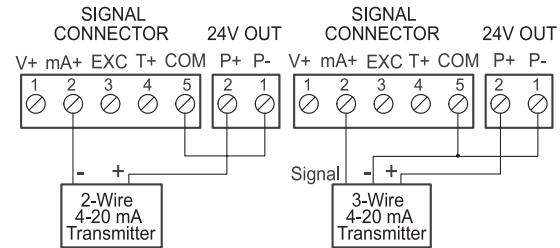

Transmitter Powered by Internal Supply (optional)

Current Overload Protection

To protect the instrument from unexpected current overload, the current input circuit contains a resettable fuse. The fuse limits the current to a safe level when it detects a fault condition, and automatically resets itself when the fault condition is removed.

Thermocouple & RTD inputs

Setting up the Trident to accept a thermocouple or RTD input is simply a matter of setting a switch at the rear of the case and selecting the input type from the menu.

The meter accepts J, K, T, or E type thermocouples as well as two, three, or four-wire 100 Ω platinum RTDs.

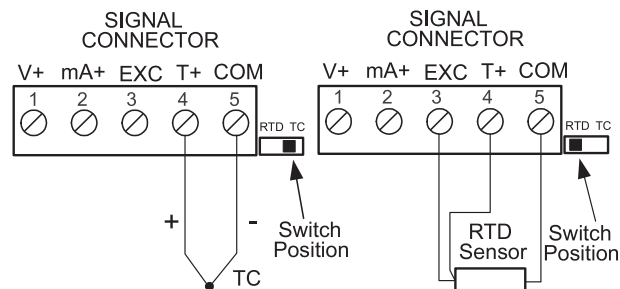

SPECIFICATIONS

Except where noted all specifications apply to operation at +25°C.

General

Display: 1.20" (30.5 mm) red LED, 4 digits (-1999 to 9999)
Display Intensity: Eight user selectable intensity levels
Programming Methods: Four SafeTouch through-glass buttons when cover is installed. Four internal push buttons when cover is removed.
Noise Filter: Programmable 2 to 199 (0 will disable filter)
Display Update Rate: Process/RTD: 3.7-5/sec; TC: 1.8-2.5/sec
Overrange: Display flashes 9999
Underrange: Display flashes -1999
Recalibration: All inputs are calibrated at the factory; recalibration is recommended at least every 12 months.
Max/Min Display: Stored until reset by user or meter is turned off.
Password: Restricts modification of programmed settings.
Non-Volatile Memory: Settings stored for a minimum of 10 years.
Power Options: 85-265 VAC, 50/60 Hz; 90-265 VDC, 20 W max or 12-36 VDC; 12-24 VAC, 6 W max.
Required Fuse: UL Recognized, 5 A max, slow-blow; up to 6 meters may share one fuse.
Normal Mode Rejection: 64 dB at 50/60 Hz
Isolation: 4 kV input/output-to-power line; 500 V input-to-output or output-to-24 VDC supplies.
 -6X5 models only: 100 V output-to-24 VDC supply
Environmental:
 T6 Class operating temperature range Ta = -40 to 60°C
 T5 Class operating temperature range Ta = -40 to 65°C
Connections:
Power & Signal: removable screw terminal blocks accept 12 to 22 AWG.
Serial: RJ11 header, standard on all meters.
Enclosure: Explosion-proof die cast aluminum with glass window, corrosion resistant epoxy coating, color: blue. NEMA 4X, 7, & 9, IP68. Default conduit connections: Four 3/4" NPT threaded conduit openings and two 3/4" NPT metal conduit plugs with 12 mm hex key fitting installed. Additional conduit opening configurations may be available; verify quantity and sizes on specific device labeling during installation.
Dimensions: 6.42" x 7.97" x 8.47" (W x H x D)
 (163 mm x 202 mm x 215 mm)
Weight: 16.0 lbs (7.26 kg)
Warranty: 3 years parts & labor
USB Connection: Compatibility: USB 2.0 Standard, Compliant
 Connector Type: Micro-B receptacle
 Cable: USB A Male to Micro-B Cable
 Driver: Windows 98/SE, ME, 2000, Server 2003/2008, XP 32/64-Bit, Vista 32/64-Bit, Windows 7 32/64-Bit, Windows 10 32/64-Bit
 Power: USB Port

Process Inputs

Inputs: 0-20 mA, 4-20 mA, 1-5 V, ±10 V
Accuracy: ±0.05% FS ±1 count; square root: ±0.1% FS ±2 counts
Function: Linear or square root
Low-Flow Cutoff: 0 to 9999 (0 disables cutoff function)
Decimal Point: Up to 3 decimals.
Calibration: Scale without signal or calibrate with signal source
Calibration Range: User programmable over entire range of meter
Input Impedance: Voltage range: greater than 1 MΩ, Current range: 50-100 Ω, varies with resettable fuse impedance
Input Overload: Protected by automatically resettable fuse
Temperature Drift:

	0 to 65° C ambient	-40 to 0° C ambient
Current	±0.20% FS (50 PPM/°C)	±0.80% FS
Voltage	±0.02% FS (1.7 PPM/°C)	±0.06% FS

Transmitter Supply: Isolated, one or two transmitter supplies
 P1: 24 VDC ±10% @ 200 mA max (-10 option)
 P1 & P2: 24 VDC ±10% @ 200 mA & 40 mA max (-20 option)

Temperature Inputs

Inputs: Factory calibrated, field selectable: type J, K, T, or E thermocouples and 100 Ω platinum RTD (0.00385 or 0.00392 curve)

Resolution: 1°; type T: 1° or 0.1°

Cold Junction Reference: Automatic

Temperature Drift: ±2°C maximum

Offset Adjustment: Programmable to ±19.9°. This parameter allows the user to apply an offset value to the temperature being displayed.

Input Impedance: Greater than 100 kΩ

Sensor Break: All relays and alarm status LEDs go to alarm state.

Type	Range	Acc. (0-65°C)	Acc. (-40-0°C)
J	-58° to 1382°F -50° to 750°C	±2°F ±1°C	±5°F ±3°C
K	-58° to 2300°F -50° to 1260°C	±2°F ±1°C	±4°F ±2°C
T	-292° to 700°F -180° to 371°C	±2°F ±1°C	±13°F ±7°C
E	-58° to 1700°F -50° to 927°C	±2°F ±1°C	±11°F ±6°C
RTD	-328° to 1382°F -200° to 750°C	±1°F ±1°C	±5°F ±3°C

Relays

Rating: 2 Form C (SPDT); rated 3 A @ 30 VDC or 3 A @ 250 VAC resistive load; 1/14 HP

(≈ 50 watts) @ 125/250 VAC for inductive loads such as contactors, solenoids, etc.

Deadband: 0-100% FS, user selectable

High or Low Alarm: User may program any alarm for high or low

Relay Operation:

1. Automatic (non-latching) 2. Latching 3. Pump alternation control

Relay Reset: User selectable via front panel buttons or PC

1. Automatic reset only (non-latching)

2. Automatic plus manual reset at any time (non-latching)

3. Manual reset only, at any time (latching)

4. Manual reset only after alarm condition has cleared (latching)

Automatic Reset: Relays reset when input passes the reset point

Manual Reset: Front panel button, MeterView, Modbus registers

Time Delay: 0 to 199 seconds, on and off delays; programmable

Fail-Safe Operation: Programmable, independent for each relay. Relay coils are energized in non-alarm condition. In case of power failure, relays will go to alarm state.

Auto Initialization: When power is applied to the meter, relays will reflect the state of the input to the meter.

Isolated 4-20 mA Transmitter Output

Scaling Range: 1.00 to 23.00 mA; reverse scaling allowed.

Calibration: Factory calibrated 4.00 to 20.00 mA

Accuracy: ±0.1% FS ±0.004 mA

Temperature Drift: 50 PPM/°C

Note: Analog output drift is separate from input drift

Isolation: 500 V input-to-output or output-to-24 VDC supplies; 4 kV output-to-power line

External Power: 35 VDC maximum

Output Loop Resistance: Loop Resistance

Power Supply	Minimum	Maximum
24 VDC	10 Ω	700 Ω
35 VDC (external)	100 Ω	1200 Ω

Serial Communications

Compatibility: EIA-232, and EIA-485 with PDA7232 and PDA7422 Trident adapters.

Protocol: PDC and Modbus RTU

Meter Address: PDC protocol: 0 to 99, Modbus protocol: 1 to 247

Baud Rate: 300 to 19,200 bps

Transmit Time Delay: Programmable 0 to 199 ms

Data: 8 bit (1 start bit, 1 stop bit)

Parity: None (2 stop bits), even, or odd

(Modbus only; PDC protocol does not use parity)

Byte-to-Byte Timeout: 0.01 to 2.54 seconds (Modbus only)

Turn Around Delay: Less than 2 ms (fixed)

Refer to PDC and Modbus Serial Communications Protocol manuals for details.

PD8-765 ProtEX-MAX™ Process & Temperature Meter

Product Ratings and Approvals

FM: Type 4X; IP66

Class I, Division 1, Groups B, C, D
 Class II, Division 1, Groups E, F, G
 Class III, Division 1, T5/T6
 Class I, Zone 1, AEx d, IIC Gb T5/T6
 Zone 21, AEx tb IIIC T90°C; Ta -40°C to +65°C
 T6 Ta = -40°C to +60°C; T5 Ta = -40°C to +65°C
 Certificate Number: 3047283

CSA: Class I, Division 1, Groups B, C, D

Class II, Division 1, Groups E, F, G
 Class III, Division 1
 Class I Zone 1 Ex d IIC
 Zone 21 Ex tb IIIC T90°C
 -40°C < Tamb. < +60°C; Temperature Code T6
 -40°C < Tamb. < +65°C; Temperature Code T5
 Enclosure Type 4X & IP66
 Certificate Number: 2531731

ATEX: II 2 G D

Ex d IIC T* Gb
 Ex tb IIIC T90°C Db IP68
 Ta = -40°C to +*°C
 *T6 = -40°C to +60°C
 *T5 = -40°C to +65°C
 Certificate number: Sira 12ATEX1182

IECEx: Ex d IIC T* Gb

Ex tb IIIC T90°C Db IP68
 Ta = -40°C to +*°C
 *T6 = -40°C to +60°C
 *T5 = -40°C to +65°C
 Certificate Number: IECEx SIR 12.0073

CONNECTIONS

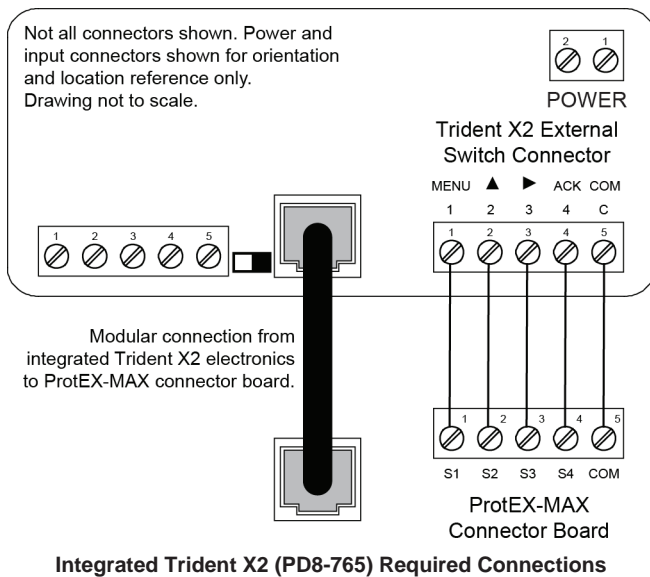

DIMENSIONS

Units: Inches (mm)

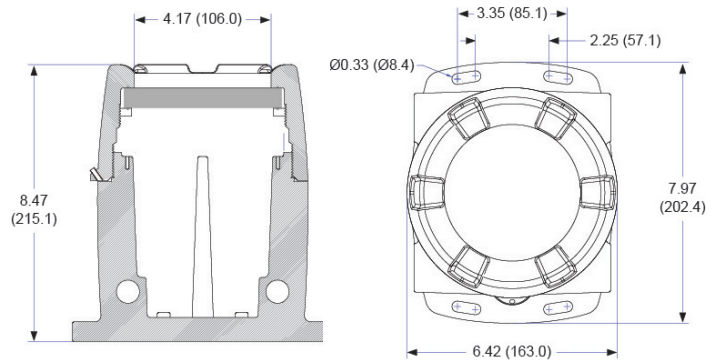

ORDERING INFORMATION

ProtEX-MAX™ PD8-765 Models		
85-265 VAC Model	12-36 VDC Model	Options Installed
PD8-765-6X0-10		24 VDC Supply
PD8-765-6X3-20		4-20 mA Out + Dual 24 VDC Supplies
	PD8-765-7X0-00	None
	PD8-765-7X5-00	2 Relays + 4-20 mA Output
PD8-765-6X5-10		2 Relays + 4-20 mA Output + 24 VDC Supply

WARNING - Cancer and Reproductive Harm - www.P65Warnings.ca.gov

Accessories	
Model	Description
PDA7420	Trident Meter Copy Cable, 7' (2.1 m)
PDA7485-I	RS-232 to RS-422/485 Isolated Converter
PDA8232-N	USB to RS-232 Non-Isolated Converter
PDA8485-I	USB to RS-422/485 Isolated Converter
PDA6846	Pipe Mounting Kit Zinc Plated (Requires 2)
PDA6846-SS	Pipe Mounting Kit Stainless Steel (Requires 2)
PDAPLUG75	3/4" NPT 316 Stainless Steel Stopping Plug with Approvals

Your Local Distributor is:
Order from:
C A Briggs Company
 622 Mary Street; Suite 101
 Warminster, PA 18974
 Phone: 267-673-8117 - Fax: 267-673-8118
Sales@cabriggs.com - www.cabriggs.com

Disclaimer

The information contained in this document is subject to change without notice. Precision Digital Corporation makes no representations or warranties with respect to the contents hereof, and specifically disclaims any implied warranties of merchantability or fitness for a particular purpose.

©2016-18 Precision Digital Corporation. All rights reserved.

LDS8-765_D 12/18