

PD6262 / PD6363

Pro VU® Dual-Input rate/totalizers

PROVU®
SERIES



PD6262 analog Input



PD6363 Pulse Input



flow rate/total

COMMON Pro VU® DUAL- INPUT Meter Features

- rate, total, and Grand total for each Input Channel
- addition, Difference, average, Multiplication, Division, Min, Max, weighted average, ratio, Concentration, & More
- NEMA 4X, IP65 front
- available with Universal 85-265 VAC or 12-24 VDC Input Power
- Large Dual-line 6-Digit Display, 0.60" & 0.46"
- Super-Bright LEDs on Standard and SunBright Display Models
- 2 or 4 relays + Isolated 4-20 mA output options
- external 4-relay, Dual analog output, and Digital I/O expansion Modules
- RS-232, & RS-485 Serial Communications expansion Modules
- on-Board Digital Input
- Modbus® RTU Communication Protocol Standard
- Isolated 24 VDC transmitter Power Supply
- onboard USB and MeterView® Pro Programming Software

PD6262 analog DUAL-INPUT rate/totalizer

- analog Dual-Inputs with Math functions
- 0-20 mA, 4-20 mA, 0-5 V, 1-5 V, and ± 10 V Inputs

PD6363 Pulse Input Dual-INPUT rate/totalizer

- Pulse, open Collector, NPN, PNP, ttl, Switch Contact, Sine wave (Coil), Square wave Inputs
- Gate function for Display of Slow Pulse rates

PD6262 / PD6363 Pro VU® Dual-Input rate/totalizers



UV Resistant
Sunlight Readable Models



Front Panel
NEMA 4X Rated



Large
0.6" Digits

Rugged Front

Dual-Line
6-Character
Display

User Configurable
Display (Showing
custom tag)

PRECISION DIGITAL

User Configurable
Display (Showing
math function result)

Programmable
Function Keys

Alarm Status
Indicators

Perfect for flow and a PPI ICat lo NS

The PD6262 and PD6363 PROVU® meters are multipurpose, easy to use digital dual analog/pulse input flow rate/totalizers specifically designed for displaying flow rate and total from flowmeters with analog or pulse outputs. The displays, relays, and the analog/pulse output may be assigned to the rate, total, or grand total of input channels A or B; or math result channel C. Three of the front panel buttons can be custom-programmed for a specific operation.

Key Features

Dual-Input Process Meter

The PD6262 has two process input channels (A & B) capable of accepting current (0-20, 4-20 mA) and voltage (± 10 , 0-5, 1-5, 0-10 VDC). The PD6363 accepts two pulse (e.g. ± 40 mV to ± 8 V), square wave (0-5 V, 0-12 V, or 0-24 V), open collector, NPN, PNP, TTL or switch contact signals. Each input is programmed separately, with independent input type selection and scaling. These inputs may be displayed individually as part of the customizable dual-line display, or used with a wide range of math functions.

Analog (PD6262)

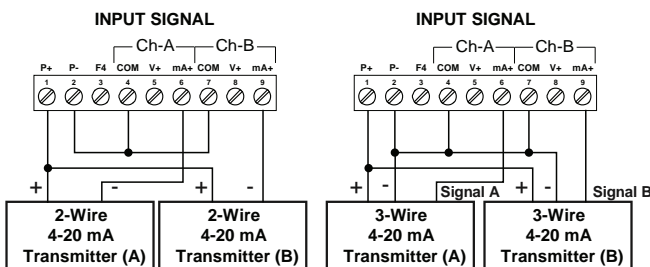

Pulse (PD6363)

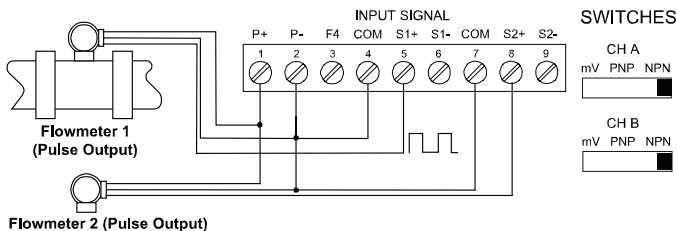

Powerful Math Functions

The PD6262/PD6363 uses two rate input channels (A & B) with total and grand total for each in a variety of powerful math functions designed for a wide range of flow applications. Programmable adder (P) and factor (F) constants allow each formula to be customized as needed for a specific application. The math function (C) may be displayed with units, tags, channel A or B, rate, total or grand total, and in other useful combinations. See **Specifications** for a list of math functions.

Super-Bright LEDs make Standard and SunBright Display Models even Brighter

The PROVU's standard and SunBright display models feature extraordinarily bright LED displays. They are perfect for indoor and outdoor applications where visibility may be impaired by smoke, fog, dust, or distance. The intensity on the SunBright model display is so high it can be read even in the brightest sunlight.

Free USB Programming Software & Cable

The PROVU® comes preloaded with free **MeterView® Pro** programming software that connects and installs directly to your PC with a standard USB cable, also provided free with each instrument. This eliminates the need to insert CDs, install drivers, or download software from the internet. The software will allow you to configure, monitor, and datalog a PROVU® PD6262/6363 using your PC. Just simply connect the meter to your PC with the USB cable and within minutes you will be programming it.

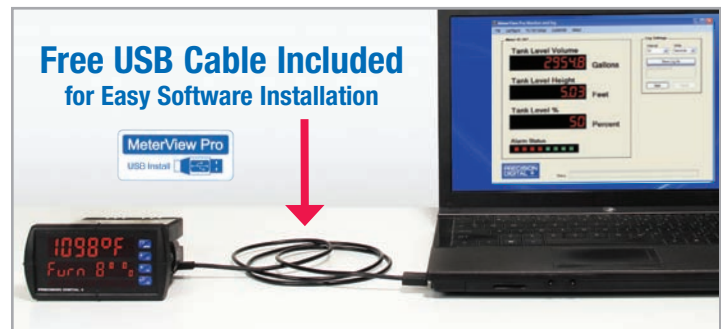

Function Keys

There are three function keys available to the user. These keys can be programmed to trigger certain events (i.e. acknowledge alarms, reset max and/or min, disable/enable output relays, or hold current relay states), provide direct menu access points, and more.



Learn more about using the PROVU's Function Keys by watching a video at predig.com/videos

Customizable Displays

The PROVU has two red LED displays, an Upper display 0.60" (15 mm) high, and a Lower display 0.46" (12 mm) high. Each display is a full 6 digits (-99999 to 999999).

The displays can be set up to read input channels (A or B), rate, total, or grand total, math function channel C, toggle between A & B, B & C, A & C, A & B & C, toggle between channels A, B, or C & units, the max/min of any of the channels, including the math channel (C), set points, or the Modbus input. This allows the display to be setup to display whatever variables are most valuable to the application. Here are just a few examples.



Math function & tag

The Upper display shows the math function result (C). The Lower display shows a custom label, in this case the math function used.



Math function & totals A & B

The Upper display shows the math function result (C). The Lower display alternates between totals A and B, with an indicator for each when being displayed.



Input Channels A & B total

Both input channels are displayed, input A total on the Upper display and input B total on the Lower display. Indicators show A or B to label the display channel.

Totalizer Overflow Displays Total to 9 Digits

These flow rate/totalizers can display up to nine digits of total flow with the total overflow feature. In the diagrams below, the flow totalizer is displaying 532,831,470 by toggling between a display of "oF 532" and "831470". Notice the "oF" stands for overflow.



Simplified & Dynamic Menu System

The PROVU minimizes the menu selections by auto-detecting the installed options to determine what menu navigation is required. For example, extra menu items for the relay expansion module, I/O expansion, etc. are not present unless those options have been installed.



Rugged

A unique front panel design makes the PROVU nearly impenetrable in typical applications. Here, the PROVU easily survives a direct hit on the display from a heavy 2" solid stainless steel ball dropped from eight feet.

Alternating Display

Certain display options alternate the display information. A single display can show input variable information as well as that channel's unit or tag. Input and math function channels, gross and net values, and select inputs and the math result may also alternate on a single display. Below are just a few of the options for setting up a single display to alternate information.



Lower Display Alternating Input Channels A & B alternating A & B totals on the Bottom



Top and Bottom Displays Alternating Channel A & B totals

Environmentally Protected

The PROVU has standard UV protection, a NEMA 4X front panel, extremely durable face plate, performs in a wide ambient operating temperatures, and is CE Certified (high noise and RF immunity).

DIGIt al CoMMUNICatIoNS

Modbus® r t U Serial Communications

With the purchase of a serial communication adapter, PROVU meters can communicate with any Modbus Master device using the ever-popular Modbus communications protocol that is included in every PROVU. This greatly increases the flexibility of the meter.

Meter View® Pro Software are

Configure, monitor, and datalog a PD6262/PD6363 from a PC using Meter View Pro Software (available with each PROVU meter via USB or for download at www.predig.com).

Field eXPANsION MoDULeS

Add functionality to the PROVu in the field with easy-to-install external expansion modules. Add USB, RS-232, or RS-485 communications, I/O modules (up to 2), dual analog output module, and 4-relay expansion module.



The menu items for these modules do not appear until the module is connected, simplifying the basic menu. Relay and digital I/O modules are shown above with optional DIN rail mounting kit, P/N PDA1002.

PDA1004 relay expansion Module

An external module containing four 3 A Form A (SPST) relays can be added to the PROVu at anytime. Removable screw terminal blocks accept 12 to 22 AWG wire.

PDA1011 Dual analog output expansion Module

The PDA1011 is a dual analog output expansion module that is connected to the meter using a CAT5e cable provided with each module. For the PROVu to recognize installed PDA1011 analog outputs the module must be connected by the M-Link connector to the PROVu and each analog output to be used must be wired to and powered by a separate DC supply powering the PROVu. *Note: Works with dual-input meters only.*

PDA1044 I/O expansion Module

Four digital inputs and four digital outputs are available per expansion module. The PROVu meter will accept two of these modules. External digital inputs can function similarly to the front panel function keys or on-board digital input F4. They can be configured to trigger certain events (i.e. acknowledge/reset alarms, reset max and/or min values, disable/enable all output relays, and hold current relay states), provide direct menu access point, or mimic front panel keys. The I/O module can be used to configure the PROVu remotely, in essence giving the user control of the four front panel push buttons. This feature is particularly useful if the meter is mounted inside an explosion-proof enclosure.

Digital outputs can be used to remotely monitor PROVu's alarm relay output states, or the states of a variety of actions and functions executed by the meter.

PDA1232 & PDA1485 Communication Modules

Serial communications on the PROVu can be added anytime with external PDA1232 (RS-232) or PDA1485 (RS-485) communication adapters.

OutputS

analog outputs

Each isolated analog retransmission signal can be configured to represent the channel A or B rate/process variable (PV), total, grand total, maximum (peak) value or minimum (valley) value; Channel C; math value; or the value for any of the eight relay set points, manual setting control, or Modbus input. While the output is nominally 4-20 mA, the signal will accurately accommodate under and over ranges from 1 to 23 mA.

relay outputs

The PROVu has up to four 3 A Form C relays (SPDT) with multiple power loss fail-safe options. Each relay may be assigned to input channel A or B, rate, total or grand total, or math result (C). Relays can be configured for proper protective action upon input loop break. Relay ON and OFF delay times are user adjustable. Up to eight front panel indicators show alarm and/or relay state. All relays can be configured for 0-100% deadband.

Relay Operation/Configuration

There are powerful relay functions that can be configured in the PROVu meter, including:

- Automatic reset only (non-latching)
- Automatic + manual reset at any time (non-latching)
- Latching (manual reset only)
- Latching with clear (manual reset only after alarm condition has cleared)
- Pump alternation control (automatic reset only)
- Sampling (activated for a user-specified time)
- User selectable fail-safe operation
- Relay action for loss (break) of 4-20 mA input signal
- Time delay (on and off), independent for each relay
- Manual control mode
- Interlock relay mode

Interlock relay(s)

This function allows a process to use one or more very low voltage input signals or simple switch contacts to control the state of one or more internal "interlock" relays. A violation (i.e. loss of input, open switch, or open circuit) forces one or more N/O interlock relay contacts to open. One input can be used in series with a number of interlock switches, or up to eight inputs can be required to force-on one (or more) internal interlock relays. Requires PDA1044 Digital I/O module or use of on-board digital input F4. Please see *Safety Interlock on the ProVu Series* white paper on our website for more information.

Sampling function (PV triggered timed relay)

The sampling function allows the operator to set a set point for a "sampling" relay. When the process (rate or total) reaches that set point, it will close that relay's contacts for a preset period of time (0.1 to 5999.9 seconds). An example of its use may be for wastewater sampling. When the wastewater total reaches a preset total interval (i.e. every 10,000 gallons), the relay contacts would close for a preset time, and by some means (light, horn, etc.) alert someone to take a sample, or provide the trigger to automatically take a sample of the wastewater. The utility of this function can, of course, be expanded beyond sampling and be used whenever a timed relay output closure is required when the rate or a total interval reaches a certain set point.

Manual output Control

Take control of any output with this feature. All relays can be forced ON or OFF, and the 4-20 mA output signal can be set to any value within its range. When the relays and 4-20 mA output are controlled manually, an LED labeled "M" is turned on and the associated Alarm LEDs (1-8) flash every 10 seconds indicating that the meter is in manual control mode.



totalizer Capabilities

PROVu flow rate/totalizers can be programmed for a wide variety of totalizer applications. Each input channel has a total, grand total, or non-resettable grand total with a time base of seconds, minutes, hours or days. The user can program a totalizer conversion factor for each channel, a non-resettable grand total, password protection, and several total reset methods.

Non-resettable Grand total

The user can set up the grand totals to be non-resettable by entering a specific password. Once this is done, the grand total can never be reset for either input channel.

totalizer Conversion factors

The user can enter a totalizer conversion factor for each channel that allows the meter to display total in different units than the rate. For instance, a meter could display flow rate in gallons per minute and total in hundredths of acre-feet.

totalizer Password Protection

The totals and grand totals can be password protected so they can be reset only by authorized personnel.

remote total reset

An I/O expansion module or F4 digital input can be used to remotely reset the totals or grand totals. The reset switch is wired into the module or F4 input and the module is connected to the M-Link RJ45 connector at the back of the flow rate/totalizer.

total alarms

The PROVu's four internal and four external relays can be set up to alarm when the total of channel A or B, or channel C math based on the totals, reaches a user-defined set point. A variety of reset modes are available and the user can also program time delays and fail-safe operation.

front Panel total reset

The three front panel function keys can be programmed to reset the totals and grand totals. This makes it possible for the user to reset either the totals or the grand totals by pressing the appropriate function key. Of course, if the totals or grand totals are password protected, they will not reset when the function key is pressed.



NEMA 4 & 4X flexible Enclosure Sure S

Thermoplastic and stainless steel NEMA 4X, and painted steel NEMA 4 enclosures for up to 10 PROVu meters are available. Visit our website at www.predig.com for more information.



PDa 2811
Plastic Low-Cost

PDa 2302
Plastic Economical

PDa 2604
Stainless Steel

Application Notes

Differential Pressure flow (PD6262)

The PD6262 can display flow rate and total by extracting the square root from the 4-20 mA signal from differential pressure transmitters. The user selectable low-flow cutoff feature gives a reading of zero when the flow rates drop below a user selectable value.

- Display Flow Rates and Totals
- User Selectable Low-Flow Cutoff
- Only 2 Calibration Points Required

Open Channel flow (PD6262)

The PD6262, in combination with ultrasonic level transmitters, makes for an economical way to measure and display open channel flow rates and totals in most weirs and flumes, and take periodic samples. All the user needs to do is enter the exponents for the weirs or flumes into the PD6262 and the PD6262 automatically raises the input signals to those powers. Sampling can be based on the total flow or the flow rate. Each channel's signal input conditioning is programmed independently.

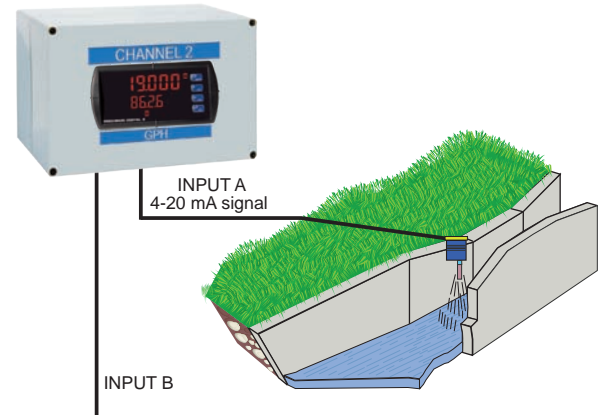

weir flow Calculated Using exponential Signal Input Conditioning

Convert Pulses to 4-20 ma (PD6363)

The PD6363 accepts pulse outputs from flowmeters and with the appropriate option installed, can convert the pulses to a 4-20 mA signal. The 4-20 mA signal can be programmed to correspond to either the flow rate or the total flow.

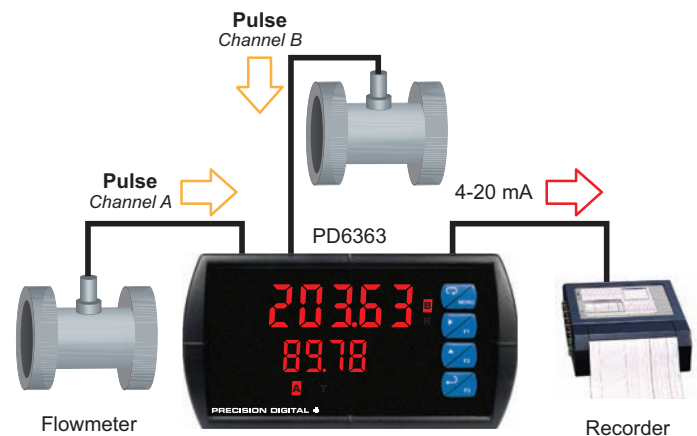

- Use K-Factor or Multi-Point Scaling
- PROVu Powers the Flowmeters
- Up to 3 Analog Outputs

PD6262 / PD6363 Pro Vu® Dual-Input rate/totalizers

Connections

PD6262

- Form C (SPDT) relays
- Two isolated power supplies available even on 12/24 VDC input power models
- Removable terminal blocks
- 2 or 4 relays + isolated 4-20 mA output option

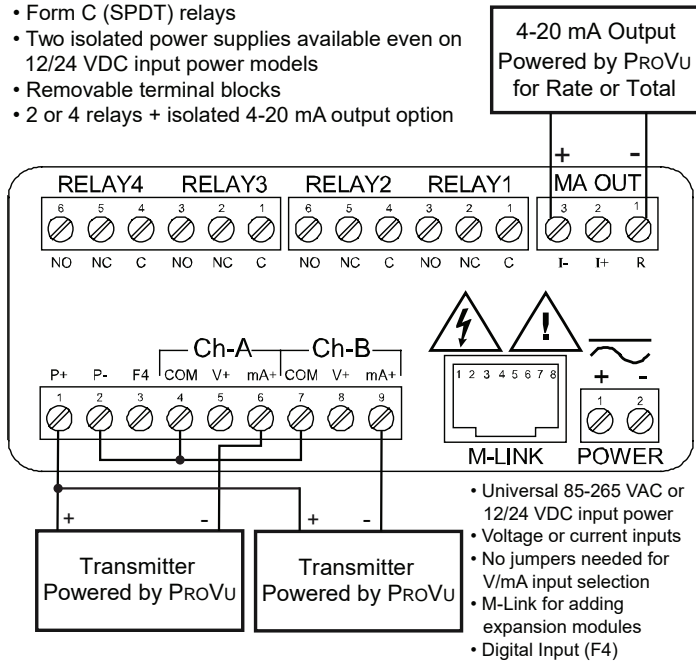

PD6363

- Form C (SPDT) relays
- Two isolated power supplies available even on 12/24 VDC input power models
- Removable terminal blocks
- 2 or 4 relays + isolated 4-20 mA output option

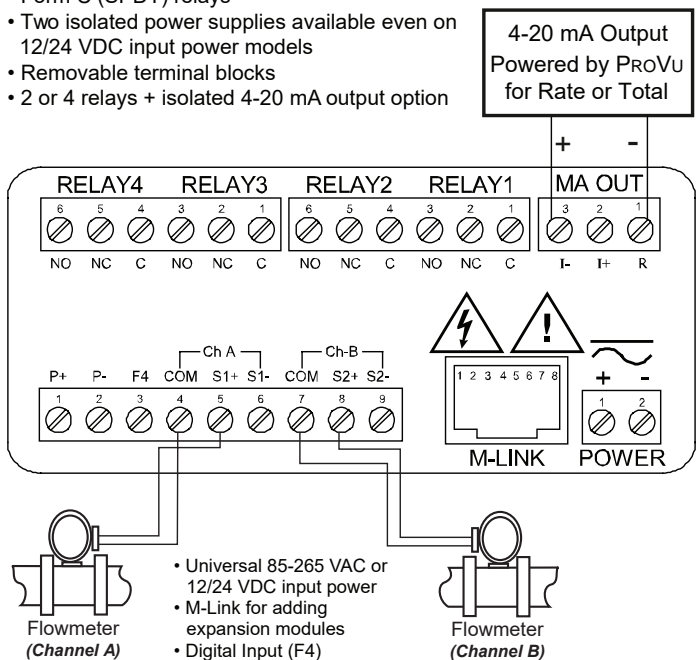

Specifications

Except where noted all specifications apply to operation at +25°C.

General

Display: Upper display: 0.60" (15 mm) high. Lower display: 0.46" (12 mm) high. 6 digits each (-99999 to 999999), red LEDs with lead zero blanking.

Display Intensity: Eight user selectable intensity levels

Display Update Rate: PD6262: 5/second (200 ms) PD6363: Rate: 10 per second; up to 1 per 100 seconds (and is a function of Low Gate setting); Total: 10 per second (fixed)

Overrange: Display flashes 999999

Underrange: Display flashes -99999

Display assignment: The Upper and Lower displays may be assigned to show: One or more rate channels: Channel A (Ch-A), B (Ch-B), or C (Ch-C), Toggle between rate channels: Ch-A & Ch-B, Ch-A & Ch-C, Ch-B & Ch-C, and Ch-A, Ch-B, & Ch-C, Total or grand total: Ch-A or Ch-B, Rate and total or grand total: Ch-A, Ch-B, Relay set points, Max and/or min values: Ch-A, Ch-B, or Ch-C, Toggle between any rate channel & units, Toggle between any rate/math channel & units, Total and units: Ch-A or Ch-B, Toggle between totals: Ch-A & Ch-B; Ch-A, Ch-B, and sum of Ch-A and Ch-B, Modbus input. The lower display may also be set to show engineering units or be off, with no display.

Programming Methods: Four front panel buttons, digital inputs, PC and MeterView Pro software, Modbus registers, or cloning using Copy function.

Max/Min Display: Max/min readings reached by the process are stored until reset by the user or until power to the meter is cycled.

Password: Three programmable passwords restrict modification of programmed settings and two prevent resetting the totals.

Noise filter: (PD6262) Programmable from 2 to 199 (0 will disable filter)

filter Bypass: (PD6262) Programmable from 0.1 to 99.9% of calibrated span

Non-Volatile Memory: All programmed settings are stored in non-volatile memory for a minimum of ten years if power is lost.

Recalibration: All ranges are calibrated at the factory. Recalibration is recommended at least every 12 months.

Power options: 85-265 VAC 50/60 Hz, 90-265 VDC, 20 W max, or optional model with 12-24 VDC $\pm 10\%$, 15 W max.

Fuse: Required external fuse: UL Recognized, 5 A max, slow blow; up to 6 meters may share one 5 A fuse.

Isolated Transmitter Power Supply: Terminals P+ & P-: 24 VDC $\pm 10\%$. Internally selectable jumper for 24, 10, or 5 VDC supply.

85-265 VAC models rated @ 200 mA max, 12-24 VDC powered models rated @ 100 mA max, @ 50 mA max for 5 or 10 VDC supply.

Normal Rejection Mode: (PD6262) Greater than 60 dB at 50/60 Hz

Isolation: 4 kV input/output-to-power line. 500 V input-to-output or output-to-P+ supply.

Overvoltage Category: Installation Overvoltage Category II: Local level with smaller transient overvoltages than Installation Overvoltage Category III.

Environmental: Operating temperature range: -40 to 65°C

Storage temperature range: -40 to 85°C

Relative Humidity: 0 to 90% non-condensing

Connections: Removable screw terminal blocks accept 12 to 22 AWG wire, RJ45 for external relays, digital I/O, and serial communication adapters.

Enclosure: 1/8 DIN, high impact plastic, UL 94V-0, color: black

Mounting: 1/8 DIN panel cutout required: 3.622" x 1.772"

(92 mm x 45 mm). Two panel mounting bracket assemblies are provided.

Tightening Torque: Screw terminal connectors: 5 lb-in (0.56 Nm)

Dimensions: 4.68" x 2.45" x 5.64" (119 mm x 62 mm x 143 mm) (W x H x D)

Weight: 9.5 oz (269 g)

Warranty: 3 years parts & labor

USB Connection: Compatibility: USB 2.0 Standard, Compliant

Connector Type: Micro-B receptacle

Cable: USB A Male to Micro-B Cable

Driver: Windows 98/SE, ME, 2000, Server 2003/2008, XP 32/64-Bit,

Vista 32/64-Bit, Windows 7 32/64-Bit, Windows 10 32/64-Bit

Power: USB Port

Dual Input functionality

Analog Inputs: (PD6262) Two non-isolated inputs, each separately field selectable: 0-20, 4-20 mA, ± 10 V (0-5, 1-5, 0-10 V), Modbus PV (Slave)

Pulse Inputs: (PD6363) Two, Field selectable: Pulse or square wave 0-5 V, 0-12 V, or 0-24 V @ 30 kHz; TTL; open collector 4.7 k Ω pull-up to 5 V @ 30 kHz; NPN or PNP transistor, switch contact 4.7 k Ω pull-up to 5 V @ 40 Hz; Modbus PV (Slave)

Channels: Channel A, Channel B, Channel C (Math channel)

Programmable Constants: Constant P (Adder): -99.999 to 999.999, default: 0.000, Constant F (Factor): 0.001 to 999.999, default: 1.000

Low Voltage Mag Pickup: (PD6363) Sensitivity: 40 mVp-p to 8Vp-p

Minimum Input Frequency: (PD6363) 0.001 Hz Minimum frequency is dependent on high gate setting.

Maximum Input Frequency: (PD6363) 30,000 Hz (10,000 for low voltage mag pickup)

Accuracy: (PD6262) $\pm 0.03\%$ of calibrated span ± 1 count, square root & programmable exponent accuracy range: 10-100% of calibrated span (PD6363) $\pm 0.03\%$ of calibrated span ± 1 count

Math functions:

Name	Function	Setting
Addition	$(A+B+P)*F$	SURR
Difference	$(A-B+P)*F$	d iF
Absolute diff.	$((\text{Abs}(A-B))+P)*F$	d iFRb5
Average	$((A+B)/2+P)*F$	RiUG
Multiplication	$((A*B)+P)*F$	rruL t
Division	$((A/B)+P)*F$	d iU dE
Max of A or B	$((\text{AB-Hi})+P)*F$	H i-Ab
Min of A or B	$((\text{AB-Lo})+P)*F$	Lo-Ab
Draw	$((A/B)-1)*F$	d-rAuU
Weighted avg.	$((B-A)*F)+A$	uL RiUG
Ratio	$(A/B)*F$	rRt io
Ratio 2	$((B-A)/A+P)*F$	rRt io2
Concentration	$A/(A+B)*F$	ConcEn
Total Addition	$(tA+tB+P)*F$	SURR t
G. Tot. Addition	$(GtA+GtB+P)*F$	SURR tE
Total Difference	$(tA-tB+P)*F$	d iF t
G. Tot. Difference	$(GtA-GtB+P)*F$	d iF tE
Total Ratio	$(tA/tB)*F$	t-rRt io
Total Ratio 2	$((tB-tA)/tA)*F$	t-rRt io2
Total Percent	$(tA/(tA+tB))*100$	t P t

Note: The F constant can be any value from 0.001 to 999.999. If the value is less than 1, it will have the same effect as a divider. For example, the average could also be derived by using $(A+B)/F$, where $F = 0.500$.

Sequence of operations for Input Programming:

1. Select Input for A and B
2. Set up the rate, total, and grand total engineering units for channels A & B, and units for math channel C
3. Set up rate, total, and grand total decimal points for channels A & B, and decimal point for math channel C
4. Program channel A & B rate parameters
5. Program channel A & B total and reset parameters
6. Set up the big and little displays and display intensity
7. Select the transfer function for A & B (e.g. Linear)
8. Select Math function for Channel C
9. Program constants for Factor (F) and Adder (P)
10. Program cutoff values for A and B

Temperature Drift: 0.005% of calibrated span/ $^{\circ}\text{C}$ max from 0 to 65 $^{\circ}\text{C}$ ambient, 0.01% of calibrated span/ $^{\circ}\text{C}$ max from -40 to 0 $^{\circ}\text{C}$ ambient (PD6363) Rate display is not affected by changes in temperature.

Signal Input Conditioning: (PD6262) Linear, square root, programmable exponent.

Multi-Point Linearization: 2 to 32 points for channel A and B

Programmable exponent: (PD6262) 1.0001 to 2.9999

Low-F Low Cutoff: 0-999999 (0 disables cutoff function)

Decimal Point: Up to five decimal places or none: ddddd, ddddd, ddddd, ddddd, or ddddd.

Calibration range (PD6262):

Input Range	Minimum Span
Range	Input 1 & Input 2
4-20 mA	0.15 mA
± 10 V	0.10 V

An Error message will appear if input 1 and input 2 signals are too close together.

Calibration range (PD6363): Input 1 signal may be set anywhere in the range of the meter; input 2 signal may be set anywhere above or below input 1 setting. Minimum input span between any two inputs is 10 Hz. An error message will appear if the input span is too small.

Calibration: (PD6363) May be calibrated using K-factor, internal calibration, or by applying an external calibration signal.

Input Impedance: (PD6262) Voltage ranges: greater than 500 K Ω . Current ranges: 50 - 100 Ω (depending on resettable fuse impedance).

Input overload: (PD6262) Current input protected by resettable fuse, 30 VDC max. Fuse resets automatically after fault is removed.

K-factor: (PD6363) Field programmable K-factor converts input pulses to rate in engineering units. May be programmed from 0.00001 to 999,999 pulses/unit.

Filter: (PD6363) Programmable contact de-bounce filter: 40 to 999 Hz maximum input frequency allowed with low speed filter.

Time Base: (PD6363) Second, minute, hour, or day

Gate: (PD6363) Low gate: 0.1-99.9 seconds, High gate: 2.0-999.9 seconds

4 Digital Input Contacts: 3.3 VDC on contact. Connect normally open contacts across F4 to COM.

4 Digital Input Logic Levels: Logic High: 3 to 5 VDC, Logic Low: 0 to 1.25 VDC

Dual rate/totalizer

Rate Display Indication: 0 to 999999, lead zero blanking.

Total Display & Total Overflow: 0 to 999,999; automatic lead zero blanking. Up to 999,999,999 with total-overflow feature. "oF" is displayed to the left of total overflow.

Total Decimal Point: Up to five decimal places or none: ddddd, ddddd, ddddd, ddddd, ddddd. Total decimal point is independent of rate decimal point. Channel A and B decimal points programmed independently.

Dual Totalizer: Calculates total for channels A and B based on rate and field programmable multiplier to display total in engineering units. Time base must be selected according to the time units in which the rate is displayed. Channel A and B totalizer parameters programmed independently.

Totalizer rollover: Totalizer rolls over when display exceeds 999,999,999. Relay status reflects the display value.

Total Overflow Override: Program total A or B total reset for automatic with 0.1 second delay and set point 1 for 999,999

Totalizer Alarm Presets: Up to eight, user selectable under setup menu. Any set point can be assigned to channel A or B total or grand total (or C) and may be programmed anywhere in the range of the meter for total alarm indication.

Total & Grand Total Reset: Via front panel button, external contact closure on digital inputs, automatically via user selectable preset value and time delay, or through serial communications. Channel A and B total and grand total reset parameters programmed independently.

Total Reset Password: Total and grand total passwords may be entered to prevent resetting the total or grand total from the front panel.

Non-Resettable Total: The grand totals can be programmed as non-resettable totals by entering the password "050873". Both channels are set to non-resettable when this password is entered.

Caution: Once the Grand Total has been programmed as "non-resettable" the feature cannot be disabled.

Programmable Delay on Release: 0.1 and 999.9 seconds; applied to the first relay assigned to total or grand total. If the meter is programmed to reset total to zero automatically when the preset is reached, then a delay will occur before the total is reset.

Relays

Rating: 2 or 4 SPDT (Form C) internal and/or 4 SPST (Form A) external; rated 3 A @ 30 VDC and 125/250 VAC resistive load; 1/14 HP (≈ 50 W) @ 125/250 VAC for inductive loads

Noise Suppression: Noise suppression is recommended for each relay contact switching inductive loads.

Relay Assignment: Relays may be assigned to channel A or B rate, total, or grand total; channel C; or Modbus control.

Deadband: 0-100% of span, user programmable

High or Low Alarm: User may program any alarm for high or low trip point. Unused alarm LEDs and relays may be disabled (turned off).

Relay Operation: automatic (non-latching), latching (requires manual acknowledge), sampling (based on time), pump alternation control (2 to 8 relays), off (disable unused relays), and manual on/off control mode.

Relay Reset: User selectable via front panel buttons, digital inputs, or PC

1. Automatic reset only (non-latching), when input passes the reset point.
2. Automatic + manual reset at any time (non-latching).
3. Manual reset only, at any time (latching).
4. Manual reset only after alarm condition has cleared (latching).

Note: Front panel button or digital input may be assigned to acknowledge relays programmed for manual reset.

Time Delay: 0 to 999.9 seconds, on & off relay time delays. Programmable and independent for each relay.

Fail-Safe Operation: Programmable and independent for each relay.

Note: Relay coil is energized in non-alarm condition. In case of power failure, relay will go to alarm state.

Auto Initialization: When power is applied to the meter, relays will reflect the state of the input to the meter.

PD6262 / PD6363 Pro VU® Dual-Input rate/totalizers

Isolated 4-20 mA transmitter output

output Source: Input channels A or B, rate, total, or grand total; channel C; max or min for channel A or B; highest or lowest max or min of A and B; set points 1-8; Modbus input; or manual control mode.

Scaling range: 1.000 to 23.000 mA for any display range

Calibration: Factory calibrated: 4.000 to 20.000 = 4-20 mA output

analog output Programming: 23.000 mA maximum for all parameters: Overrange, underrange, max, min, and break

accuracy: ± 0.1% of span ± 0.004 mA

temperature Drift: 0.4 µA/°C max from 0 to 65°C ambient,

0.8 µA/°C max from -40 to 0°C ambient

Note: Analog output drift is separate from input drift.

Isolated transmitter Power Supply: Terminals I+ & R: 24 VDC ± 10%.

Isolated from the input at >500 V. May be used to power the 4-20 mA output or other devices. All models rated @ 40 mA max.

external loop Power Supply: 35 VDC maximum

output loop resistance:

Power supply	Minimum	Maximum
24 VDC	10 Ω	700 Ω
35 VDC (external)	100 Ω	1200 Ω

Serial Communications

Protocol: Modbus® RTU

Meter address/Slave ID: 1 - 247

Baud rate: 300 - 19,200 bps

transmit time Delay: Programmable between 0 and 199 ms

Data: 8 bit (1 start bit, 1 or 2 stop bits)

Parity: Even, odd, or none with 1 or 2 stop bits

Byte-to-Byte time out: 0.01 - 2.54 seconds

turn around Delay: Less than 2 ms (fixed)

Note: Refer to the ProVU® Modbus Register Tables located at www.predig.com for details.

Digital I/o expansion Module

Channels: 4 digital inputs & 4 digital outputs per module

System: Up to 2 modules for a total of 8 inputs & 8 outputs

4-relay expansion Module

relays: Four Form A (SPST) rated 3 A @ 30 VDC and 125/250 VAC resistive load; 1/14 HP (≈ 50 watts) @ 125/250 VAC for inductive loads.

Dual analog output expansion Module

outputs: Two passive 4-20 mA analog outputs

Scaling range: 3.000 to 23.000 mA for any display range

DIMENSIONS

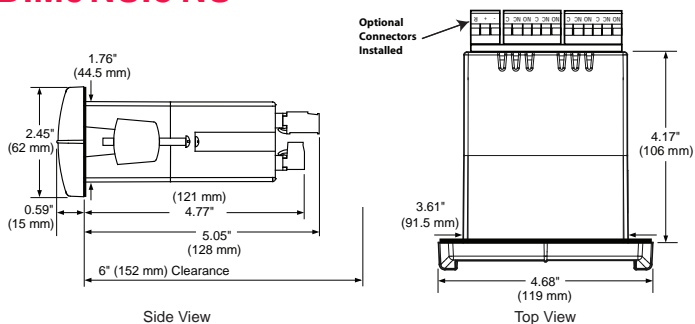

Notes:

1. Panel cutout required: 1.772" x 3.622" (45mm x 92mm)
2. Panel thickness: 0.040 - 0.250" (1.0mm - 6.4mm)
3. Mounting brackets lock in place for easy mounting
4. Clearance: Allow 6" (152 mm) behind the panel

Ordering Information

Pro VU® PD6262 analog Inputs		
85-265 Va C Model	12-24 VDC Model	options Installed
PD6262-6R0	PD6262-7R0	None
PD6262-6R2	PD6262-7R2	2 Relays
PD6262-6R3	PD6262-7R3	4-20 mA Output
PD6262-6R4	PD6262-7R4	4 Relays
PD6262-6R5	PD6262-7R5	2 Relays & 4-20 mA Output
PD6262-6R7	PD6262-7R7	4 Relays & 4-20 mA Output

To order SunBright display models replace the "R" with "H" (i.e. PD6262-6H2)
Note: 24 V flowmeter power supply standard on all models.

Pro VU® PD6363 Pulse Inputs		
85-265 Va C Model	12-24 VDC Model	options Installed
PD6363-6R0	PD6363-7R0	None
PD6363-6R2	PD6363-7R2	2 Relays
PD6363-6R3	PD6363-7R3	4-20 mA Output
PD6363-6R4	PD6363-7R4	4 Relays
PD6363-6R5	PD6363-7R5	2 Relays & 4-20 mA Output
PD6363-6R7	PD6363-7R7	4 Relays & 4-20 mA Output

To order SunBright display models replace the "R" with "H" (i.e. PD6363-6H2)
Note: 24 V flowmeter power supply standard on all models.

Accessories	
Model	Description
PDA1002	DIN Rail Mounting Kit for Two Expansion Modules
PDA1004	4-Relay Expansion Module
PDA1011	Dual Isolated 4-20 mA output expansion module
PDA1044	4 Digital Inputs & 4 Digital Outputs Module
PDA1232	RS-232 Serial Adapter
PDA1485	RS-485 Serial Adapter
PDA7485-I	RS-232 to RS-422/485 Isolated Converter
PDA7485-N	RS-232 to RS-422/485 Non-Isolated Converter
PDA8232-N	USB to RS-232 Non-Isolated Converter
PDA8485-I	USB to RS-422/485 Isolated Converter
PDA8485-N	USB to RS-422/485 Non-Isolated Converter
PDX6901	Suppressor (snubber): 0.01 µF/470 Ω, 250 VAC

Your Local Distributor is:

Order from:

C A Briggs Company

622 Mary Street; Suite 101
Warminster, PA 18974

Phone: 267-673-8117 - Fax: 267-673-8118

Sales@cabriggs.com - www.cabriggs.com

Disclaimer

The information contained in this document is subject to change without notice. Precision Digital Corporation makes no representations or warranties with respect to the contents hereof, and specifically disclaims any implied warranties of merchantability or fitness for a particular purpose. ©2010-2017 Precision Digital Corporation. All rights reserved.

LDS6262_D 03/17