

PD6200 / PD6300

PRoVU® Dual-Line 6-Digit Flow Rate/Totalizers



PROVU
SERIES

SUPER-BRIGHT LEDs
Our Brightest Display Ever

MeterView Pro
USB Install



Flow Rate/Total

Common PRoVU® mETER FEaTURES

- nEma 4X, IP65 Front
- Input Power options Include 85-265 Va C or 12-24 VDC
- Dual-Line 6-Digit Display, 0.60" & 0.46"
- Programmable Displays & Function Keys
- optional sunBright Display models for outdoor applications
- 2 or 4 Relays + Isolated 4-20 ma output options
- External 4-Relay & Digital I/o Expansion modules
- Rs-232, & Rs-485 serial Communications
- on-Board Digital Input
- modbus® RTU Communication
- on-board USB and meterView® Pro Programming software

Common RaTE/ToTaLizER FEaTURES

- Display Rate & Total at the same Time
- Rate in Units per second, minute, Hour, or Day
- Total, Grand Total or non-Resettable Grand Total
- Password Protection for Total Reset
- 9-Digit Totalizer with Total overflow Feature
- Total stored in non-Volatile memory
- any Relay for Rate or Total
- 4-20 ma output for Rate or Total
- sampling Relay

anaLoG InPUTs

- 0-20 ma, 4-20 ma, 0-5 V, 1-5 V, and ±10 V Inputs
- Isolated 24 VDC @ 200 ma Transmitter Power supply
- open Channel Flow with Programmable Exponent
- square Root Extraction
- 32-Point Linearization

PULsE InPUTs

- Pulse, open Collector, nPn, PnP, TTL, switch Contact, sine wave (Coil), square wave Inputs
- 5, 10 or 24 VDC Flowmeter Power supply
- Gate Function for Rate Display of slow Pulse Rates
- K-Factor, Internal scaling, or External Calibration
- 4-20 ma output option Converts the Pulse Input to an Isolated 4-20 ma output

PRECISION DIGITAL CORPORATION

**PRECISION
DIGITAL**

www.CABriggs.com

PD6200 / PD6300 ProVu® Flow Rate/Totalizers



UV Resistant
Sunlight Readable Models



Front Panel
NEMA 4X Rated



PERFECT FoR Flow aPPLICaTions

The PD6200 and PD6300 ProVu® meters are 1/8 DIN flow rate/totalizers specifically designed for displaying flow rate and total from flowmeters with analog or pulse outputs. These flow rate/totalizers are particularly well-suited for flow applications because they can display flow rate and flow total at the same time, provide power to drive the flowmeter, and display flow total, flow grand total, or non-resettable flow total on up to nine digits.

KEY FEaTURES

Display Flow Rate, Total or Grand Total

The upper display can be programmed to display flow rate, total, or grand total, and the lower display can be programmed to display flow rate, total, grand total, engineering units, custom legends, or can be turned off. Both displays could also display relay set points, or max and min values.

In the graphic at the top of the page, the upper display is displaying flow rate (as indicated by the "R" to the right of the number) and the lower display is displaying flow grand total (as indicated by the "G" & "T" under the number.) The following photographs show typical ways these flow rate/totalizers can be programmed.

super-Bright LEDs make standard and sunBright Display models Even Brighter

The ProVu's standard and SunBright display models feature extraordinarily bright LED displays. They are perfect for indoor and outdoor applications where visibility may be impaired by smoke, fog, dust, or distance. The intensity on the SunBright model display is so high it can be read even in the brightest sunlight.



Rugged

A unique front panel design makes the ProVu nearly impenetrable in typical applications. Here, the ProVu easily survives a direct hit on the display from a heavy 2" solid stainless steel ball dropped from eight feet.

Free UsB Programming software & Cable

The ProVu® comes preloaded with free **meterView® Pro** programming software that connects and installs directly to your PC with a standard USB cable, also provided free with each instrument. This eliminates the need to insert CDs, install drivers, or download software from the internet. The software will allow you to configure, monitor, and datalog a ProVu® PD6200/PD6300 using your PC. Just simply connect the meter to your PC with the USB cable and within minutes you will be programming it.

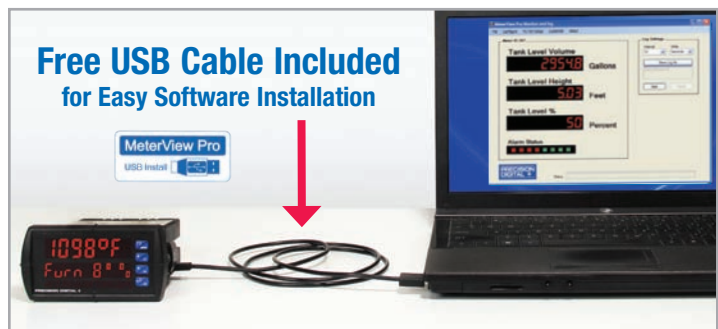

Flow Rate Indicator



Flow Totalizer



Rate & Total



Total & Grand Total

Easy to Use

The user friendly dual-line display makes the ProVu easy to set up & program. No jumpers to set for input selection. All setup & programming are done via the front panel.



Input setup



Display setup

Totalizer Overflow Displays Total to 9 Digits

These flow rate/totalizers can display up to nine digits of total flow with the total overflow feature. In the diagrams below, the flow totalizer is displaying 532,831,470 by toggling between a display of "oF 532" and "831470". Notice the (T with arrow ▲ symbol) is lit up indicating the display is in overflow mode.



On-Board Digital Input

The PD6200 and PD6300 include a digital input as standard. This digital input can operate with the tare, reset tare, or interlock relays feature, force relays on from a signal from a PLC or relay on other equipment, and much more. This is ideal for installations where the meter is inaccessible behind a cover, or where an additional function key is needed for customized operation.

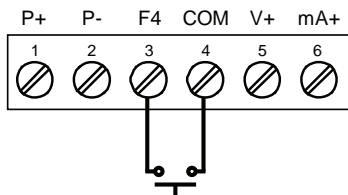

Rounding

The rounding feature is used to give the user a steadier display with fluctuating signals. It causes the display to round to the nearest value according to the rounding value selected (1, 2, 5, 10, 20, 50, or 100). For example, with a rounding value of 10, and a input of 12346, the display would indicate 12350.

Three Tier Password Protection

The ProVu offers 3 levels of password protection:

- Level 1 protection allows the operator use of only the 3 pre-configured function keys on the front panel without a password.
- Level 2 protection allows the operator use of only the function keys and the ability to change set points without a password.
- Level 3 protection restricts the operator from using the function keys and all meter configuration menus without a password.

To TaLizER Ca PaBILITIEs

ProVu flow rate/totalizers can be programmed for a wide variety of totalizer applications. They can display total, grand total, or non-resettable grand total with a time base of seconds, minutes, hours or days. The user can program a totalizer conversion factor, a non-resettable grand total, password protection, and several total reset methods.

Totalizer Conversion Factor

The user can enter a totalizer conversion factor that allows the meter to display total in different units than the rate. For instance, a customer could measure flow rate in gallons per minute and total in hundredths of acre-feet.

Totalizer Password Protection

The total and grand total can be password protected so they can be reset only by authorized personnel.



Total Password



Grand Total Password

non-Resettable Grand Total

The user can set up the grand total to be non-resettable by entering a specific password. Once this is done, the grand total can never be reset.

Remote Total Reset

An I/O expansion module can be used to remotely reset the total or grand total. The reset switch is wired into the module and the module is connected to the M-Link RJ45 connector at the back of the flow rate/totalizer.

Total alarms

The ProVu's four internal and four external relays can be set up to alarm when the total reaches a user-defined set point. A variety of reset modes are available and the user can also program time delays and fail-safe operation.

Front Panel Total Reset

The three front panel function keys can be programmed to reset the total and grand total. This makes it possible for the user to reset either the total or the grand total by pressing the appropriate function key. Of course, if the total or grand total is password protected, they will not reset when the function key is pressed.

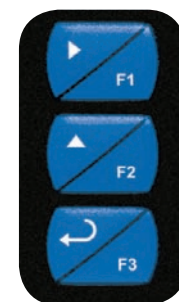

DIGITaL CommUnICaTions

modbus® RTU serial Communications

With the purchase of a serial communication adapter, ProVu meters can communicate with any Modbus Master device using the ever-popular Modbus communications protocol that is included in every ProVu. This greatly increases the flexibility of the meter. Modbus provides much more capability than read PV and write set points.



modbus PV Input



Remote message

mETERVIEW® PRo soFTwaRE

Configure, monitor, and datalog a PD6200/PD6300 from a PC using Meter View Pro Software (available with each PROVU meter via USB or for download at www.predig.com).

FIELD EXPans Ion mo DULES

Add functionality to the PROVU in the field with easy-to-install external expansion modules. Add USB, RS-232, or RS-485 communications, I/O modules (up to 2), and 4-relay expansion module. The menu items for these modules do not appear until the module is connected, simplifying the basic menu. Relay and digital I/O modules are shown below with optional DIN rail mounting kit, P/N PDA1002.



PDa1044 I/o Expansion module

Four digital inputs and four digital outputs are available per expansion module. The PROVU meter will accept two of these modules. External digital inputs can function similarly to the front panel function keys or on-board digital input F4. They can be configured to trigger certain events (i.e. acknowledge/reset alarms, reset max and/or min values, disable/enable all output relays, and hold current relay states), provide direct menu access point, or mimic front panel keys. The I/O module can be used to configure the PROVU remotely, in essence giving the user control of the four front panel push buttons. This feature is particularly useful if the meter is mounted inside an explosion-proof enclosure.

Digital outputs can be used to remotely monitor PROVU's alarm relay output states, or the states of a variety of actions and functions executed by the meter.

PDa1004 Relay Expansion module

An external module containing four 3 A Form A (SPST) relays can be added to the PROVU at anytime. Removable screw terminal blocks accept 12 to 22 AWG wire.

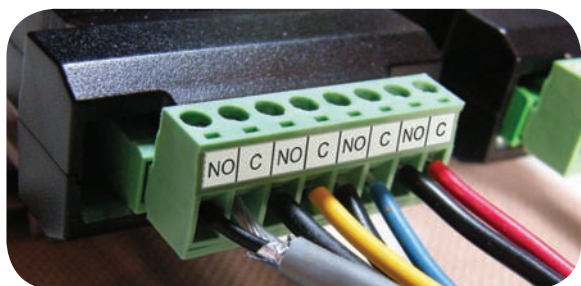

PDa1232 & PDa1485 Communication modules

Serial communications on the PROVU can be added anytime with external PDA1232 (RS-232) or PDA1485 (RS-485) communication adapters.

Free Modbus protocol included for use with PROVU serial communications modules.

o UTPUTs

Relay o utputs

The PROVU has up to four 3 A Form C relays (SPDT) with multiple power loss fail-safe options. Relays can be configured for proper protective action upon input loop break. Relay ON and OFF delay times are user adjustable. Up to eight front panel indicators show alarm and/or relay state. All relays can be configured for 0-100% deadband.

Relay Operation/Configuration

There are powerful relay functions that can be configured in the PROVU meter, including:

- Automatic reset only (non-latching)
- Automatic + manual reset at any time (non-latching)
- Latching (manual reset only)
- Latching with clear (manual reset only after alarm condition has cleared)
- Pump alternation control (automatic reset only)
- Sampling (activated for a user-specified time)
- User selectable fail-safe operation
- Relay action for loss (break) of 4-20 mA input signal
- Time delay (on and off), independent for each relay
- Manual control mode
- Interlock relay mode

analog o utput

The isolated analog retransmission signal can be configured to represent the rate/process variable (PV), total, grand total, maximum (peak) value, minimum (valley) value, the value for any of the eight relay set points, manual setting control, or Modbus input. While the output is nominally 4-20 mA, the signal will accurately accommodate under- and over-ranges from 1 to 23 mA.

manual o utput Control

Take control of any output with this feature. All relays can be forced ON or OFF, and the 4-20 mA output signal can be set to any value within its range. When the relays and 4-20 mA output are controlled manually, an LED labeled "M" is turned on and the associated Alarm LEDs (1-8) flash every 10 seconds indicating that the meter is in manual control mode.



Isolated Transmitter Power supplies

A powerful 24 V @ 200 mA power supply is a standard feature on the PROVU meter. It can be configured for 5, 10, or 24 V (default) by means of a simple internal jumper (see manual). An additional power supply (24 V @ 40 mA) is standard with the 4-20 mA output option.

sampling Function (PV Triggered Timed Relay)

The sampling function allows the operator to set a set point for a "sampling" relay. When the process (rate or total) reaches that set point, it will close that relay's contacts for a preset period of time (0.1 to 5999.9 seconds). An example of its use may be for wastewater sampling. When the wastewater total reaches a preset total interval (i.e. every 10,000 gallons), the relay contacts would close for a preset time, and by some means (light, horn, etc.) alert someone to take a sample, or provide the trigger to automatically take a sample of the wastewater (see chart on page 5). The utility of this function can, of course, be expanded beyond sampling and be used whenever a timed relay output closure is required when the rate or a total interval reaches a certain set point.

Interlock Relay(s)

This function allows a process to use one or more very low voltage input signals or simple switch contacts to control the state of one or more internal "interlock" relays. A violation (i.e. loss of input, open switch, or open circuit) forces one or more N/O interlock relay contacts to open. One input can be used in series with a number of interlock switches, or up to eight inputs can be required to force-on one (or more) internal interlock relays. Please see Application Note AN-1008 on our website for more information. Requires PDA1044 Digital I/O module or use of on-board digital input F4.

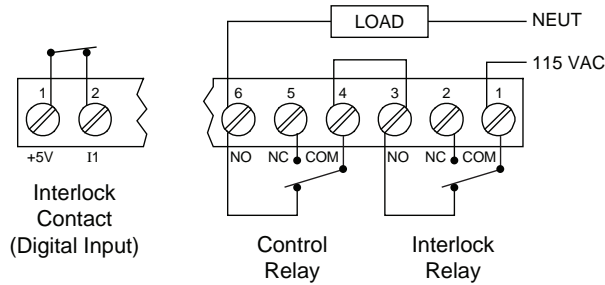

a PPLICa Tions

Differential Pressure Flow

The PD6200 can display flow rate and total by extracting the square root from the 4-20 mA signal from a differential pressure transmitter. The user selectable low-flow cutoff feature gives a reading of zero when the flow rate drops below a user selectable value.

- Display Flow Rate
- User Selectable Low-Flow Cutoff
- Only 2 Calibration Points Required

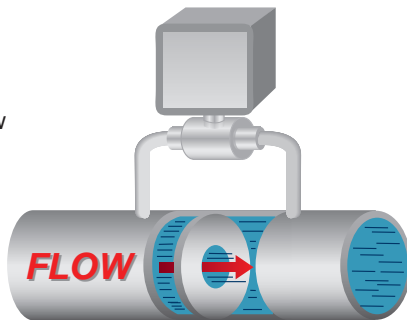

Convert Pulse to 4-20 ma with PD6300

The PD6300 accepts the pulse output from a flowmeter and with the appropriate option installed can convert the pulse to a 4-20 mA signal. The 4-20 mA signal can be programmed to correspond to either the flow rate or the total flow.



- Use K-Factor or Multi-Point Scaling
- ProVu Powers the Flowmeter
- Display Flow Rate & Total

open Channel Flow

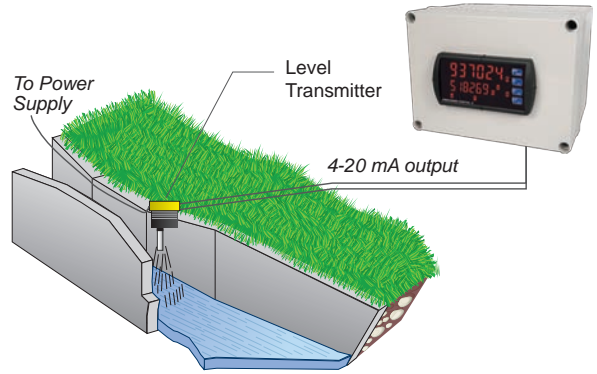

The PD6200, in combination with an ultrasonic level transmitter, makes for an economical way to measure and display open channel flow rate and total in most weirs and flumes and take periodic samples. All the user needs to do is enter the exponent for the weir or flume into the PD6200 and the PD6200 automatically raises the input signal to that power. Sampling can be based on the total flow or the flow rate. For instance, to display open channel flow rate and total from a 3 inch Parshall flume and take a one pint sample every 100,000 gallons, the user would program the PD6200 as follows:

Function	Desire	Programming
Open Channel Flow	3" Parshall flume	Set Programmable Exponent to 1.547
Flow Rate	Millions of Gallons per Day (MGD)	Set 4 mA = 0 & 20 mA = 3.508 Time base = Day
Total	Millions of Gallons	Set Totalizer Conversion Factor = 1 (password protect total reset)
Non-Resettable Grand Total	Program meter so grand total can never be reset	Set non-resettable grand total password
Display	Display Flow Rate and Total at the same time	Set upper display for Grand Total and lower display to toggle between rate and total.
Sampling	Take a 1 pint sample every 100,000 gallons	Set up relay for sampling and to trip every 0.1 million gallons. Set up sampling time such that 1 pint is sampled.

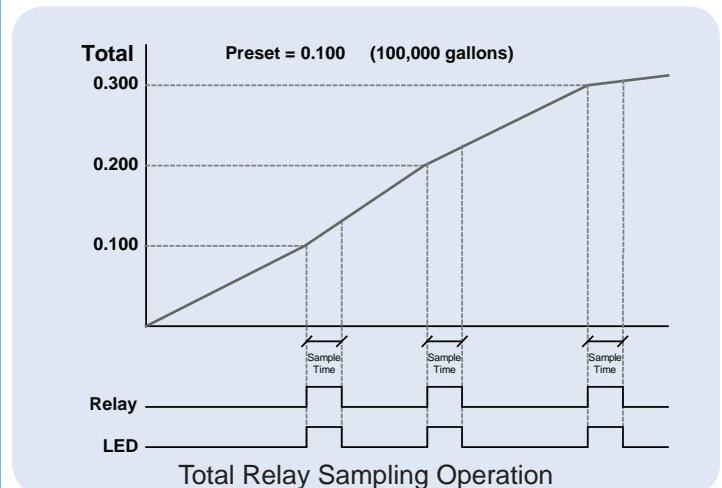

nEma 4 & 4X FIELD EnCLos UREs

Precision Digital offers a variety of rugged enclosures that provide a high degree of protection against harsh operating environments. Thermoplastic and stainless steel NEMA 4X, and painted steel NEMA 4 enclosures for up to 10 ProVu meters are available. See our complete offering at www.predig.com/esu

PRo TEX-maX EXPLos Ion-P Roo F

All the proven features of the ProVu brought into your hazardous areas! Go to www.predig.com/pd8

Conn ECTIONS

PD6200

- Form C (SPDT) relays
- Two isolated power supplies available even on 12/24 VDC input power models
- Removable terminal blocks
- 2 or 4 relays + isolated 4-20 mA output option

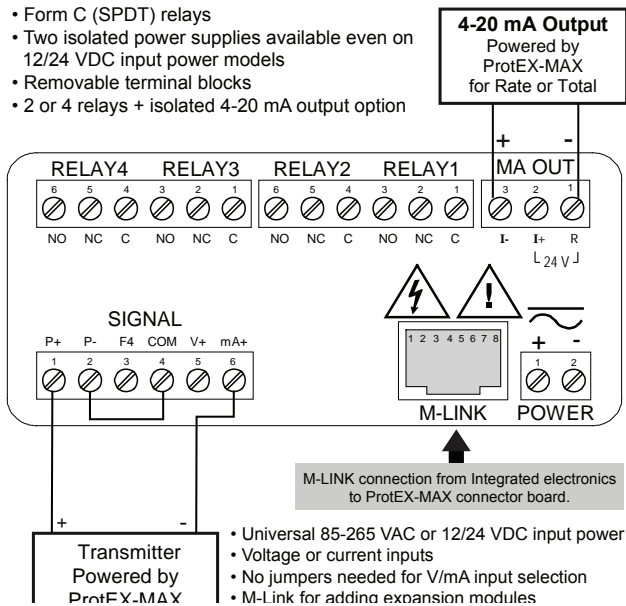

PD6300

- Form C (SPDT) relays
- Two isolated power supplies available even on 12/24 VDC input power models
- Removable terminal blocks
- 2 or 4 relays + isolated 4-20 mA output option

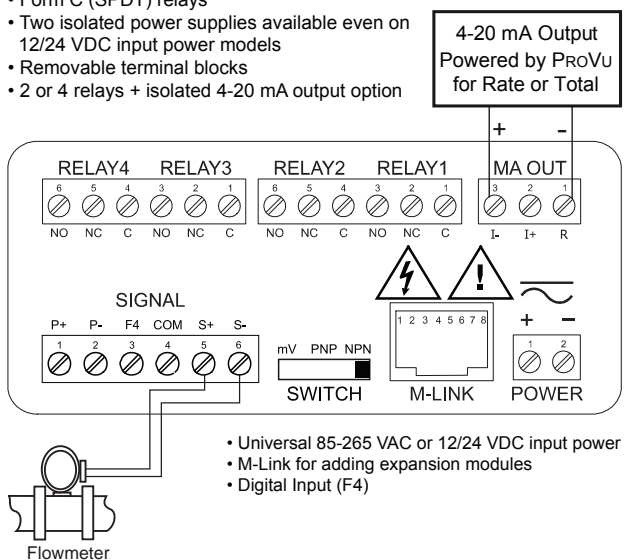

sPECIFICa Tions

Except where noted all specifications apply to operation at +25°C.

General

Display: Upper display: 0.60" (15 mm) high. Lower display: 0.46" (12 mm) high. Both are 6 digits (-99999 to 999999), red LEDs.

Display Intensity: Eight user selectable intensity levels

Display Update Rate: 5/second (200 ms)

o v e r r a n g e: Display flashes 999999

U n d e r r a n g e: Display flashes -99999

Display assignment: The upper and lower displays may be assigned to rate, total, grand total, alternate (rate/total, rate/grand total, rate/units, total/units, and grand total/units), max/min, units (lower display only), set points, or Modbus input. Additional displays are available if parameter total is off, and parameter d-SCAL is on: gross, alternating gross/net, PV1, PV2, and PCT (refer to PD6000 instruction manual).

Front Panel: NEMA 4X, IP65

Programming methods: Four front panel buttons, digital inputs, PC and MeterView Pro software, Modbus registers, or cloning using Copy function.

F4 Digital Input Contacts: 3.3 VDC on contact. Connect normally open contacts across F4 to COM.

F4 Digital Input Logic Levels: Logic High: 3 to 5 VDC
Logic Low: 0 to 1.25 VDC

n o i s e F i l t e r: Programmable from 2 to 199 (0 will disable filter)

Filter Bypass: Programmable from 0.1 to 99.9% of calibrated span

Recalibration: All ranges are calibrated at the factory. Recalibration is recommended at least every 12 months.

max/min Display: Max (Peak) / min (Valley) readings reached by the process are stored until reset by the user or until power to the meter is cycled.

Password: Three programmable passwords restrict modification of programmed settings and two prevent resetting the totals.

n o n - V o l a t i l e m e m o r y: All programmed settings are stored in non-volatile memory for a minimum of ten years if power is lost.

Power options: 85-265 VAC 50/60 Hz, 90-265 VDC, 20 W max, or optional model with 12-24 VDC ±10%, 15 W max.

Fuse: Required external fuse: UL Recognized, 5 A max, slow blow; up to 6 meters may share one 5 A fuse.

Isolated Transmitter Power supply: Terminals P+ & P-: 24 VDC ± 10%. Internally selectable jumper for 24, 10, or 5 VDC supply.

85-265 VAC models rated @ 200 mA max, 12-24 VDC powered models rated @ 100 mA max, @ 50 mA max for 5 or 10 VDC supply.

n o r m a l R e j e c t i o n m o d e: Greater than 60 dB at 50/60 Hz

I s o l a t i o n: 4 kV input/output-to-power line. 500 V input-to-output or output-to-P+ supply.

o v e r v o l t a g e C a t e g o r y: Installation Overvoltage Category II: Local level with smaller transient overvoltages than Installation Overvoltage Category III.

E n v i r o n m e n t a l: Operating temperature range: -40 to 65°C

Storage temperature range: -40 to 85°C

Relative humidity: 0 to 90% non-condensing

C o n n e c t i o n s: Removable screw terminal blocks accept 12 to 22 AWG wire, RJ45 for external relays, digital I/O, and serial communication adapters.

E n c l o s u r e: 1/8 DIN, high impact plastic, UL 94V-0, color: black

m o u n t i n g: 1/8 DIN panel cutout required: 3.622" x 1.772" (92 mm x 45 mm). Two panel mounting bracket assemblies are provided.

T i g h t e n i n g T o r q u e: Screw terminal connectors: 5 lb-in (0.56 Nm)

D i m e n s i o n s: 4.68" x 2.45" x 5.64" (119 mm x 62 mm x 143 mm) (W x H x D)
w e i g h t: 9.5 oz (269 g)

U L F i l e n u m b e r: UL & c-UL Listed. E160849; 508 Industrial Control Equipment.

w a r r a n t y: 3 years parts & labor

U s B C o n n e c t i o n: Compatibility: USB 2.0 Standard, Compliant
Connector Type: Micro-B receptacle

Cable: USB A Male to Micro-B Cable

Driver: Windows 98/SE, ME, 2000, Server 2003/2008, XP 32/64-Bit, Vista 32/64-Bit, Windows 7 32/64-Bit, Windows 10 32/64-Bit

Power: USB Port

PD6200 analog Inputs

Inputs: Field selectable: 0-20, 4-20 mA, ±10 VDC (0-5, 1-5, 0-10 V), Modbus PV (Slave)

accuracy: ±0.03% of calibrated span ±1 count, square root & programmable exponent accuracy range: 10-100% of calibrated span

Temperature Drift: 0.005% of calibrated span/°C max from 0 to 65°C ambient, 0.01% of calibrated span/°C max from -40 to 0°C ambient

signal Input Conditioning: Linear, square root, programmable exponent, or round horizontal tank volume calculation.

multi-Point Linearization: 2 to 32 points

Programmable Exponent: 1.0001 to 2.9999

Low-Flow Cutoff: 0-999999 (0 disables cutoff function)

Decimal Point: Up to five decimal places or none: dddddd, dddddd, dddddd, dddddd, or dddddd.

Calibration Range:

Input Range	Minimum Span Input 1 & 2
4-20 mA	0.15 mA
±10 V	0.10 V

An Error message will appear if input 1 and input 2 signals are too close together.

Input Impedance: Voltage ranges: greater than 1 MΩ.

Current ranges: 50 - 100 Ω (depending on resettable fuse impedance).

Input overload: Current input protected by resettable fuse, 30 VDC max. Fuse resets automatically after fault is removed.

PD6300 Rate Inputs

Inputs: Field selectable: Pulse or square wave 0-5 V, 0-12 V, or 0-24 V @ 30 kHz; TTL; open collector 4.7 kΩ pull-up to 5 V @ 30 kHz; NPN or PNP transistor, switch contact 4.7 kΩ pull-up to 5 V @ 40 Hz; coil (sine wave) 40 mVp-p min @ 10 kHz; Modbus PV (Slave)

Low Voltage mag Pickup (Isolated): Sensitivity: 40 mVp-p to 8 Vp-p

minimum Input Frequency: 0.001 Hz - Minimum frequency is dependent on high gate setting.

maximum Input Frequency: 30,000 Hz (10,000 for Low Voltage Mag Pickup)

Input Impedance: Pulse input: Greater than 300 kΩ @ 1 kHz. Open collector/switch input: 4.7 kΩ pull-up to 5 V.

accuracy: ±0.03% of calibrated span ±1 count

Display Update Rate: Total: 10/sec, Rate: 10/sec to 1/1000 sec

Temperature Drift: Rate display is not affected by changes in temperature.

multi-Point Linearization: 2 to 32 points

Low-Flow Cutoff: 0-999999 (0 disables cutoff function)

Decimal Point: Up to five decimal places or none: dddddd, dddddd, dddddd, dddddd, or dddddd.

Calibration: May be calibrated using K-factor, scale using internal calibration, or calibrate by applying an external calibration signal.

K-Factor: Field programmable K-factor converts input pulses to rate in engineering units. May be programmed from 0.00001 to 999,999 pulses/unit.

Calibration Range: Input 1 signal may be set anywhere in the range of the meter; input 2 signal may be set anywhere above setting.

Filter: Programmable contact de-bounce filter, 40 to 999 Hz maximum input frequency allowed with low speed filter.

Time Base: Second, minute, hour, or day

Low Gate: 0.1-99.9 seconds

High Gate: 2.0-999.9 seconds

Rate/Totalizer

Rate Display Indication: 0 to 999999, lead zero blanking. "R" LED illuminates while displaying rate.

Total Display & Total overflow: 0 to 999,999; automatic lead zero blanking. "T" LED is illuminated while displaying total and "GT" for grand total. Up to 999,999,999 with total-overflow feature. "oF" is displayed to the left of total overflow and ▲ LED is illuminated.

Total Decimal Point: Up to five decimal places or none: dddddd, dddddd, dddddd, dddddd, or dddddd.

Total decimal point is independent of rate decimal point.

Totalizer: Calculates total based on rate and field programmable multiplier to display total in engineering units. Time base must be selected according to the time units in which the rate is displayed. Selectable up/down count.

Total Conversion Factor: 0.00001 to 59,999

Totalizer Rollover: Totalizer rolls over when display exceeds 999,999,999. Relay status reflects the display value.

Total overflow override: Program total reset for automatic with 0.1 second delay and set point 1 for 999,999

Totalizer Presets: Up to eight, user selectable under Setup menu. Any set point can be assigned to total and may be programmed anywhere in the range of the meter for total alarm indication.

Programmable Total Reset Delay: 0.1 to 999.9 seconds; applied to the first relay assigned to total or grand total. If the meter is programmed to reset total to zero automatically when the preset is reached, then a delay will occur before the total is reset.

Total Reset: Via front panel button, external contact closure on digital inputs, automatically via user selectable preset value and time delay, or through serial communications.

Total Reset Password: Total and grand total passwords may be entered to prevent resetting the total or grand total from the front panel.

non-Resettable Total: The grand total can be programmed as a non-resettable total by entering the password "050873".

Caution: Once the Grand Total has been programmed as "non-resettable" the feature cannot be disabled.

Relays

Rating: 2 or 4 SPDT (Form C) internal and/or 4 SPST (Form A) external; rated 3 A @ 30 VDC and 125/250 VAC resistive load; 1/14 HP (≈ 50 W) @ 125/250 VAC for inductive loads

noise suppression: Noise suppression is recommended for each relay contact switching inductive loads.

Relay assignment: Relays may be assigned to rate, total, or grand total.

Deadband: 0-100% of span, user programmable

High or Low alarm: User may program any alarm for high or low trip point. Unused alarm LEDs and relays may be disabled (turned off).

Relay operation: automatic (non-latching), latching (requires manual acknowledge), sampling (based on time), pump alternation control (2 to 8 relays), off (disable unused relays), and manual on/off control mode.

Relay Reset: User selectable via front panel buttons, digital inputs, or PC

1. Automatic reset only (non-latching), when input passes the reset point or total is reset to zero.

2. Automatic + manual reset at any time (non-latching).

3. Manual reset only, at any time (latching).

4. Manual reset only after alarm condition has cleared (latching).

Note: Front panel button or digital input may be assigned to acknowledge relays programmed for manual reset.

Deadband: 0-100% of span, user programmable

Time Delay: 0 to 999.9 seconds, on & off relay time delays. Programmable and independent for each relay.

Fail-safe operation: Programmable and independent for each relay.

Note: Relay coil is energized in non-alarm condition. In case of power failure, relay will go to alarm state.

auto Initialization: When power is applied to the meter, relays will reflect the state of the input to the meter.

PD6200 / PD6300 ProVu® Flow Rate/Totalizers

Isolated 4-20 ma Transmitter output

output source: Rate/process, total, grand total, max, min, set points 1-8, manual control setting, or Modbus input

scaling Range: 1.000 to 23.000 mA for any display range

Calibration: Factory calibrated: 4.000 to 20.000 = 4-20 mA output

analog output Programming: 23.000 mA maximum for all parameters: Overrange, underrange, max, min, and break

accuracy: $\pm 0.1\%$ FS ± 0.004 mA

Temperature Drift: 0.4 μ A/°C max from 0 to 65°C ambient,

0.8 μ A/°C max from -40 to 0°C ambient

Note: Analog output drift is separate from input drift.

Isolated Transmitter Power supply: Terminals I+ & R: 24 VDC $\pm 10\%$.

Isolated from the input at >500 V. May be used to power the 4-20 mA output or other devices. All models rated @ 40 mA max.

External Loop Power supply: 35 VDC maximum

output Loop Resistance:

Power supply	Minimum	Maximum
24 VDC	10 Ω	700 Ω
35 VDC (external)	100 Ω	1200 Ω

serial Communications

Protocol: Modbus® RTU

meter address/slave ID: 1 - 247

Baud Rate: 300 - 19,200 bps

Transmit Time Delay: Programmable between 0 and 199 ms or transmitter always on for RS-422 communication

Data: 8 bit (1 start bit, 1 or 2 stop bits)

Parity: Even, odd, or none with 1 or 2 stop bits

Byte-to-Byte Timeout: 0.01 - 2.54 seconds

Turn a round Delay: Less than 2 ms (fixed)

Note: Refer to the ProVu® Modbus Register Tables located at www.predig.com for details.

Digital I/o Expansion module

Channels: 4 digital inputs & 4 digital outputs per module

system: Up to 2 modules for a total of 8 inputs & 8 outputs

Digital Input Logic: High: 3 to 5 VDC Low: 0 to 1.25 VDC

Digital output Logic: High: 3.1 to 3.3 VDC Low: 0 to 0.4 VDC

source Current: 10 mA maximum

sink Current: 1.5 mA minimum

+5 V Terminal: To be used as pull-up for digital inputs only.

4-Relay Expansion module

Relays: Four Form A (SPST) rated 3 A @ 30 VDC and 125/250 VAC resistive load; 1/14 HP (≈ 50 watts) @ 125/250 VAC for inductive loads.

Dimensions

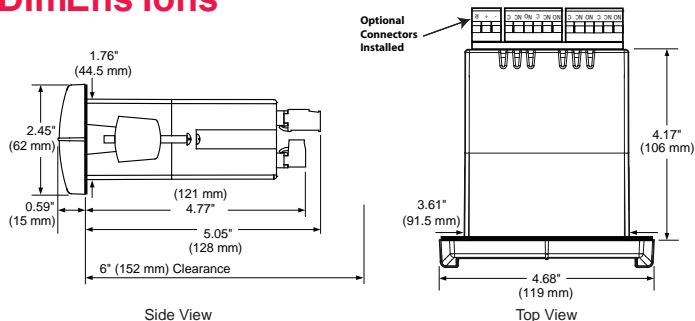

Notes:

1. Panel cutout required: 1.772" x 3.622" (45mm x 92mm)
2. Panel thickness: 0.040 - 0.250" (1.0mm - 6.4mm)
3. Mounting brackets lock in place for easy mounting
4. Clearance: Allow 6" (152 mm) behind the panel

Ordering Information

ProVu® PD6200 analog Inputs		
85-265 Va C model	12-24 VDC model	options Installed
PD6200-6R0	PD6200-7R0	None
PD6200-6R2	PD6200-7R2	2 Relays
PD6200-6R3	PD6200-7R3	4-20 mA Output
PD6200-6R4	PD6200-7R4	4 Relays
PD6200-6R5	PD6200-7R5	2 Relays & 4-20 mA Output
PD6200-6R7	PD6200-7R7	4 Relays & 4-20 mA Output

To order SunBright display models replace the "R" with "H" (i.e. PD6200-6H2)
Note: 24 V flowmeter power supply standard on all models.

ProVu® PD6300 Pulse Inputs		
85-265 Va C model	12-24 VDC model	options Installed
PD6300-6R0	PD6300-7R0	None
PD6300-6R2	PD6300-7R2	2 Relays
PD6300-6R3	PD6300-7R3	4-20 mA Output
PD6300-6R4	PD6300-7R4	4 Relays
PD6300-6R5	PD6300-7R5	2 Relays & 4-20 mA Output
PD6300-6R7	PD6300-7R7	4 Relays & 4-20 mA Output

To order SunBright display models replace the "R" with "H" (i.e. PD6300-6H2)
Note: 24 V flowmeter power supply standard on all models.

Accessories	
model	Description
PDA1002	DIN Rail Mounting Kit for Two Expansion Modules
PDA1004	4-Relay Expansion Module
PDA1044	4 Digital Inputs & 4 Digital Outputs Module
PDA1232	RS-232 Serial Adapter
PDA1485	RS-485 Serial Adapter
PDA7485-I	RS-232 to RS-422/485 Isolated Converter
PDA7485-N	RS-232 to RS-422/485 Non-Isolated Converter
PDA8232-N	USB to RS-232 Non-Isolated Converter
PDA8485-I	USB to RS-422/485 Isolated Converter
PDA8485-N	USB to RS-422/485 Non-Isolated Converter
PDX6901	Suppressor (snubber): 0.01 μ F/470 Ω , 250 VAC

your Local Distributor is:

Order from:

C A Briggs Company

622 Mary Street; Suite 101

Warminster, PA 18974

Phone: 267-673-8117 - Fax: 267-673-8118

Sales@cabriggs.com - www.cabriggs.com

Disclaimer

The information contained in this document is subject to change without notice. Precision Digital Corporation makes no representations or warranties with respect to the contents hereof, and specifically disclaims any implied warranties of merchantability or fitness for a particular purpose. ©2010-2016 Precision Digital Corporation. All rights reserved.

LDS6200_E 05/16

PRECISION DIGITAL CORPORATION

233 South Street • Hopkinton MA 01748 USA • Tel (800) 343-1001 • Fax (508) 655-8990



www.predig.com