

SIMPLEX

INSTRUCTION MANUAL



MOTOR PROTECTION ELECTRONICS, INC.

2464 Vulcan Road
Apopka, Florida 32703

Phone: (407) 299-3825
Website: www.mpeelectronics.com

Operating Program Revision: 2

Revision Date: 2-11-15

Order from: **C A Briggs Company**; 622 Mary Street; Suite 101 - Warminster, PA 18974
Phone: 267-673-8117 - 800-352-6265 - Fax: 267-673-8118; E-Mail: Sales@cabriggs.com - www.cabriggs.com

SIMPLEXER

APPLICATIONS

- Simplex Pumping Stations that Control Liquid Level
- Pump Down (Empty a Tank)
- Where Connection to a SCADA System is Required

STANDARD FEATURES

- Float or Conductance Probe Level Inputs
- Level Input Status Indication
- Pump Call to Run Indication
- High Alarm Indication
- Level Simulation / Alarm Silence Push-Button
- H-O-A (Hand-Off-Auto) toggle switch
- Pump Run, Alarm Light, and Alarm Horn Relays
- Surge Protected Level Inputs
- 10 second Power Up Delay
- RS232 Serial Port with Modbus RTU Protocol
- Setup and Troubleshooting Features Available using a Separately Supplied Touch Screen Interface Device



SPECIFICATIONS

Input Power:	120VAC \pm 10%, 10VA max
Relay Outputs:	6A Resistive @ 120VAC 3.6A Inductive @ 120VAC
Agency Approval:	UL 508, CAN/CSA UL FILE #: E101681
Operating Temp:	-20 °C to +60 °C
Storage Temp:	-45 °C to +85 °C
Indicators:	LED
Sensor Output Voltage:	\pm 12V Square wave
Sensor Output Current:	\pm 1.2mA max (per sensor)
Color:	White with Blue Lettering
Enclosure Material:	Lexan

ORDERING INFORMATION

Part Number: 010 - 120 - 121 P

TOUCH SCREEN INTERFACE DEVICE

The Touch Screen Interface Device (TSID) is an optional piece of equipment that is used to perform troubleshooting and customization of the Simplexer for specific applications. It provides full access to all the setup and diagnostic parameters. It also has a screen designed to demo the SCADA capabilities of the Simplexer.

TSID FUNCTIONS

- Setup Simplexer for use in SCADA System
- View Status of Float Switch / Level Probe Inputs
- View Level Input Out of Sequence Data
- Setup of the Level Input Sensitivity
- View and Reset Fault Codes
- Demo SCADA features



TSID COMMUNICATION WITH SIMPLEXER

The **Touch Screen Interface Device** communicates with the Simplexer through its RS232 serial port. The serial port setup of both devices must match the following:

Baud Rate = 9600 bps Parity Mode = 0 Stop Bits = 2 Slave Address = 1

To make the Simplexer's serial port settings match the TSID's serial port settings, hold down the push-button on the controller for 22 seconds. (This will also temporarily make the Register Access Mode = 1.)

When all the work using the TSID is done and the TSID is disconnected from the controller, you must wait 5 seconds before connecting the controller to a SCADA system. The 5 seconds of no communication is required to signal the Simplexer that it is time to start using the serial port settings programmed into it for the application.

The Touch Screen Interface Device (TSID) consists of a 6 inch Touch Screen panel made by Automation Direct, housed in a durable carrying case with a power cord and an interface cable for connection to the serial port. It is programmed as a Modbus Master that continually polls the Simplexer.

ORDERING INFORMATION

Part Number: TSID

H-O-A TOGGLE SWITCH

The H-O-A (Hand-Off-Auto) toggle switch provides control over the pump for maintenance or testing purposes. When the H-O-A switch is placed in the “Hand” position the pump will be called to run. When placed in the “Auto” position the pump will be turned on and off as needed to maintain the wet well level, based on the level inputs. Placing the H-O-A in the “Off” position disables the pump from operating.

PUMP RUN INDICATOR

The pump call to RUN indicator is turned on when the pump call-to-run relay is energized, in either “HAND” or “AUTO” mode.

HIGH LEVEL ALARM

Alarm Indication

The “ALARM” indicator is turned on whenever the ALARM input is closed or covered.

Alarm Light Relay

The Alarm Light relay contacts are closed whenever the ALARM input is closed or covered.

Alarm Horn Relay

The Alarm Horn relay contacts are closed when the ALARM input is closed or covered, except when the Alarm Horn has been silenced.

Silencing the Alarm Horn

To silence the Alarm Horn, press the push-button on the front of the unit.

To silence the Alarm Horn remotely through the SCADA system, momentarily set Coil 2 in Register 40001.

POWER UP DELAY

Whenever electrical power is lost and then restored, immediate pump operation is prevented by a fixed ten second “Power Up Delay” which must first expire before a pump is called to run.

LEVEL SIMULATION

Entering the Level Simulation Mode

To enter the Level Simulation mode press and hold the push-button, on the front of the unit, for three seconds or until one or more of the level indicators are turned on.

Increasing the Simulated Level

To increase the simulated level, hold the push-button until the desired level is indicated on the level status indicators. There is a three second delay between levels. With the H-O-A in the “Auto” position, the pump will be called to run as the level is increased to the On level.

Decreasing the Simulated Level

To decrease the simulated level, release the push-button. The level will decrease by one level every three seconds.

Exiting the Level Simulation Mode

To exit the Level Simulation mode, release the push-button and wait until all the level indicators are turned off. Three seconds after the last level indicator is turned off, the unit exits the Level Simulation mode.

ELAPSED TIME METER

The Elapsed Time Meter (ETM) may be read through the SCADA system at Register 40006. The ETM data is stored in non-volatile memory registers at the end of each pump run cycle. The latest addition to the run time may be lost if a power outage occurs while a pump is called to run. To reset the ETM to zero, momentarily set Coil 5 in Register 40001. The ETM register has a range of 0.0 - 6553.5 hours (the decimal point must be inserted by the HMI).

LEVEL INPUTS

The Off, On, and Alarm level inputs allow the controller to determine the level of the liquid in the wet well. The inputs may be connected to either three float switches, a three point conductance probe, three single point conductance probes, or three selected points on a ten point conductance probe.

The controller sends a $\pm 12V$ square wave signal to each of the float switches or probe electrodes and monitors the signals. For applications that use float switches, the common side of all the float switches is connected to ground. In applications that use a conductance probe (Level Probe), the liquid must be grounded. When a float switch is closed or liquid covers one of the probe electrodes, the square wave signal is partially or fully diverted to ground, and the respective input's Level Input Status Value changes from a high number to a lower number. The Level Input Status Value associated with the input is then compared to the Level Input Sensitivity setting. When the input's Level Input Status Value is determined to be below the Level Input Sensitivity setting, the Simplexer's input is considered to be closed or covered.

Float Switch Applications

Where float switches are used, the float switch contacts must be the Normally Open type that close as the liquid level rises to cover or tilt the float switch.

Conductance Probe Applications

For applications that use a conductance probe, the liquid in the wet well must contain a high enough concentration of ions to allow the water to conduct a sufficient amount of electrical current. Sewage contains a lot of ions and is a very good conductor of electricity. However, clean water has a low number of ions, which can be difficult to detect. Using a conductance probe in a storm water application is not recommended. While storm water may start out with enough ions to detect, it becomes more difficult to detect the longer it rains, as the run off becomes cleaner (rainwater is naturally distilled, containing relatively few ions).

Grounding The Liquid

When used with a conductance probe, the liquid in the wet well must have an electrical connection to the control panel ground. Where a submersible pump is present, the grounded housing of the pump is sufficient. In the absence of any other path to ground, a single point probe, or the bottom electrode of a ten point probe, may be placed low in the wet well and connected to the control panel ground.

Level Input Sensitivity

The **Level Input Sensitivity** may be changed using the **Touch Screen Interface Device**.

Parameter	Register Address	Default Value	Recommended Setting	
Level Input Sensitivity	40018	100	Float Switch	100
			Typical Sewage (Conductance Probe)	100
			Light Sewage (Conductance Probe)	150

When using a Conductance Probe, the best setting for your application may be determined by performing the following procedure:

1. Ensure that the "Off" electrode is covered with liquid.
2. Use the **TSID** to read the Level Input Status Value for the "Off" level input.
3. Add about 40 to the Level Input Status Value of the covered input. (For example typical sewage will produce a value of around 60 or less. When you add 40 to that value, you have a recommended setting of 100, which is the default setting for typical sewage.)

OUT OF SEQUENCE - Pump Operation

The Simplexer's pump control logic detects the following out-of-sequence conditions and provides the following modified pump operation:

Out-Of-Sequence Condition	Pump Operation
OFF INPUT - Out-Of-Sequence On and Alarm Inputs Close Before the Off .	Turns on pump when the On and Alarm inputs close.
ON INPUT - Out-Of-Sequence Off and Alarm Inputs Close Before the On .	Turns on pump when the Off and Alarm inputs close.
ALARM INPUT - Out-Of-Sequence Alarm Input fails to Open Before Off and On Inputs Open. (Alarm Input Always Closed.)	Turns on pump when either the Off or On inputs close.

OUT OF SEQUENCE - Trouble Shooting

By using the **Touch Screen Interface Device** an operator may view which input the controller determined to be out-of-sequence. However, if the power had been cycled since the event, the data is lost.

Currently Out Of Sequence - When inputs are currently out-of-sequence, the "Currently Out-Of-Sequence" data may be viewed using the Touch Screen Interface Device from SCADA register 40005, Coils 65, 66, and 68.

Latched Out Of Sequence - When an input is out-of-sequence the data is copied and latched so that later an operator may view which inputs were previously out-of-sequence. The data is labeled "Latched Out-Of-Sequence" and may be viewed using the Touch Screen Interface Device which reads the data from SCADA register 40005, Coils 69, 70, and 72.

Whenever there is an input with a "Latched Out-Of-Sequence" condition a "Fault Code" of 21 will also be present in the "Fault Code" SCADA register 40004.

The "Latched Out-Of-Sequence" data may be erased by cycling the power or by pressing the "Fault Reset" button on the Touch Screen Interface Device, which toggles the "Fault Code - Reset" SCADA register 40001, Coil 8.

FAULT CODES

When the controller detects a fault condition, a Fault Code is generated and placed into Register 40004. The **Fault Code** may be viewed using the **Touch Screen Interface Device**. See the Fault Code Table below for a description of the condition.

Fault Code Table

Fault Code	Description of Condition
0	Normal
1	Communication Fault – Overrun Error reading incoming message.
2	Communication Fault – Time out error reading incoming message.
3	Communication Fault – Time out error responding to message.
4	Communication Fault – Incoming message failed Checksum Test.
5	Communication Fault – Invalid Modbus Function Code.
6	Communication Fault – Trying to preset more than 35 registers using Function Code No. 16.
7	Communication Fault – Trying to force to more than 100 Coils using Function Code No. 15.
8	Communication Fault – Write Attempt to Register Not Marked for “Write” using Function Code No. 05.
9	Communication Fault – Write Attempt to Register Not Marked for “Write” using Function Code No. 06.
10	Communication Fault – Write Attempt to Register Not Marked for “Write” using Function Code No. 15.
11	Communication Fault – Write Attempt to Register Not Marked for “Write” using Function Code No. 16.
12	Communication Fault – Write Attempt made with Register Access Mode Parameter set for Read Only.
13	Communication Fault – The UART detected a Framing Error reading the incoming message. It did not find Stop Bit where expected.
14	Communication Fault – Noise Detected on incoming message.
21	Level Input Out-Of-Sequence.

REMOTE PUMP CONTROL

Disable Pumps

The pumps may be disabled through the SCADA system by setting Coil 1 in register 40001.
To return a pump to normal control clear Coil 1 in register 40001.

Force On Pumps

The pumps may be forced on through the SCADA system by setting Coil 3 in register 40001.
To return a pump to normal control clear Coil 3 in register 40001.

Remote Control Command Cancel Delay

If communication is lost while the pumps are being controlled remotely, the remote control commands will be automatically canceled upon the expiration of the Remote Control Command Cancel Delay. Momentarily turning off the electrical power to the controller will also cancel the remote control commands.

The **Remote Control Command Cancel Delay** may be changed using the **Touch Screen Interface Device**.

Parameter	Register Address	Default Value	Setting Definitions
Remote Control Command Cancel Delay	40027	1 Minute	Delay Range: 1 - 254 Minutes To Prevent Remote Control Commands From Being Canceled - Set On: 255

SETUP FOR CONNECTION TO A SCADA SYSTEM

Slave Address

Each controller in a SCADA system using the Modbus protocol is assigned a unique Slave Address so that it can be polled by the SCADA system Master using that unique Slave Address.

The Slave Address parameter may be setup using the **Touch Screen Interface Device**:

Parameter	Register Address	Default Value	Setting Definitions
Slave Address	40022	1	Range: 1 - 247

Register Access Mode

The Register Access Mode parameter is provided to prevent (when set on Read Only) malicious attempts to remotely control the pumps, or change setup parameter values. Unless greatly needed, the Register Access Mode should be left on Read & Write.

The Register Access Mode parameter may be setup using the **Touch Screen Interface Device**:

Parameter	Register Address	Default Value	Setting Definitions
Register Access Mode	40020	1	1 = Read & Write 2 = Read Only

NOTE: If the Register Access Mode is changed to "Read Only" the Simplexer will not allow any other changes to the parameter values. However, when connected to the **Touch Screen Interface Device**, the controller can be temporarily placed into the "Read & Write" mode by holding down the push-button on the controller for 22 seconds. It will automatically return to the "Read Only" mode, 5 seconds after being disconnected from the Touch Screen Interface Device.

Setup of RS232 Serial Port

The controller's RS232 serial port must be setup to communicate with the device it is connected to. The Baud Rate, Parity Mode and Stop Bits parameter values of the two devices must be set to match.

The Delay Before Response parameter is provided for cases where the modem needs additional time to prepare itself before receiving a response back from the controller.

The following parameters may be setup using the **Touch Screen Interface Device**:

Parameter	Register Address	Default Value	Setting Definitions
Baud Rate	40023	4	1 = 1200 bps 2 = 2400 bps 3 = 4800 bps 4 = 9600 bps
Parity Mode	40024	0	0 = No Parity 1 = Odd Parity 2 = Even Parity
Stop Bits	40025	2	1 = 1 Stop Bit 2 = 2 Stop Bits (The 2 nd Stop Bit is available only when No Parity is selected)
Delay Before Response	40026	3 ms	Range: 1 – 100 ms

MODBUS Functions Supported

Function Code	Function Description	Notes
01	Read Coil Status	
02	Read Input Status	
03	Read Holding Registers	
04	Read Input Registers	
05	Force Single Coil	
06	Preset Single Register	
08	Diagnostics - Sub-function 00 (Return Query Data)	
15	Force Multiple Coils	Limited to 100 Coils
16	Preset Multiple Registers	Limited to 35 Registers

SCADA REGISTERS

Register Address	Read	Write	Description of SCADA Registers																																																			
40001	√	√	<table border="1"> <thead> <tr> <th>16</th><th>15</th><th>14</th><th>13</th><th>12</th><th>11</th><th>10</th><th>9</th><th>8</th><th>7</th><th>6</th><th>5</th><th>4</th><th>3</th><th>2</th><th>1</th> <th>Coil</th> </tr> </thead> <tbody> <tr> <td></td><td></td><td></td><td></td><td></td><td></td><td></td><td></td><td>Fault Code - Reset</td><td></td><td></td><td>ETM - Reset</td><td></td><td>Pump - Force On</td><td>Alarm Horn - Silence</td><td>Pump - Disable</td> <td></td> </tr> <tr> <th>15</th><th>14</th><th>13</th><th>12</th><th>11</th><th>10</th><th>9</th><th>8</th><th>7</th><th>6</th><th>5</th><th>4</th><th>3</th><th>2</th><th>1</th><th>0</th> <th>Bit</th> </tr> </tbody> </table>	16	15	14	13	12	11	10	9	8	7	6	5	4	3	2	1	Coil									Fault Code - Reset			ETM - Reset		Pump - Force On	Alarm Horn - Silence	Pump - Disable		15	14	13	12	11	10	9	8	7	6	5	4	3	2	1	0	Bit
16	15	14	13	12	11	10	9	8	7	6	5	4	3	2	1	Coil																																						
								Fault Code - Reset			ETM - Reset		Pump - Force On	Alarm Horn - Silence	Pump - Disable																																							
15	14	13	12	11	10	9	8	7	6	5	4	3	2	1	0	Bit																																						
40002	√		<table border="1"> <thead> <tr> <th>32</th><th>31</th><th>30</th><th>29</th><th>28</th><th>27</th><th>26</th><th>25</th><th>24</th><th>23</th><th>22</th><th>21</th><th>20</th><th>19</th><th>18</th><th>17</th> <th>Coil</th> </tr> </thead> <tbody> <tr> <td></td><td></td><td></td><td></td><td></td><td></td><td></td><td></td><td></td><td>Alarm Light - Status</td><td>Alarm Horn - Status</td><td>Pump Run - Status</td><td>Alarm Level Input - Status</td><td></td><td>On Level Input - Status</td><td>Off Level Input - Status</td> <td></td> </tr> <tr> <th>15</th><th>14</th><th>13</th><th>12</th><th>11</th><th>10</th><th>9</th><th>8</th><th>7</th><th>6</th><th>5</th><th>4</th><th>3</th><th>2</th><th>1</th><th>0</th> <th>Bit</th> </tr> </tbody> </table>	32	31	30	29	28	27	26	25	24	23	22	21	20	19	18	17	Coil										Alarm Light - Status	Alarm Horn - Status	Pump Run - Status	Alarm Level Input - Status		On Level Input - Status	Off Level Input - Status		15	14	13	12	11	10	9	8	7	6	5	4	3	2	1	0	Bit
32	31	30	29	28	27	26	25	24	23	22	21	20	19	18	17	Coil																																						
									Alarm Light - Status	Alarm Horn - Status	Pump Run - Status	Alarm Level Input - Status		On Level Input - Status	Off Level Input - Status																																							
15	14	13	12	11	10	9	8	7	6	5	4	3	2	1	0	Bit																																						
40004	√		Fault Code																																																			
40005	√		<table border="1"> <thead> <tr> <th>80</th><th>79</th><th>78</th><th>77</th><th>76</th><th>75</th><th>74</th><th>73</th><th>72</th><th>71</th><th>70</th><th>69</th><th>68</th><th>67</th><th>66</th><th>65</th> <th>Coil</th> </tr> </thead> <tbody> <tr> <td></td><td></td><td></td><td></td><td></td><td></td><td></td><td></td><td>Alarm Level Input Latched Out-Of-Sequence</td><td></td><td>On Level Input Latched Out-Of-Sequence</td><td>Off Level Input Latched Out-Of-Sequence</td><td>Alarm Level Input Currently Out-Of-Sequence</td><td></td><td>On Level Input Currently Out-Of-Sequence</td><td>Off Level Input Currently Out-Of-Sequence</td> <td></td> </tr> <tr> <th>15</th><th>14</th><th>13</th><th>12</th><th>11</th><th>10</th><th>9</th><th>8</th><th>7</th><th>6</th><th>5</th><th>4</th><th>3</th><th>2</th><th>1</th><th>0</th> <th>Bit</th> </tr> </tbody> </table>	80	79	78	77	76	75	74	73	72	71	70	69	68	67	66	65	Coil									Alarm Level Input Latched Out-Of-Sequence		On Level Input Latched Out-Of-Sequence	Off Level Input Latched Out-Of-Sequence	Alarm Level Input Currently Out-Of-Sequence		On Level Input Currently Out-Of-Sequence	Off Level Input Currently Out-Of-Sequence		15	14	13	12	11	10	9	8	7	6	5	4	3	2	1	0	Bit
80	79	78	77	76	75	74	73	72	71	70	69	68	67	66	65	Coil																																						
								Alarm Level Input Latched Out-Of-Sequence		On Level Input Latched Out-Of-Sequence	Off Level Input Latched Out-Of-Sequence	Alarm Level Input Currently Out-Of-Sequence		On Level Input Currently Out-Of-Sequence	Off Level Input Currently Out-Of-Sequence																																							
15	14	13	12	11	10	9	8	7	6	5	4	3	2	1	0	Bit																																						
40006	√		Pump Elapsed Time Meter (hours and 1/10 hours) 0.0 - 6553.5 hours																																																			
40042	√		Power Supply Voltage (Volts and 1/10 Volts) Normal Range: 14.4V - 20.4V																																																			

SETUP PARAMETER REGISTERS

Register Address	Read	Write	Description of Setup Parameter Registers
40018	√	√	Level Input Sensitivity
40020	√	√	Serial Port Setup - Register Access Mode
40022	√	√	Serial Port Setup - Slave Address
40023	√	√	Serial Port Setup - Baud Rate
40024	√	√	Serial Port Setup - Parity Mode
40025	√	√	Serial Port Setup - Stop Bits
40026	√	√	Serial Port Setup - Delay Before Response
40027	√	√	Serial Port Setup - Remote Control Command Cancel Delay

CONNECTION DIAGRAMS

Float Switch Input

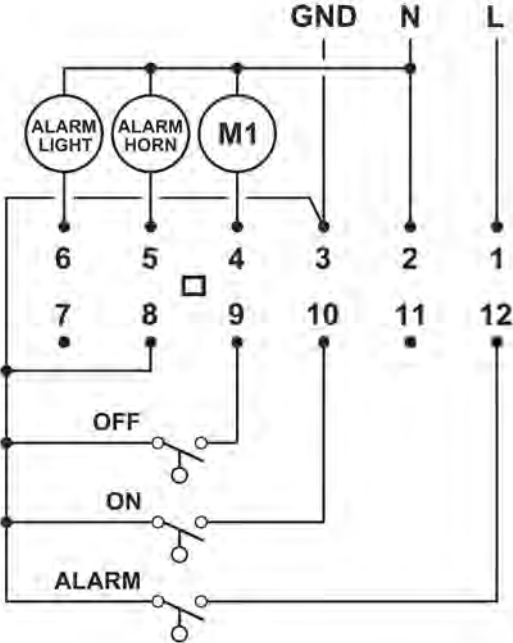

Level Probe Input

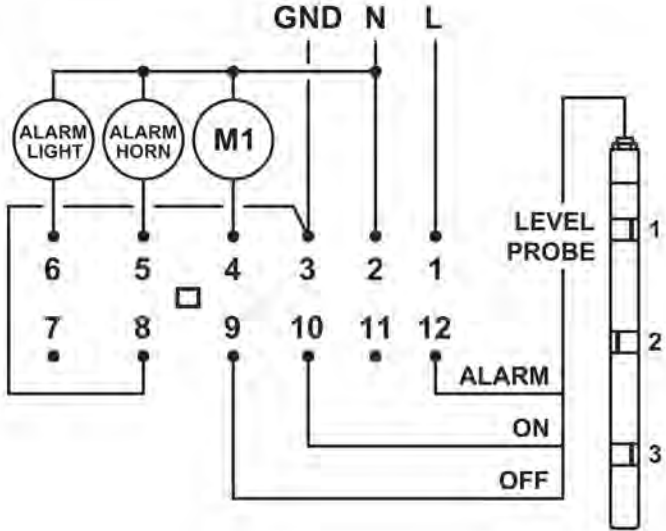

Serial Port

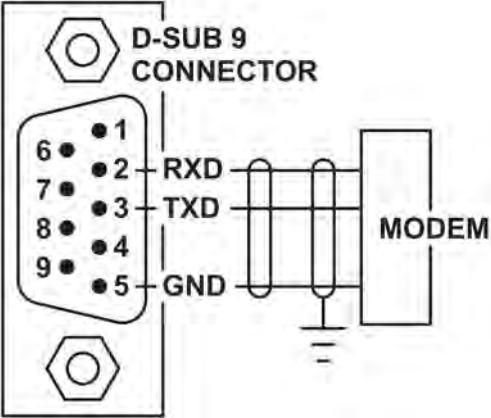

ENCLOSURE MECHANICAL LAYOUT

Front View

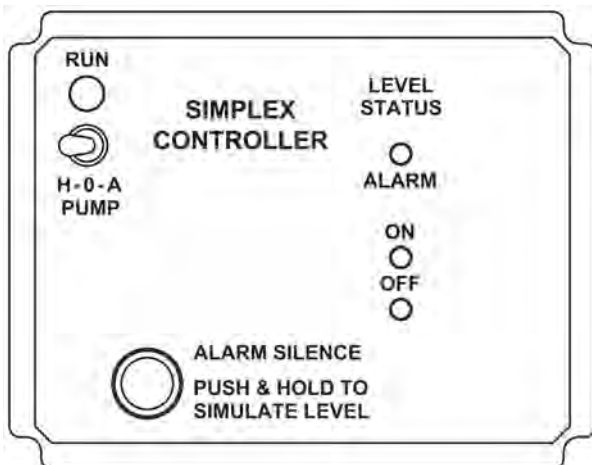

Right Side View

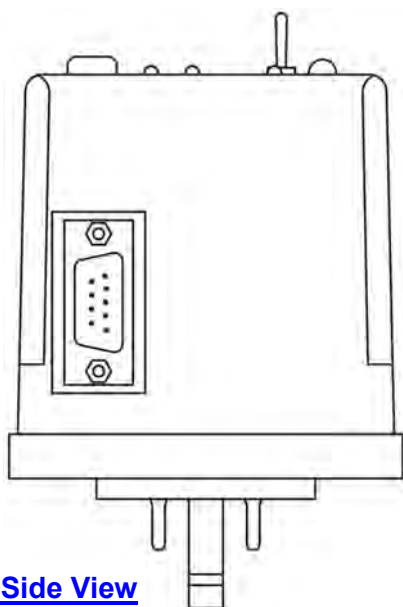

Side View

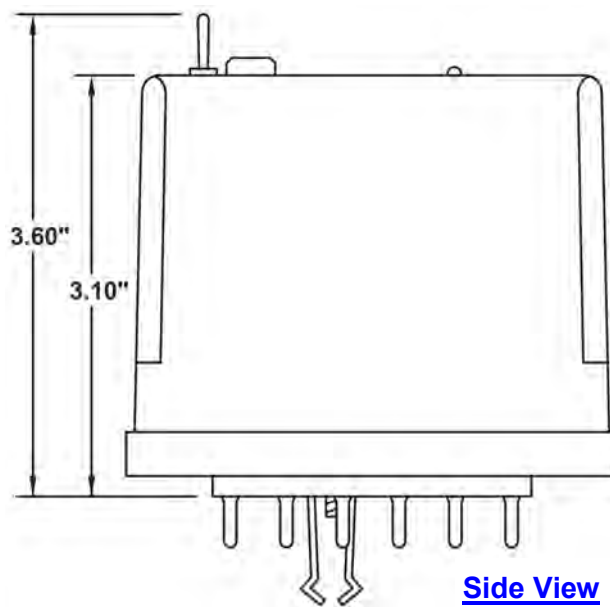

Bottom View

