

Sepra-Lite[®] Optical Level Probe

LEVELITE

Installation & Operation Instructions

Introduction:

Sepra-Lite operates by sensing the difference between liquid and air (or other gas) optically, using an infrared light source and detector. When the sensor is wetted, the transmitted light is lost into the liquid. When dry, the transmitted light is reflected by the prism back to the photo detector. This approach does not rely on any electrical interaction with the liquid; has no moving parts; and gives us two main advantages. A wide variety of applications and the ability to separate the electronics for safety and troubleshooting.

When applying Sepra-Lite, specific gravity, conductivity, vibration, and tight mounting constraints are not a problem. Dark, foggy, or colored liquids, such as: oils (light and heavy), glycols, detergents, heavy syrups, or caustics perform well. Sepra-Lite is available in Brass, and Teflon (PFA). Two different mounting types provide a leakproof and/or high pressure seal. To make using it even easier, the small overall size and minimal insertion is perfect where "in-pipe" use or "tight quarters" are encountered.

Separability of electronics module and sensor body is a key advantage. Since the sensor body is a passive part of the system, only the electronics module can cause a failure. Consequently, there is no need to shut down a machine or process when troubleshooting or repairing the Sepra-Lite. To verify operation, simply remove the electronics module and look into the "window". If it is dark, liquid is present; if light, sensor is dry. By comparing this with the unit output or LED indicator, operation is easily and safely verified. You no longer need to open tanks or remove sensors to troubleshoot or repair.

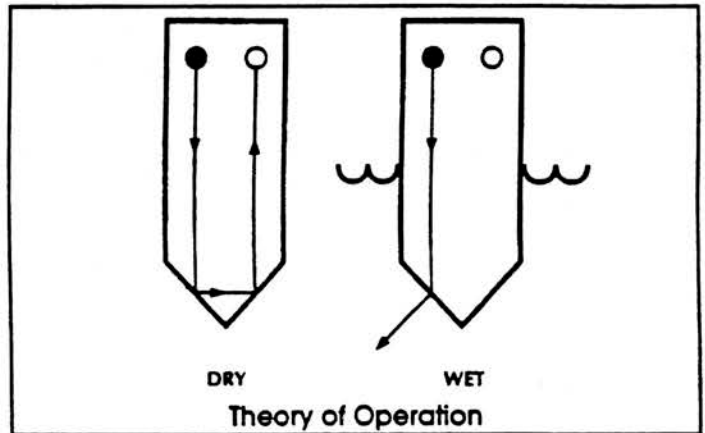

Application Considerations:

- Do not mount metal or teflon sensors with the conical tip pointed downward. Material may collect on probe and indicate a wet condition at all times. The polysulfone sensor can be mounted vertically.
- Do not use in highly aerated, reflective, or white liquids.
- Do not mount sensor where the conical tip will be "looking" directly at a reflective surface. Mounting in pipe tees of 1/2" or greater is acceptable, however; you will have to decrease the sensitivity for proper function (see "Calibration").
- Apply DC power only to this unit.
- Verify that the probe is compatible with the process, including: pressure, temperature, construction, and area classification.

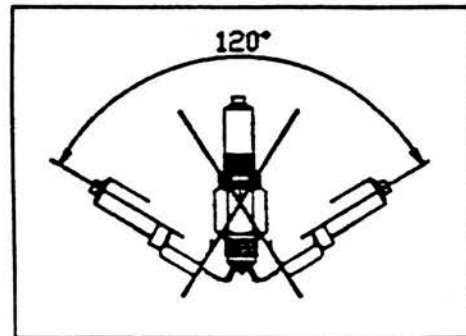

Order from: **C A Briggs Company**
622 Mary Street; Suite 101; Warminster, PA 18974
Phone: 267-673-8117 - 800-352-6265; Fax: 267-673-8118
Sales@cabriggs.com - www.cabriggs.com

Installation & Hook-Up:

Do not connect to any equipment which could cause harm until the calibration has been performed and safe operation verified. Always install per N.E.C. or local code.

- Verify mounting type. Sepra-Lite is available with either a 1/2" NPT or 3/4" - 16 UNF threaded mount (see "Specifications" is unsure).

- The electronics module must be fully seated into the rear of the sensor body (hand tighten).
- If the Teflon unit has ever been disassembled, verify that the black optic block insert is in place.

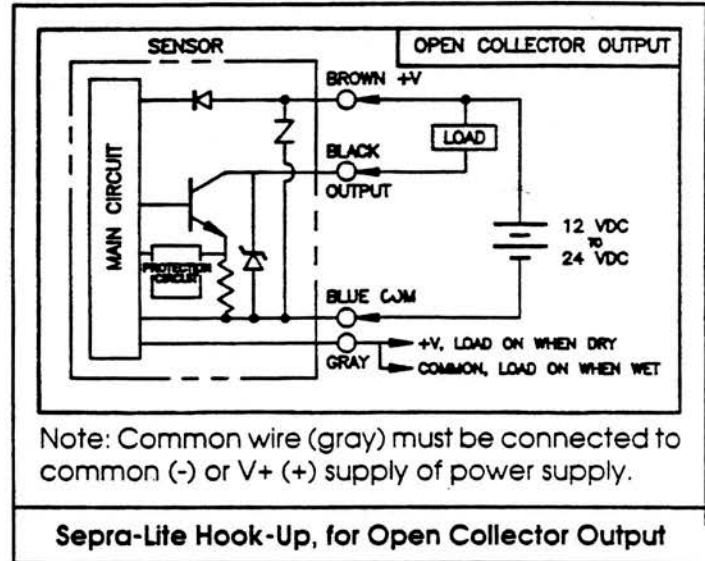
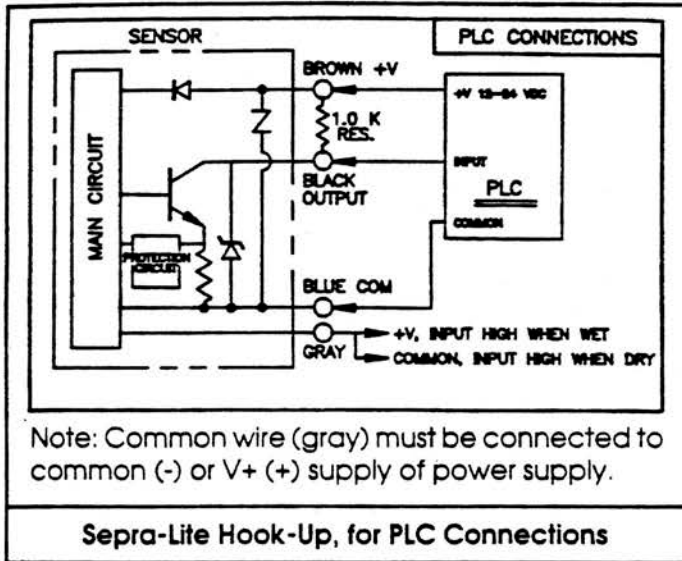

Calibration and Set-Up:

Do not connect to any equipment which could cause harm until the calibration has been performed and safe operation verified. Always install per N.E.C. or local codes.

1. Verify that the Sensitivity Adjust is set at mid position.
2. Verify that the Sepra-Lite electronics unit is fully threaded into the sensor housing.
3. Install the Sepra-Lite probe.
4. Connect the power and control (gray) wire (see chart). If the gray wire is connected to V+, the load will energize when the probe is dry. If connected to Common, the load will energize when wet. If not connected, the load will energize on a dry probe.

5. The probe LED will energize when the sensor tip is dry regardless of the control wire position. Verify that this LED does energize on a dry probe and deenergize on a wet probe. If not, see below:

- If the LED does not energize when the probe is dry, increase the sensitivity clockwise until the LED lights and continue another 5 degrees.
- If the LED is energized on a wet probe, decrease the sensitivity counterclockwise until the LED goes out and continue another 5 degrees.

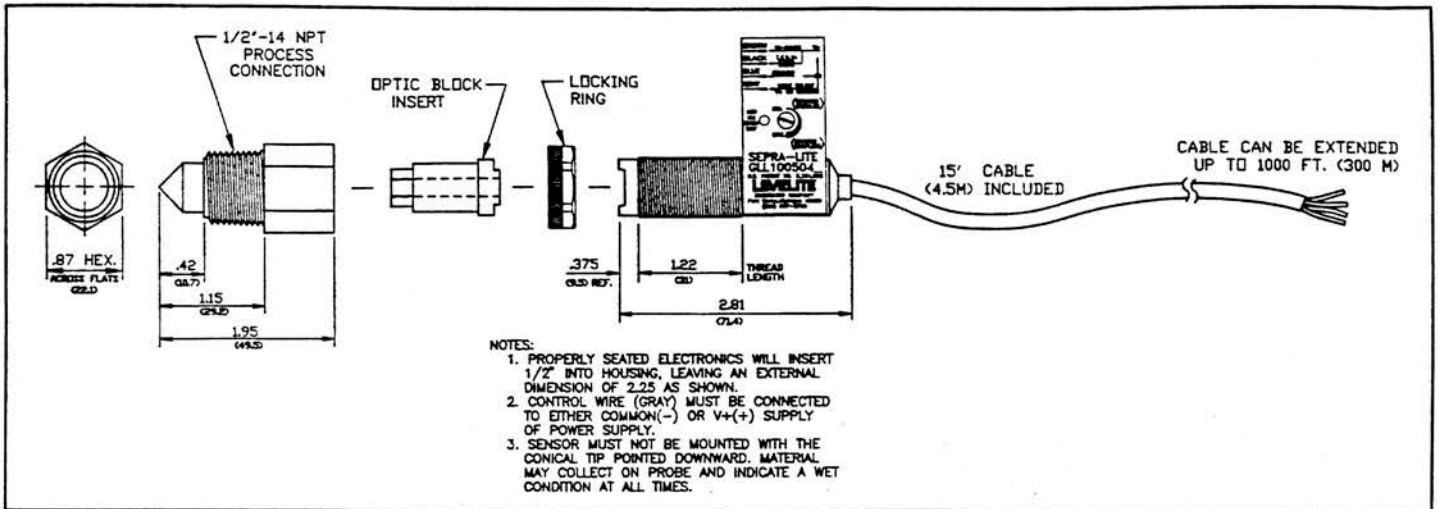

Septra-Lite Outline Drawing, 1/2"-14 NPT Molded PFA Teflon

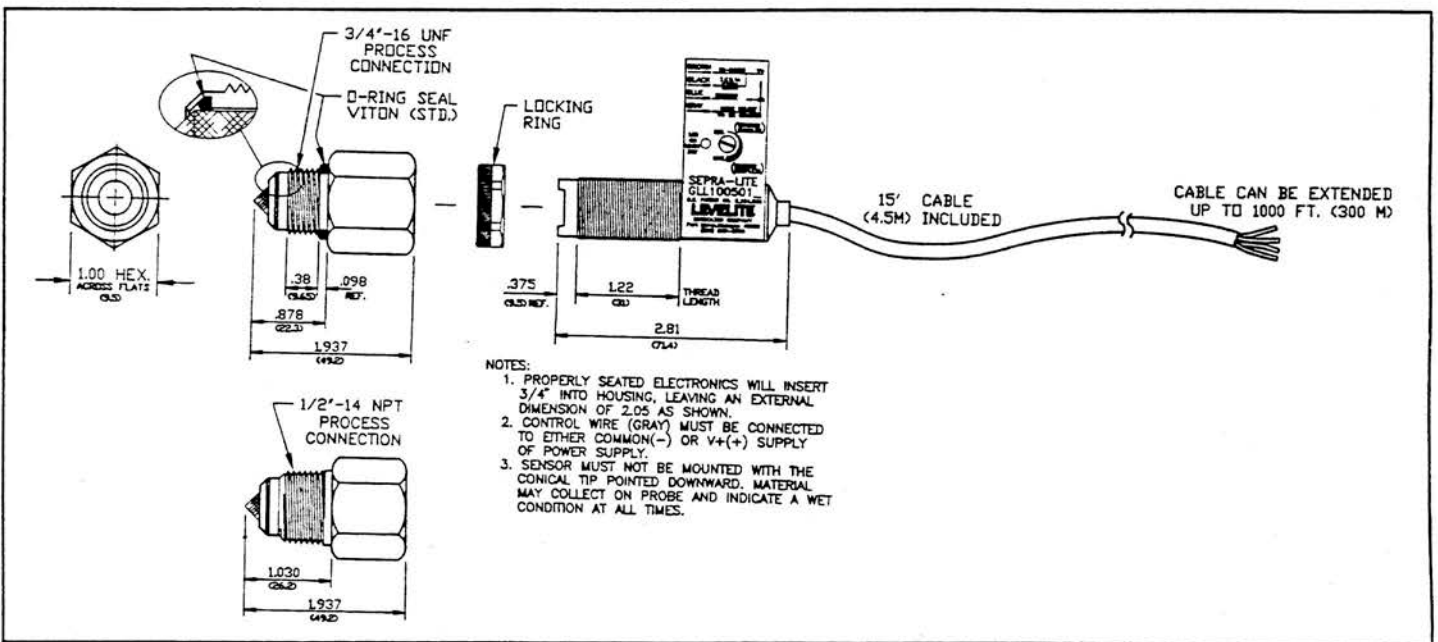

Septra-Lite Outline Drawing, 1/2"-14 NPT and 3/4"-16 UNF Metal

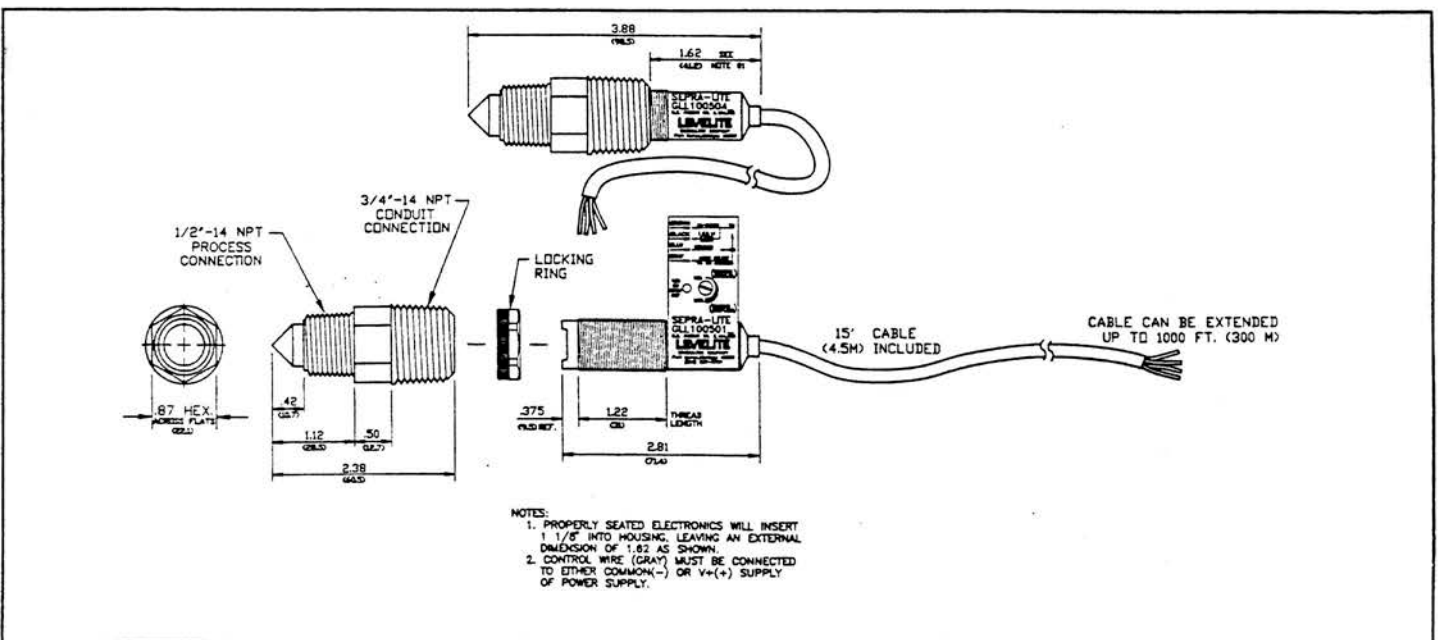

Septra-Lite Outline Drawing, 1/2"-14 NPT Polysulfone