



SCI-121 - NEMA 1, DIN Case  
SCI-122 - NEMA 4X, Plastic Enclosure  
SCI-123 - Explosion Proof Enclosure

#### Description:

The SCI is a two wire frequency to analog converter that converts a pulse rate input into a 4-20 mA output signal proportional to frequency or rate.

The input pulse rate is amplified and filtered by the input signal conditioning circuitry. Two forms of input signal conditioning are provided, one for magnetic pickups or contact closure inputs and the other is an isolated pulse input (depending on order code).

The amplified frequency signal is then converted to an analog signal using a precision frequency to analog converter.

The output stage derives its power from the output current loop. The output stage converts the analog input signal into the desired output range. Multi-turn potentiometers provide for the necessary trimming of span and zero.

#### Specifications:

##### Operating Temperature

32° F (0° C) to 158° F (70° C)

##### High Level Pulse Input

Type: Opto-Isolated  
Input Impedance: 3.3 kOhm  
Logic 1: 4-30 VDC  
Logic 0: 0-1 VDC  
Frequency Range: 0-10 kHz  
Fault Protection: Reverse Polarity Protection  
Over Voltage Protection

Isolation Voltage: 500 V  
Fast Transient Immunity: 500 V  
Maximum Rise Time: No Limit  
Maximum Fall Time: No Limit

##### Magnetic Pickup Input

Differential Input  
Input Impedance: 10 kOhm  
Frequency Response: 0-3500 Hz  
Trigger Sensitivity: 30 mV p-p  
Over Voltage Protection:  $\pm 30$  VDC

##### Contact Closure Input "L"

Sensor Compatibility- Requires an isolated, contact closure  
Maximum Contact Voltage- 5 V  
Maximum Contact Current- 0.12 mA  
Nominal Pullup Resistance - 47 Kohm to 5 Vdc  
Frequency Range - 0-100 Hz

## Frequency to Current Signal Conditioner

#### Features:

- Magnetic Pickup or Contact Closure Input
- Optically Isolated Input
- 10 kHz Maximum Input Frequency
- Standard, 2-Wire, 4-20 mA Output
- One Year Warranty
- Loop Powered
- Various Mounting Styles
- LED Indicator

#### Frequency to Current Conversion

Range Selection: DIP Switch Selectable

Available Ranges:

##### Standard

150 Hz, 300 Hz, 600 Hz, 1200 Hz,  
2500 Hz, 5000 Hz, 10,000 Hz

Factory Default: 1000 Hz

##### Contact Closure Option "L"

30 Hz, 60 Hz, 120 Hz, 240 Hz,  
480 Hz, 960 Hz, 1920 Hz

Factory Default: 100 Hz

#### Analog Output

Accuracy:  $\pm 0.1\%$  Span (@ 20° C)  
Output Type: Two Wire, Loop Powered  
Range: 4-20 mA  
Compliance Voltage: 10 to 40 VDC  
Loop Burden: < 10 VDC  
Trim Controls: Zero & Span, non-interacting  
Span (20 mA) Trim Range: 50% to 100% of full scale  
Linearity: <  $\pm 0.1\%$  Span  
Output Voltage Effect: <  $\pm 0.002\%$  Span/Volt  
Temperature Effect: < 200 PPM/C°  
Reverse Polarity Protected  
Noise Content: < 0.2% Span  
Response Time: 0.1 second (1 sec. jumper selectable)  
Overcurrent Limiting: 35 mA  
Output Loop Indicator: LED illuminates when output loop is powered by proper polarity and blinks proportionally to the input frequency.

#### Mounting Styles

DIN Rail Mount: Plastic enclosure with a snap fastener for fitting to DIN 46 277 and DIN EN 50 022 assembly rails.

NEMA 4X: 4.92" x 4.92" NEMA 4X Enclosure for wall mounting.

Explosion Proof: Aluminum enclosure for:  
Class I, Division 1, Groups B, C & D  
Class II, Division I, Groups E, F & G.

Listing: CE Compliant

## Dimensions

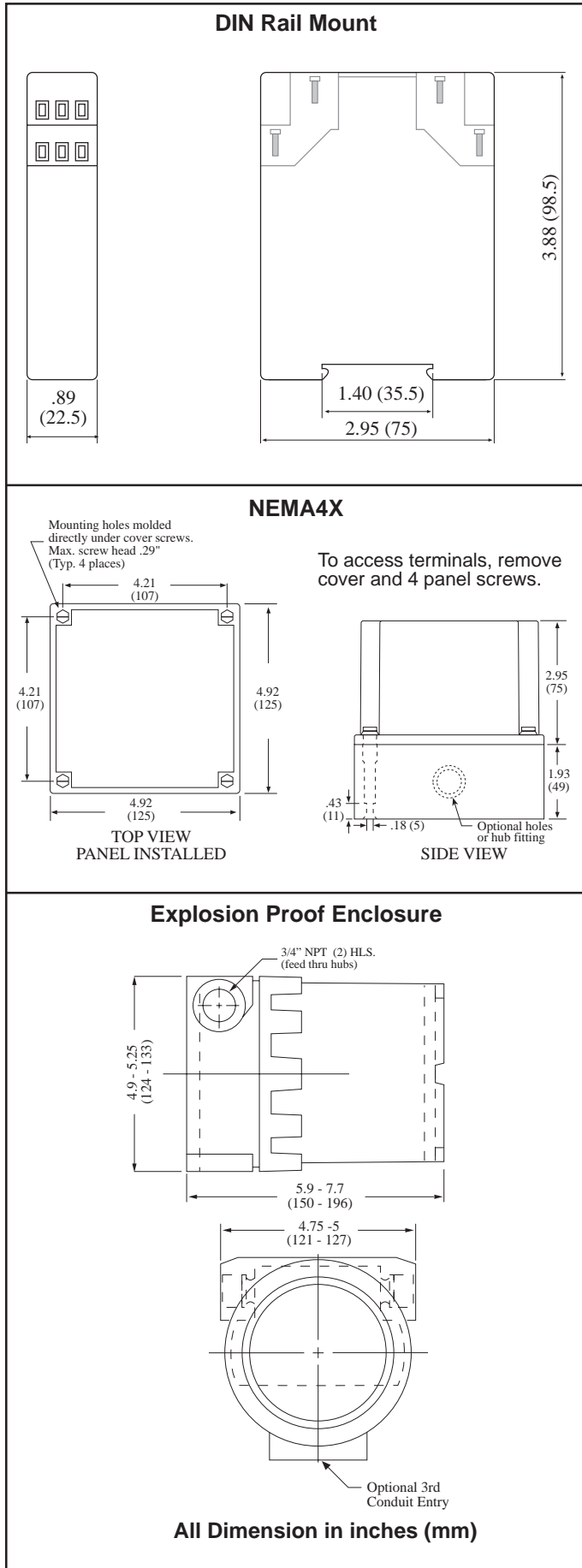

## Terminal Designations

### Standard

#### Termination

- 1• Magnetic pickup
- 2• Magnetic pickup
- 3• Shield (common)
- 4• Opto-isolator In +
- 5• Opto-isolator In -
- 6• Shield (common)
- 7• Output +
- 8• Output -
- 9• Do Not Use

### Simplified Block Diagram

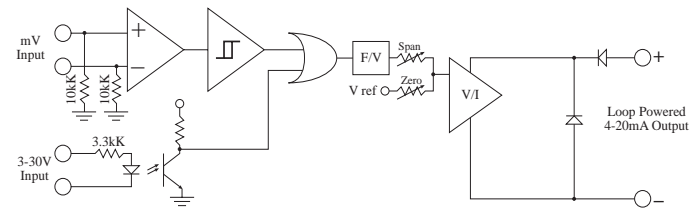

### Typical Application

#### Magnetic Pickup Input

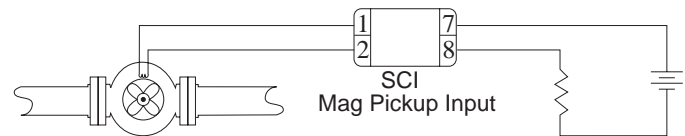

### Typical Wiring Hookup

#### Magnetic Pickup Hookup

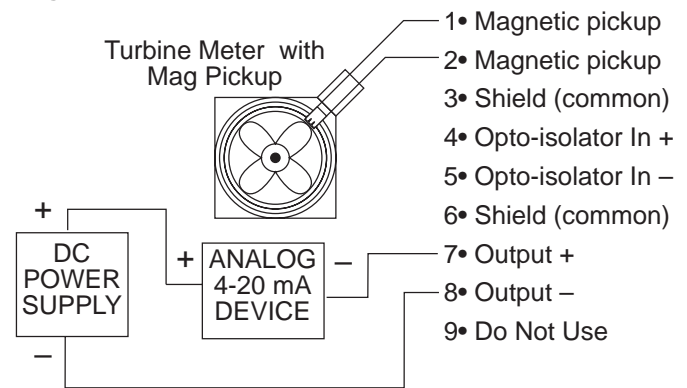

### High Level Pulse Hookup

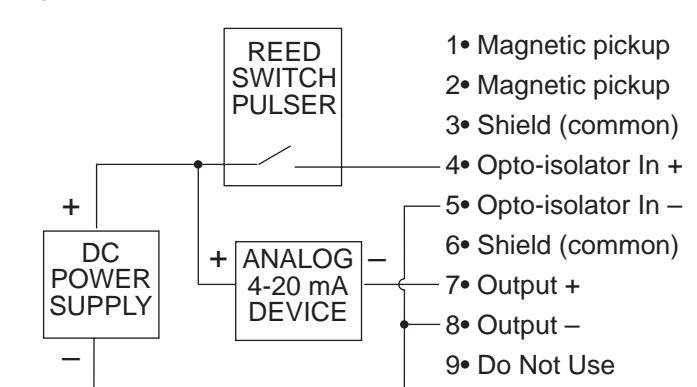

## INPUT & OUTPUT SETTINGS

**REMOVING THE CASE:**

The case must be removed to change switch settings. To remove the case proceed as follows:

Refer to FIGURE 1. Using finger tips, carefully pry the case away from the terminal blocks (as shown with dotted lines).

Pry far enough to release the restraining clips on both sides of the case.

Press up on terminal block with thumbs. The assembly will pop out allowing it to be removed from case.

**FIGURE 1:**

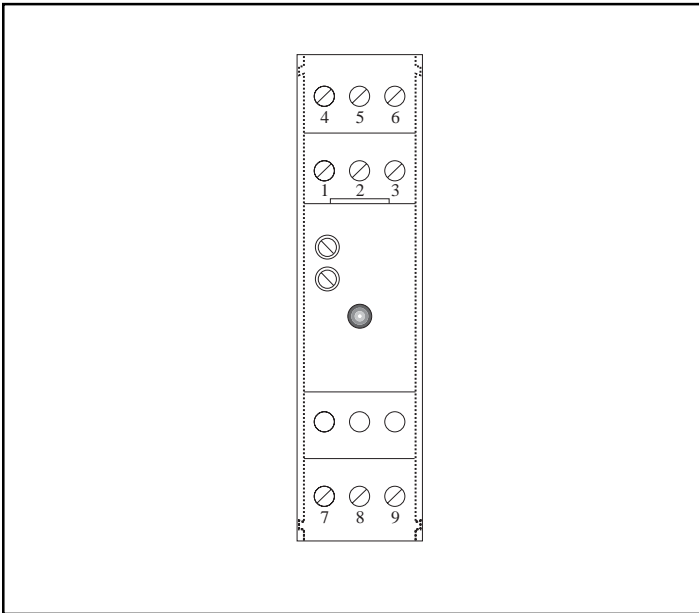

**INPUT FREQUENCY RANGE SETTINGS:**

The appropriate range is selected by turning "ON" the corresponding switch.

Range:	Switch # "ON"
0-150Hz	1
0-300Hz	2
0-600Hz	3
0-1200Hz	4*
0-2500Hz	5
0-5000Hz	6
0-10000Hz	7

\* Factory Default. The unit is setup at the factory for the range 0-1000Hz.

**OUTPUT ADJUSTMENTS:**

The unit has two potentiometers for adjustment. The upper potentiometer controls the 20mA setpoint and the lower potentiometer controls the 4mA setpoint (see Figure 2). The 4mA output range can be adjusted from 3mA to 5mA. The 20mA output range can be trimmed from 50% to 100% of the selected range. To adjust the output, initially turn the 20ma adjust 20 turns CW for starting position. Input 0 frequency and adjust the 4 mA pot. Connect your maximum frequency and adjust the 20 mA pot.

**FIGURE 2:**

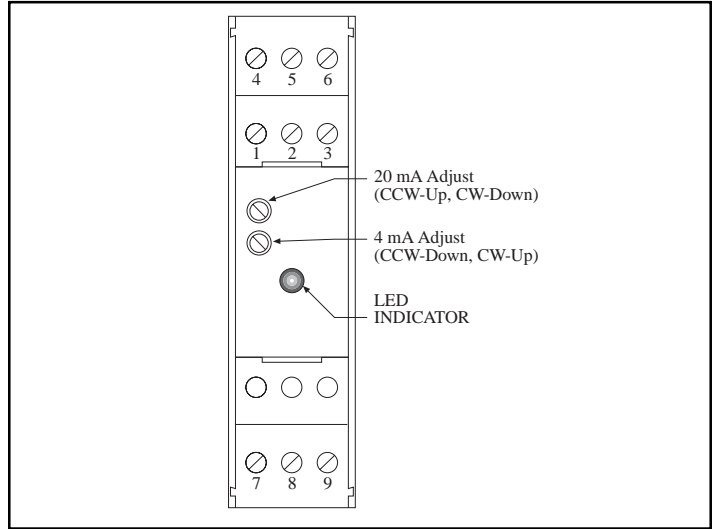

**RESPONSE TIME SETTING:**

Switch #8 controls the output response time.

Switch #8	Response Time
OFF	0.1 second
ON	1 second

Turn switch #8 ON to provide damping of the output resulting in a 1 second response time.

**LED INDICATOR:**

The SCI has a LED which indicates the status of the unit. The table below describes the 3 states for the LED.

LED STATUS:	MEANING:
OFF	The unit is off.
ON (constant)	The unit is loop powered.

**BLINKING** The unit is receiving an input frequency. The LED will blink at a rate proportional to the input frequency. (The LED may appear to be constant at high input frequencies)

# "L" Option SPECIFICATIONS

## Description:

The SCI with option "L" is a two wire frequency to analog converter that converts a pulse rate input into a 4-20 mA output signal proportional to frequency or rate.

The SCI with option "L" is intended for use with lower full scale input frequencies. Full scale frequencies of 15 Hz to 2000 Hz are possible. The unit includes both a contact closure input and an opto-isolated input. Output response time is selectable 1 or 10 seconds.

The amplified frequency signal is then converted to an analog signal using a precision frequency to analog converter.

The output stage derives it's power from the output current loop. The output stage converts the input signal into the desired output range. Multi-turn potentiometers provide for the necessary trimming of span and zero.

## SPECIFICATIONS:

### Operating Temperature

32° F (0°C) to 158°F (70°C)

### High Level Pulse Input

- Type: Opto-Isolated
- Logic 1: 4-30 VDC
- Logic 0: 0-1 VDC
- Frequency Range: 0-10 kHz
- Fault Protection: Reverse Polarity Protection  
Over Voltage Protection
- Isolation Voltage: 500 V
- Fast Transient Immunity: 500 V
- Maximum Rise Time: No Limit
- Maximum Fall Time: No Limit

### Contact Closure Input

- Sensor Compatibility- Requires an isolated, contact closure
- Maximum Contact Voltage- 5 V
- Maximum Contact Current- 0.12 mA
- Nominal Pullup Resistance - 47 Kohm to 5 Vdc
- Frequency Range - 0-100 Hz

### Frequency to Current Conversion

- Range Selection: DIP Switch Selectable
- Available Ranges: 30 Hz, 60 Hz, 120 Hz, 240 Hz,  
480 Hz, 960 Hz, 1920 Hz
- Factory Default: 100 Hz

### Simplified Block Diagram

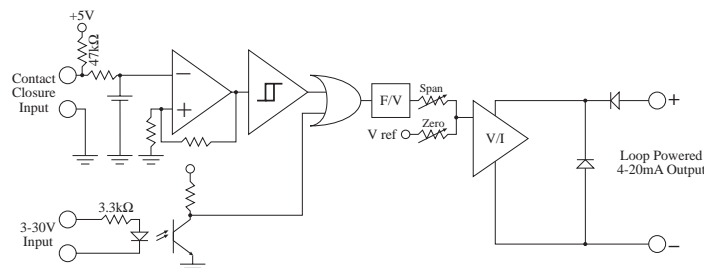

## Analog Output

- Accuracy:  $\pm 0.1\%$  Span (@ 20° C)
- Output Type: Two Wire, Loop Powered
- Range: 4-20 mA (10 - 50 mA optional)
- Compliance Voltage: 10 to 40 VDC
- Loop Burden: < 10 VDC (less than 500  $\Omega$ )
- Trim Controls: Zero & Span, non-interacting
- Span (20 mA) Trim Range: 50% to 100% of full scale
- Linearity: <  $\pm 0.1\%$  Span
- Output Voltage Effect: <  $\pm 0.002\%$  Span/Volt
- Temperature Effect: < 200 PPM/C°
- Reverse Polarity Protected
- Noise Content: < 0.2% Span
- Response Time: 1 second (10 sec. jumper selectable)
- Over-current Limiting: 35 mA
- Output Loop Indicator: LED illuminates when output loop is powered by proper polarity and blinks proportionally to the input frequency.

## Mounting Styles

- DIN Rail Mount: Plastic enclosure with a snap fastener for fitting to DIN 46 277 and DIN EN 50 022 assembly rails.
- NEMA 4X: 4.92" x 4.92" NEMA 4X Enclosure for wall mounting.
- Explosion Proof: Aluminum enclosure for:  
Class I, Division 1, Groups B, C & D  
Class II, Division I, Groups E, F & G.

## Typical Wiring Hookup (option "L")

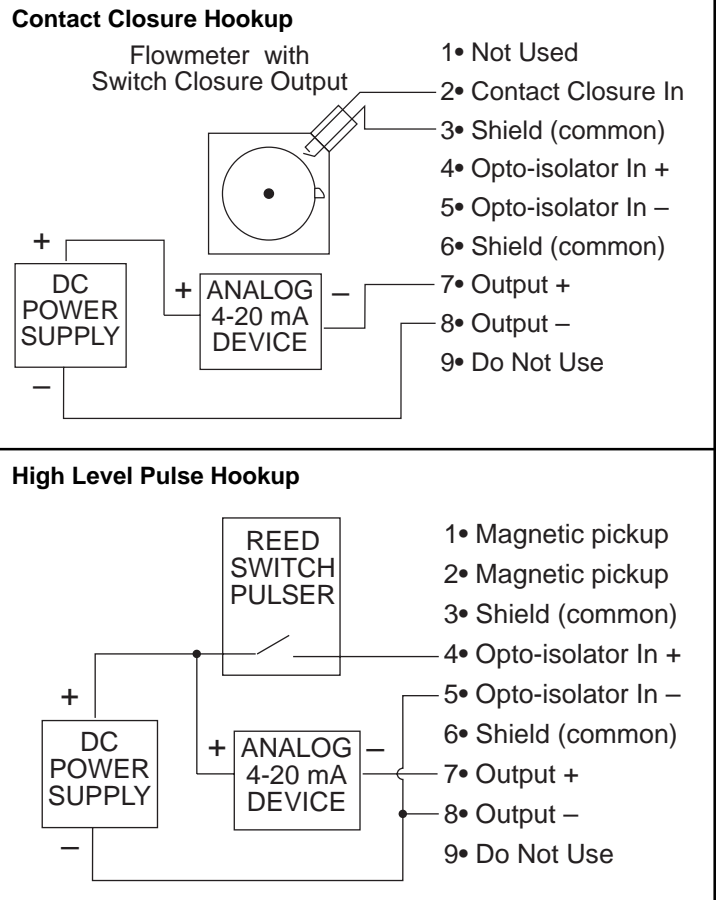

## "L" Option INPUT & OUTPUT SETTINGS

### REMOVING THE CASE:

The case must be removed to change switch settings. To remove the case proceed as follows:

Refer to FIGURE 1. Using finger tips, carefully pry the case away from the terminal blocks (as shown with dotted lines).

Pry far enough to release the restraining clips on both sides of the case.

Press up on terminal block with thumbs. The assembly will pop out allowing it to be removed from case.

**FIGURE 1:**

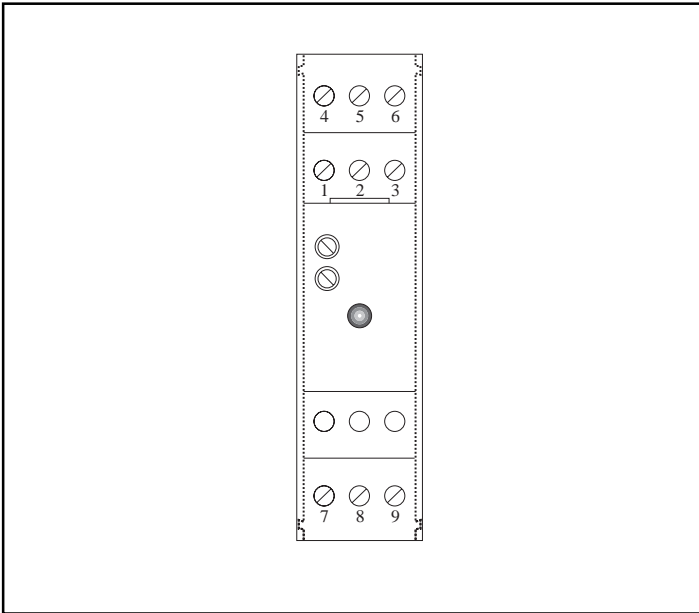

### OUTPUT ADJUSTMENTS:

The unit has two potentiometers for adjustment. The upper potentiometer controls the 20mA setpoint and the lower potentiometer controls the 4mA setpoint (see Figure 2). The 4mA output range can be adjusted from 3mA to 5mA. The 20mA output range can be trimmed from 50% to 100% of the selected range. To adjust the output, initially turn the 20mA adjust 20 turns CW for starting position. Input 0 frequency and adjust the 4 mA pot. Connect your maximum frequency and adjust the 20 mA pot.

**FIGURE 2:**

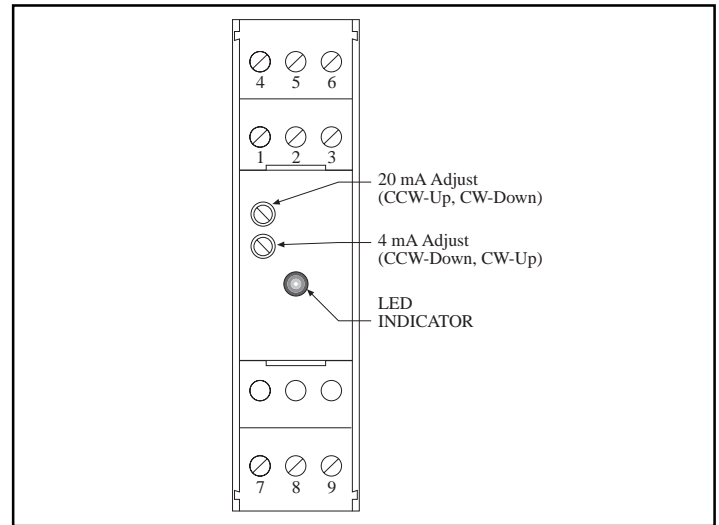

### RESPONSE TIME SETTING:

Switch #8 controls the output response time.

<u>Switch #8</u>	<u>Response Time</u>
OFF	1 second
ON	10 seconds

Turn switch #8 ON to provide damping of the output resulting in a 10 second response time.

### INPUT FREQUENCY RANGE SETTINGS:

The appropriate range is selected by turning "ON" the corresponding switch.

<u>Range:</u>	<u>Switch # "ON"</u>
0-30Hz	1
0-60Hz	2
0-120Hz	3*
0-240Hz	4
0-480Hz	5
0-960Hz	6
0-1920Hz	7

\* Factory Default. The unit is setup at the factory for the range 0-100Hz.

### LED INDICATOR:

The SCI-L has a LED which indicates the status of the unit. The table below describes the 3 states for the LED.

<u>LED STATUS:</u>	<u>MEANING:</u>
OFF	The unit is off.
ON (constant)	The unit is loop powered.

**BLINKING** The unit is receiving an input frequency. The LED will blink at a rate proportional to the input frequency. (The LED may appear to be constant at high input frequencies)