

Operating Instructions for Differential Pressure Flow Meter / Monitor

Model: RCD-...



Order from: **C A Briggs Company**
622 Mary Street; Suite 101; Warminster, PA 18974
Phone: 267-673-8117 - Fax: 267-673-8118
Sales@cabriggs.com - www.cabriggs.com

1. Contents

1. Contents.....	2
2. Note	3
3. Instrument Inspection.....	3
4. Regulation Use.....	4
5. Operating Principle.....	4
6. Mechanical Connection.....	4
6.1. Check Service Conditions.....	4
6.2. Installation.....	5
7. Electrical Connection	6
7.1. Mechanical Pointer Indication (..Z...)	6
7.2. Compact Electronics: (..C30R, ..C30M, ..C34P, ..C34N).....	6
7.3. ADI Electronic	6
8. Commissioning.....	6
8.1. Mechanical Pointer Indication (..Z...)	6
8.2. Setting Compact Electronics.....	6
8.3. Setting ADI Electronic.....	6
9. Maintenance	7
10. Technical Information.....	7
10.1. Sensor Data.....	7
10.2. Displays/Electronics.....	7
11. Order Details.....	9
12. Dimensions	11
13. EU Declaration of Conformance.....	12

Manufactured and sold by:

Kobold Messring GmbH
Nordring 22-24
D-65719 Hofheim
Tel.: +49(0)6192-2990
Fax: +49(0)6192-23398
E-Mail: info.de@kobold.com
Internet: www.kobold.com

2. Note

Please read these operating instructions before unpacking and putting the unit into operation. Follow the instructions precisely as described herein.

The devices are only to be used, maintained and serviced by persons familiar with these operating instructions and in accordance with local regulations applying to Health & Safety and prevention of accidents.

When used in machines, the measuring unit should be used only when the machines fulfil the EC-machine guidelines.

as per PED 2014/68/EU

In acc. with Article 4 Paragraph (3), "Sound Engineering Practice", of the PED 2014/68/EU no CE mark.

	Pipe	
	Diagram 7 group 1 no dangerous fluids	Diagram 6 group 2 dangerous fluids
RCD-..05 - RCD..30	Art. 4, § 3	Art. 4, § 3
RCD-1135, RCD-1140	Art. 4, § 3	Cat. I
RCD-1235, RCD-1240	Cat. I	Cat. II
RCD-1145, RCD-1150	Art. 4, § 3	Cat. I
RCD-1245, RCD-1250	Cat. I	Cat. II
RCD-1155, RCD-1160, RCD-1165	Cat. I	not deliverable
RCD-1260, RCD-1265	Cat. I	Cat. II

3. Instrument Inspection

Instruments are inspected before shipping and sent out in perfect condition. Should damage to a device be visible, we recommend a thorough inspection of the delivery packaging. In case of damage, please inform your parcel service / forwarding agent immediately, since they are responsible for damages during transit.

Scope of delivery:

The standard delivery includes:

- Differential Pressure Flow Meter / Monitor model: RCD
- Operating Instructions

4. Regulation Use

Any use of the Differential Pressure Flow Meter / Monitor, model: RCD, which exceeds the manufacturer's specification may invalidate its warranty. Therefore any resulting damage is not the responsibility of the manufacturer. The user assumes all risk for such usage.

5. Operating Principle

The Kobold Flow Meter is used for measuring and monitoring the flow velocity of liquids and gases. The device works in accordance with the well-known principle of the Venturi nozzle. A small pressure difference proportional to the flow is produced by the flowing medium at a cross-sectional constriction (nozzle) in the device housing. The shape of the nozzle is based on the particular flow value whereby flow characteristic remains constant over the entire measuring range. Pressure sensing ports are located in the flow body to measure the resulting differential pressure and send it to a differential-pressure measuring cell fitted in the display case. If the flow is exceeded, the differential-pressure measuring cell is protected by mechanical stops. In the case of mechanical displays the flow rate measured by the differential pressure measuring cell is indicated on a pointer element which is calibrated in l/min water or Nm³/h air. On electronic displays the mechanical motion is converted to an electrical signal by a Hall sensor. The electronics serves to display and monitor the volumetric flow.

6. Mechanical Connection

6.1. Check Service Conditions

- Flow
- Max. operating pressures
- Max. operating temperature
- Medium
- Mounting position

When the medium is not in our substance database:

- operating density
- operating viscosity

6.2. Installation

- Flow in direction of arrow (universal)
- Avoid pressure and tensile loads
mount inlet and outlet piping at distances of 50 mm from the connections
- Check connections for leaks
- Pay attention to the inlet and outlet path (see drawings below)

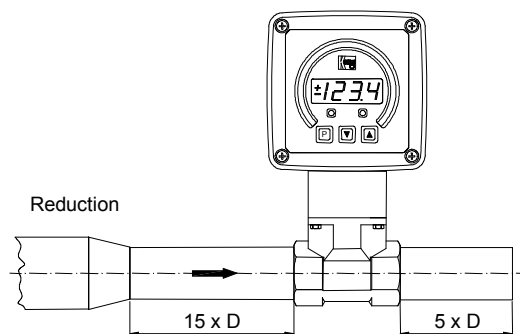
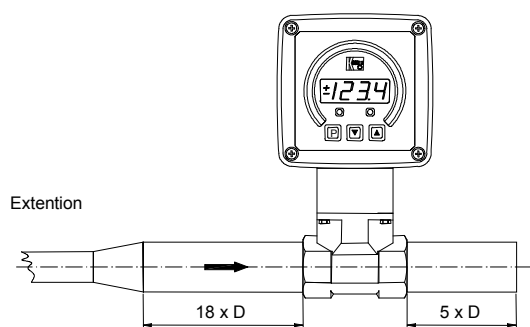
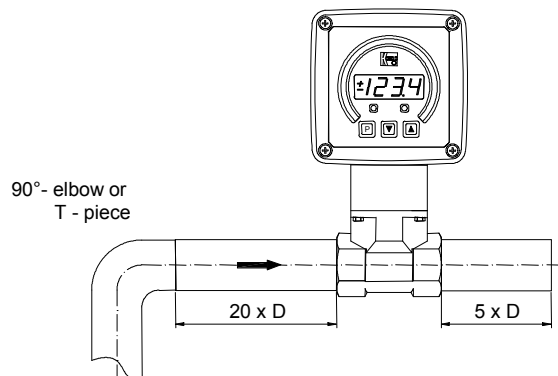
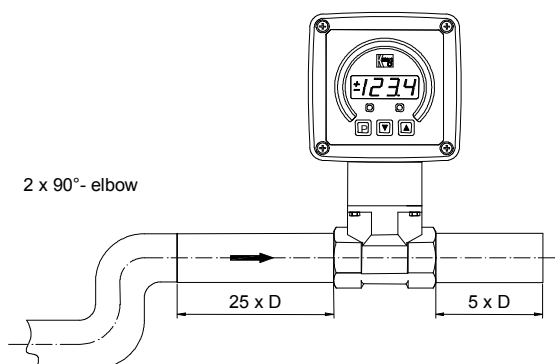
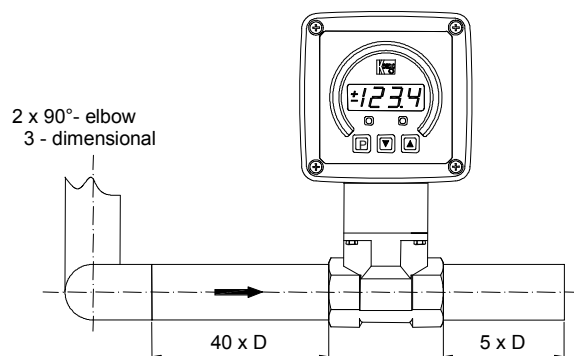
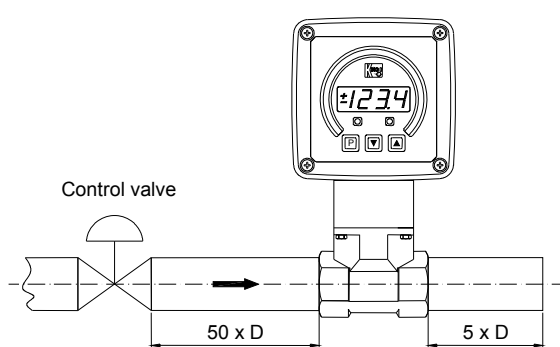

7. Electrical Connection

7.1. Mechanical Pointer Indication (..Z...)

without electrical connection

7.2. Compact Electronics: (..C30R, ..C30M, ..C34P, ..C34N)

see
Operating instructions supplement
for compact electronics with frequency output

7.3. ADI Electronic

see
Operating instructions supplement
for ADI electronic display

8. Commissioning

8.1. Mechanical Pointer Indication (..Z...)



Attention! Remove transportation safety screw and screw in the sealing screw from the bag into the thread M3.

8.2. Setting Compact Electronics

see
Operating instructions supplement
for compact electronics with frequency output

8.3. Setting ADI Electronic

see
Operating instructions supplement
for ADI electronic display

9. Maintenance

The measuring instrument requires no maintenance when the measured medium leaves no deposits. To prevent fouling the flow meter pressure sensing ports, we recommend that a filter is installed, for example the magnetic filter, model MFR. Work on the sensor and electronics should only be carried out by the supplier, otherwise the warranty is void.

10. Technical Information

10.1. Sensor Data

Measuring range:	see name plate
Measuring accuracy:	3 % of F.S.
Reproducibility:	1 % of F.S.
Process temperature:	RCD... mechanical: -20 °C...+100 °C RCD... electronic: -20 °C...+80 °C
Ambient temperature:	max. 80 °C
Max. operating pressure:	25 bar (RCD-1155, RCD-1160, RCD-1165) 40 bar (all others)
Protection:	IP 65

Materials:

Flow housing:	RCD-x1...: brass casting RCD-x2...: stainless steel 1.4581
Differential pressure housing:	RCD-x1...: brass casting RCD-x2...: stainless steel 1.4571
Pressure measuring cell:	stainless steel 1.4571
Venturi nozzle:	stainless steel 1.4571
Gaskets:	RCD-x1...: NBR RCD-x2...: FPM

10.2. Displays/Electronics

Mechanical pointer indication:

Display:	270 °
Display case:	aluminium / polyamide
Front cover:	polycarbonate
Option:	special scales for other gases and liquids. Please specify medium, density, viscosity, operating pressure and temperature

Compact electronics:

Display:	3-digit LED
Analogue output:	(0) 4 - 20 mA adjustable, max. 500 Ω
Switching outputs:	1 (2) semiconductor PNP or NPN, factory set
Contact operation:	N/C / N/O frequency programmable
Setting:	via 2 buttons
Supply:	24 V _{DC} \pm 20 %, 3-wire, approx. 100 mA
Electrical connection:	plug connector M12 x 1

ADI electronics

Display:	bar graph and 5-digit digital display
Analogue output:	(0)4-20 mA, 0-10 V _{DC}
Two switching outputs:	relay/changeover contacts max. 250 V _{AC} /5 A resistive load, max. 30 V _{DC} / 5 A
Setting:	via 4 buttons
Power supply:	100...240 V _{AC} \pm 10% or 18...30 V _{AC} /10...40 V _{DC}
Electrical connection:	pluggable terminal block via cable gland

11. Order Details

Order details (example: RCD 1195H G4 K 0 0 0)

Meas. range water [L/min]	Orifice Ø [mm]	Model		Connection	
		Material brass casting	Material st. steel	G-thread	NPT
0.5...3.3	2.80	RCD 1195H	RCD 1295H	G4 = G 1/2	N4 = 1/2 NPT
0.5...4.2	3.15	RCD 1100H	RCD 1200H		
0.5...5.2	3.50	RCD 1190H	RCD 1290H		
1.0...6.8	4.00	RCD 1191H	RCD 1291H		
1.0...8.6	4.50	RCD 1101H	RCD 1201H		
1.0...10.6	5.00	RCD 1192H	RCD 1292H		
2.0...13.2	5.60	RCD 1102H	RCD 1202H	G4 = G 1/2 G5 = G 3/4	N4 = 1/2 NPT N5 = 3/4 NPT
2.0...16.8	6.30	RCD 1103H	RCD 1203H		
2.0...21.4	7.10	RCD 1104H	RCD 1204H		
3.0...27.0	8.00	RCD 1106H	RCD 1206H	G4 = G 1/2 G5 = G 3/4 G6 = G 1	N4 = 1/2 NPT N5 = 3/4 NPT N6 = 1 NPT
5.0...34.5	9.00	RCD 1109H	RCD 1209H		
5.0...42.4	10.00	RCD 1110H	RCD 1210H		
10.0...58.0	11.20	RCD 1114H	RCD 1214H	G5 = G 3/4 G6 = G 1	N5 = 3/4 NPT N6 = 1 NPT
10.0...66.0	12.50	RCD 1115H	RCD 1215H		
10.0...85.0	14.00	RCD 1116H	RCD 1216H		
20.0...118	16.00	RCD 1117H	RCD 1217H	G6 = G 1 G8 = G 1 1/2	N6 = 1 NPT N8 = 1 1/2 NPT
20.0...132	17.50	RCD 1125H	RCD 1225H		
20.0...148	18.00	RCD 1126H	RCD 1226H		
20.0...168	19.20	RCD 1130H	RCD 1230H	G8 = G 1 1/2 G9 = G 2	N8 = 1 1/2 NPT N9 = 2 NPT
30.0...275	26.00	RCD 1135H	RCD 1235H		
50.0...350	28.00	RCD 1137H	RCD 1237H		
50.0...435	31.00	RCD 1139H	RCD 1239H	G9 = G 2 GB = G 3	N9 = 2 NPT NB = 3 NPT
100...700	40.00	RCD 1145H	RCD 1245H		
100...910	43.50	RCD 1150H	RCD 1250H		
100...1060	51.00	RCD 1155H	RCD 1255H	GB = G 3	NB = 3 NPT
200...1540	60.00	RCD 1160H	RCD 1260H		
300...2350	67.00	RCD 1165H	RCD 1265H		

Evaluating electronics			
Mechanical pointer indication			
Indication	Flow direction		Location of ind.
Z = pointer indicat., 270 °	L = from left R = from right B = from bottom		L = left R = right T = top B = bottom
ADI-electronics**			
Indication	Supply	Output	Contacts
K = bargraph /digital	0 = 100-240 V _{AC/DC} 3 = 18-30 V _{AC} 10-40 V _{AC}	0 = without 4 = (0)4-20 mA, 0-10 V	2 = 2 changeover contacts
Compact electronics**			
Indication	Supply	Output/contacts	
C = digital	3 = 24 V _{DC}	0R = 2 x Open Collector, PNP 0M = 2 x Open Collector, NPN 4P = 4-20 mA, 1 x Open Coll. PNP 4N = 4-20 mA; 1 x Open Coll. NPN	

** Please specify flow direction in the order (expect from top to bottom)

Please specify the operating conditions in the order

Order details (example: RCD 1195L G4 K 0 0 0)

Range air 1 bar abs. / 20 °C [m ³ _N /h]*	Orifice Ø [mm]	Model		Connection	
		Material Alu bronze	Material st. steel	G-thread	NPT
0.50...5.35	2.80	RCD 1195L	RCD 1295L	G4 = G 1/2	N4 = 1/2 NPT
1.00...6.70	3.15	RCD 1100L	RCD 1200L		
1.00...8.30	3.50	RCD 1190L	RCD 1290L		
1.00...10.9	4.00	RCD 1191L	RCD 1291L		
2.00...13.8	4.50	RCD 1101L	RCD 1201L		
2.00...17.0	5.00	RCD 1192L	RCD 1292L	G4 = G 1/2 G5 = G 3/4	N4 = 1/2 NPT N5 = 3/4 NPT
2.00...21.4	5.60	RCD 1102L	RCD 1202L		
3.00...27.0	6.30	RCD 1103L	RCD 1203L	G4 = G 1/2 G5 = G 3/4 G6 = G 1	N4 = 1/2 NPT N5 = 3/4 NPT N6 = 1 NPT
5.00...34.5	7.10	RCD 1104L	RCD 1204L		
5.00...43.5	8.00	RCD 1106L	RCD 1206L		
10.0...55.0	9.00	RCD 1109L	RCD 1209L	G5 = G 3/4 G6 = G 1	N5 = 3/4 NPT N6 = 1 NPT
10.0...68.0	10.00	RCD 1110L	RCD 1210L		
10.0...78.0	11.20	RCD 1114L	RCD 1214L	G5 = G 3/4 G6 = G 1	N5 = 3/4 NPT N6 = 1 NPT
10.0...97.0	12.50	RCD 1115L	RCD 1215L		
20.0...116	14.00	RCD 1116L	RCD 1216L	G6 = G 1 G8 = G 1 1/2	N6 = 1 NPT N8 = 1 1/2 NPT
20.0...158	16.00	RCD 1117L	RCD 1217L		
20.0...188	17.50	RCD 1125L	RCD 1225L	G6 = G 1 G8 = G 1 1/2	N6 = 1 NPT N8 = 1 1/2 NPT
20.0...198	18.00	RCD 1126L	RCD 1226L		
30.0...225	19.20	RCD 1130L	RCD 1230L	G8 = G 1 1/2 G9 = G 2	N8 = 1 1/2 NPT N9 = 2 NPT
50.0...375	26.00	RCD 1135L	RCD 1235L		
50.0...515	28.00	RCD 1137L	RCD 1237L	G9 = G 2 GB = G 3	N9 = 2 NPT NB = 3 NPT
100...630	31.00	RCD 1139L	RCD 1239L		
100...910	40.00	RCD 1145L	RCD 1245L	G9 = G 2 GB = G 3	N9 = 2 NPT NB = 3 NPT
200...1160	43.50	RCD 1150L	RCD 1250L		
200...1360	51.00	RCD 1155L	RCD 1255L	GB = G 3	NB = 3 NPT
400...2000	60.00	RCD 1160L	RCD 1260L		
300...2750	67.00	RCD 1165L	RCD 1265L		

* m³_N/h correspond to a flow rate at 0 °C; 1013 mbar

Evaluating electronics			
Mechanical pointer indication			
Indication	Flow direction		Location of ind.
Z = pointer indicat., 270 °	L = from left R = from right B = from bottom		L = left R = right T = top B = bottom
ADI-electronics**			
Indication	Supply	Output	Contacts
K = bargraph /digital	0 = 100-240 V _{AC/DC} 3 = 18-30 V _{AC} 10-40 V _{AC}	0 = without 4 = (0)4-20 mA, 0-10 V	2 = 2 changeover contacts
Compact electronics**			
Indication	Supply	Output/contacts	
C = digital	3 = 24 V _{DC}	0R = 2 x Open Collector, PNP 0M = 2 x Open Collector, NPN 4P = 4-20 mA, 1 x Open Coll. PNP 4N = 4-20 mA; 1 x Open Coll. NPN	

** Please specify flow direction in the order (expect from top to bottom)

Please specify the operating conditions in the order

12. Dimensions

RCD...Z with mechanical display

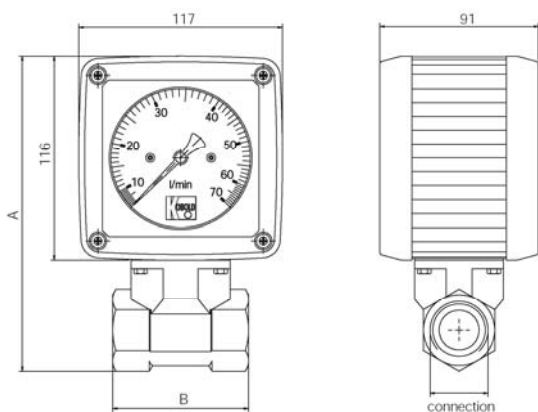

Screw thread	A	B	C	D	Weight (approx.)
G 1/2	191	78	hex 27	143	ca. 2,0 kg
G 3/4	191	78	hex 41	143	ca. 2,3 kg
G1	191	78	hex 41	143	ca. 2,2 kg
G 1 1/2	206	78	hex 55	158	ca. 2,6 kg
G 2	204	81	hex 70	156	ca. 2,8 kg
G3	221	106	hex 100	173	ca. 5,1 kg

RCD...C with compact electronics

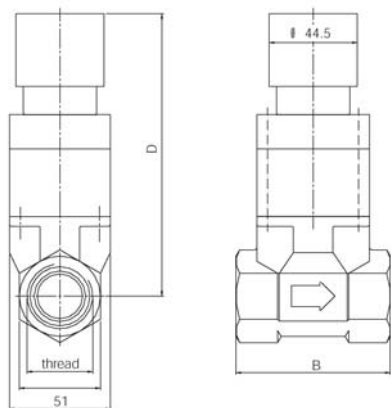

Screw thread	A	B	C	D	Weight (approx.)
G 1/2	191	78	hex 27	143	ca. 2,1 kg
G 3/4	191	78	hex 41	143	ca. 2,4 kg
G1	191	78	hex 41	143	ca. 2,2 kg
G 1 1/2	206	78	hex 55	158	ca. 2,6 kg
G 2	204	81	hex 70	156	ca. 2,9 kg
G3	221	106	hex 100	173	ca. 5,2 kg

RCD...K with ADI electronic

(same dimensions for RCD...D and RCD...K)

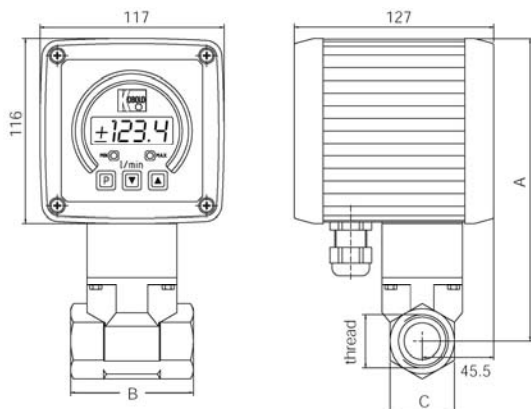

Screw thread	A	B	C	D	Weight (approx.)
G 1/2	191	78	hex 27	143	ca. 3,4 kg
G 3/4	191	78	hex 41	143	ca. 3,7 kg
G1	191	78	hex 41	143	ca. 3,6 kg
G 1 1/2	206	78	hex 55	158	ca. 3,9 kg
G 2	204	81	hex 70	156	ca. 4,2 kg
G3	221	106	hex 100	173	ca. 6,5 kg

13. EU Declaration of Conformance

We, KOBOLD-Messring GmbH, Hofheim-Ts, Germany, declare under our sole responsibility that the product:

Differential Pressure Flow Meter / Monitor model: RCD -...

to which this declaration relates is in conformity with the standards noted below:

EN 61000-6-4:2011

Electromagnetic compatibility (EMC) - Part 6-4: Generic standards - Emission standard for industrial environments

EN 61000-6-2:2005

Electromagnetic compatibility (EMC) - Part 6-2: Generic standards - Immunity for industrial environments

EN 61010-1:2010

Safety requirements for electrical equipment for measurement, control and laboratory use - Part 1: General requirements

EN 60529:2014

Degrees of protection provided by enclosures (IP Code)

EN 50581:2012

Technical documentation for the assessment of electrical and electronic products with respect to the restriction of hazardous substances

in accordance with the general requirements of the guideline

2014/35/EU	Low Voltage Directive
2014/30/EU	EMC Directive
2011/65/EU	RoHS (category 9)

2014/68/EU	PED
	<ul style="list-style-type: none">• Category III (IV) Diagram 1, vessel, group 1 dangerous fluids• Module D, marking CE0575• Notified body: DNV GL• Certificate No. PEDD000000R



H. Peters
General Manager



M. Wenzel
Proxy Holder

Hofheim, 02. Aug. 2018