

Operating Instructions for Optical Level Sensor

Model: OPT



Order from: **C A Briggs Company**
622 Mary Street; Suite 101; Warminster, PA 18974
Phone: 267-673-8117 - Fax: 267-673-8118
Sales@cabriggs.com - www.cabriggs.com

1. Contents

1. Contents.....	2
2. Note	3
3. Instrument Inspection.....	3
4. Regulation Use.....	3
5. Operating Principle.....	4
6. Mechanical Connection.....	4
6.1. Process Connection M14 with Nut (OPT-..10)	5
6.2. Process Connection G ½ (OPT-..22)	5
7. Electrical Connection	6
7.1. General Information	6
7.2. Terminal Connection Diagrams	6
8. Technical Information.....	8
9. Order Codes	9
10. Dimensions	9
11. EU Declaration of Conformance.....	10

Manufactured and sold by:

Kobold Messring GmbH
Nordring 22-24
D-65719 Hofheim, Germany
Tel.: +49 (0)6192-2990
Fax: +49(0)6192-23398
E-mail: info.de@kobold.com
Internet: www.kobold.com

2. Note

Please read these operating instructions before unpacking and putting the unit into operation. Follow the instructions precisely as described herein.

The devices are only to be used, maintained and serviced by persons familiar with these operating instructions and in accordance with local regulations applying to Health & Safety and prevention of accidents.

When used in machines, the measuring unit should be used only when the machines fulfil the EC-machine guidelines.

When using the OEM designs (OPT - 0), the electromagnetic compatibility in the plant must be demonstrated. The sensors themselves are not subjected to any testing of this type.

3. Instrument Inspection

All Instruments are inspected before shipping and sent out in perfect condition. Should damage to a device be visible, we recommend a thorough inspection of the delivery packaging. In case of damage, please inform your parcel service / forwarding agent immediately, since they are responsible for damages during transit.

Scope of delivery:

The standard delivery includes:

- Optical Level Sensor model: OPT
- Operating instructions

4. Regulation Use

Any use of the Optical Level Sensor, model: OPT, which exceeds the manufacturers specification may invalidate its warranty. Therefore any resulting damage is not the responsibility of the manufacturer. The user assumes all risk for such usage.

5. Operating Principle

The optical level sensors of model OPT have been developed for monitoring **transparent** liquids. Due to the very small dimensions, very slight switching hysteresis and high repeatability, the instruments are also suited for service in small vessels. The optical sensor is situated in a robust housing. It comprises a plastic hollow hemisphere, in which the infrared diode is fitted as a transmitter and a semiconductor as a receiver. When the sensor is not wetted by liquid, the infrared light is reflected fully from the surface of the hemisphere to the receiver. As soon as the sensor is covered with liquid, the refractive index on the boundary layer changes and most of the light escapes into the liquid. Less light then reaches the receiver, which allows switching to take place. The level probe should not be fitted with the sensor pointing downwards, as errors can occur due to drops of liquid sticking to it.

6. Mechanical Connection

Before installation:

Make sure that the maximum operating pressures and temperatures allowed for this device are not exceeded (see 8. Technical Information).

Avoid mounting the Optical Level Sensor vertically downward from the top of the container cover. In this position, drops accumulating on the optical sensor can cause the sensor to report an apparent, false, simulated level (switching point reached).

Recommended mounting positions:

- On the side wall of the tank
- Vertically upward on the bottom of the tank

6.1. Process Connection M14 with Nut (OPT-..10)

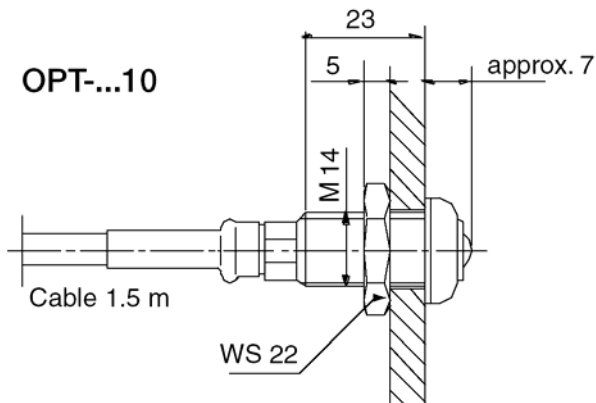

Hole in the bottom of the tank:
 \varnothing 15 mm

The device is sealed with the
 supplied O-ring.

6.2. Process Connection G 1/2 (OPT-..22)

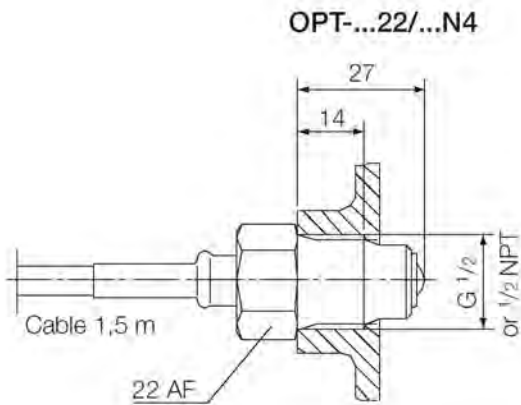

Seal the device in the side of the
 container with Teflon tape or similar
 sealant.

7. Electrical Connection

7.1. General Information



Attention! Make sure that the voltage values of your system correspond with the voltage values of the measuring unit.



Make sure that the supply wires are de-energised.

7.2. Terminal Connection Diagrams

OPT-4...

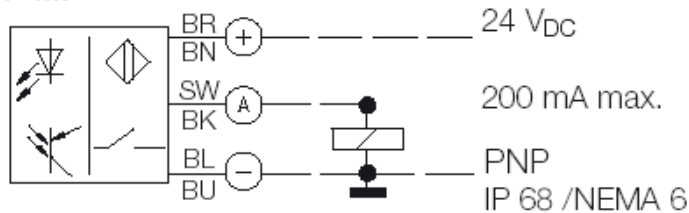

OPT-5...

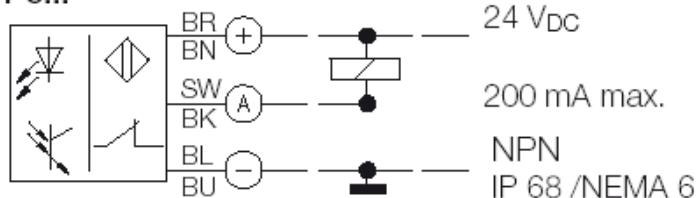

OPT-6...

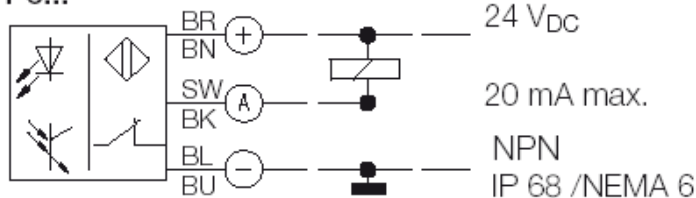

OPT-0... (OEM version)

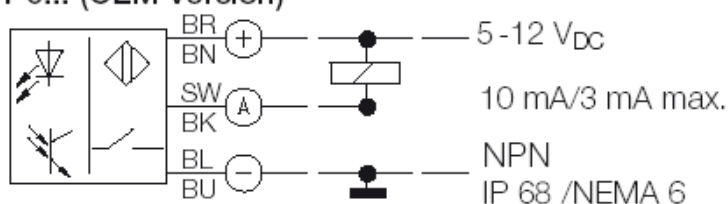

Connection example OPT-4xxx with pulse relay MSR-010/MSR-020

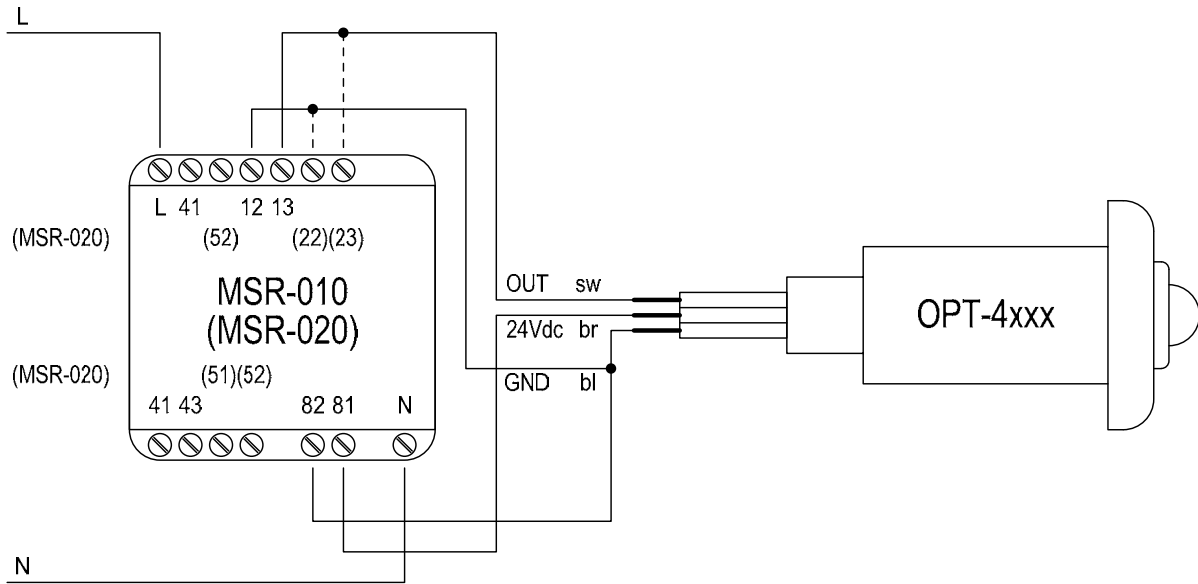

Connection example OPT-5xxx with pulse relay MSR-010/MSR-020 and external pullup resistor 4700 Ohm

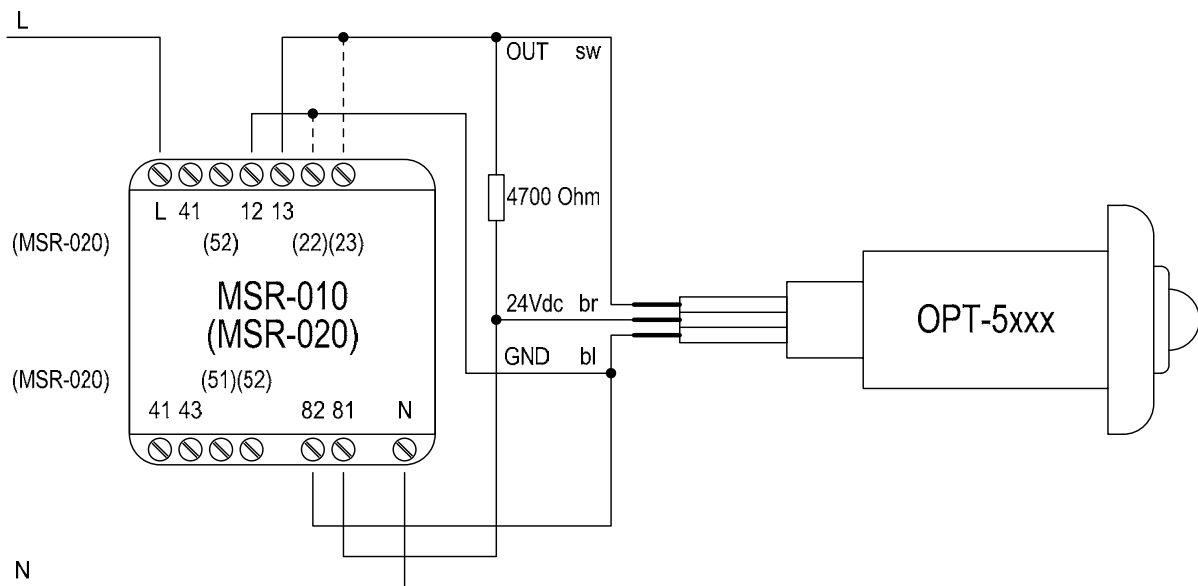

8. Technical Information

Operating temperature: -20 to +80 °C
Operating pressure: max. 10 bar
Protection: IP 68

Material:

Housing: OPT-__1__ : Polypropylene
OPT-__2__ : St. steel (1.4301)
Sensor: Polysulfone
Cable: Polyurethane 1.5 m, Ø 4.5 mm
O-ring: OPT-__2__ : FPM
Hexagon nut: OPT-__10 : Polyamide
Flat gasket: OPT-__10 : FPM

Electrical data

Repeatability: ±1 mm
Hysteresis: ±1 mm
Response time: 50 µsec (with rising level)
1 sec (with falling level)
depending on viscosity

OPT-0 (OEM-version, without CE-marking)

Power supply: 5-12 VDC ± 5 %
Current input: 15 mA typ. at V_{DC} (without load)
Output: NPN, open collector,
function N/O contact (WET on)
Current output: 10 mA max. at 25 °C
3 mA max. at 80 °C

OPT-4

Power supply: 24 VDC ± 15 %
Current input: 17 mA typ. at 24 V_{DC} (without load)
Output: PNP, Open Collector,
function N/O contact (WET on)
Current output: 200 mA, short-circuit-proof

OPT-5

Power supply: 24 VDC ± 15 %
Current input: 17 mA typ. at 24 V_{DC} (without load)
Output: NPN, Open Collector,
function N/C contact (DRY on)
Current output: 200 mA, short-circuit-proof

OPT-6

Power supply: 24 VDC ± 15 %
Current input: 17 mA typ. at 24 V_{DC} (without load)
Output: NPN, Open Collector,
function N/O contact (WET on)
Current output: 20 mA max., not short-circuit-proof

9. Order Codes

Example: **OPT-0 1 10**

Model	Version	Housing material	Connection female thread
OPT-	0 = 5-12 V _{DC} , NPN, OEM (without CE) 4 = 24 V _{DC} ± 15 %, PNP 5 = 24 V _{DC} ± 15 %, NPN 6 = 24 V _{DC} ± 15 %, NPN	1 = Polypropylene 2 = Stainless steel	10 = M14 with nut 22 = G 1/2 N4 = 1/2 NPT
MSR-010	Contact protection relay for OPT-4 and OPT-5, 230 V _{AC}		

10. Dimensions

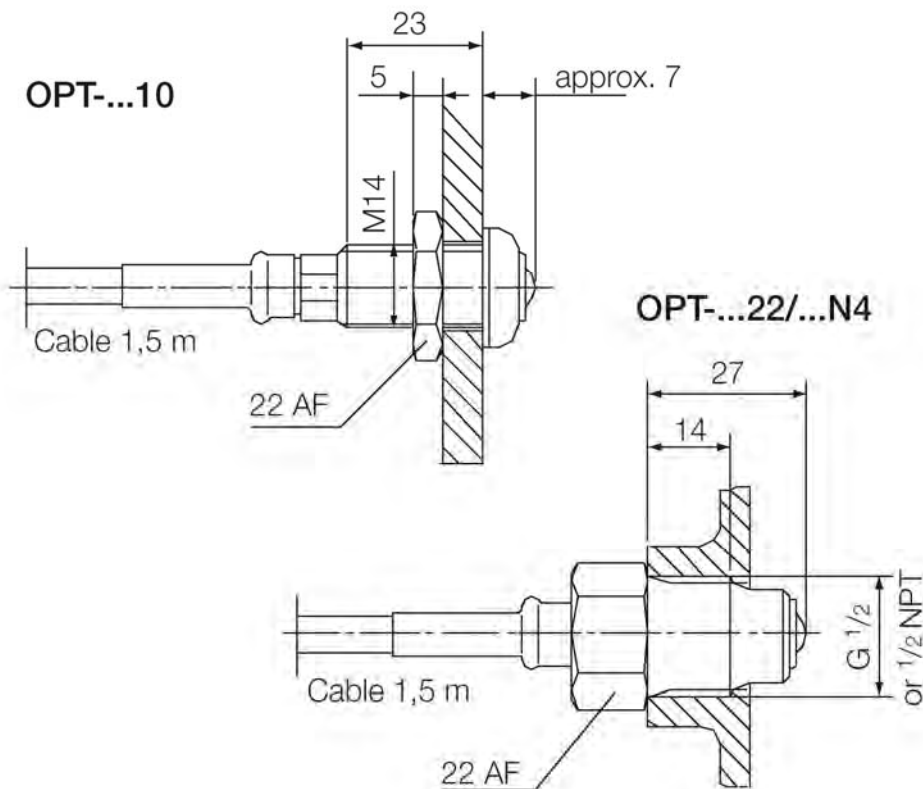

11. EU Declaration of Conformance

We, KOBOLD Messring GmbH, Hofheim-Ts, Germany, declare under our sole responsibility that the product:

Optical Level Sensor model: OPT -4..., OPT -5... and OPT-6

to which this declaration relates is in conformity with the standards noted below:

EN 61000-6-2:2005

Electromagnetic compatibility (EMC) - Part 6-2: Generic standards - Immunity for industrial environments

EN 61000-4-4:2013

Electromagnetic compatibility (EMC) - Part 4-4: Testing and measurement techniques - Electrical fast transient/burst immunity test

EN 61000-4-2:2009

Electromagnetic compatibility (EMC) - Part 4-2: Testing and measurement techniques - Electrostatic discharge immunity test

EN 61000-6-3:2011

Electromagnetic compatibility (EMC) - Part 6-3: Generic standards - Emission standard for residential, commercial and light-industrial environments

Also in conformance with the specifications in the following EEC directives:

2014/30/EU
2011/65/EU

EMC Directive
RoHS (category 9)

Hofheim, 27. April 2016



H. Peters
General Manager



M. Wenzel
Proxy Holder