

Operating Instructions for Vibrating Level Switches

Model: NVI



Order from: **C A Briggs Company**
622 Mary Street; Suite 101; Warminster, PA 18974
Phone: 267-673-8117 - Fax: 267-673-8118
Sales@cabriggs.com - www.cabriggs.com

1. Contents

1. Contents.....	2
2. Note	3
3. Instrument Inspection.....	3
4. Regulation Use.....	3
5. Operating Principle.....	4
6. Mechanical Connection.....	4
7. Electrical Connection	7
7.1 General.....	7
7.2 Operation Diagram	7
8. Commissioning.....	8
8.1 Density (Sensitivity) Adjustment (Switch A)	8
8.2 High/Low Fail-Safe Mode (Switch C)	8
8.3 Time Delay (Switch B)	8
9. Technical Information.....	9
10. Derating Diagram	10
11. Order Codes	10
12. Maintenance	10
13. Storage	11
14. Guarantee	11
15. Dimensions	11
16. EU Declaration of Conformance.....	12

Manufactured and sold by:

Kobold Messring GmbH
Nordring 22-24
D-65719 Hofheim
Tel.: +49(0)6192-2990
Fax: +49(0)6192-23398
E-Mail: info.de@kobold.com
Internet: www.kobold.com

2. Note

Please read these operating instructions before unpacking and putting the unit into operation. Follow the instructions precisely as described herein.

The devices are only to be used, maintained and serviced by persons familiar with these operating instructions and in accordance with local regulations applying to Health & Safety and prevention of accidents.

When used in machines, the measuring unit should be used only when the machines fulfil the EC-machine guidelines.

3. Instrument Inspection

Instruments are inspected before shipping and sent out in perfect condition.

Should damage to a device be visible, we recommend a thorough inspection of the delivery packaging. In case of damage, please inform your parcel service / forwarding agent immediately, since they are responsible for damages during transit.

Scope of delivery:

The standard delivery includes:

- Vibrating Level Switch model NVI
- Operating Instructions

4. Regulation Use

Any use of the Vibrating Level Switch, model: NVI, which exceeds the manufacturers specification may invalidate its warranty. Therefore any resulting damage is not the responsibility of the manufacturer. The user assumes all risk for such usage.

5. Operating Principle

The KOBOLD NVI level switch is a mechanical system that is made to resonate by an electronic switching operation. When the probe is covered by a medium, the vibrations are damped. This change in the resonance frequency is converted to a switching signal by electronic means.

The combined vibrating switch can be used in powdery media and granular materials. The medium to be measured should have a density of at least 0.05 kg/dm³. The single rod design prevents deposit formation. The rod is self-cleaning, as the vibrations shake off the medium.

6. Mechanical Connection



Important! Handle the device with great care, especially the sensing probe. A larger impact on the sensing probe may ruin its resonance system. Probes exposed to falling material or mechanical loads should be protected.

- Prior to the installation, it is advised to test the switching function of the unit on a sample quantity of material and to set „Density“ switch according to the density of medium. (see 8. Commissioning)
- Screw in the device by its hexagon neck. After screwing tight the process connection, the housing can be rotated (max. 300 °), to adjust the cable glands to the required position. In some cases such as material caving or arching you will need to mount the vibration rod at a clearance from the desired limit.

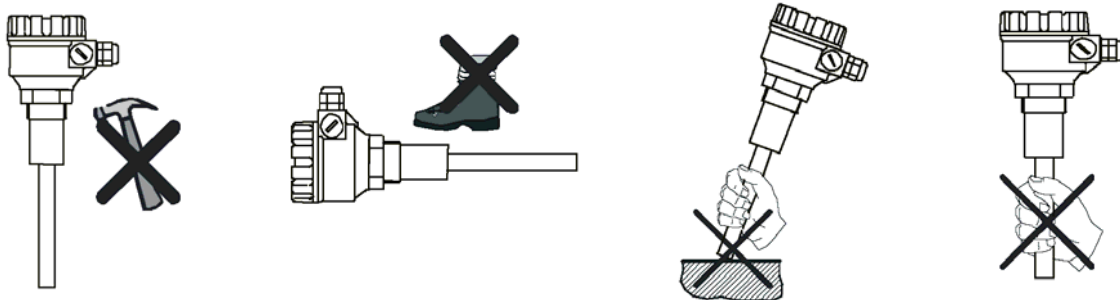

- The model NVI is not suggested to be used for low level detection in high density materials.

Max. switching

Min. switching

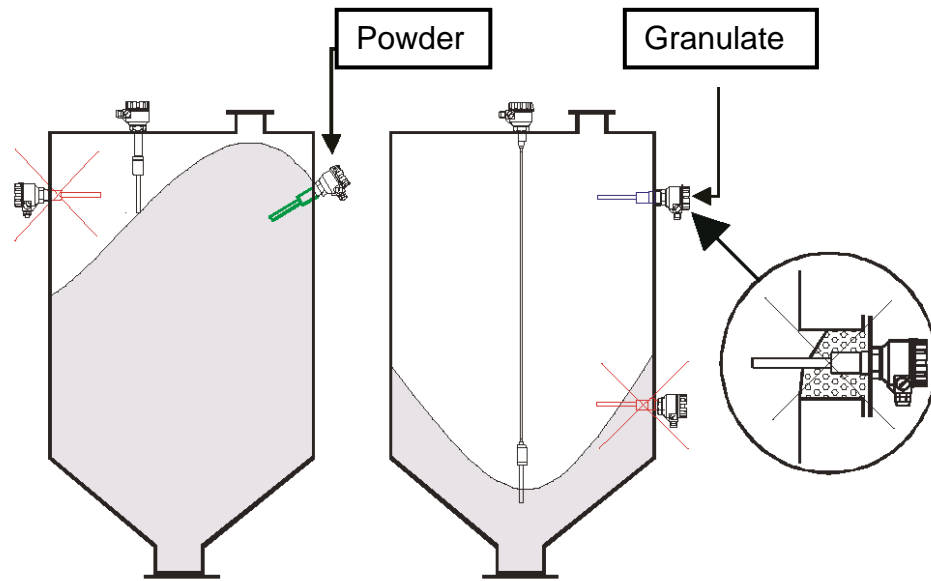

Limits for bending or pulling force and torque should be considered:

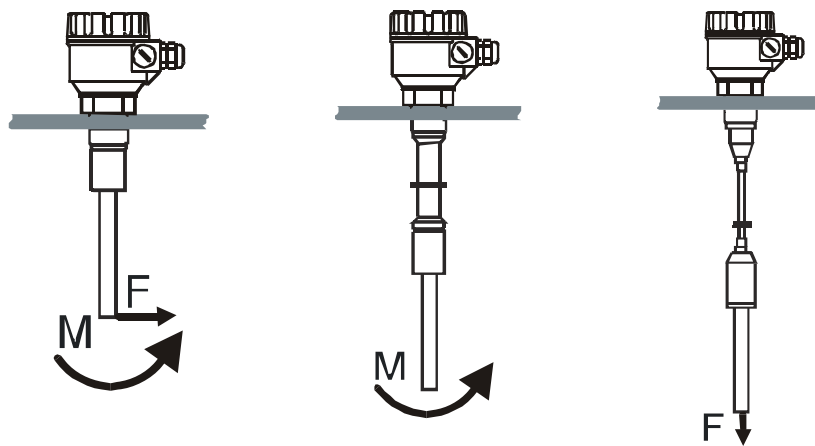

$F = 500 \text{ N}$
 $M = 100 \text{ Nm}$

$M = 100 \text{ Nm}$

$F = 45 \text{ kN}$

- Probes exposed to falling material or mechanical loads should be protected.

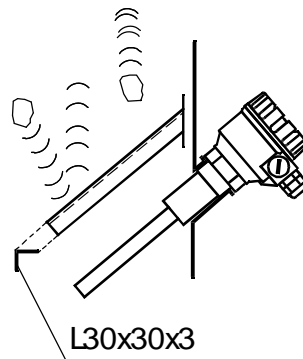

- When working with powdery bulk materials you should install the device at an inclination greater than the existing angle of repose, or even vertically to detect maximum level. This is necessary in order to prevent too much powder clinging to the vibration rod and hindering vibration and self-cleaning of the rod when the silo/tank is being emptied. Avoid mounting the device as shown in the diagram.

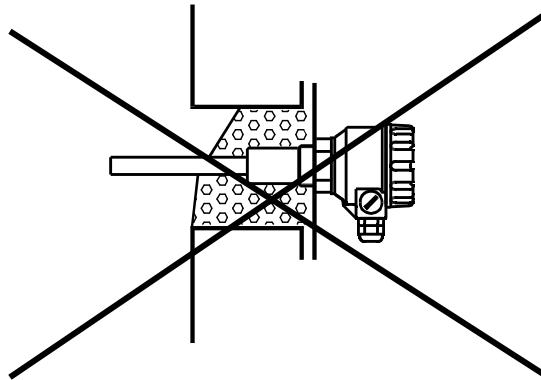

Use rubber shims for example to protect the device in bins/silos where large vibrations occur.

7. Electrical Connection

7.1 General



Attention! Check that the electrical power supply to the instrument complies with the operating data for the instrument.

AC = Switch rating acc. To EN60947-1

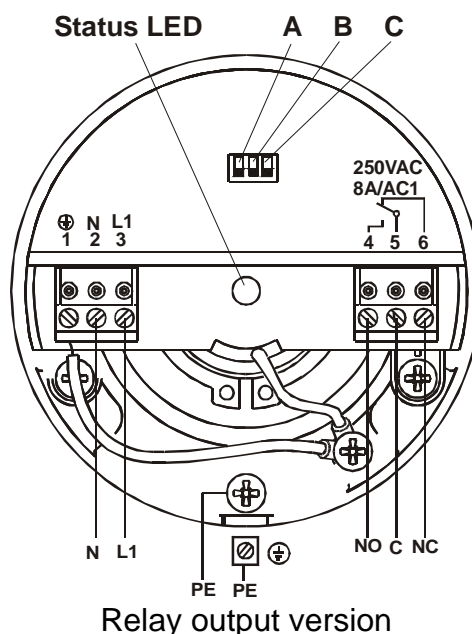

Attention! Incorrect wiring will lead to damage of the unit's electronics.

7.2 Operation Diagram

Power	Probe	Fail-safe mode	LED	RELAY
ON	NOT VIBRITING (COVERED)	LOW	GREEN	ENERGISED
		HIGH	RED	DE-ENERGISED
	VIBRITING (FREE)	LOW	RED	DE-ENERGISED
		HIGH	GREEN	ENERGISED
FAILS		LOW OR HIGH	NOT LIT	DE-ENERGISED

8. Commissioning

Unscrew the housing cover to access the terminals and setting switches. **Do not disconnect the wire from terminal connection point 1.** Ground the device at terminal PE or use the grounding screw on the device.

When you have properly connected the device, it is ready for operation. The LED lights up when the device is switched on.

8.1 Density (Sensitivity) Adjustment (Switch A)

The DIP-Switch DENSITY (switch A) needs to be set to suit the material density.

- LOW position, recommended for loose and light materials with **density** around and below 0.1 kg/dm^3 represents **low energy** and **amplitude** of vibration as well as **great sensitivity** of detection.
- HIGH position, recommended for (thick and heavy) materials with **density** over 0.1 kg/dm^3 represents vibration with **high energy and amplitude** and **small sensitivity** of detection.

8.2 High/Low Fail-Safe Mode (Switch C)

De-energised status of the relay is preferred to be used for fail-safe alarm, thus a power breakdown will be considered as alarm (see 7.2 Operation Diagram)

8.3 Time Delay (Switch B)

Though the density of the medium is within the specific range, the device may not detect if the internal friction of the medium is too low. Choose a switch delay (switch B) to suit process requirements (standard response time, switch delay = 5 s; short response time, switch delay = 2 s).





Note: The device can be damaged by electrostatic discharge (e.s.d.) from the DIP switch. To prevent such damage, the general precautions must be strictly observed.

9. Technical Information

Probe length:	207 mm (standard) pipe extended version: up to 3 m cable extended version, PE coated: up to 20 m
Process connection:	G 1 1/2 or 1 1/2" NPT
Housing material:	aluminium, powder coated
Material for wetted parts:	1.4571 (AISI316Ti) for vibrating probe PE cover for cable
Sensor surface:	bright
Medium temperature:	-30 °C...+110 °C standard probe -30 °C...+80 °C (NVI-5) -30 °C...+160 °C high temperature
Ambient temperature:	-30 °C...+60 °C
Maximum pressure:	25 bar (NVI-1/2/3/4) 6 bar (NVI-5)
Minimum density of medium:	0.05 kg/l
Max. grain size:	10 mm

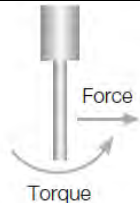
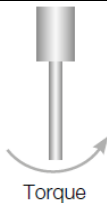
Max load:

Version	Standard	Pipe extended	Cable extended
High limit switch	Side mounted	Top mounted	Top mounted
Low limit switch	Side or bottom mounted		
Loadability			
Force	500 N	-	45 kN
Torque	100 N	100 Nm	-

Switching delay (selectable):	1.8 s or 5 ± 1.5 s
(selectable)	with covered rod 2 s or 5 ± 1.5 s rod swings freely
Output:	changeover contact 250 V _{AC} / 8 A
Power supply:	20...255 V _{AC/DC} ; ≤ 2.5 VA/2 W
Electrical connection:	2xM20x1.5
Protection:	IP 67
Weight:	approx. 1.9 kg (NVI-1/2) approx. 3.3 kg (NVI-3/4) approx. 2.5 kg (NVI-5)

10. Derating Diagram

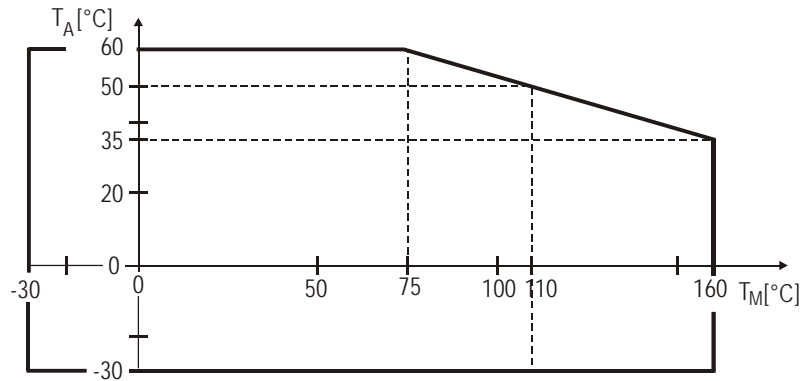

Ambient temperature (T_A) versus medium temperature (T_M)

11. Order Codes

Example: NVI-1 305 R

Model	Version	Power supply	Connection
NVI-	1 = standard probe	305 = 20...255 V _{AC/DC}	R = G 1 ½ N = 1 ½" NPT
	2 = standard probe, high-temperature		
	3* = pipe extended		
	4* = pipe extended, high temperature		
	5* = cable extended		

* Mention desired length in clear text (in mm).

12. Maintenance

Series NVI devices require no regular maintenance. You may need to remove product stuck to the vibrating section and clean the vibrating section every now and then. Handle the vibrating section of the vibration rod **with great care** to avoid any damage.

The manufacturer will carry out all repairs within and beyond the guarantee period. Clean or disinfect all parts before returning them for repair.

13. Storage

Ambient temperature: -35 up to +60 °C
 Relative humidity: max. 98 %

14. Guarantee

All guarantee repair work will be carried out in the manufacturer's workshop. The costs of demounting, installation, and transportation shall be borne by the purchaser.

All rights to claims under guarantee for faults caused by incorrect installation, rupture, improper handling or force majeure will not be honoured.

15. Dimensions

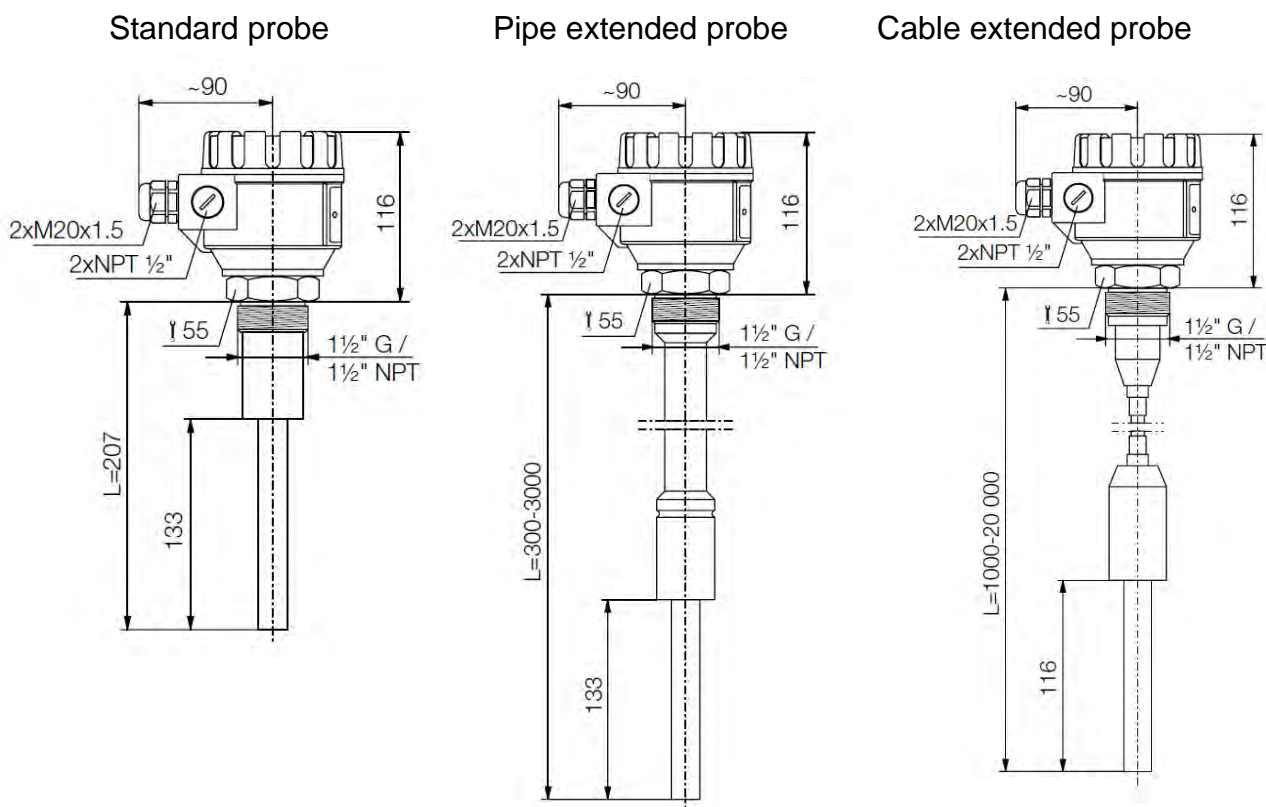

16. EU Declaration of Conformance

We, Kobold Messring GmbH, Hofheim-Ts, Germany, declare under our sole responsibility that the product:

Vibrating Level Switches Model: NVI

to which this declaration relates is in conformity with the standards noted below:

EN 61010-1:2011 Safety requirements for electrical equipment for measurement, control and laboratory use – Part 1: General requirements

EN 61326-1:2013 Electrical equipment for measurement, control and laboratory use - EMC requirements – Part 1: General requirements

EN 61326-2-3:2013 Electrical equipment for measurement, control and laboratory use - EMC requirements - Part 2-3: Particular requirements - Test configuration, operational conditions and performance criteria for transducers with integrated or remote signal conditioning

Also the following EU guidelines are fulfilled:

2014/30/EU **EMC Directive**
2011/65/EU **RoHS**

Furthermore for equipment with supply voltage < 48 V:

2014/35/EU **Low Voltage Directive**

Hofheim, 11. May 2017

H. Peters
General Manager

M. Wenzel
Proxy Holder