

# Operating Instructions

for

## Level Switches

**Model: NV**



Order from: **C A Briggs Company**  
622 Mary Street; Suite 101; Warminster, PA 18974  
Phone: 267-673-8117 - Fax: 267-673-8118  
[Sales@cabriggs.com](mailto:Sales@cabriggs.com) - [www.cabriggs.com](http://www.cabriggs.com)

## 1. Contents

---

1. Contents .....	2
2. Note .....	3
3. Instrument Inspection .....	3
4. Regulation Use .....	3
5. Operating Principle .....	4
6. Mechanical Connection .....	4
7. Electrical Connection .....	5
8. Commissioning .....	5
9. Maintenance .....	5
10. Technical Information .....	6
11. Order Codes .....	7
12. Dimensions .....	7
13. EU Declaration of Conformance .....	8

**Manufactured and Marketed by:** KOBOLD Instruments Inc.  
1801 Parkway View Drive  
Pittsburgh PA 15205-1422  
Tel.: 412-788-2830  
Fax: 412-788-4980  
E-Mail: [info@koboldusa.com](mailto:info@koboldusa.com)  
Internet: [www.koboldusa.com](http://www.koboldusa.com)

## 2. Note

---

Please read these operating instructions before unpacking and putting the unit into operation. Follow the instructions precisely as described herein.

The devices are only to be used, maintained and serviced by persons familiar with these operating instructions and in accordance with local regulations applying to Health & Safety and prevention of accidents.

When used in machines, the measuring unit should be used only when the machines fulfil the EC-machine guidelines.

## 3. Instrument Inspection

---

Instruments are inspected before shipping and sent out in perfect condition.

Should damage to a device be visible, we recommend a thorough inspection of the delivery packaging. In case of damage, please inform your parcel service / forwarding agent immediately, since they are responsible for damages during transit.

### **Scope of delivery:**

The standard delivery includes:

- Level Switch            model: NV
- Operating Instructions

## 4. Regulation Use

---

Any use of the Level Switch, model: NV, which exceeds the manufacturer's specification may invalidate its warranty. Therefore, any resulting damage is not the responsibility of the manufacturer. The user assumes all risk for such usage.

The units of type NV are intended to be used for monitoring of liquid-level measurement. Only use liquids which are chemically inert to the materials used in the construction of these devices.

By using at least two level monitors, where one is used for minimum level and the other for max. level, liquid level control may be accomplished.

## 5. Operating Principle

---

The Kobold Level Switch model NV is a reasonably-priced compact instrument for monitoring levels. A stainless steel cylindrical float attached to one end of a balance arm moves up and down with the liquid level.

The motion of the float is transferred to a permanent magnet fitted at the other end of the balance arm. The permanent magnet switches a reed contact that is fitted in a sliding tube outside the medium. The tube is set as a N/O contact at the factory, that is, the contact closes when the level rises. The switching function is reversed by moving the tube. The instruments are delivered in standard sleeves for side installation. PTFE tape is used to seal the switch.

## 6. Mechanical Connection

---

The float switch is to be attached in such a way that the float can move freely over its entire range and must not come in contact with the walls, bottom, or cover of the container. Positions, where turbulence may be encountered, due to agitators or intake valves, are unsuitable for proper operation.

The container should not have freely moving solids or ferrite particles, since these will deposit on float magnet- resulting in disturbance in switching process. If the liquid contains sediments or suspended materials, special care must be exercised in order to keep these materials away from the float system.

The switch should be attached to the system while keeping in mind the need for easy access for installation and maintenance.

- Ensure that the permitted max. operational pressure and temperature limits are not exceeded.
- Make sure that no remains of packing material exist inside the unit.
- The installation position must be horizontal.
- If possible, examine all the connection joints for proper sealing, just after mechanical installation.

---

## 7. Electrical Connection

---

- Make sure that the electric supply lines are not active.
- Connect the cable with your power supply.
- The contact box is made of fibreglass reinforced plastic. This material provides protective insulation according to VDI 0720 class II; a separate protection conductor is not required.

Connection scheme

After connections are made to the desired external devices, the unit is ready for operation.

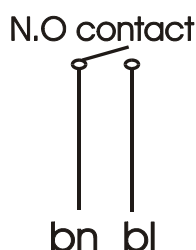

---

## 8. Commissioning

---

### Readjustment of switching unit

For the adjustment of switching unit, the locking disk on the upper part of housing must be loosened and the switching unit repositioned. To assist the adjustment procedure, a blue (white) or red arrow is provided on the switching unit. The leading edge of locking disk serves as adjustment mark.

#### **N.O. contact:**

The switching unit is to be set within the range of red arrow.  
The contact closes on increasing liquid-level.

#### **N.C. contact:**

The switching unit is to be set within the range of blue (white) arrow.  
The contact opens on increasing liquid-level.

---

## 9. Maintenance

---

As long as the medium to be measured is not contaminated, the device NV is maintenance-free. In particular, pay attention to ferrite particles in the medium, which tend to settle on the magnet, and can lead to problems. Larger dirt particles can cause seizure of the horizontal beam. Depending upon the degree of pollution of your medium, we recommend checking the device(s) after regular intervals.

## 10. Technical Information

---

### Specifications

**Max. Temperature:** 230 °F  
**Max. Pressure:** 232 PSIG  
**Fitting:** 3/4" NPT

### Materials

**Housing:** Brass or 304 SS  
**Float:** 304 SS  
**Plate Spring:** 304 SS  
**Sleeve:** Brass or 304 SS  
**Switch Housing:** Polyamide  
**Cable:** 2-wire with PVC Jacket  
**O-Ring**  
    **Brass Model:** NBR  
    **SS Model:** FKM

### Minimum Fluid Density

**1" Float Option:** 0.8 S.G.  
**2" Float Option:** 0.7 S.G.

**Switch Contact:** SPST Reed Switch  
(N/O or N/C)

**Max. Contact Ratings:** 2A @ 20 VAC,  
0.18 @ 230 VAC  
Max. 40 W  
cCSAus Approval

**Cable Length:** 5 ft. Standard  
(10', 15', 21' Optional)

**Protection:** NEMA 4 / IP65

Average electrical switch contact life (MTTF):

at max. electrical load:  $10^5$  switching operations  
at half load (<10% max. load):  $5 \cdot 10^7$  switching operations  
at low load (<10V/<1mA):  $10^8$  switching operations

## 11. Order Codes

Example: NV-5201

Float Length	Brass Model	SS Model
1"	NV-5101	NV-5201
2"	NV-5103	NV-5203
Optional Cables (5' Standard)		
..EC10	10 foot Cable	
..EC15	15 foot Cable	
..EC21	21 foot Cable	

## 12. Dimensions

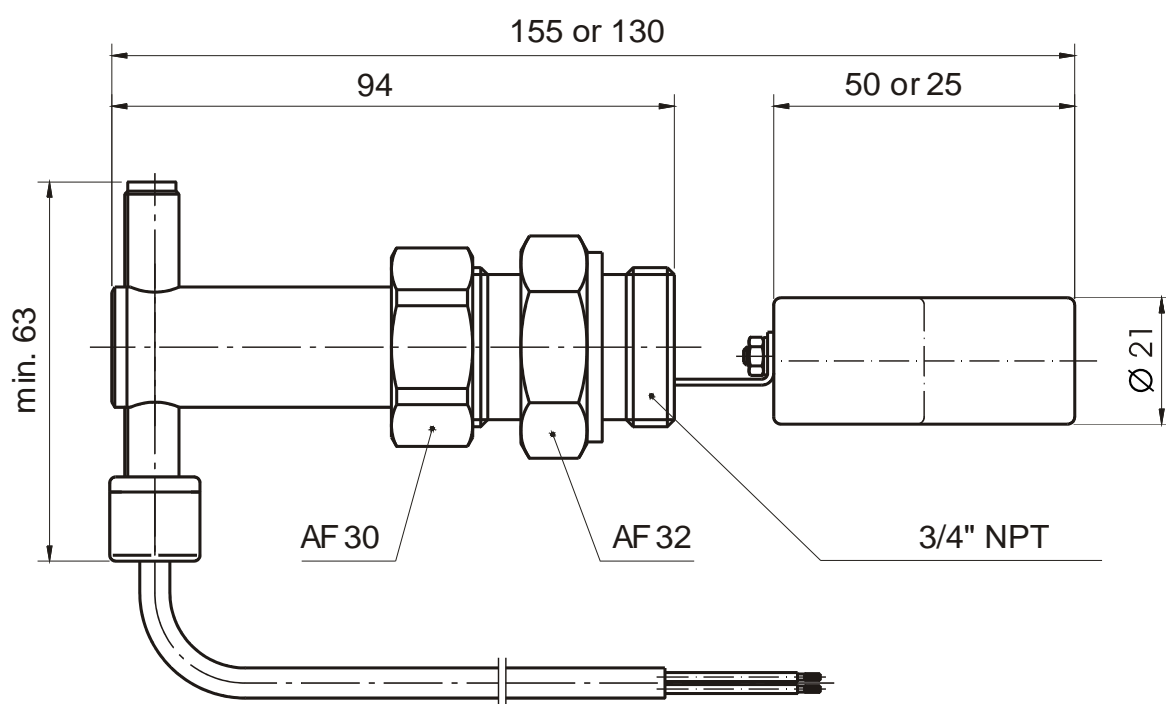

## 13. EU Declaration of Conformance

---

We, KOBOLD Messring GmbH, Hofheim-Ts, Germany, declare under our sole responsibility that the product:

**Level Monitor**            **model: NV...**

to which this declaration relates is in conformity with the standards noted below:

**EN 61010-1:2011**

Safety requirements for electrical equipment for measurement, control and laboratory use – Part 1: General requirements

**EN 60529:2014**

Protection through housing (IP-Code)

Also the following EC guidelines are fulfilled:

**2014/35/EU**            Low voltage guidelines

**2011/65/EU**            **RoHS**

**EN 50581:2012**      Technical documentation for the assessment of electrical and electronic products with respect to the restriction of hazardous substances

Hofheim, 12. Sept. 2017



H. Peters  
General Manager



M. Wenzel  
Proxy Holder