

NRF-2 and NRF-3
Capacitance Level & Temperature Transducer
INSTRUCTION MANUAL



measuring
•
monitoring
•
analyzing

NRF



Order from: **C A Briggs Company**
622 Mary Street; Suite 101; Warminster, PA 18974
Phone: 267-673-8117 - Fax: 267-673-8118
Sales@cabriggs.com - www.cabriggs.com

KOBOLD Instruments, Inc.
1801 Parkway View Drive
Pittsburgh, PA 15205
☎ Main Office:
1.800.998.1020
1.412.788.4890
✉ info@koboldusa.com
www.koboldusa.com



Instruction Manual
NRF-2 & NRF-3
Capacitance Level &
Temperature Transducer

Document No: NRF-	Issue Date: 10/2013
Software Rev. :	Rev. Date: 11/2013

DESCRIPTION

The KOBOLD series NRF-2 and NRF-3 combination level and temperature transmitters are truly a unique product. They are designed to measure level and temperature of conductive and non-conductive liquids in tanks. For level sensing, the probe measures the change in capacitance that occurs as level changes in the tank. For temperature sensing, the probe utilizes a Platinum resistive element.

The level calibration is accomplished via 4 push buttons and temperature calibration is accomplished via two pots, located on the transmitter.

Capacitance Level Transducer

Kobold two-wire NRF level transmitters are designed to measure either liquid or certain dry bulk media. The RF probes operate by applying a constant voltage to a metallic rod and monitoring the current that flows. This current is proportional to the capacitance from the metallic rod to a second electrode. Because the tank wall is the most convenient second electrode, the sensor monitors current to ground. The 12-30 VDC 4mA base current is the supply to the unit. The NRF monitors level change by converting movement of media UP or DOWN the probe into pulse wave form which is proportional to changes in level. The amplifier converts this pulse wave into 4 to 20 mA output signal. The conversion of level movement to an electrical signal is due to changes in electrical capacitance. The probe and a ground reference electrode, usually the metal tank wall, have a certain capacitance in air. As the medium displaces the air, a change occurs because of the difference in the dielectric constants of the medium and air.

The NRF comes complete with the transmitter mounted in an enclosure, fitting and probe (Fig. 1). Micro-processor based electronics are protected and potted within a metal housing. Calibration is made via four push buttons (Fig. 3) as explained later. Variety of options including Stainless or PVC housings, rigid or flexible probes (bare or jacketed), NPT, sanitary or flange connections are available.



Fig.1

INSTALLATION

UNPACKING

Unpack the instrument carefully. Inspect all components for damage. Report any damage to Kobold within 24 hours. Check the contents of the packing slip and report any discrepancies to Kobold.

INSTALLATION LOCATION

The Kobold NRF level sensor should be located for easy access for service, calibration and monitoring. Sensors

should not be exposed to ambient temperatures below -40°C (-40°F) or above +70°C (+160°F). Special precaution should be made to prevent exposure to corrosive atmosphere, excessive vibration, shock or physical damage. It is preferable that the NRF is not installed in proximity to high voltage wires or other sources of high electrical noise.

METAL WALLED TANKS

It is a common practice to use the metal tank wall as the reference electrode. In such cases, it is required that the probe housing makes a good electrical connection to the tank wall. If there is any doubt about this connection due to the use of PTFE thread tape, gaskets, paint, rust, or any other reason, a separate grounding wire should be installed between the probe and the tank housing. In case the probe housing is non-metallic, or if the connection fitting is non-metallic, a grounding wire must be connected from the tank to the G terminal on the transmitter.



This unit contains CMOS electronics which may be damaged by static electricity. Electronics may be accessed by removing the top cover of the enclosure (head). Do not remove the transmitter face plate (and touch the electronics). There are no serviceable parts.

NON-CONDUCTIVE TANKS /SILOS

With plastic, concrete, wood, or any other non-conductive walled vessels a reference electrode must be inserted into a tank.

Most commonly, this electrode will be in the form of a concentric, ground tube (i.e. stilling well, Fig. 2) or a metal rod installed in parallel with the probe. In all cases, a good electrical connection must be made between the ground reference electrode and the G terminal of the transmitter (or probe housing).

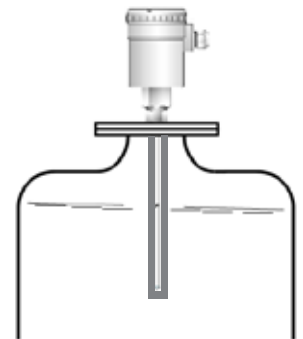

Fig. 2



When installing units with PTFE (or plastic) coats or cables, be careful not to damage the on. NPT threads have very sharp corners and PTFE (or plastic) can be easily cut. In acidic and/or conductive liquids damaged units may malfunction and the metal rods can corrode.

WIRING

All wiring between the power supply and the transmitter should be done with 18 AWG to 22 AWG shielded twisted pair. The connection is made at the terminal strip within the transmitter enclosure.



Units are designed to operate on the 12 to 30 VDC power only. Application of 110 VAC will destroy the instrument.

In order to calibrate the transmitter, you must use the loop current meter. It should read currents in the range of 1.00 to 25.00 mA, with a resolution of .01 mA. Using a meter of less resolution will somewhat reduce the calibration accuracy. There are two ways to calibrate the level and temperature transmitters, using 1 power supply or two power supplies.



This is highly recommended to calibrate both level and temperature transmitters with the same method.
IN ORDER TO CALIBRATE EACH TRANSMITTER, CONNECT BOTH TRANSMITTERS TO THE POWER SUPPLY.

NRF-2 LEVEL CALIBRATION

One-Power Supply Configuration

1. Make sure the power source is turned off.

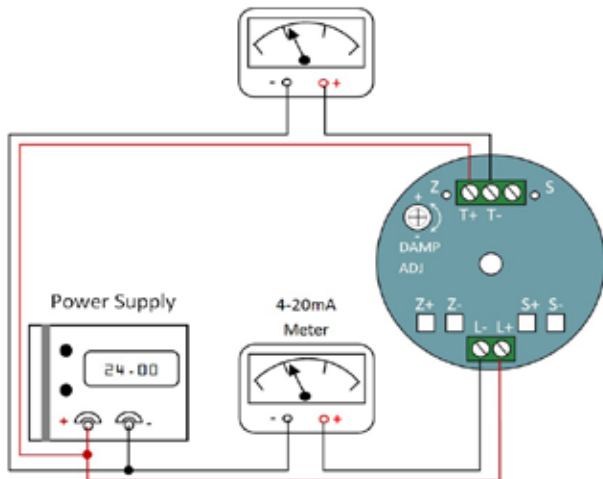

Fig. 3

2. Pull power supply wires through conduit connection.
3. Two pairs of wires are needed. Connect the positive supply wires to the (+) terminal, and the negative supply wires to the (-) terminal.



Leave shield unattached at transmitter.
Connect the shield to ground at the power source.

4. Replace the transmitter enclosure (head) cover until time to calibrate.
5. Connect positive supply wires to the positive terminal of the transmitters. See Fig. 3.
6. Connect the loop current meters in series with the negative supply wire of level and temperature transmitters as follows:
 - a. Negative transmitter wires to positive meters' terminal.
 - b. Negative meter terminals to negative power source terminal.
7. Turn ON the power. The meter may read anywhere on the scale at either end. This is normal until calibration has been completed. Proceed to the calibration Instructions.

Two-Power Supply Configuration

1. Make sure the two power sources are turned off.
2. Pull power supplies wires through conduit connection.
3. Connect the positive supply wires to the (+) terminal, and the negative supply wires to the (-) terminal.



Leave shield unattached at transmitter.
Connect the shield to ground at the power source.

4. Replace the transmitter enclosure (head) cover until time to calibrate.
5. Connect positive supply wires to the positive terminal of the transmitters. See Fig. 4.
6. Connect the loop current meters in series with the negative supply wire of level and temperature transmitters as follows:
 - a. Negative transmitter wires to positive meter terminals.
 - b. Negative meter terminals to negative power source terminals.
7. Turn ON the power supplies. The meter may read anywhere on the scale at either end. This is normal until calibration has been completed.

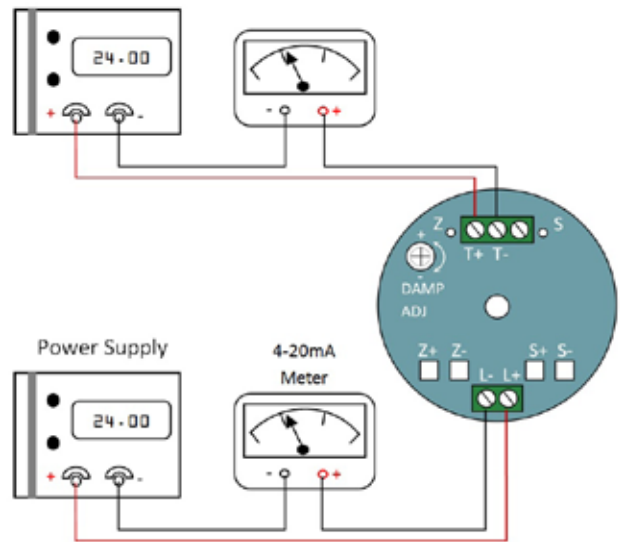

Fig. 4

NRF-3 LEVEL CALIBRATION

The calibration procedure for NRF-3 is the same as NRF-2, but in this case the temperature output may be directly connected to a controller or indicator. See Fig. 5.

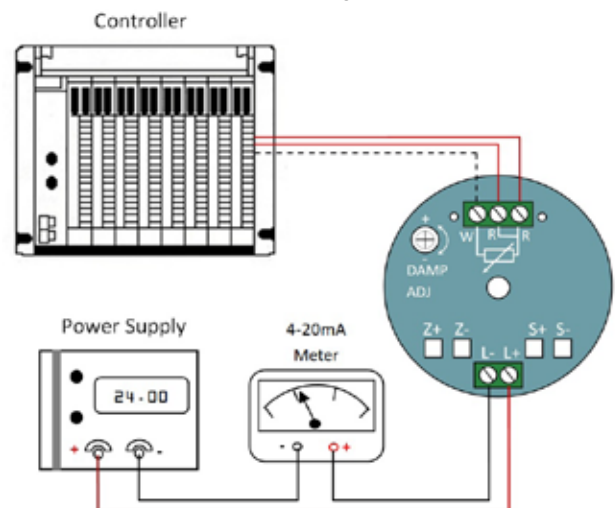

Fig. 5

TWO POINT CALIBRATION - LEVEL INCREASE

Three calibration procedures are described. Follow the one which fits your application. Note the following definitions used in the calibration procedures, referring to Fig 6.

L	The level of material which corresponds to 4.00 mA of loop current, i.e., the 0% level
L1	a material level higher than L
H1	a material level higher than L1, but less than H
H	The level of material in the vessel which correspond to 20.00 mA of loop current, i.e., the 100% level

To avoid the possibility of a “dead zone”, L must be at least two (2) inches above the end of the probe for conductive media and four (4) inches above for non-conductive media.

CALIBRATION L - H	When material in tank can be set to L (0%) and H (100%)
CALIBRATION L - H1	When material in tank can be set to L (0%) and H1 (less than 100%)
CALIBRATION L1 - H1	When material in tank can be set to L1 (greater than 0%) and H1 (less than 100%)

Calibration procedure H-L gives the most accurate results and is the recommended procedure in all cases.

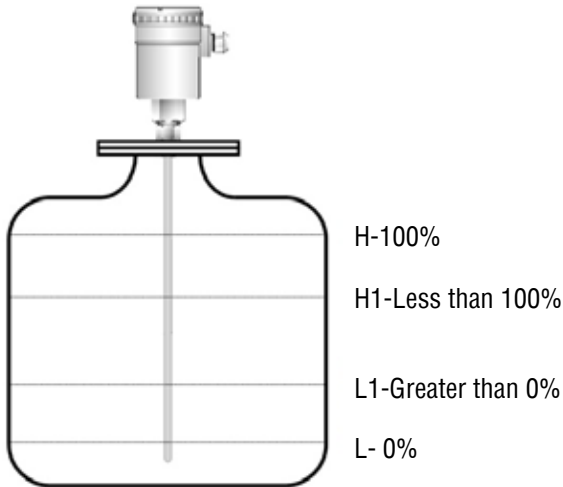

Fig. 6

OFFSET AND RESET FUNCTIONS

OFFSET and RESET functions (or values) are factory set. They may have to be changed by the customer in special cases only. Follow the procedures below.

There may seem to be a malfunction with the transmitter when the 4-20mA power loop is activated for the first time. The mA reading may be below 4mA or above 20mA and pressing the Z and S push buttons does not change the output.

Push button may have to be depressed for up to a minute before the value changes.

An OFFSET function may have to be performed. To re-OFFSET the transmitter, fill the level in the tank to cover the probe.

Press Z UP and S UP push buttons at the same time, then release in 1 or 2 seconds.

In very rare cases, a problem of calibration still may persist. This is because the values of the minimum and maximum are not properly distributed. The RESET function may have to be performed. To RESET the transmitter, simply press Z DW and S DW push buttons at the same time, then release the two push buttons after 1 or 2 seconds. Then re-OFFSET the transmitter as per instructions above. The transmitter will now show a default value close to 4mA.

When you RESET the transmitter, always perform the OFFSET after the RESET.

DAMPING ADJUST

This feature, primarily designed for agitated tanks and factory set at 0 sec. (max. CW, neg. direction) via a single turn pot, sets a time delay on the output signal.

The time delay range is 0-10 sec. approx. For non-agitated tanks a zero setting is fine. Increase the setting for agitated tanks by turning the pot CCW. This stabilizes the mA reading, but adds time delay. When performing calibration, always set pot to maximum CW direction (minimum time delay).

CALIBRATION PROCEDURE L-H

The ZERO. tank in L (Low) state. MUST always be calibrated first.

Turn the DAMP ADJ pot to max CW (neg.) direction.

1. Fill the tank to its H (100 %) level (with probe covered).
2. Depress UP or DW buttons on Z until meter reads 4.00mA. Do not change the zero controls from now on. If changed, the material will have to be returned to the H (100%) level.

If a 4.00mA value cannot be reached, then perform OFFSET AND RESET functions.

3. Fill the tank to the desired H (100%) level.



The loop current may not rise in proportion to the rising material level in tank. Instead it may rise more rapidly or more slowly than the material level. The span, S, UP or DW buttons may be used occasionally to maintain the loop current approximately proportional to the tank filling or just below the 20.00 mA reading.

4. After the tank has been emptied to H (100%), depress SPAN UP or DW buttons as required to obtain a meter reading of 20.00 mA. If 20.00 mA reading has been obtained, the calibration is complete.

If a 20.00mA value cannot be reached, then perform OFFSET AND RESET functions and re-start the calibration.

CALIBRATION PROCEDURE L-H1

The ZERO. tank in L (Low) state. MUST always be calibrated first.

Turn the DAMP ADJ pot to max CW (neg.) direction.

1. Fill the tank to its H (100 %) level (with probe covered).

- Depress UP or DW buttons on Z until meter reads 4.00mA. Do not change the zero controls from now on. If changed, the material will have to be returned to the H (100%) level.

$$mA = \frac{(24 - 12)}{(96 - 12)} \times 16 + 4 = 6.28$$

The correct loop current is 6.28mA.

If a 4.00mA value cannot be reached, then perform OFFSET AND RESET functions.

- Depress Z-UP or Z-DW buttons on ZERO until meter reads 8.00mA. Do not change the ZERO controls from now on. If changed, the material will have to be returned to the L (0%) level.

- Fill the tank to the highest point possible (under 100%), and record this level as H1. The most accurate calibration will be obtained with the greatest separation between L and H1.

If a 6.28mA value cannot be reached, then perform OFFSET AND RESET functions.

 The loop current may not rise in proportion to the lowering material level in tank. Instead it may rise more rapidly or more slowly than the material level. The SPAN, S-UP or S-DW buttons may be used occasionally to maintain the loop current approximately proportional to the tank emptying or just below the 20.00mA reading.

- Fill the tank to the lowest point possible (under 100%) and record this level as H1. The most accurate calibration will be obtained with the greatest separation between L and H1.

- To determine the loop current at L1 level use the following formula:

 The loop current may not rise in proportion to the rising material level in tank. Instead it may rise more rapidly or more slowly than the material level. The SPAN, S-UP or S-DW buttons may be used occasionally to maintain the loop current approximately proportional to the tank filling or just below the 20.00mA reading.

$$mA = \frac{(H1 - L)}{(H - L)} \times 16 + 4$$

Example: L = 12" (30.5 cm) from the bottom of the tank
H1 = 72" (183 cm) from the bottom of the tank
H = 96" (244 cm) from the bottom of the tank

- To determine the loop current at H1 level use the following formula :

$$mA = \frac{(72-12)}{(96 - 12)} \times 16 + 4 = 15.43$$

$$mA = \frac{(H1 - L)}{(H - L)} \times 16 + 4$$

Example: L = 12" (30.5 cm) from the bottom of the tank
H1 = 72" (183 cm) from the bottom of the tank
H = 96" (244 cm) from the bottom of the tank

The correct loop current is 15.43mA.

Depress SPAN S-UP or S-DW buttons as required to obtain a meter reading of 16.80mA. If 16.80mA reading has been obtained, the calibration is complete.

$$mA = \frac{(72-12)}{(96 - 12)} \times 16 + 4 = 15.43$$

The correct loop current is 15.43mA.

If a 16.80mA value cannot be reached, then perform OFFSET AND RESET functions and re-start the calibration.

Depress SPAN S-UP or S-DW buttons as required to obtain a meter reading of 15.43mA. If 15.43mA reading has been obtained, the calibration is complete.

CALIBRATION PROCEDURE L1-H1

The ZERO, tank in L (Low) state, MUST always be calibrated first.

If a 15.43mA value cannot be reached, then perform OFFSET AND RESET functions and re-start the calibration Loop.

Turn the DAMP ADJ pot to max CW (neg.) direction.

- Fill the tank to its L1, some point below 100% level and record this level as L1. See Fig. 4. To determine the loop current at L1 level use the following formula:

$$mA = \frac{(L1 - L)}{(H - L)} \times 16 + 4$$

Example: L = 12" (30.5 cm) from the bottom of the tank
L1 = 24" (61 cm) from the bottom of the tank
H = 96" (244 cm) from the bottom of the tank

NRF-2 TEMPERATURE TRANSDUCER

The temperature transmitter integrated with capacitive transmitter feature has linearized output to temperature for RTD. It is factory calibrated and designed for highest performance. A linearized output for RTD's is a unique performance feature of these transmitters.



The output of NRF-3 is a direct connection to RTD element inside the probe. Thus no calibration is required.

TEMPERATURE CALIBRATION

The temperature transmitter comes factory calibrated. If you need to re-calibrate the unit, you will require the following equipment :

- 9-36 VDC Power Supply with a milliamp indicator or a loop-powered calibrator.
- A temperature bath.
- A standard reference temperature sensor.
- Test leads

Two Point Calibration, Min. & Max. (Example : 0-100°C range)

1. Connect the temperature transmitter as per the wiring diagram for one-power supply configuration or two-power supply configuration. See Fig. 3 and 4, respectively.
2. Set the temperature bath to the minimum range of the transmitter, Ex.: 0°C = 4.00mA

3. With the temperature standard, verify the bath temperature and if required calculate the corresponding current output for the transmitter.
4. Immerse the probe in the temperature bath. Make sure the output stabilizes. With ZERO pot. adjust current output to 4.00mA or the corresponding current output.
5. Set the temperature bath to maximum range of the transmitter, Ex.: 100°C = 20.00mA
6. With the temperature standard, verify the bath temperature and if required calculate the corresponding current output for the transmitter.
7. Immerse the probe in the temperature bath. Make sure the output stabilizes. With the SPAN pot. adjust current output to 20.00mA or the corresponding current output.
8. Repeat steps 2 to 7 until required accuracy is reached. This step is necessary because of the small interaction between Zero and Span.

Single Point Calibration (Example : 0-100°C range)

In some cases, a single point calibration is sufficient especially when a process is at a fixed set point.

1. With a temperature standard, verify the correct process temperature and compare it to the sensor reading.
2. If the temperature reading is below the mid-point of the sensor range, use the ZERO pot. to obtain the correct reading.
3. If the temperature reading is above the mid-point of the sensor range, use the SPAN pot. to obtain the correct reading.

Specifications

Level Specifications

Accuracy :	± 1% of span (constant liquid dielectric)
Repeatability :	± 0.1 % of span
Max. Length :	12 feet

Electrical Specifications

Input Power :	12-30 VDC, polarity protected
Output :	4-20 mA, 2-wire
Max. Loop Res.:	700 Ohm @ 24 VDC
Calibration :	Via 4 push button switches non-interactive settings
Dampening Adjust :	0 - 30 Seconds
Temperature Range	
Process :	-100 ...350 °F
Ambient :	-58 ...140 °F

Temperature Specifications

Input :	Pt100, 3-wire, a = 0.00385, DIN EN 60751
Output :	4-20 mA loop powered, linear to temperature
Power Supply :	12-30 VDC, polarity protected
Long Term Drift :	± 0.05 % FS / year
Accuracy :	0.5 % FS
Span / Zero Adjustment :	20 turn potentiometer, ± 10 % for zero and span
Maximum Loop Resistance :	R _{max} = [V _{supply} - 9 VDC] / 20 mA
Open Circuit Detection :	Over-scale limit (27.0 mA) or Under-scale limit (2.2 mA)
Temperature Range	
Process :	-100 ...350 °F
Ambient :	-58 ...140 °F

Mechanical Specifications

Enclosures :	Polyamide NEMA 4, Stainless NEMA 4X or Aluminum NEMA 4X
Mounting Thread :	1/2" and 3/4" NPT, others available, consult factory
Fitting Mat'l:	316 Stainless Steel
Probe Mat'l:	Fully PFA clad 316 Stainless Steel
Maximum Pressure	
316 SS fitting :	500 PSIG @ 70°F 250 PSIG @ 300°F 100 PSIG @ 350°F
PTFE fitting :	14.7 PSIG max

- Information furnished by KOBOLD is believed to be accurate and reliable. However, no responsibility is assumed by KOBOLD for its use.
- Specifications subject to change without notice.