

**Operating Instructions
for
Dual-Magnet Float Switch**

Model: NGS



Order from: **C A Briggs Company**
622 Mary Street; Suite 101; Warminster, PA 18974
Phone: 267-673-8117 - Fax: 267-673-8118
Sales@cabriggs.com - www.cabriggs.com

1. Contents

1. Contents.....	2
2. Note	3
3. Instrument Inspection.....	3
4. Regulation Use.....	3
5. Operating Principle.....	4
6. ATEX-Marking.....	4
7. Indications for the Safe EX-use.....	4
8. Installation.....	5
9. Electrical Connection	6
10. Maintenance	6
11. Technical Information.....	7
12. Order Codes	8
13. Dimensions	8
13.1 Accessories	14
14. EU Declaration of Conformance.....	15
15. EU ATEX Declaration of Conformance	16
16. ATEX Certificate.....	17

Manufactured and sold by:

Kobold Messring GmbH
Nordring 22-24
D-65719 Hofheim
Tel.: +49 (0)6192-2990
Fax: +49(0)6192-23398
E-Mail: info.de@kobold.com
Internet: www.kobold.com

Edition: November 2016 (Revision 1)

2. Note

Please read these operating instructions before unpacking and putting the unit into operation. Follow the instructions precisely as described herein.

The devices are only to be used, maintained and serviced by persons familiar with these operating instructions and in accordance with local regulations applying to Health & Safety and prevention of accidents.

When used in machines, the measuring unit should be used only when the machines fulfil the EC-machine guidelines.

3. Instrument Inspection

All Instruments are inspected before shipping and sent out in perfect condition. Should damage to a device be visible, we recommend a thorough inspection of the delivery packaging. In case of damage, please inform your parcel service / forwarding agent immediately, since they are responsible for damages during transit.

Scope of delivery:

The standard delivery includes:

- Dual-Magnet Float Switchmodel: NGS
- Operating Instructions

4. Regulation Use

Any use of the Dual-Magnet Float Switches, model: NGS, which exceeds the manufacturer's specification, may invalidate its warranty. Therefore any resulting damage is not the responsibility of the manufacturer. The user assumes all risk for such usage.

5. Operating Principle

As the level rises and falls, the inclination of the float is changed causing a permanent magnet in the float to be deflected. This repels a rotatable opposing magnet. This forced snap-action-contact effect operates a microswitch with a plunger. Even very small changes in level can be switched in this way.

6. ATEX-Marking

The marking in ATEX for the Dual-Magnet Float Switch is as follows:

Ⓔ II 1/2 G Ex de mb IIC T6...T2 Ga/Gb

7. Indications for the Safe EX-use

- Ambient and medium temperature

Temperature class	Ambient temperature	Max. medium temperature
T6	-20 °C ... +60 °C	+80 °C
T5	-20 °C ... +70 °C	+95 °C
T4	-20 °C ... +80 °C	+130 °C
T3	-20 °C ... +80 °C	+200 °C
T2	-20 °C ... +80 °C	+250 °C

Except:

NGS-51*

T_{medium}: 0 °C...+100 °C

NGS-61*

T_{medium}: 0 °C...+200 °C

The applicable medium temperature range limited by next diagram:

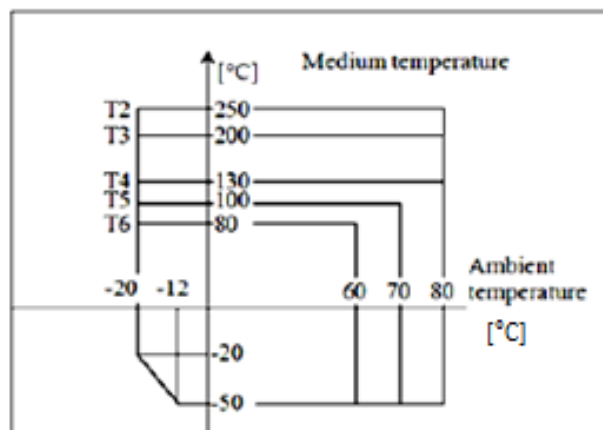

- For installation of version NGS-4 _ _ _Ex (with integrated cable) a suitable junctionbox shall be used.
- The NGS float switch shall be connected to the local EP circuit.
- The NGS float switch has to be provided in series with a 'T' marked 2.5 A circuit breaker as a short-circuit protection
- For Tamb >60 °C, a suitable cable shall be used.

Electrical parameters

For connection to an electrical circuit with following maximum values:

UN = 250 V	AC12	2.5 A
UN = 220 V	DC13	0.3 A

Cable: Cable diameter depends on the mounted cable gland,
Max. 5x2,5mm² cross section

Electric safety: Class I

Ingress protection:
See technical details

8. Installation

The float switch is to be installed in such a way that the float is able to move entirely free without touching the walls, the vessels top, or base. Avoid installation in turbulent positions: such as inlet valves and agitators.

Please also protect from suspended and ferrite particles that could gather around the float and disturb the switching process. When installing float switches in separate housings, suitable valves should be provided since dirty particles must be drained out from time to time.

For purposes of installation and maintenance, the switch should be installed in an easily accessible position.

The float switch must be installed with a connecting flange. A seal is enclosed separately. (Gasket Klingersil C 4500).

For corrosive media, the customer should install an appropriate seal compatible with the medium being used.

For vertical type NGS-23, the balance of the arms with differential length is provided by the shifting of counter weight to the proper point. Hysteresis of switching points can be adjusted on the vertical stick with fitting rings.

9. Electrical Connection



Attention! Make sure that the voltage values of your system correspond with the voltage values of the measuring unit.

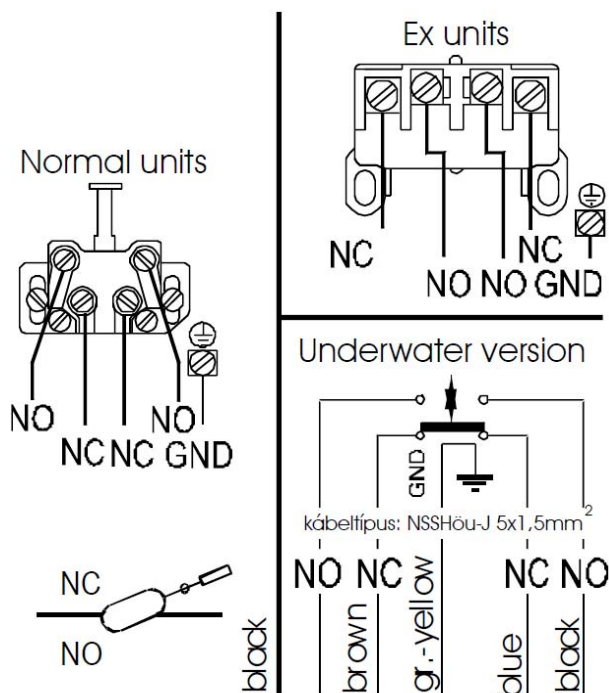

10. Maintenance

The measuring unit requires no regular maintenance. Sometimes cleaning of adhered materials is necessary. Repairs should only be carried out by the manufacturer.

11. Technical Information

NGS-_1, horizontal mounting, fixed differential

Nominal pressure: 25 bar
 Installation position: from side
 Differential: fixed, see diagram

NGS-_2, horizontal mounting, adjustable differential

Nominal pressure: 25 bar
 Installation position: from side
 Differential: adjustable

NGS-23, top mounting, adjustable differential

Nominal pressure: 16 bar
 Installation position: from above
 Differential: adjustable

General

Medium temperature: (see temperature diagram for Ex-version)

Type	Medium Temperature
NGS-2	-40...+250 °C
NGS-4	-20...+80 °C
NGS-5	0...+100 °C
NGS-6	0...+200 °C
NGS-7	0...+80 °C
NGS-8	0...+80 °C

Ambient temperature: -20 °C to +80 °C (Ex-version, see table below)

Min. medium density: > 0.7 kg/dm³ (see density table below)

Wetted parts: stainless steel 1.4571
 (NGS-5...: rubber, NGS-6...: silicon rubber)

Housing material: aluminium, colour coated

Flat gasket: Klingerit

Process connection: square flange, DIN Flange, 2" BSP or NPT

Switching element: 1 microswitch with 1 closing
 and 1 opening contact (NO and NC)

Switch rating: 250 V_{AC}/10 A; 220 V_{DC}/ 0.6 A

Ex: 250 V_{AC}/2.5 A; 220 V_{DC}/0.3 A

Electrical connection: M20x1.5 for NGS-2, NGS-5, NGS-6
 integrated cable for NGS-4, NGS-7, NGS-8

Protection: Standard version:
 NGS-2, NGS-5, NGS-6: IP 65

Submersible version:
 NGS-4, NGS-7, NGS-8: IP 68 (max. 20 m WC)

Weight: approx. 2.5 kg

Temperature Diagram for ATEX Version

Class	T6	T5	T4	T3	T2
Max. Process Temperature	80 °C	95 °C	130 °C	200 °C	250 °C
Ambient Temperature	-20...+60 °C	-20...+70 °C	-20...+80 °C	-20...+80 °C	-20...+80 °C

The applicable medium temperature range limited by this diagram.

Except: NGS-51* T_{medium}: 0 °C...+100 °C
 NGS-61* T_{medium}: 0 °C...+200 °C

Density Table

MINIMUM LIQUID DENSITY (kg/dm ³)				
ARM LENGTH (mm)	0 ... 100	200	300	1000 ... 3000
FLOAT (mm)				
52	0.7	0.8	0.85	–
64	0.7	0.8	0.8	–
124	–	–	–	0.7

12. Order Codes

See Datasheet

13. Dimensions

Fixed switch hysteresis, side installation

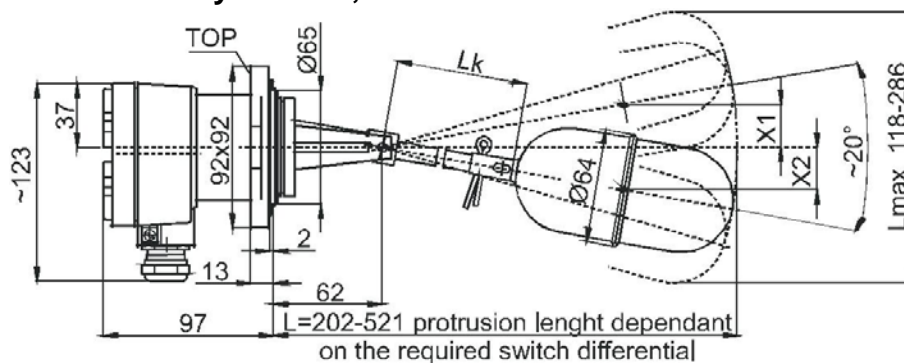

Switching data model NGS-21...

LK = linkage length	0	100	200	300
L = protrusion length	202	321	421	521
L _{max} = Total swing	118	180	234	286
X1 = high switch point	12	30	46	62
X2 = low switch point	12	30	46	62

Note: The data apply to water at 20 °C, tolerance ± 5 mm

Adjustable hysteresis, installation from above (NGS-23)

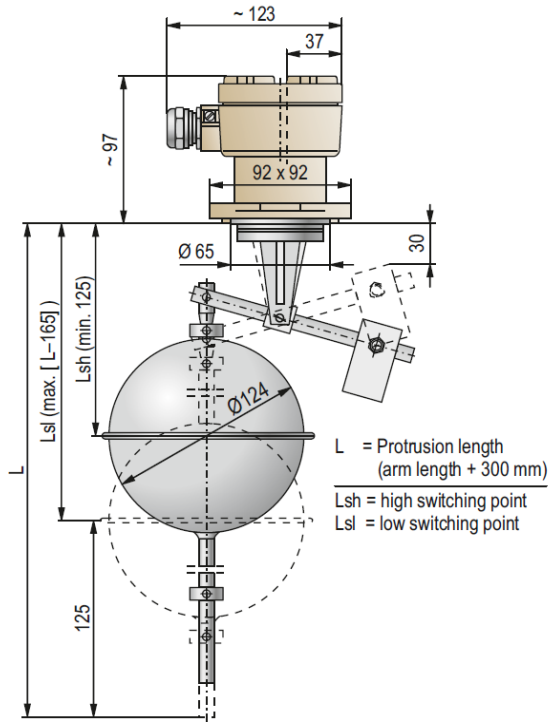

The hysteresis can be adjusted by positioning the rings on the rod. By positioning the counterweight the different rod lengths can be compensated.

Process connection: Threaded

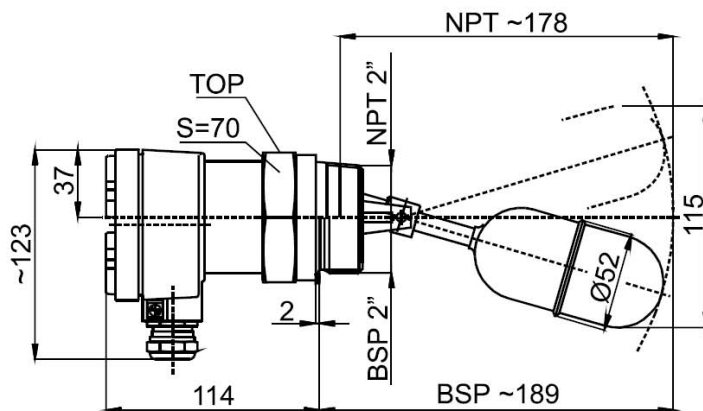

Square flange

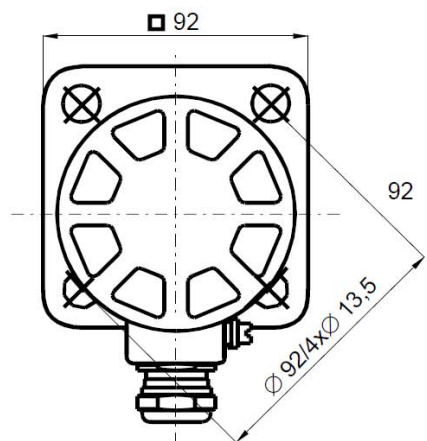

Process connection: Flanged

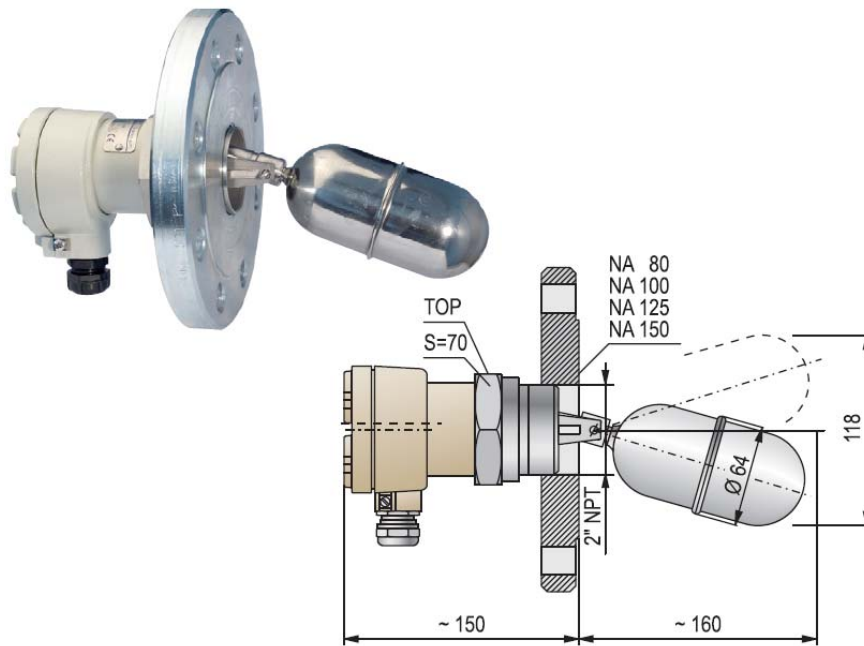

L arm, installation from above

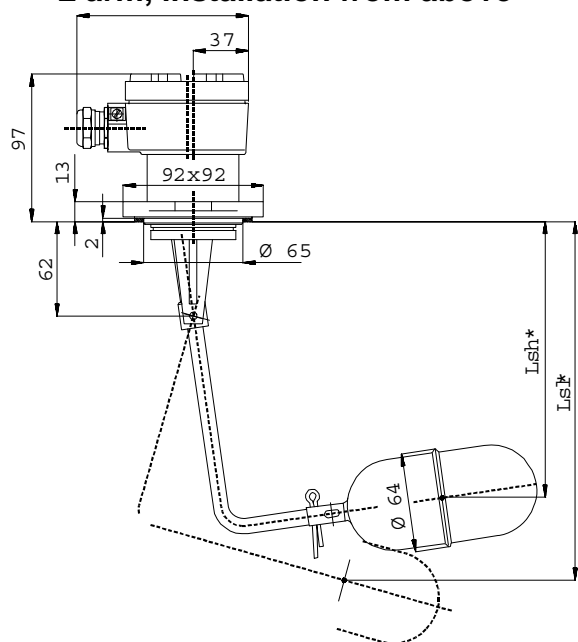

Lsh = high switch point
 Lsl = low switch point
 * only one value can be specified

Z arm, side installation

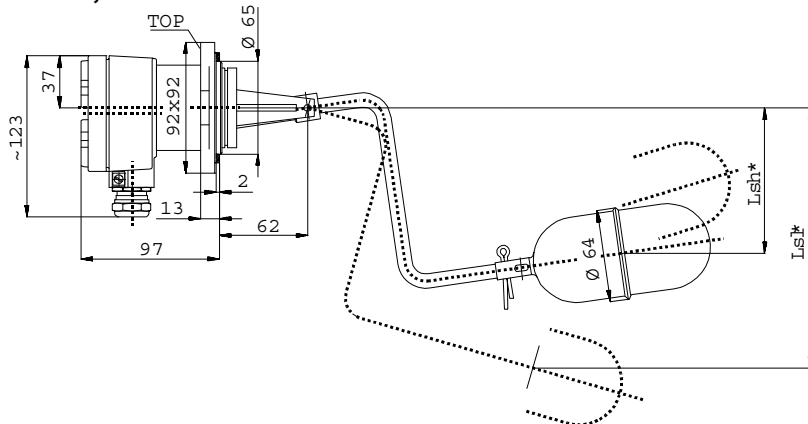

Lsh = high switch point
 Lsl = low switch point
 * only one value can be specified

Submersible Version (NGS-41)

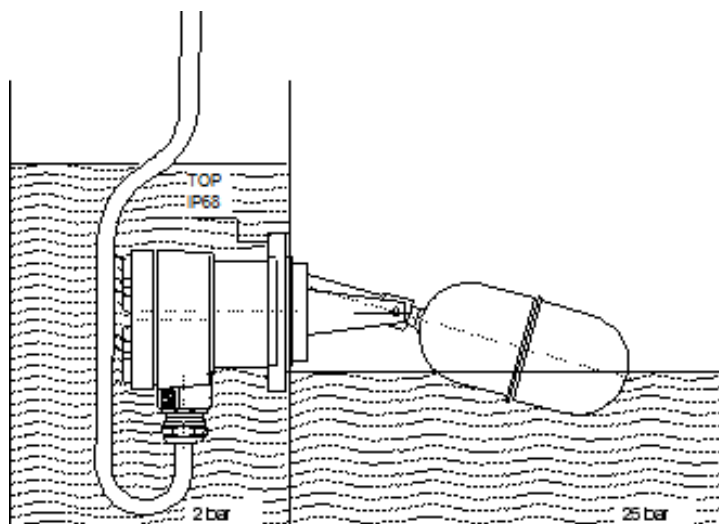

Fixed switch hysteresis, with protection sleeve

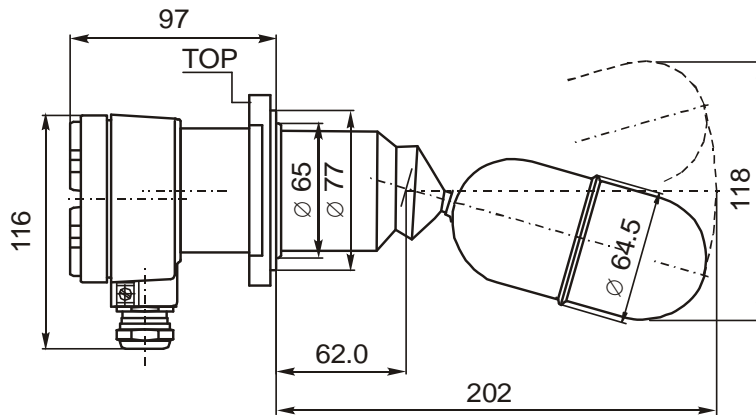

Adjustable switch hysteresis, side installation (NGS-22)

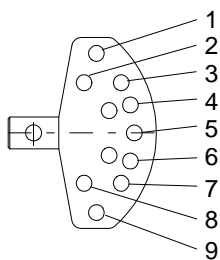
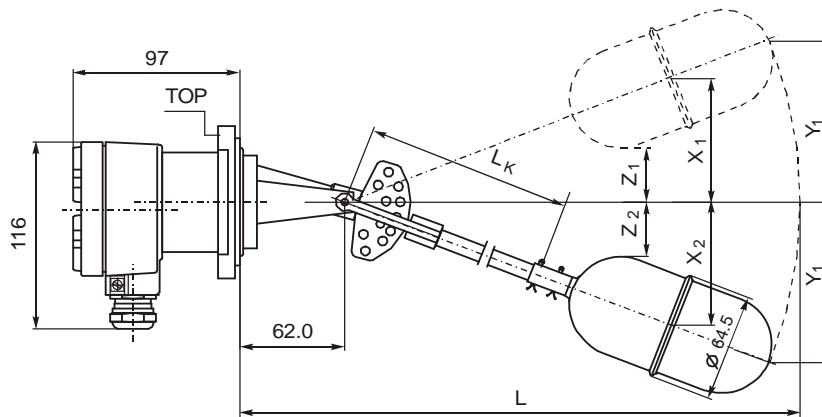

NGS-2200 NGS-2200Ex						NGS-2205 NGS-2205Ex					NGS-2206 NGS-2206Ex					NGS-2207 NGS-2207Ex				
L _k = 0						L _k = 100					L _k = 200					L _k = 300				
L = 268						L = 350					L = 450					L = 550				
Pos.	X ₁	X ₂	Diff S	Y ₁ (Z ₁)	Y ₂ (Z ₂)	X ₁	X ₂	Diff S	Y ₁ (Z ₂)	Y ₂ (Z ₂)	X ₁	X ₂	Diff S	Y ₁ (Z ₃)	Y ₂ (Z ₂)	X ₁	X ₂	Diff S	Y ₁ (Z ₄)	Y ₂ (Z ₂)
1-4	+87	+20	67	131	(13)	+129	+30	99	194	(19)	+171	+40	131	256	(25)	213	+50	163	319	(51)
1-5	+87	+12	75	131	44	+129	+18	111	194	87	+171	+24	147	256	36	213	+30	183	319	45
1-6	+87	-20	97	131	53	+129	-30	159	194	44	+171	-40	201	256	58	213	-50	263	319	72
1-7	+87	-42	129	131	84	+129	-62	191	194	92	+171	-82	253	256	121	213	-102	315	319	151
1-8	+87	-65	152	131	123	+129	-96	225	194	142	+171	-127	298	256	187	213	-158	371	319	233
1-9	+87	-89	176	131	131	+129	-132	261	194	194	+171	-175	316	256	256	213	-218	431	319	319
2-5	+80	+12	68	123	44	+118	+18	100	182	27	+156	+24	132	240	36	194	+30	164	299	45
2-6	+80	-20	100	123	53	+118	-30	148	182	44	+156	-40	196	240	58	194	-50	244	299	72
2-7	+80	-42	122	123	84	+118	-62	180	182	92	+156	-82	238	240	121	194	-102	296	299	151
2-8	+80	-65	145	123	123	+118	-96	214	182	142	+156	+127	283	240	187	194	-158	352	299	233
2-9	+80	-89	169	123	131	+118	-132	250	182	194	+156	-175	339	240	256	194	-218	402	299	319
3-5	+47	+12	35	84	44	+70	+18	52	104	27	+93	+24	69	137	36	+116	+30	86	171	45
3-6	+47	-20	67	84	53	+70	-30	100	104	44	+93	-40	133	137	58	+116	-50	66	171	72
3-7	+47	-42	89	84	84	+70	-62	132	104	92	+93	-82	175	137	121	+116	-102	218	171	151
3-8	+47	-65	112	84	123	+70	-96	166	104	142	+93	-127	220	137	187	+116	-158	274	171	233
3-9	+47	-83	136	84	131	+70	-132	201	104	194	+93	-175	268	137	256	+116	-218	334	171	319
4-6	+20	-20	40	53	53	+30	-30	60	78	44	+40	-40	80	103	58	+50	-50	100	128	72
4-7	+20	-42	62	53	84	+30	-62	92	78	92	+40	-82	122	103	121	+50	-102	152	128	151
4-8	+20	-65	85	53	123	+30	-96	126	78	142	+40	-127	167	103	187	+50	-158	208	128	233
4-9	+20	-89	109	53	131	+30	-132	162	78	194	+40	-175	215	103	256	+50	-218	268	128	319
5-7	-12	-42	30	44	84	-18	-62	44	65	92	-24	-82	106	86	121	-30	-102	72	107	151
5-8	-12	-65	53	44	123	-18	-96	78	65	142	-24	-127	151	86	187	-30	-158	128	107	233
5-9	-12	-89	72	44	131	-18	-132	115	65	194	-24	-175	189	86	256	-30	-218	188	107	319
6-9	-20	-89	69	13	131	-30	-132	102	13	194	-40	-175	215	23	256	-50	-218	168	31	319

13.1 Accessories

Counter flange NGS-MFF_

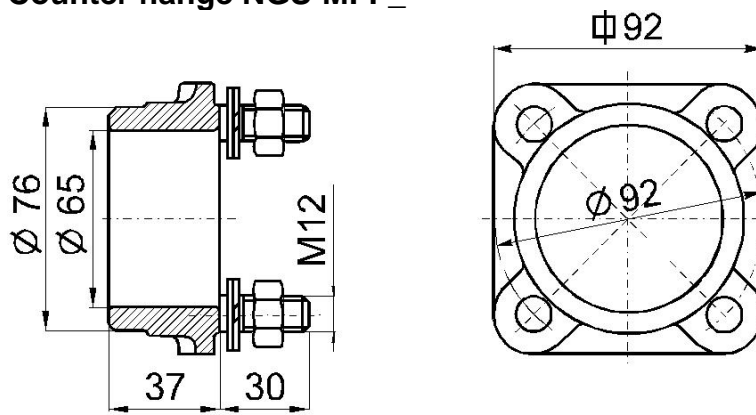

14. EU Declaration of Conformance

We, KOBOLD Messring GmbH, Hofheim-Ts, Germany, declare under our sole responsibility that the product:

Dual-Magnet Float Switches Model: NGS-... (without ATEX)

to which this declaration relates is in conformity with the standards noted below:

EN 61010-1:2011 Safety requirements for electrical equipment for measurement, control and laboratory use - Part 1: General requirements

EN 61326-1:2013 Electrical equipment for measurement, control and laboratory use - EMC requirements - Part 1: General requirements

EN 61326-2-3:2013 Electrical equipment for measurement, control and laboratory use - EMC requirements - Part 2-3: Particular requirements - Test configuration, operational conditions and performance criteria for transducers with integrated or remote signal conditioning

Also the following EU guidelines are fulfilled:

2014/30/EU EMC Directive

2011/65/EU RoHS

Furthermore for equipment with supply voltage <48 V:

2014/35/EU LVD

Hofheim, 02. Febr. 2017



H. Peters
General Manager



M. Wenzel
Proxy Holder

15. EU ATEX Declaration of Conformance

We, KOBOLD Messring GmbH, Hofheim-Ts, Germany, declare under our sole responsibility that the product:

Dual-Magnet Float Switches Model: NGS-... (with ATEX)

to which this declaration relates is in conformity with the standards noted below:

EN 61010-1:2011 Safety requirements for electrical equipment for measurement, control and laboratory use - Part 1: General requirements

EN 61326-1:2013 Electrical equipment for measurement, control and laboratory use - EMC requirements - Part 1: General requirements

EN 60079-0:2013
EN 60079-0:2013/A11:2014
Explosive atmospheres - Part 0: Equipment - General requirements

EN 60079-1:2015 Flameproof enclosures (Ex D)

EN 60079-7:2007 Increased safety (Ex e)

EN 60079-18:2015 Encapsulation (Ex m)

EN 60079-26:2015 Requirements for II 1 G

Also the following EU guidelines are fulfilled:

2014/30/EU EMC Directive

2011/65/EU RoHS

2014/34/EU ATEX

Quality Management Production

Certificate number: BVS 15 ATEX ZQS/E110

Notified body: DEKRA Exam GmbH



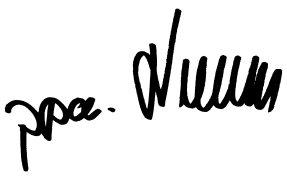

Identification number: 0158

Hofheim, 02. Febr. 2017

H. Peters
General Manager

M. Wenzel
Proxy Holder

16. ATEX Certificate

  Ex	
<p>(1) <i>EU-Típus Vizsgálati Tanúsítvány</i> <i>EU-Type Examination Certificate</i></p>	
<p>(2) A potenciálisan robbanásveszélyes környezetben történő alkalmazásra szánt berendezések, védelmi rendszerek 2014/34/EU Direktíva / Equipment or Protective Systems Intended for use in Potentially Explosive Atmospheres Directive 2014/34/EU</p>	
<p>(3) EU-Típus Vizsgálati Tanúsítvány száma / EU-Type Examination Certificate Number:</p>	<p>BKI16ATEX0034 X</p>
<p>(4) A gyártmány / Product: Mágneses billenőúszós szintkapcsoló család / Magnetic dumping float level switch family Típusa / Type: NGS-****Ex</p>	
<p>(5) Gyártó / Manufacturer: KOBOLD Messring GmbH</p>	
<p>(6) Cím / Address: Nordring 22-24, 65719, Hofheim am Taunus Germany</p>	
<p>(7) A gyártmány és annak változatai a jelen tanúsítvány vonatkozó pontjában vannak feltüntetve. / This product and any acceptable variation thereto is specified in the schedule to this certificate and the documents therein referred to.</p>	
<p>(8) A ExVÁ Robbanásbiztos Berendezések Vizsgáló Állomása Kft., 1418 sz. kijelölt testület, a 2014. február 26-i Európai Parlament és Tanács 2014/34/EU Direktívájának 17. cikkelye szerint tanúsítja, hogy a gyártmány megfelel az Alapvető Egészségügyi és Biztonsági Követelményeknek a Direktíva II. számú Mellékletében a potenciálisan robbanásveszélyes térben alkalmazásra szánt gyártmányok tervezése és gyártása szerint. / ExVÁ Testing Station for Explosion Proof Equipment Company Limited, notified body number 1418 in accordance with Article 17 of Directive 2014/34/EU of the European Parliament and of the Council, dated 26 February 2014, certifies that this product has been found to comply with the Essential Health and Safety Requirements relating to the design and construction of products intended for use in potentially explosive atmospheres given in Annex II to the Directive.</p>	
<p>A vizsgálat eredményeit az alábbi nyilvántartási számú bizalmas vizsgálati dokumentáció tartalmazza: / The examination and test results are recorded in confidential report No.:</p>	<p>R-060-16</p>
<p>Ez a tanúsítvány csak a maga egészében és változatlan formában használható fel, mellékleteivel együtt. / This certificate may only be reproduced in its entirety and without any changes, schedule included.</p>	<p>Lapszám / Page: 1/5</p>
	



BKI16ATEX0034 X
EU-Típus Vizsgálati Tanúsítvány/
EU-Type Examination Certificate

- (9) Az alapvető egészségügyi és biztonsági követelményeknek való megfelelést a következők biztosítják: /
Compliance with the Essential Health and Safety Requirements has been assured by compliance with:
- EN 60079-0:2012 (=MSZ EN 60079-0:2013)**
EN 60079-0:2012 / A11:2013 (=MSZ EN 60079-0:2013 / A11:2014)
EN 60079-1:2014 (=MSZ EN 60079-1:2015)
EN 60079-7:2007 (=MSZ EN 60079-7:2007)
EN 60079-18:2015 (=MSZ EN 60079-18:2015)
EN 60079-26:2015 (=MSZ EN 60079-26:2015)
- kivéve a 18. pontban felsorolt követelményekre vonatkozóan.
except in respect of those requirements listed at item 18 of the Schedule.
- (10) A tanúsítvány száma után álló „X” jel azt mutatja, hogy a gyártmány speciális feltételek megtartása mellett felel meg a jelen tanúsítvány vonatkozó pontjában feltüntetett biztonságos alkalmazás feltételeinek. /
If the sign „X” is placed after the certificate number, it indicates that the product is subject to Specific Conditions of Use specified in the schedule to this certificate.
- (11) Jelen EU-TÍPUS VIZSGÁLATI TANÚSÍTVÁNY csak a megjelölt gyártmány tervezésére és kivitelezésére vonatkozik. A jelen Direktíva további követelményei vonatkoznak a gyártmány gyártási folyamatára és szállítására. Ezek nem tartoznak e tanúsítvány alá /
This EU-TYPE EXAMINATION CERTIFICATE relates only to the design and construction of the specified product. Further requirements of this Directive apply to the manufacturing process and supply of this product. These are not covered by this certificate.
- (12) A gyártmány jele a következő /
The marking of the product shall include the following:



II 1/2 G Ex d e mb IIC T6...T2 Ga/Gb

(T_{körny} = táblázat szerint / T_{amb} = according to table)

ExVÁ Robbanásbiztos Berendezések
Vizsgáló Állomása Kft.
ExVÁ Testing Station for Explosion Proof
Equipment Ltd.
Hungary, 1037 Budapest, Mikoviny u. 2-4.
Tel.: 36 1 250 1720
E-mail: bkiex@bki.hu

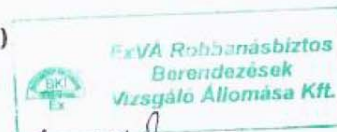

Müllner János

Müllner János

Ügyvezető igazgató / Managing director

Budapest, 2016. december / December 1.

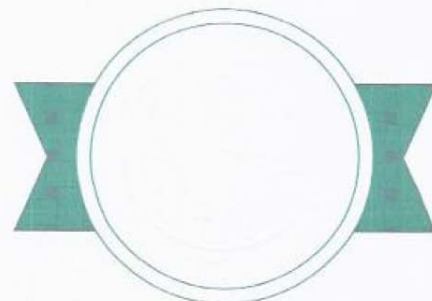

Ez a tanúsítvány csak a maga egészében és változatlan formában használható fel, melléketeivel együtt. /
This certificate may only be reproduced in its entirety and without any change, schedule included.

Lapszám / Page: 2/5





BKI16ATEX0034 X
EU-Típus Vizsgálati Tanúsítvány/
EU-Type Examination Certificate



(13) Melléklet / Schedule

(14) EU-TÍPUSVIZSGÁLATI TANÚSÍTVÁNY szám /
EU-TYPE EXAMINATION CERTIFICATE N^o
BKI16ATEX0034 X

(15) Gyártmány leírása / Description of Product

A NGS-****Ex típusú mágneses úszós szintkapcsoló kapcsolója nyomásálló tokozás „d” és légmentes lezárás kiöntéssel „mb” védelmi módú, a tokozása fokozott biztonság „e” védelmi móddal készített közvetlen kábelbevezetésű gyártmány.

A szintváltozás hatására elmozduló mágnes egy mikrokapcsolót működtet.

A csatlakozó kábel gumigyűrűvel tömített kábelbevezetőn lép be a fejrészben lévő csatlakozótérbe. A vezetékerek a mikrokapcsoló testébe ágyazott kapcsokra csavaros rögzítéssel csatlakoztathatók.

A fejrészt menetes illeszkedésű fedél zárja le. /

The switch of NGS-****Ex level switch type made covers products of the protection type flameproof enclosure „d”, and encapsulation „mb” – the enclosure has increased safety „e” with direct cable entry.

The magnet, moving off as the result of level change, operates a microswitch.

The connecting cable enters the connecting area in the head part through a cable entry sealed by means of a rubber ring. The wires can be connected onto the terminals of microswitch, embedded into the insulator body, by screwed fixing.

The head part is closed by a threaded cover.

15.1 Típusjel / Type mark

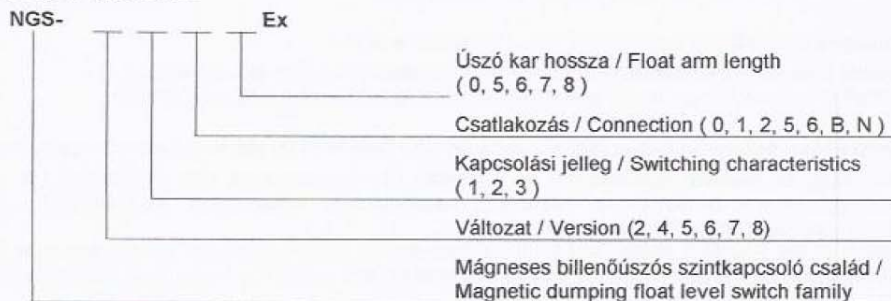

15.2 Műszaki adatok / Technical data

Villamos adatok / Electrical data

Beépített kapcsoló kapcsolási jellemzői: /
Parameters of built-in switch : 250 VAC / 2,5 A / AC12
220 VDC / 0,3 A / DC 13

Védettség / Ingress protection:

NGS-2*; NGS-51*; NGS-61* típusváltozatok esetén /
In case of types NGS-2*; NGS-51*; NGS-61*: IP 65

NGS-4*; NGS-7*; NGS-8* típusváltozatok esetén /
In case of types NGS-4*; NGS-7*; NGS-8*: IP 68

Érintésvédelem / Electric shock protection:

I. év. osztály MSZ 171/1-84 /
I. e.s. class according to MSZ 171/1-84

Ez a tanúsítvány csak a maga egészében és változatlan formában használható fel, mellékleteivel együtt. /
This certificate may only be reproduced in its entirety and without any change, schedule included.

Lapszám / Page: 3/5





BKI16ATEX0034 X
EU-Típus Vizsgálati Tanúsítvány/
EU-Type Examination Certificate



15.3 Hőmérsékleti határadatok / Data of temperature limit
Környezeti és közeghőmérséklet / Ambient and medium temperature

Hőmérsékleti osztály / Temperature class	Környezeti hőmérséklet tartomány / Ambient temperature range	Közeghőmérséklet tartomány / Medium temperature range
T6	-20°C...+60°C	-50°C...+80°C
T5	-20°C...+70°C	-50°C...+95°C
T4	-20°C...+80°C	-50°C...+130°C
T3	-20°C...+80°C	-50°C...+200°C
T2	-20°C...+80°C	-50°C...+250°C

kivéve / except:

NGS-51*

NGS-61*

T_{közeg/medium}: 0°C ... +100°C

T_{közeg/medium}: 0°C ... +200°C

Az alkalmazható közeghőmérséklet tartomány az alábbi ábra szerint korlátozódik /
The applicable medium temperature range limited by next diagram:

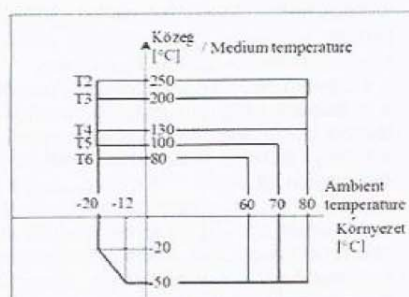

(16) Jegyzőkönyv / Report N°

R-060-16ATEX Értékelő Jelentés / ATEX Assessment Report

2016.12.01.

(17) Biztonságos üzemeltetés feltételei / Special conditions of Use

A kapcsoló áramkörét a kapcsolási paramétereknek megfelelő biztosítóval kell védeni. /
The circuit of the switch must be protected by fuse suitable for the switching parameters.

(18) Alapvető egészségügyi és biztonsági követelmények / Essential Health and Safety Requirements

Amellett, hogy az alapvető egészségügyi és biztonsági követelményeknek való megfelelést a 9. pontban felsorolt szabványok biztosítják, a következő megfontolások vonatkoznak a gyártmányra, melyek megfelelése jelezőkönyvben bizonyított:
In addition to the Essential Health and Safety Requirements (EHSRs) covered by the standards listed at item 9, the following are considered relevant to this product, and conformity is demonstrated in the report:

Záradék / Clause	Tárgy / Subject
N/A	N/A

Ez a tanúsítvány csak a maga egészében és változatlan formában használható fel, mellékleteivel együtt. /
This certificate may only be reproduced in its entirety and without any change, schedule included.

Lapszám / Page: 4/5





BK116ATEX0034 X
EU-Típus Vizsgálati Tanúsítvány/
EU-Type Examination Certificate



(19) Rajzok és dokumentációk / Drawings and Documents

Szám / Number	Lap / Sheet	Kiadás / Issue	Dátum / Date	Leírás / Description
NGS K04/1116 (sheet 16)	1	-	2016.11.23.	EU-Megfelelőségi Nyilatkozat / EU-Declaration of Conformity
NGS-2100 Ex.	1	0	2016.11.03.	Adattábla / Ex data plate
NGS K04/1116	16	1	2016 November	Használati utasítás / Operating instructions
303.004	1	2	2016.11.30	rendelési jelölés / cross reference codes
-	1	-	2016.07.13	Jóváhagyó levél / Letter of Consent

Müllner János
Ügyvezető igazgató /
Managing director



Molnár Edit
Tanúsító Szervezet Vezető /
Head of Certification Body

Ez a tanúsítvány csak a maga egészében és változatlan formában használható fel, mellékleteivel együtt. /
This certificate may only be reproduced in its entirety and without any change, schedule included.

Lapszám / Page: 5/5

