

Operating Instructions for Bypass Level Indicator

Model: NBK

Order from: **C A Briggs Company**
622 Mary Street; Suite 101; Warminster, PA 18974
Phone: 267-673-8117 - Fax: 267-673-8118
Sales@cabriggs.com - www.cabriggs.com

1. Contents

1. Contents.....	2
2. Note	3
3. Instrument Inspection.....	4
4. Regulation Use.....	4
4.1. Bypass Measuring Tube System	4
4.2. Electrical Limit Switches (option)	5
4.3. Remote Sensor with Reed Contact Chain of Resistors (option ..M.. / option ..W..)	5
4.4. Remote Sensor with Magnetostrictive Pick-Up (option ..T..).....	5
5. Operating Principle.....	5
6. Mechanical Connection.....	7
7. Electrical Connection	9
7.1. Limit contacts NBK-R, NBK-RT	9
7.2. Remote Sensor: Reed Contact Chain of Resistors (option ..W..)	10
7.3. Remote Sensor: Chain of Resistors with 2-wire Transmitter (option ..M..).....	11
7.4. Remote Sensor: Magnetostrictive Sensor with 4-wire Transmitter (option ..T..)	12
8. Commissioning.....	13
9. Trouble Shooting.....	14
10. Maintenance	14
11. Technical Information.....	15
12. Options.....	17
13. Order Codes	18
14. Dimensions	19
15. Declaration of Conformance	20

Manufactured and sold by:

Kobold Messring GmbH
Nordring 22-24
D-65719 Hofheim
Tel.: +49(0)6192-2990
Fax: +49(0)6192-23398
E-Mail: info.de@kobold.com
Internet: www.kobold.com

2. Note

Please read these operating instructions before unpacking and setting the unit into operation. Follow the instructions precisely as described herein.

The devices are only to be used, maintained and serviced by persons familiar with these operating instructions and in accordance with local regulations applying to Health & Safety and prevention of accidents.

When used in machines, the measuring unit should be used only when the machines fulfil the EWG-guidelines.

as per PED 97/23/EG

Model	Total by-pass-length	p max [bar]	Medium dangerous (Diagr. 2)	non dangerous	Medium dangerous (Diagr. 1)
NBK-01	<= 645	16	Art.3, Para.3		Art.3, Para.3
NBK-01	<= 1270	16	Art.3, Para.3		I
NBK-01	<= 5040	16	I		II
NBK-01	>= 6420	16	II		III
NBK-03	<= 645	16	Art.3, Para.3		Art.3, Para.3
NBK-03	<= 1270	16	Art.3, Para.3		I
NBK-03	<= 5040	16	I		II
NBK-03	>= 6420	16	II		III
NBK-04	<= 645	16	Art.3, Para.3		Art.3, Para.3
NBK-04	<= 1270	16	Art.3, Para.3		I
NBK-04	<= 5040	16	I		II
NBK-06	<= 250	40	Art.3, Para.3		Art.3, Para.3
NBK-06	<= 500	40	Art.3, Para.3		I
NBK-06	<= 2000	40	I		II
NBK-06	<= 6500	40	II		III
NBK-07	<= 167	64	Art.3, Para.3		Art.3, Para.3
NBK-07	<= 335	64	Art.3, Para.3		I
NBK-07	<= 1341	64	I		II
NBK-07	<= 6500	64	II		III
NBK-10	<= 107	100	Art.3, Para.3		Art.3, Para.3
NBK-10	<= 215	100	Art.3, Para.3		I
NBK-10	<= 858	100	I		II
NBK-10	<=4292	100	II		III
NBK-10	<= 6500	100	III		IV
NBK-12; 13; 14	<= 1470	6	Art.3, Para.3		Art.3, Para.3
NBK-12; 13; 14	<= 2974	6	Art.3, Para.3		I

3. Instrument Inspection

Instruments are inspected before shipping and sent out in perfect condition. Should damage to a device be visible, we recommend a thorough inspection of the delivery packaging. In case of damage, please inform your parcel service / forwarding agent immediately, since they are responsible for damages during transit.

Scope of delivery:

The standard delivery includes:

- Bypass Level Indicator model: NBK
- Operating Instruction

4. Regulation Use

Any use of the Bypass level Indicator, model: NBK, which exceeds the manufacturer's specification may invalidate its warranty. Therefore, any resulting damage is not the responsibility of the manufacturer. The user assumes all risk for such usage.

The NBK Bypass Level Indicator is used for continuous measurement, indication, and monitoring of liquids in tanks, vessels, reservoirs, basins etc. The indication occurs via a magnetically coupled roller indicator.

4.1. Bypass Measuring Tube System

The bypass tube is attached at the side of the vessel with a connecting flange or a threaded pipe. The installation position is always vertical. The NBK should only be used for liquids with the medium density specified on the nameplate. Otherwise the indication will deviate (float too high or submerged).

Vessel inner pressure and medium temperature should not exceed the specified maximum values, as this can lead to the destruction and malfunction of the bypass system. It is imperative that the materials used are compatible with the liquid being measured.

Proper operation is also impaired by:

- High degree of soiling
- Suspended solids
- Crystallisation
- Ferrite particles

4.2. Electrical Limit Switches (option)

The optional electrical limit switches serve to signal a preset level.

NBK-R: Bistable changeover contact fitted in a polycarbonate housing with 3m connection cable

NBK-RT200/-RT400: Bistable changeover contact fitted in an aluminium die cast housing with terminal connectors

4.3. Remote Sensor with Reed Contact Chain of Resistors (option ..M.. / option ..W..)

The optional remote electrical sensor converts the liquid level to a resistance value, which serves to transmit the level as a varying electrical signal. Down-stream control electronics transform the signal to a standard analogue value (e.g., 4–20 mA), or control the level.

4.4. Remote Sensor with Magnetostrictive Pick-Up (option ..T..)

Remote level transmission can be achieved by mounting a magnetostrictive sensor outside the bypass tube. A continuous standard 4 to 20 mA signal is obtained with a built-in transmitter. This signal can then be displayed on analogue or digital indicators.

Please pay attention to the maximum medium and ambient temperatures.

5. Operating Principle

Kobold Bypass Level Indicators are used for continuous measurement, display and monitoring of liquid levels. The bypass tube is attached onto the side wall of the vessel. According to the law of communicating tubes the level in the bypass tube equals the level in the vessel. A float with embedded circular magnets in the bypass tube follows the liquid level and transfers it in a non-contacting manner to a display fitted outside the tube or to a monitoring device. The following indication and monitoring devices are available:

Magnetic roller indicator

As the float passes by, the red/white rollers are rotated in succession by 180° around their own axes. The rollers change from white to red as the level rises and from red to white as the level falls. The level in a tank or a mixer is continuously displayed as a red column, even when the power fails.

Transmitter

To remotely transmit the level a transmitter with a chain of resistors or a magnetostrictive transducer can be mounted outside the bypass tube.

The contacts of a reed contact chain are connected or disconnected via the float movement in a non-contacting manner. Depending on the level, the number of connected resistors changes and as a consequence the output of the total resistor value.

A continuous standard signal of 4 to 20 mA is generated by means of a fitted transmitter. This standard signal can then be displayed on analogue or digital indicating devices.

Universal indicating unit

A universal indicating unit of type series ADI can be mounted on the bypass to display and evaluate the standard signal (4–20 mA) generated by the transmitter.

Limit contacts

One or more reed contacts for limit-value acquisition or also for level control can be attached to the bypass tube.

ATEX version

The bypass level indicators can be supplied with ATEX approval. As an option limit contacts and a reed contact chain with ATEX approval are available for level measurement and monitoring.

ATEX approval:

Bypass-level indicator: Ex II 1G /2GD (mechanical)

Limit contact NBK-RA: Ex II 2G EEx m II T6 / T5

Immersible magnetic probe

(Reed contact chain): Ex II 1G EEx ia IIC T6

Transmitter for Reed chain: Ex II (1) G [EEx ia] IIC

GL version

In the pressure stages PN 16 (NBK-03) and PN 40 (NBK- 06) the bypass level indicators are available with GL approval (Germanischer Lloyd). The magnetic roller indication as well as limit contacts and a reed contact chain can be delivered for level indication and evaluation .

Certificate-No. GL: 79 786-95 HH

6. Mechanical Connection

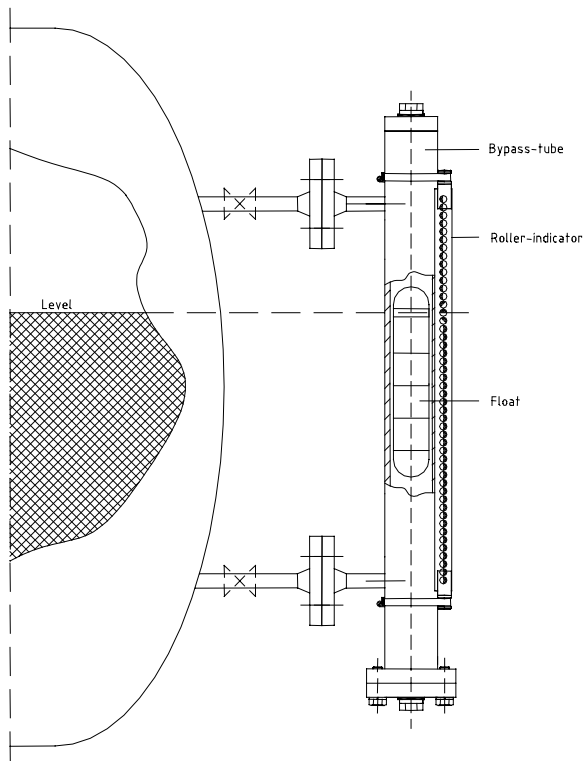

Remove bottom flange from bypass tube, and insert the cylindrical float in the NBK bypass tube with the designation "TOP" at the top. Re-position the gasket and close the bottom flange again; firmly tighten with screws.

Mount the bypass tube to the vessel to be monitored via the process connection and seal with an appropriate device. Normally it is sufficient to fix the complete NBK with both process connections. However should the NBK be subjected to constant shock or strong vibrations it is recommended that the instrument is secured with rubber-damped tube clips. No welding is allowed on the bypass tube.

Mount and tighten the **magnetic roller indicator** - if not already mounted - on the bypass tube with the two provided ribbon clamps.

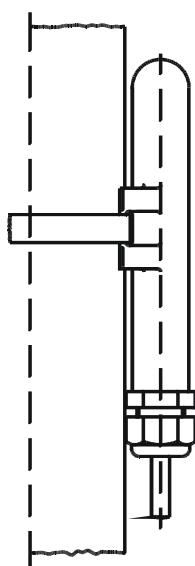

Mount and tighten the **reed switch** - if available.- on the bypass tube at the opposite side of the roller indicator with the provided ribbon clamps (ex contact: two ribbon clamps). The height of the switch contacts may be selected at will. The cable connection must point downwards. The switch must be attached close to the bypass tube. The switching function of the switch is impaired by an enlarged air gap.

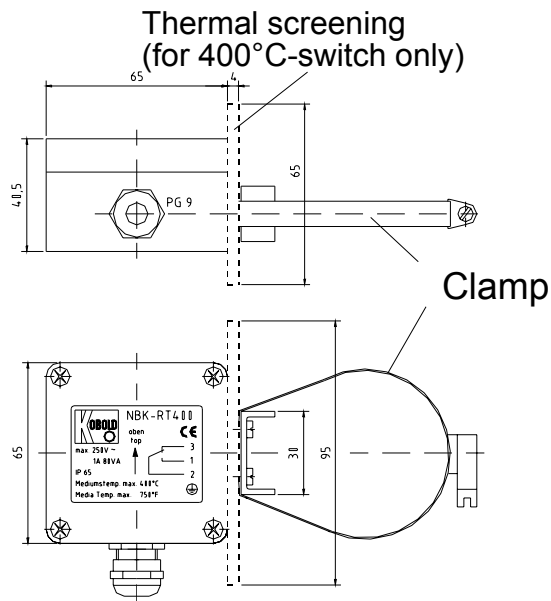

The **high temperature switch** will be mounted to the bypass tube with the tube clip fixed at the contact housing.

Mount and tighten the **remote sensor** - if available and not already mounted - on the bypass tube with the ribbon clamps. The remote sensor must fully cover both process connections. The cable terminal box is situated at the top.

7. Electrical Connection

7.1. Limit contacts NBK-R, NBK-RT



Attention!

Observe the allowed electrical ratings for the limit switch.

Maximum values	NBK-R Standard contact	NBK-RT High temperature contact
Switching capacity:	60 W/VA	80 VA
Switching current:	1 A	1 A
Switching voltage:	230 V _{AC/DC}	250 V _{AC/DC}

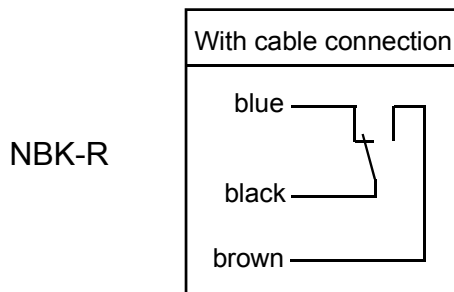

Install the switch (if available) according to the diagram and connect it to the electrical controller.

When switching inductive loads, such as contactors, relays, etc, electrical limit values should not be exceeded by e.g. voltage peaks. The use of a contact protection relay is recommended to avoid overloading the reed contacts.

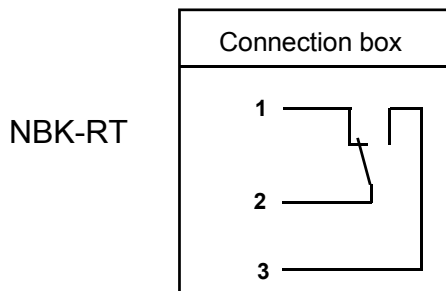

Valid regulations for hazardous areas, and regulations for installation (DIN/VDE 0165), should be observed when installing the NBK level indicator in zone 1 or 2 hazardous areas (no combustible liquids).

7.2. Remote Sensor: Reed Contact Chain of Resistors (option ..W..)

- Ensure that the electrical supply lines are powerless.
- To avoid faults caused by electrical fields from other circuits, the cables should not be installed adjacent to other high voltage power lines.
- Unscrew cover and run supply lines through cable gland.
- Connect the remote sensor to the electronics according to the following table.

	Transmitter "top"	Transmitter "bottom"	Pick-off	
Silicon cable	White	brown	green	
PVC cable	White	brown	green	
FEP cable	brown	blue	black	
Adapter box	terminal 1	terminal 2	terminal 3	
Internal*	yellow	red	black	



***Please note: The colours of internal cables are for internal connections only and therefore are only visible in transmitters with terminal connection box.**

When connecting remote sensors to a Kobold transmitter, for example models DFA, DST or DFM, please read the relevant operating instructions.

7.3. Remote Sensor: Chain of Resistors with 2-wire Transmitter (option ..M..)

- Ensure that the electrical supply lines are powerless.
- To avoid faults caused by electrical fields from other circuits, the cables should not be installed adjacent to other high voltage power lines.
- Unscrew cover and run supply lines through cable gland.
- Connect the remote sensor to the electronics according to the wiring diagram below.

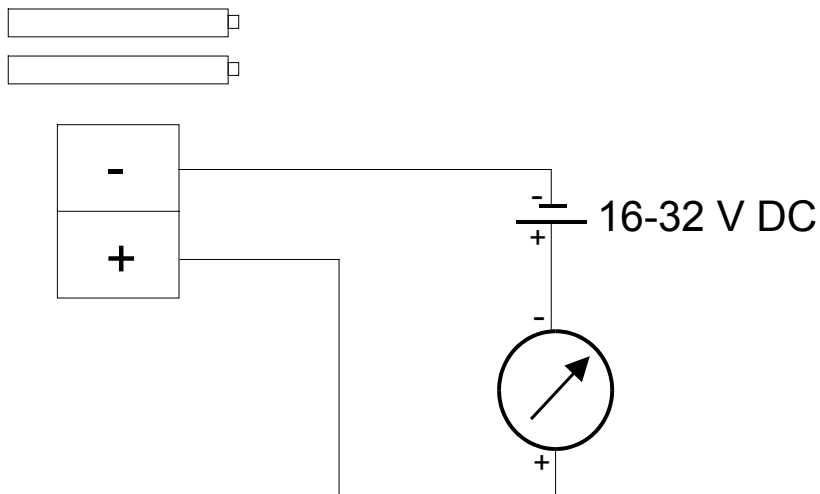

7.4. Remote Sensor: Magnetostrictive Sensor with 4-wire Transmitter (option ..T..)

- Ensure that the electrical supply lines are powerless.
- To avoid faults caused by electrical fields from other circuits, the cables should not be installed adjacent to other high voltage power lines.
- Unscrew cover and run supply lines through cable gland.
- Connect the remote sensor to the electronics according to the terminal connection diagram below.

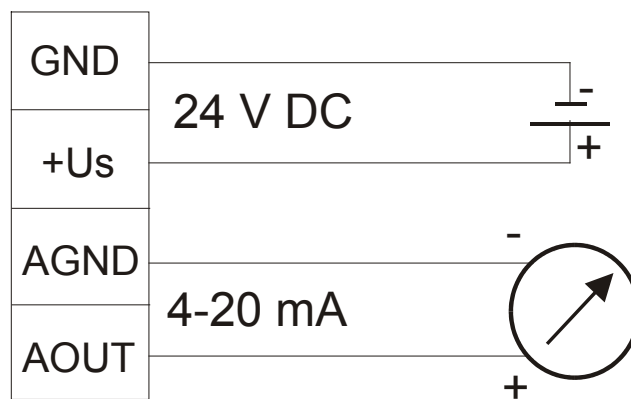
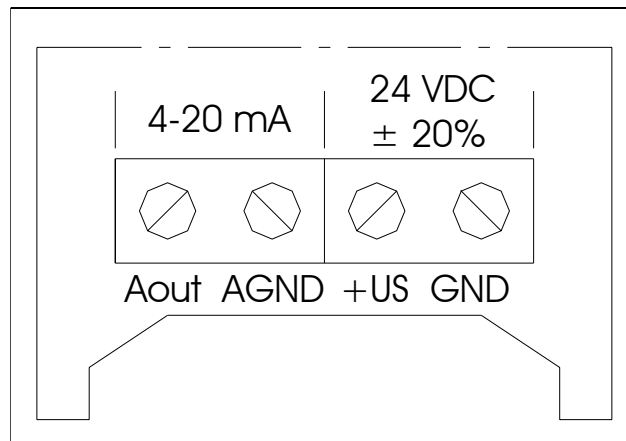

8. Commissioning

Because of the setting behaviour of seals, all screw connections must be retightened.

Fill vessel and switch on electrical controller, if available. If there are gate valves between bypass process connection and tank, first slowly open the upper valve (pressure relief) and then the lower valve (liquid side). If vent and drain valves have been installed, close them before filling.

The liquid that now enters the bypass tube raises the float until the level between tank and bypass tube is balanced. The roller indicator indicates the liquid level.

Commissioning electrical reed switches

Function of switches

All switches have three connection poles (black (2), blue (1) and brown (3)).

The black wire (2) is the common pole for both switching functions (N/C and N/O contact).

The float must pass the switch once in both directions so that the switching function is in line with the terminal connection diagram and table below.

These instructions are often ignored when an alarm lamp is connected directly with the result that the alarm lamp incorrectly indicates a fault.

When the switch has been passed, it is ready for operation and requires no maintenance.

	black (2) / blue (1)	black (2) / brown (3)
float above	open	closed
float below	closed	open

Hysteresis

Hysteresis is the difference between contact closing and opening points. A hysteresis of approximately 15 mm float travel is achieved by factory tuning of the float magnet and contact strength.

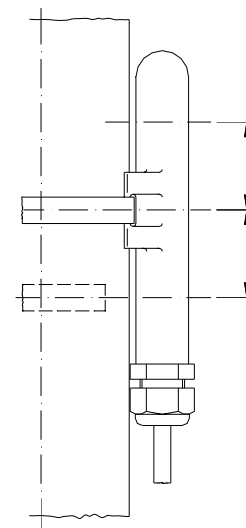

9. Trouble Shooting

Error: The tank is full but there is no indication

- Check that both flanges (process connection), top and bottom, are open to the vessel, and that the bypass tube fills with liquid.
- Check that there is a float in the system.
- When the float is installed, check whether it is being blocked by foreign objects or dirt deposits.

Error: The tank is full but the indication is too low.

- Check that the density of the liquid is the same as the density given on the nameplate.
- Check that the float has been correctly installed with the marking "TOP" at the top.
- Check if dirt deposits in the bypass tube are blocking the float.

10. Maintenance

The drain plug should be opened occasionally, to wash out any deposits in case the liquid to be measured contains dirt particles, which could settle in the bypass tube.

If crust formation or crystallisation has taken place, the tank must be emptied or shut off; the lower cover flange must then be removed. The float should then be removed carefully out of the bypass. The bypass tube can now be mechanically cleaned.

The inspection window for the roller indication is made of high-quality plexiglass (glass for high-temperature display). It should be cleaned with a suitable cleaning agent.

The indicator requires no further maintenance.

11. Technical Information

Process Connection:	Flange DIN EN 1092-1, type 11, form B, ANSI flange R-thread DIN EN 10266-1 NPT thread DN 15, DN 20, DN 25, DN 32
Bypass tube:	Ø 60.3 mm, 1.4571
Flat gasket	
NBK-03,-06,-07:	<200 °C: PTFE; ≥200 °C: Klinger SIL
NBK-10:	graphite with insert
Operating pressure:	PN 16/40/64/100
Service temperature:	up to 120 °C: PP rollers, up to 400 °C: ceramic rollers
Viscosity:	max. 200 mm ² /s
Max. measuring length:	up to 6000 mm: single-part, >6000 mm: two-part or multipart
Overall length:	see dimension drawing

Technical Information for additional components

Limit contacts model NBK-R

Contact operation:	bistable changeover contact
Switching hysteresis:	approximately 15 mm
Max. switching capacity:	60 W/VA; 230 V _{AC/DC} ; 1 A
Resistance:	100 mΩ
Medium temperature:	max. 100 °C
Ambient temperature:	max. 75 °C
Connection:	3 m PVC cable
Housing:	polycarbonate
Protection:	IP 67

Limit contacts high temperature model NBK-RT200, NBK-RT400

Contact operation:	bistable changeover contact
Switching hysteresis:	approximately 15 mm
Max. switching capacity:	80 VA; 250 V _{AC/DC} ; 1 A
Resistance:	< 20 mΩ
Medium temperature:	max. 200 °C / 400 °C
Ambient temperature:	max. 145 °C / 350 °C
Housing:	aluminium pressure-cast housing, terminal connectors
Protection:	IP 65

Reed contact resistor chain model: ...W...

Total resistance:	approx. 5 k Ω
Measuring-circuit voltage:	max. 24 V _{DC}
Measuring current:	max. 0.1 A
Medium temperature:	max. 200 °C 400 °C with thermal screening (option N)
Ambient temperature:	max. 130 °C
Resolution:	10 mm (ML < 2000 mm) 20 mm (ML \geq 2000 mm)
Housing:	Aluminium pressure-cast
Protection:	IP 65

**Reed contact resistor chain
with 2-wire transmitter model: ...M...**

Output:	4-20 mA
Power supply:	16-32 V _{DC}
Load:	(U _B -9V)/0.02A [Ω]
Medium temperature:	max. 120 °C
Ambient temperature:	max. 80 °C
Resolution:	10 mm (ML < 2000 mm) 20 mm (ML \geq 2000 mm)
Protection:	IP 65

**Magnetostrictive sensor
with 4-wire transmitter model: ...T...**

Output:	4-20 mA
Power supply:	24 V _{DC} , max. 150 mA
Load:	max. 500 Ω
Max. length:	4000 mm
Medium temperature:	max. 120 °C
Ambient temperature:	max. 80 °C
Accuracy:	\pm 1mm
Housing:	Aluminium pressure-cast
Protection:	IP 65

12. Options

Options NBK-03...

- B*- indicating unit type ADI-B with bargraph, rugged aluminium casing mounted on bypass tube, for description see brochure Z2
- C*- indicating unit type ADI-K with bargraph and digital display, rugged aluminium casing, mounted on bypass tube, for description see brochure Z2
- D*- indicating unit type ADI-D with digital display, rugged aluminium casing, mounted on bypass tube, for description see brochure Z2
- A- connecting flange for two-part design
- E5- drain flange DN 20 stainless steel 1.4571
- E6- drain flange DN 25 stainless steel 1.4571
- F1- drain valve NAD-MZ 15 G1/2, stainless steel 1.4571
- F2- drain valve NAD-MZ15 1/2 NPT, stainless steel 1.4571
- H3- rinsing connection DN15, PN16, top and bottom for NBK-03
- H4- rinsing connection 1/2" ANSI, 150 lbs, top and bottom for NBK-03
- K- Armaflex insulation (thermal conductance 0.025 kcal/m °C, up to 105 °C)
- M1- Measuring scale up to 400°C, aluminium backing, engraved scale
- M2- Measuring scale up to 120°C, aluminium backing with polyester foil scale
- N- thermal screening for transmitter type ...W...: 200-400 °C
- P- radiographic examination DIN 54 111 T1
- Q- dye penetration test DIN EN 571-1
- X- pressure test with water 1.5 x PN
- Z- 3.1 certificate according to EN 10204

*Use only with option T (magnetostrictive measuring sensor)
or option M (resistor chain with measuring transducer)

13. Order Codes

Order Details (Example: NBK-03 F15 00 0 A)

Model	Nominal pressure	Connection	Nominal size	Roller indication	Transmitter	Medium density Float
NBK-03...	PN 16/150 lbs	F =DIN flange	15 =DN 15, 1/2"	00 = without	0 = without transmitter	A =1.0 kg/dm ³ , titanium
NBK-06...	PN 40/300 lbs	A =ANSI flange	20 =DN 20, 3/4"	RP = PP rollers	T = magnetostrictive	B =0.90 kg/dm ³ , titanium
NBK-07...	PN 63/600 lbs	R =R thread	25 =DN 25, 1"	RK = ceramic	W = chain of resistors	C =0.80 kg/dm ³ , titanium
NBK-10...	PN 100/1500 lbs	N =NPT thread	32 =DN 32, 1 1/4"	rollers	M = chain of resistors and transmitter	D =0.70 kg/dm ³ , titanium
NBK-R	Standard limit contact (bistable changeover contact)					
NBK-RT200	High-temperature limit contact max. 200°C					
NBK-RT400	High-temperature limit contact max. 400°C					

*not possible with NBK-10

Please specify measuring length L, density, pressure and temperature in writing !

14. Dimensions

**NBK-...
with roller indication**

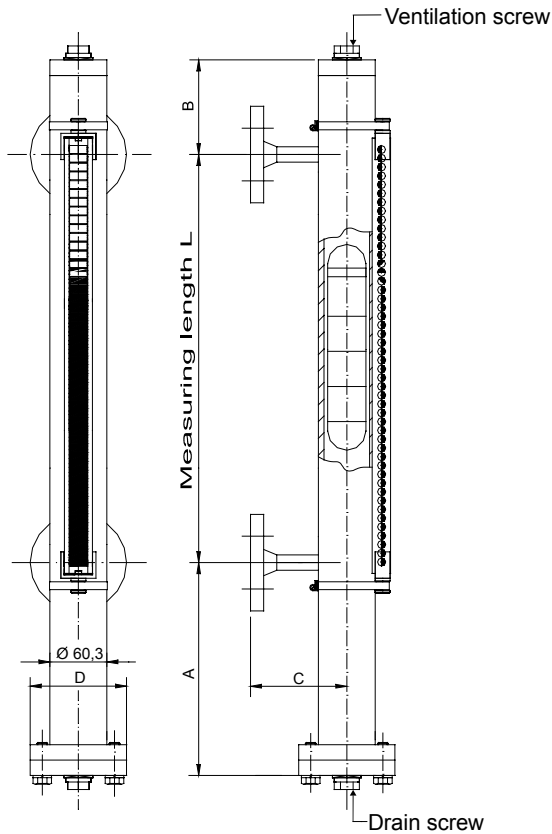

**NBK-...
with magnetostrictive transmitter**

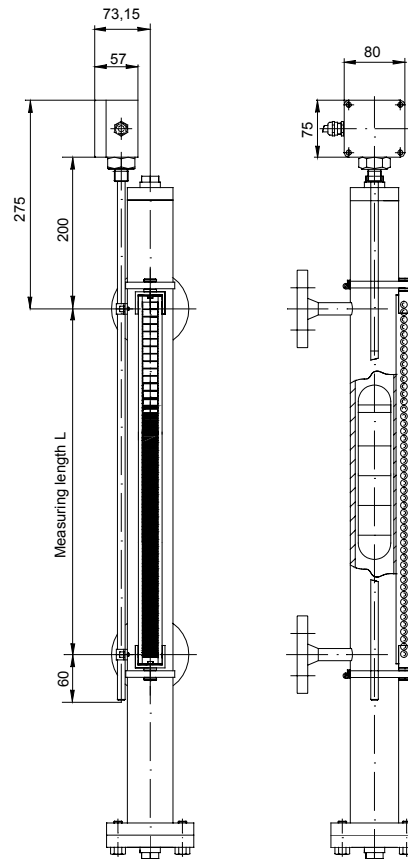

Dimensions NBK

Model	Nominal pressure	Dimensions [mm]		
		B	C	D
NBK-03...	PN 16 / 150 lbs	130	110	115
NBK-06...	PN 40 / 300 lbs	130	110	115
NBK-07...	PN 63 / 600 lbs	130	130	180
NBK-10...	PN 100 / 1500 lbs	130	130	195

NBK 10 always without ventilation screw and drain screw.

Clearance dimension A [mm]

Model	Nominal pressure	Medium density					
		0,54 [kg/dm ³]	0,6 [kg/dm ³]	0,7 [kg/dm ³]	0,8 [kg/dm ³]	0,9 [kg/dm ³]	1 [kg/dm ³]
NBK-03...	PN 16 / 150 lbs	320	320	320	320	320	210
NBK-06...	PN 40 / 300 lbs	410	410	320	320	320	210
NBK-07...	PN 63 / 600 lbs	410	410	320	320	320	210
NBK-10...	PN 100 / 1500 lbs	-	700*	410**	320	320	210

*800 at instruments with thermal screening; **450 at instruments with thermal screening

15. Declaration of Conformance

We, KOBOLD Messring GmbH, Hofheim-Ts, Germany, declare that the limit contacts for bypass level indicator fulfil the following standards:

Model	Pressure stage	Category as per PED	EC type examination test
NBK-01	PN 16	III	43 629-02 HH
NBK-03	PN 16	III	43 629-02 HH
NBK-06	PN 40	III	43 630-02 HH
NBK-07	PN 63	III	43 626-02 HH
NBK-10	PN 100	IV	43 627-02 HH

The limit contact for bypass level indicators **NBK-R**, **NBK-RT** are in conformity with the standards noted below:

DIN EN 61010-1 1994-03

Safety requirements for electrical measuring, control and laboratory instruments

EN 60529, DIN VDE 0470-1 1992-11

Protection type through case (IP code)

The bypass level indicator with remote sensor

model NBK-...M...

model NBK-...T...

model NBK-...W...

to which this declaration relates is in conformity with the standards noted below:

EN 61326: 1997 +A1: 1998 +A2:2001

Electrical equipment for measurement, control and laboratory use

- Noise immunity: according EN 61326/A1 Amendment B table B.1
Criteria: according table 2, continuous not monitored operation

- Generic emission standard: according EN 61326/A1
Limit values: according table 4, equipment of class B

EN 60529, DIN VDE 0470-1 1992-11

Protection type through case (IP code)

Also the following EWG guidelines are fulfilled:

73/23 EWG
89/336/EWG
97/23/EG

Low voltage guideline
Electromagnetic compatibility
PED

Category III (IV), Table 1, pipe, Group 1 dangerous fluids
Module B+D, mark CE0098
Notified body: Germanischer Lloyd Germany

Hofheim, 04. June 2004



H. Peters
General Manager



M. Wenzel
Proxy Holder