

Operating Instruction
for
Mini Bypass Level
Indicator

Model: NBK-M

Order from: **C A Briggs Company**
622 Mary Street; Suite 101; Warminster, PA 18974
Phone: 267-673-8117 - Fax: 267-673-8118
Sales@cabriggs.com - www.cabriggs.com

1. Contents

1. Contents.....	2
2. Note	3
3. Instrument Inspection.....	3
4. Regulation Use	4
4.1. Bypass measuring tube system	4
4.2. Electrical limit switches (option).....	4
4.3. Remote Sensor Reed Contact Chain of Resistors (option ..M.. / option ..W..).....	5
4.4. Remote sensor magnetostrictive sensor (option ..T..)	5
5. Operating Principles.....	5
6. Mechanical Connection.....	6
7. Electrical Connection	7
7.1. Switch (option).....	7
7.2. Remote Sensor Reed Contact Chain of Resistors (option ..W..).....	7
7.3. Remote Sensor Chain of Resistors with 2-wire Transmitter (option ..M)	8
7.4. Remote Sensor: Magnetostrictive Sensor with 4-wire Transmitter (option ..T..)	8
8. Commissioning.....	9
9. Trouble Shooting.....	11
10. Maintenance	11
11. Technical Information.....	12
12. Order Codes	13
13. Dimensions	14
14. Options.....	16
15. EU Declaration of Conformance	17

Manufactured and sold by:

KOBOLD Instruments Inc.
1801 Parkway View Drive
Pittsburgh PA 15205-1422
Tel.: 412-788-2830
Fax: 412-788-4980
E-Mail: info@koboldusa.com
Internet: www.koboldusa.com

2. Note

Please read these operating instructions before unpacking and putting the unit into operation. Follow the instructions precisely as described herein.

The devices are only to be used, maintained and serviced by persons familiar with these operating instructions and in accordance with local regulations applying to Health & Safety and prevention of accidents.

When used in machines, the measuring unit should be used only when the machines fulfil the EWG-guidelines.

Classification per PED 2014/68/EU

In acc. with Article 4, Paragraph 3, "Sound Engineering Practice", of the PED 2014/68/EU no CE mark.

Diagram 1, Pipe, Group 1 dangerous fluids

Diagram 2, Pipe, Group 2 no dangerous fluids

3. Instrument Inspection

Instruments are inspected before shipping and sent out in perfect condition.

Should damage to a device be visible, we recommend a thorough inspection of the delivery packaging. In case of damage, please inform your parcel service / forwarding agent immediately, since they are responsible for damages during transit.

Scope of delivery:

The standard delivery includes:

- Mini Bypass Level Indicator model: NBK-M
- Operating Instructions

4. Regulation Use

Any use of the Mini-Bypass Level Indicator, model: NBK-M, which exceeds the manufacturer's specifications, may invalidate its warranty. Therefore, any resulting damage is not the responsibility of the manufacturer. The user assumes all risk for such usage.

The NBK-M Mini Bypass Level Indicator is used for continuous measurement, indication, and monitoring of liquids in tanks, vessels, reservoirs, basins etc. Information is displayed on a magnetically coupled roller indicator.

4.1. Bypass measuring tube system

The bypass tube is attached at the side of the vessel with a connecting flange or threaded pipe. The installation position is always vertical. The NBK should only be used for liquids with the medium density specified on the nameplate. Otherwise the indication will deviate and the float may sink or float too high. Vessel inner pressure and medium temperature should not exceed the specified maximum values, as this can lead to the destruction and/or malfunction of the bypass system. It is imperative that the materials used are compatible with to the liquid being measured.

Proper operation is also impaired by:

- High degree of soiling
- Large suspended particles
- Crystallisation
- Ferrite particles

4.2. Electrical limit switches (option)

The optional electrical limit value controllers serve to signal a preset level.
Important!



Attention!

Observe the approved electrical ratings for the limit value controller.

Maximum values	Standard contact	High temperature contact
Breaking capacity:	60 VA	80 VA
Switching current:	0.8 A	1 A
Switching voltage:	230 V	230 V

4.3. Remote Sensor Reed Contact Chain of Resistors (option ..M.. / option ..W..)

The optional remote electrical sensor converts the liquid level to a resistance value, which serves to transmit the level as an electrical signal. Downstream control electronics transform the signal to a standard signal (e.g. 4–20 mA), or control the level.

Please note max. medium and ambient temperatures.

4.4. Remote sensor magnetostrictive sensor (option ..T..)

Remote level transmission can be achieved by mounting a magnetostrictive sensor outside the bypass tube. A continuous standard 4 to 20 mA signal is obtained with a built-in transmitter. This signal can then be displayed on analogue or digital indicators.

Please pay attention to the maximum medium- and the ambient temperatures!

5. Operating Principles

The NBK-M works according to the principle of communicating tubes with a float, that is, the level in the bypass tube corresponds to the level in the vessel. A float with encased ring magnet in the bypass tube follows the liquid level, and transfers it, in a non-contacting manner, to a roller indicator that is externally attached. As the float passes by, the red/white rollers rotate through 180° about their own axis. Red indicates the actual level, whereas white means no level.

Contact devices and / or remote sensors can also be fitted. The arrangement is not important as the annular magnetic field acts in all directions.

6. Mechanical Connection

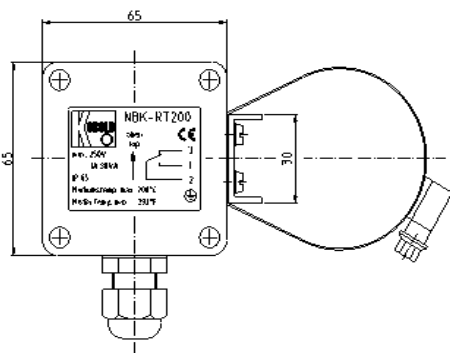
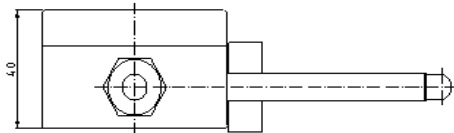
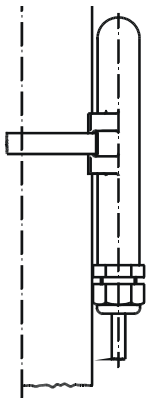
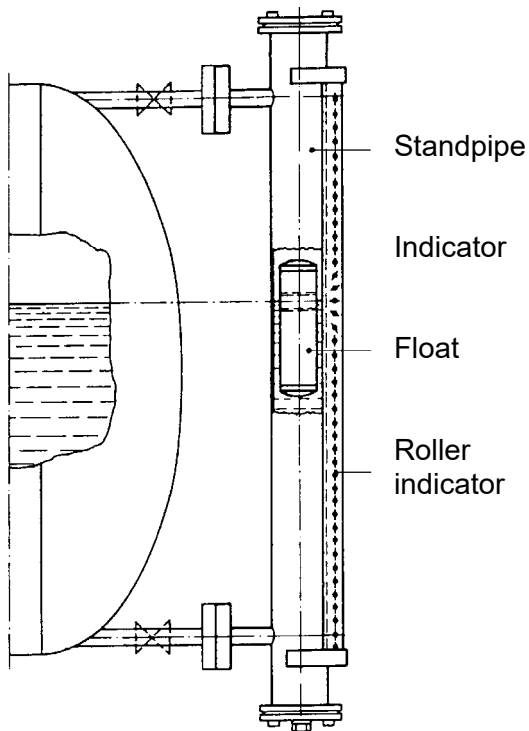

Remove bottom flange from bypass tube, and insert the cylindrical float in the NBK bypass tube with the designation "TOP" at the top. Re-position the gasket and close the bottom flange again; firmly tighten with screws. Mount and tighten the bypass tube to the vessel to be monitored with process connection and seal.

Normally it is sufficient to fix the complete NBK with both process connections. However, should the NBK be subjected to constant shock or strong vibrations it is recommended that the instrument is secured with rubber-damped tube clips.

The bypass tube should never be welded.

Mount and tighten the **magnetic roller indicator** - if not already mounted - on the bypass tube with the two accompanying ribbon clamps.

Mount and tighten the **reed switch** - if available and not already mounted - on the bypass tube at the opposite side of the roller indicator with the accompanying ribbon clamp (ex contact: 2 ribbon clamps).

The height of the switch contacts may be selected at will. The cable connection must point downwards. Tighten the tube clips until the gap cannot be closed any further. The switch must be snug against the stand tube. The switching function of the switch is impaired by an enlarged air gap.

Mount and tighten **remote sensor** - if available and not already mounted - on the bypass tube with the ribbon clamp.

The remote sensor must cover both process connections fully. The cable terminal box is situated at the top.

7. Electrical Connection

7.1. Switch (option)

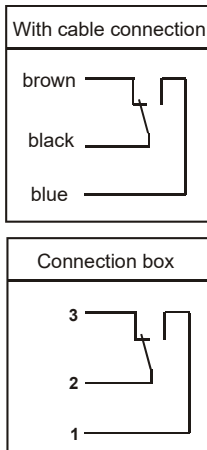

Connect switch (if available) according to the diagram, and connect to the electrical controller.

When switching inductive loads, such as, contactors, relays, etc, electrical limit values should not be exceeded by surges or spikes, for instance. The use of a contact protection relay is recommended to avoid overloading the reed contacts.

Valid regulations for hazardous areas, and regulations for installation (DIN/VDE 0165), should be observed when installing the NBK level indicator in zone 1 or 2 hazardous areas (no combustible liquids).

7.2. Remote sensor

Reed Contact Chain of Resistors (option ..W..)

- Ensure that the electrical supply lines are powerless.
- To avoid faults caused by electrical fields from other circuits, the cables should not be installed adjacent to other cables.
- Unscrew cover and run supply lines through cable gland.
- Connect the remote sensor to the electronics according to following table.

	Transmitter "top"	Transmitter "bottom"	Pick-off	
Silicon cable	white	brown	green	
PVC cable	white	brown	green	
FEP cable	brown	blue	black	
Adapter box	terminal 1	terminal 2	terminal 3	
Internal *	yellow	red	black	

***Please note: The colours of internal cables are for internal connections only and therefore are only visible in transmitters with connection box.**

When connecting remote sensors to a Kobold transmitter, for example models DFA, DST or DFM, please read the relevant operating instructions.

7.3. Remote Sensor: Chain of Resistors with 2-wire Transmitter (option ..M..)

- Ensure that the electrical supply lines are powerless.
- To avoid faults caused by electrical fields from other circuits, the cables should not be installed adjacent to other cables.
- Unscrew cover and run supply lines through cable gland.
- Connect the remote sensor to the electronics according to the wiring diagram below.

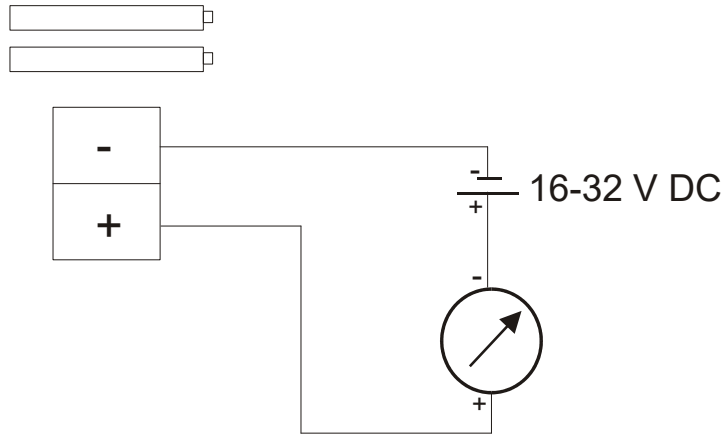

7.4. Remote Sensor: Magnetostrictive Sensor with 4-wire Transmitter (option ..T..)

- Ensure that the electrical supply lines are powerless.
- To avoid faults caused by electrical fields from other circuits, the cables should not be installed adjacent to other cables.
- Unscrew cover and run supply lines through cable gland.
- Connect the remote sensor to the electronics according to the wiring diagram below.

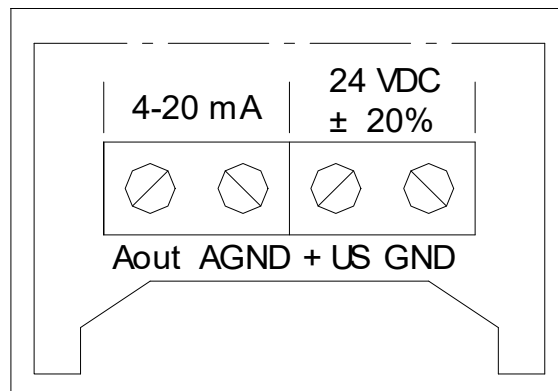

8. Commissioning

Because of the setting behaviour of seals, all screw connections must be retightened. Fill vessel, and switch on electrical controller, if existing. If there are stopcocks between bypass process connection and tank, first slowly open the upper valve (pressure relief) and then the lower valve (liquid side). If vent and drain valves have been installed, close them before filling.

The liquid that now enters the bypass tube raises the float until the level between tank and bypass tube is balanced. The roller indicator indicates the liquid level.

With the NBK-M for media density from 1.0 g/cm^3 , there is a guidewire in the lower process connection. This ensures the first filling or very low level to an optimized guidance of the float.

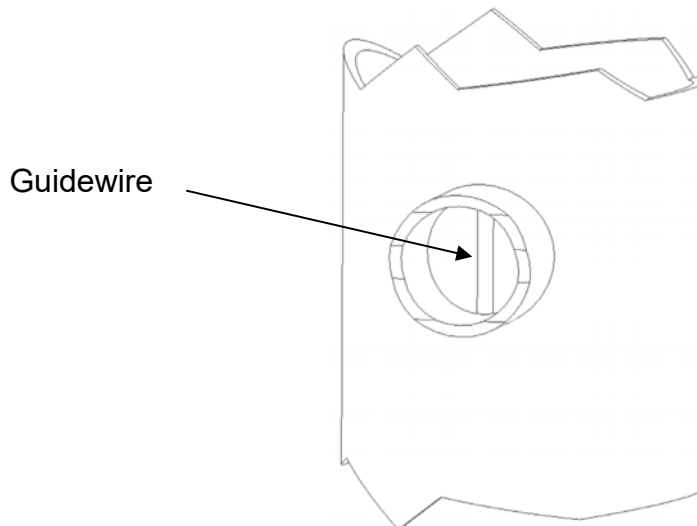

Commissioning Reed Switches

Function of switches

All switches have three connection poles (black (2), blue (1) and brown (3)). The black wire (2) is the common pole for both switching functions (N/C and N/O contact).

The float must pass the switch once in both directions so that the switching function is in line with the terminal connection diagram and table below.

These instructions are often ignored when an alarm lamp is connected with the result that the alarm lamp incorrectly indicates a fault.

When the switch has been passed over for once, it is ready for operation and requires no maintenance.

Note that the switch cable must point downwards.

	black (2) / blue (1)	black (2) / brown (3)
float above	open	electrical conductive
float below	electrical conductive	open

Hysteresis

Hysteresis is the difference between contact closing and opening points. A hysteresis of approximately 15 mm float travel is achieved by factory tuning of the float magnet and contact strength.

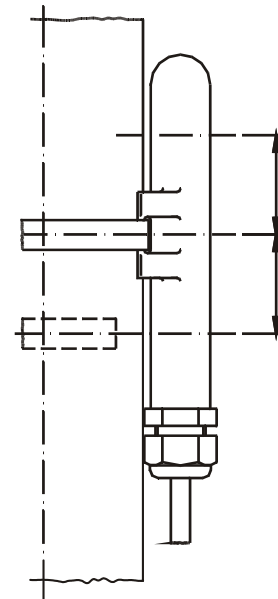

9. Trouble Shooting

Error: The tank is full but there is no indication

- Check that both flanges (process connection) top and bottom are open to the vessel, and that the bypass tube fills with liquid.
- Check that there is a float in the system.
- When the float is installed, check whether it is being blocked by foreign objects or dirt deposits.

Error: The tank is full but the indication is too low.

- Check that the density of the liquid is the same as the density given on the nameplate.
- Check that the float has been correctly installed with the marking "TOP" at the top.
- Check if dirt deposits in the bypass tube are blocking the float.

10. Maintenance

The drain plug should be opened occasionally, to wash out any deposits in case the liquid to be measured contains dirt particles, which could settle in the bypass tube. If encrustations or crystallisation have formed, the tank must be emptied or shut off; the lower cover flange must then be removed. The float should then be removed carefully from the vessel. The bypass tube can now be mechanically cleaned.

The inspection window for the roller indication is made of high-quality plexiglass (glass for high-temperature display). It should be cleaned with a suitable cleaning agent.

The indicator requires no further maintenance.

11. Technical Information

Bypass tube:	Ø 40 mm
Material:	1.4571
O-Ring (Ground flange):	NBR 70 (-30...+100 °C) (other materials as options)
Operating pressure:	PN 6/16/40 – 150 lbs / 300 lbs
Operating temperature:	to 120 °C PP rollers to 200 °C ceramic rollers
Viscosity:	max. 200 mm ² /s
Max. measuring length:	to 3000 mm one-piece
Total length:	according to measuring length, see dimension drawing
Float:	titanium, closed Special versions on request.

Limit contacts model NBK-R

Contact operation:	bistable changeover contact
Switching hysteresis:	approximately 15 mm
Max. switching capacity:	60 W/VA; 230 V _{AC/DC} , 1.0 A
Medium temperature:	max. 100 °C
Ambient temperature:	max. 75 °C
Protection:	IP 67
Connection:	3 m PVC cable
Case:	plastic

Limit contacts model NBK-RT200

Contact operation:	bistable changeover contact
Switching hysteresis:	approximately 15 mm
Max. switching capacity:	80 VA; 250 V _{AC/DC} ; 1A
Medium temperature:	max. 200 °C
Ambient temperature:	max. 145 °C
Protection:	IP 65
	die cast aluminium housing, terminal connection

Transmitter model: ...W...

Reed Contact Chain of Resistors

Total resistance:	approximately 5 kΩ
Measuring-voltage:	max. 24 V _{DC}
Measuring current:	max. 0.1 A
Medium temperature:	max. 200 °C
Ambient temperature:	max. 130 °C
Protection:	IP 65
Resolution:	10 mm (ML < 2000 mm) 20 mm (ML ≥ 2000 mm)

Transmitter model: ...M...

Reed Contact Chain of Resistors with 2-wire Transmitter

Output:	4-20 mA
Power supply:	16-32 V _{DC}
Load:	(U _B - 9 V) / 0.02 A [Ω]
Medium temperature:	max. 130 °C
Ambient temperature:	max. 80 °C
Protection:	IP 65
Resolution:	10 mm (ML < 2000 mm) 20 mm (ML ≥ 2000 mm)

Transmitter model: ...T...

Magnetostrictive Sensor with 4-wire Transmitter

Output:	4-20 mA / Load max. 500 Ω
Max. length:	3000 mm
Supply voltage:	24 V _{DC} , max. 150 mA
Accuracy:	± 1mm
Temperature range:	-20...+ 80 °C
Ambient temperature:	max. 80°C
Protection:	IP 65

12. Order Codes

Note: See KOBOLD USA Datasheet for USA Order Codes

Model	Nominal Pressure	Connection	Nominal Diameter	Roller Indicator	Measuring sensor	Medium density	Options
NBK-M	1= PN 6 (not with ASME flange) 2= PN 16 (150 lbs) 3= PN 40 (300 lbs)	F= DIN Flange A= ASME-Flange R= Tube thread N= NPT thread	10= DN 10 (only with DIN-flange) 15= DN 15, 1/2" 20= DN 20, 3/4" 25= DN 25, 1"	0= without P= PP roller K= ceramic roller	0= without T= magnetostrictive W= chain of resistors M= chain of resistors with transmitter	8= from 0.8 g/cm ³ 1= from 1.0 g/cm ³	0= without ...= (see list)
NBK-RM	Standard Limit Contact						
NBK-RT200M	High-temperature contact max. 200 °C						

13. Dimensions

NBK-M with roller indication

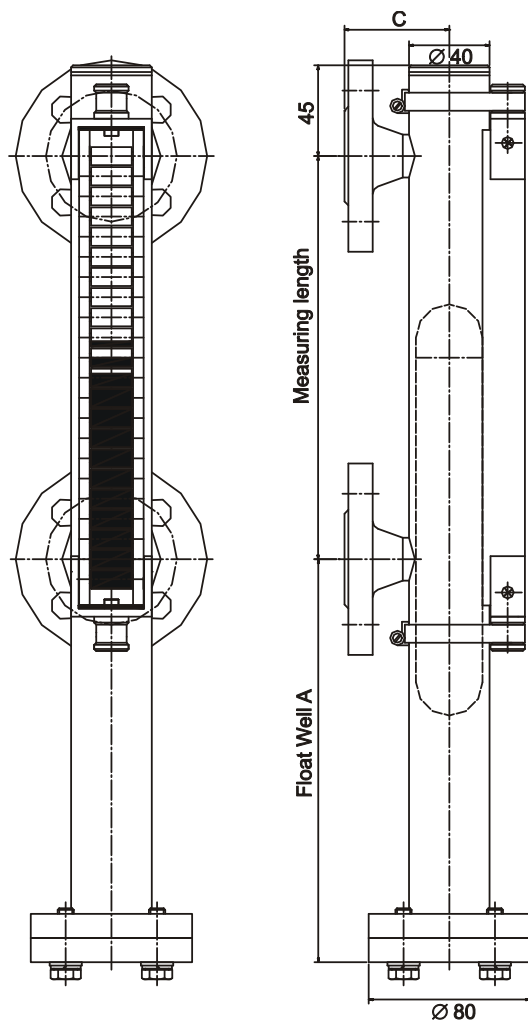

Dimension C [mm] for DIN V-flange

Model	DN 10	DN 15	DN 20	DN 25
PN 6	46	47	47	46
PN 16	53	52	53	49
PN 40	53	55	55	51

Dimension C [mm] for ANSI V-flange

Model	1/2"	3/4"	1"
150 lbs	64	67	66
300 lbs	69	72	73

Dimension C for R- or NPT thread: 60 mm

Dimension A: medium density 0,8 g/cm³: 290 mm
 medium density 1,0 g/cm³: 185 mm

NBK-M with roller indicator and magnetostrictive transmitter

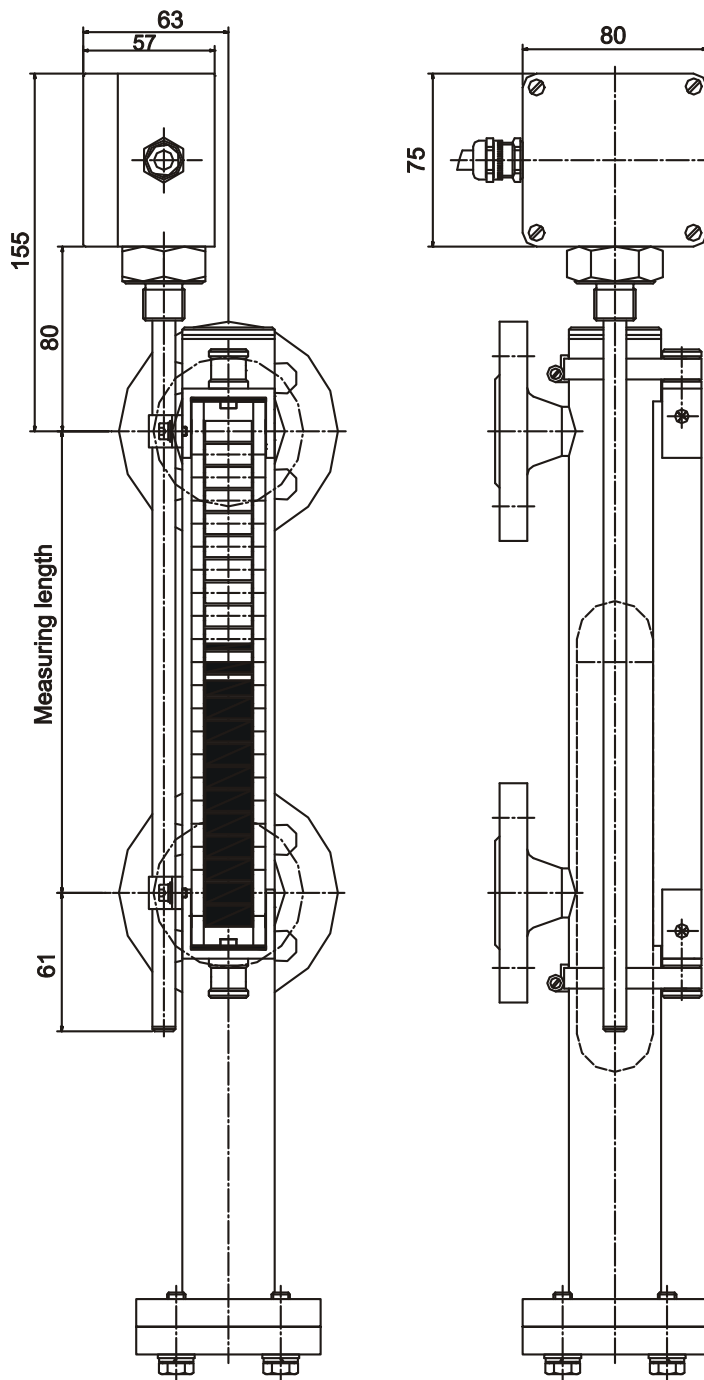

14. Options

- B Display model ADI-B with bar graph rugged aluminum housing, mounted on bypass tube, for description, see brochure Z2
- C Display model ADI-K with bar graph and digital display, rugged aluminum housing, mounted on bypass tube, for description, see brochure Z2
- D Display model ADI-D with digital display, rugged aluminum housing mounted on bypass tube for description, see brochure Z2
- E1 Drain flange DN 15, stainless steel 1.4571
- E2 Drain flange DN 20, stainless steel 1.4571
- E3 Drain flange, ASME 1/2", stainless steel 1.4571
- E4 Drain flange, ASME 3/4", stainless steel 1.4571
- L1 Drain valve G 1/4, stainless steel 1.4571
- L2 Drain valve 1/4 NPT, stainless steel 1.4571
- H1 Rinsing connection DN 15/PN 16, top and bottom
- H2 Rinsing connection ASME 1/2", 150 lbs, top and bottom
- M1 Measuring scale to 200°C, aluminum, engraved scale
- M2 Measuring scale to 120°C, aluminum, polyester foil scale
- P Radiographic examination DIN 54111 T1
- Q Dye penetration test DIN 541152
- X Pressure test with water 1.5 x PN
- Z 3.1 certificate as per EN 10204
- R1 Drain screw, bottom, G 1/4, PTFE gasket
- R2 Drain screw, bottom, 1/4 NPT, no gasket
- W1 O-ring material (bottom flange): FPM
- W2 O-ring material (bottom flange): silicone
- W3 O-ring material (bottom flange): PTFE
- W4 O-ring material (bottom flange): Kalrez/Chemraz

15. EU Declaration of Conformance

We, Kobold-Messring GmbH, Hofheim-Ts., Federal Republic of Germany, hereby declare that the bypass level indicators meet the following criteria.

The Mini Bypass Level Indicators with Limit Switches

model NBK-R
model NBK-RT

Conform to the standards listed below:

EN 61010-1:2011

Safety requirements for electrical equipment for measurement, control and laboratory use - Part 1: General requirements

EN 60529:2014

Degrees of protection provided by enclosures (IP Code)

The following Mini Bypass Level Indicators with Remote Sensors

model NBK-...M...
model NBK-...T...
model NBK-...W...

Conform to the standards listed below:

EN 61000-6-4:2011

Electromagnetic compatibility (EMC) - Part 6-4: Generic standards - Emission standard for industrial environments

EN 61000-6-2:2006

Electromagnetic compatibility (EMC) - Part 6-2: Generic standards - Immunity for industrial environments

EN 61010-1:2011

Safety requirements for electrical equipment for measurement, control and laboratory use - Part 1: General requirements

EN 60529:2014

Degrees of protection provided by enclosures (IP Code)

The following EU directives are fulfilled:

2014/35/EU **Low Voltage Directive**
2014/30/EU **Electromagnetic Compatibility Directive**
2011/65/EU **RoHS**
2015/863/EU **Delegated Directive (RoHS III)**



H. Peters
General Manager

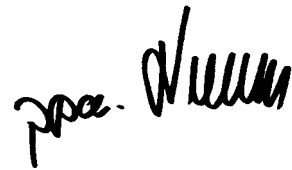

M. Wenzel
Proxy Holder

Hofheim, 14 Nov. 2019