

Operating Instructions for Air-Flow Monitor

Model: LPS-P



Order from: **C A Briggs Company**
622 Mary Street; Suite 101; Warminster, PA 18974
Phone: 267-673-8117 - Fax: 267-673-8118
Sales@cabriggs.com - www.cabriggs.com

1. Contents

1. Contents.....	2
2. Note	3
3. Regulation use	3
4. Operating Principle.....	3
5. Instrument Inspection.....	4
6. Mechanical connection.....	4
7. Electrical Connection	5
8. Commissioning.....	6
9. Technical Information.....	7
10. Order Codes	7
11. Maintenance	7
12. Dimensions	8
13. EU Declaration of Conformance.....	9

Manufactured and sold by:

Kobold Messring GmbH
Nordring 22-24
D-65719 Hofheim
Tel.: +49(0)6192-2990
Fax: +49(0)6192-23398
E-Mail: info.de@kobold.com
Internet: www.kobold.com

2. Note

Please read these operating instructions before unpacking and putting the unit into operation. Follow the instruction precisely as described herein.

The devices are only to be used, maintained and serviced by persons familiar with these operating instructions and in accordance with local regulations applying to Health & Safety and prevention of accidents.

By usage in machines, the measuring unit should be used only then when the machines fulfil the EC-machine guidelines.

3. Regulation use

These units (type LPS) are employed in order to monitor the air-flow in air and environment industry. All these units are equipped with adjustable limit-contacts. Monitoring of fluids is suitable only for those gases and air, which would not attack the materials used in flow monitor.

This air-flow monitor should not be used for monitoring of flammable and explosive gases.

Material Combination

Housing	Galvanised base-plate /Cover (ABS)
Paddle	St. Steel (AISI)
Paddle arm	Brass (Ms 58)
Connection- plate	Galvanised iron
Flat Gasket	Flexoid

Switch Off/On (adjustable)

Switch-off values (min) 1.5 m / sec.
(max) 8.0 m / sec. (with shortened paddle)

Switch-on values (min) 2.5 m / sec.
(max) 9.2 m / sec. (with shortened paddle)

4. Operating Principle

The air flow being controlled presses against the paddle, which is mechanically linked to a dust-tight changeover microswitch. The latter will signal whether or not the minimum or maximum preset air flow exists.

The switching point is adjustable over a wide range of values.

5. Instrument Inspection

Instruments are checked before dispatch and should arrive in perfect condition. In case of damage, please inform your local Kobold office or if you had the parcel transport your parcel service / forwarding agent immediately, since they are responsible for damages during transit. Should the damage to a device be visible, we recommend a thorough inspection of the delivery packing.

Scope of delivery:

- Air-Flow Monitor Model: LPS-P
- Flat Gasket
- Operating Instructions

6. Mechanical connection

Before mounting

- Please ensure that the actual flow value remains within the switching range of the unit.
- Make sure that the permitted max. operational pressure and temperature limits of this unit are not exceeded.
- Please ensure a minimum run inner pipe diameter of 5 x D upstream and downstream of the switch.

Assembly

- Drill a hole and a slit in your air-channel as shown in the adjacent drawing.
- Fix the flow-monitor over the air-channel and secure it with 4 metal screws (D=3.5 mm).
- The paddle can also be mounted after the installation, it is then sufficient to drill a 20 mm diameter hole.
- Sealing is carried out by means of supplied flat gasket.
- Mounting of this unit is position independent. The affixed arrow sign on housing must point in the direction of the flow. The upper part of the flow-monitor must be vertical with respect to the pipe axis. With vertical mounting, the switching point must be adjusted in order to compensate for the paddle-weight.
- For gases containing dust particles, the flow monitor must be positioned in such a way that no dust particles can deposit inside the connection head (e.g. mounting on the upper side of the air-channel).

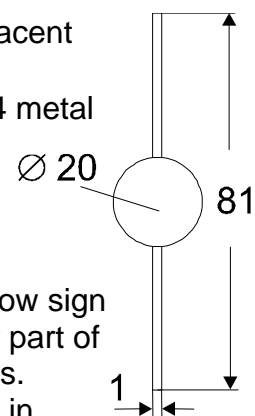

7. Electrical Connection

- Please ensure that the voltage *as well* as the current values of your power supply does not exceed the permitted values specified for the flow monitor.
- Before making connections, be assured that the power supply lines are not active.
- Remove the housing of the flow monitor by loosening
- 4 screws
- Make connections to the flow monitor as shown in the adjoining figure.

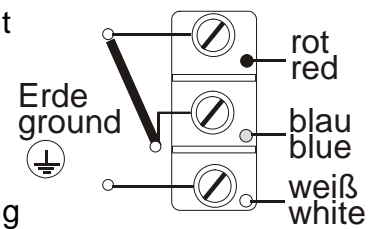

After making connections between external units and the limit-contact, the unit is ready for operation.

8. Commissioning

These units are supplied along with an adjustable micro-switch. The contact is change-over type, which, depending on connections, may be used as normally-closed or normally-open switch.

These units are factory-set at a switch-off value of 1.5 m / sec.

A higher "switch-off" value is set by rotating the range-screw in the clockwise direction.

In case a switching value over 5 m / sec. is desired, then the paddle must be truncated at the marked position.

By paddle-truncation, the factory-set value changes to 2.5 m/sec.

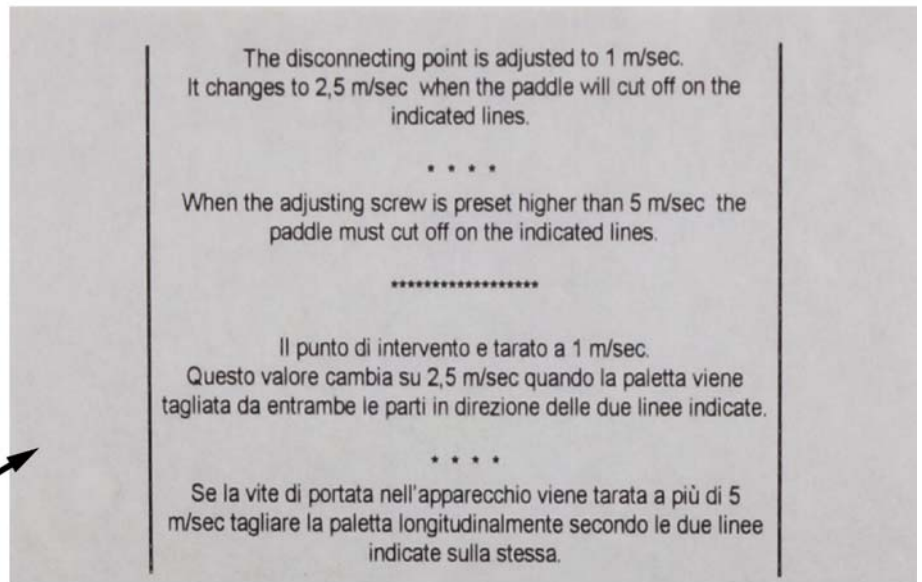

9. Technical Information

Max. Switching Current:	15 (8) A
Max. Switching Voltage:	24 - 250 VAC
Protection Cat.:	IP 65 (from external channel)
Max. Medium Temp.:	+85 °C
Ambient Temperature:	-40 °C ...+85 °C

10. Order Codes

Description	Order number
Air-flow indicator	LPS-1100P

11. Maintenance

In case, the medium to be measured is not polluted, LPS-P flow-monitor is regarded as maintenance-free. Otherwise, presence of large-size dust-particles may lead to the jamming of paddle arm. Depending upon the degree of pollution, a routine check after regular intervals is recommended.

12. Dimensions

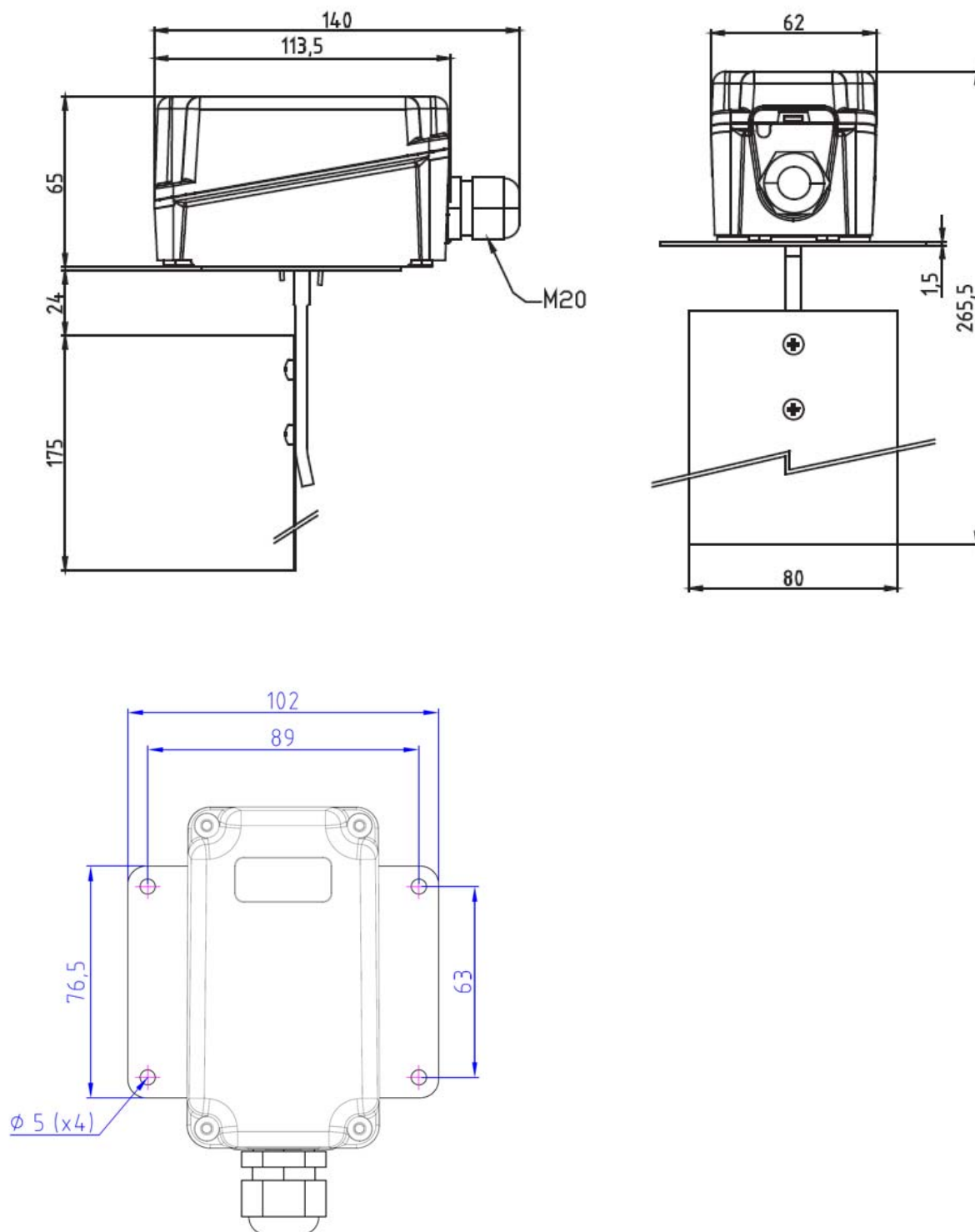

13. EU Declaration of Conformance

We, KOBOLD Messring GmbH, Hofheim-Ts, Germany, declare under our sole responsibility that the product:

Air-Flow Monitor Model: LPS-P

to which this declaration relates is in conformity with the standards noted below:

EN 60730-2-15:2010 Automatic electrical controls for household and similar use - Part 2-15: Particular requirements for automatic electrical air flow, water flow and water level sensing controls

Also the following EC guidelines are fulfilled:

2014/30/EU	EMC Directive
2014/35/EU	Low Voltage Directive
2011/65/EU	RoHS (category 9) industrial monitoring and control instruments, compliant, no CE-marking for the transitional period until 2017

Hofheim, 01. Dec. 2016

H. Peters
General Manager

M. Wenzel
Proxy Holder