

Operating Instructions for Plastic Flow Meter

Model: KSM



Order from: **C A Briggs Company**
622 Mary Street; Suite 101; Warminster, PA 18974
Phone: 267-673-8117 - Fax: 267-673-8118
Sales@cabriggs.com - www.cabriggs.com

1. Contents

1. Contents.....	2
2. Note	3
3. Regulation Use.....	3
4. Operating Principle.....	4
5. Instrument Inspection.....	4
6. Mechanical Connection.....	4
7. Electrical Connection	5
8. Operation	6
9. Technical Data	7
10. Order Codes	8
11. Maintenance	10
12. Dimensions	11
13. EU Declaration of Conformance.....	12

Manufactured and sold by: KOBOLD Instruments Inc.
1801 Parkway View Drive
Pittsburgh PA 15205-1422
Tel.: 412-788-2830
Fax: 412-788-4980
E-Mail: info@koboldusa.com
Internet: www.koboldusa.com

2. Note

Please read these operating instructions before unpacking and putting the unit into operation. Follow the instructions precisely as described herein.

The devices are only to be used, maintained and serviced by persons familiar with these operating instructions and in accordance with local regulations applying to Health & Safety and prevention of accidents.

When used in machines, the measuring unit should be used only when the machines fulfil the EC-machine guidelines.

PED 2014/68/EU

In acc. with Article 4 Paragraph (3), "Sound Engineering Practice", of the PED 2014/68/EU no CE mark.

	Pipe	
	Table 8 Group 1 dangerous fluids	Table 9 Group 2 no dangerous fluids
KSM-x001 – KSM-x010	Art. 4, § 3	Art. 4, § 3
KSM-x020 – KSM-x600	Kat. I	Art. 4, § 3

3. Regulation Use

Any use of the Plastic Flow Meter, model: KSM, which exceeds the manufacturer's specification, may invalidate its warranty. Therefore any resulting damage is not the responsibility of the manufacturer. The user assumes all risk for such usage.

4. Operating Principle

The Plastic Flow Meter model: KSM operates according to the variable area principle, in which the float is free to move without friction inside the measuring tube. The reading edge corresponds to the larger diameter of the float. The standard flow meter is equipped with a scale for water (+20°C), a percentage scale, O-rings, 2 adjustable set-point indicators and a rail for accessories; on each end, two threaded cap-screws accommodate various connectors (see Section 9: Technical Data; Connections). For the operation with bistable reed switches the float will be supplied with internal magnets.

5. Instrument Inspection

Instruments are inspected before shipping and sent out in perfect condition. Should damage to a device be visible, we recommend a thorough inspection of the delivery packaging. In case of damage, please inform your parcel service / forwarding agent immediately, since they are responsible for damages during transit.

Scope of delivery:

The standard delivery includes:

- Plastic Flow Meter model: KSM
- Operating Instructions

6. Mechanical Connection

Before Installation:

- Remove all transportation safety locks and ensure that no packing material remains within the unit.
- Be sure that the maximum allowable operating pressure and temperature is not exceeded (see Technical Data).
- Install the flow meter in the piping system, making certain the instrument is under no mechanical stress/tension (install support bracing if necessary).

- Protect the measuring tube from external damage.
- Avoid pressure peaks in the measuring tube, e.g. from sudden surges or stoppage of flow.
- The units with bistable reed switch may not be installed within an inductive field.
- If possible, immediately after making mechanical connections, check whether the connections are properly sealed with no evidence of leakage.

Detailed information regarding installation of float flow meters is available in VDI/VDE guidelines 3513.

7. Electrical Connection

Reed contact, bistable (option)

- Ensure that the electrical supply lines are disconnected from power.
- Loosen the plug-cap holding screw and remove the cap from the switch housing.
- Connect the supply lines inside the plug-cap in accordance with the connection diagram opposite.
- If the set point has not yet been adjusted, it may be done at this point. (see section 8, 'Operation').
- Set the plug to the socket and fix it with the safety screws.

N/O contact

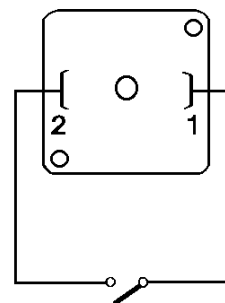

Attention! The stated electrical parameters of the reed switch may not be exceeded, even for a short period of time. For switching higher power ratings, we recommend a contact protection relay (e.g. our model MSR) or any other interposing relay.

After connecting the external devices, and adjusting the switch housing to the desired switch points, all the connection work is completed. The unit is ready for operation.

8. Operation

In order to initialise the bistable switching function, it is essential that the float-travel activates the contact once in each direction.

Adjustment of limit-values

The switch-point can be adjusted to the desired levels by using both red sliders as reference points.

Reference edge for falling flow: bottom-edge, switch housing

Reference edge for rising flow: approx. 5 mm above the bottom-edge of switch housing.

Slide the switch housing up or down until the reference edge coincides with the desired switch-point scale reading.

Hysteresis

Hysteresis is the difference between the level at which “switch-on” occurs during rising flow and the level at which “switch-off” occurs during decreasing flow. The hysteresis is approximately 5 mm on the float scale.

Overranging

With non-pulsating flow, the maximum flow rate can be exceeded. Only an increase in pressure loss will result (max. permissible operating pressure must not be exceeded!)

9. Technical Data

Housing:	KSM-1...: Trogamide-T (PA) KSM-2...: Polysulfone
Connections:	½" ... 3½", see order codes
Float:	PVDF
Guide rod:	PVDF/stainless steel for the three largest sizes
Seals:	EPDM (KSM-1.../KSM-2...) FPM (KSM-3...)
Max. temperature:	KSM-1...: 0-60 °C KSM-2...: 0-100 °C with contact: 85 °C
Max. pressure:	KSM-x0xx, KSM-x1xx: 16 bar KSM-x201, KSM-x301, KSM-x601: PN 10
Accuracy:	±4% F.S.
Repeatability:	≤1%

Reed contact (optional):

Bistable Reed contact (N/O) on rising flow

Max. ambient temperature: 0...55°C

Max. power: 230 V_{AC}; 10 W / 12 VA; 0.5 A

Hysteresis: approx. 3 ... 12 mm span

Protection: IP 65

(While upgrading a unit with contact, the float must be replaced by a float with integrated magnet.)

Connections (optional):

(only KSM-1... and KSM-2...)

Following connections are available with cap-screws:

- Glue-in connection made of PVC (max. 60°C; PN 10)
- Female thread made of PVC (max. 60°C; PN 10)
- Female thread made of cast iron

Respective connection sizes are listed in the tables in Section 10 "Ordering Information"

10. Order Codes

Note: See KOBOLD USA Datasheet for USA Order Codes

Medium liquids

The following scales are available for liquids

Model	Standard Water [L/h]	Pressure loss [mbar]	Special scale					
			Water [m³/h]	Water [L/s]	Water [L/min]	NaOH 30 % [L/h]	NaOH 50 % [L/h]	HCl* 30-33 % [L/h]
KSM-..001	15-150	19	-	-	0.25-2.5	3-46	0.5-7	20-130
KSM-..005	50-500	19	-	-	0.8-8	10-270	2.5-70	60-460
KSM-..010	100-1000	19	0.1-1	-	1.7-17	40-600	6-220	120-900
KSM-..020	200-2000	26	0.2-2	0.056-0.56	3.3-33	100-1400	20-600	200-1900
KSM-..030	300-3000	26	0.3-3	0.08-0.8	5-50	200-2000	50-1200	300-2700
KSM-..060	600-6000	26	0.6-6	0.17-1.7	10-100	400-4600	200-3400	800-5600
KSM-..120	1200-12000	26	1.2-12	0.34-3.4	20-200	800-8400	300-5600	1200-10000
KSM-..201	2000-20000	26	2.0-20	0.55-5.5	33-330	1400-15000	500-11000	2000-18000
KSM-..301	3000-30000	26	3.0-30	0.83-8.3	50-500	2000-20000	1000-14000	3000-25000
KSM-..601	8000-60000	34	8.0-60	-	-	-	-	-

* for KSM-2... and KSM-3... only

Order Details (Example: KSM-1005H K32 R1)

Measuring range water [L/h]	Order no. Trogamide	Order no. PSU	Scale	Option screwed fitting (for KSM-1..., KSM2...only)	Option contact
15 - 150	KSM-1001...	KSM-2001...	H= L/h water Q= m³/h water M= L/h water min S= L/h water s	000 = without auxiliary screwed fitting K32= glue-in connection Da32 (PCV) P15= PVC G 1/2 IG P20= PVC G 3/4 IG P25= PVC G 1 IG T25= malleable cast iron G 1 IG V32= PVDF (Welding sleeve) Da32 F25= PVC flange DN 25	R0= without contact R1= 1 contact R2= 2 contacts
50 - 500	KSM-1005...	KSM-2005...			
100 - 1000	KSM-1010...	KSM-2010...			
200 - 2000	KSM-1020...	KSM-2020...	H= L/h water Q= m³/h water M= L/h water min S= L/h water s	000= without auxiliary screwed fitting K50= glue-in connection Da50 (PVC) P25= PVC G 1 IG P32= PVC G 1 1/4 IG P40= PVC G 1 1/2 IG T40= malleable cast iron G 1 1/2 IG V50= PVDF (Welding sleeve) Da50 F40= PVC flange DN 40	R0= without contact R1= 1 contact R2= 2 contacts
300 - 3000	KSM-1030...	KSM-2030...			
600 - 6000	KSM-1060...	KSM-2060...	H= L/h water Q= m³/h water M= L/h water min S= L/h water s	000= without auxiliary screwed fitting K63= glue-in connection Da63 (PVC) P25= PVC G 1 IG P40= PVC G 1 1/2 IG P50= PVC G 2 IG T50= malleable cast iron G 2 IG V63= PVDF (Welding sleeve)Da63 F50= PVC flange DN 50	R0= without contact R1= 1 contact R2= 2 contacts
1200 - 12000	KSM-1120...	KSM-2120...			
2000 - 20000	KSM-1201...	KSM-2201...	H= L/h water Q= m³/h water M= L/h water min S= L/h water s	000= without auxiliary screwed fitting K75= glue-in connection Da75(PVC) P40= PVC G 1 1/2 IG P50= PVC G 2 IG T65= malleable cast iron G 2 1/2 IG V75= PVDF (Welding sleeve) Da75 F65= PVC flange DN 65	R0= without contact
3000 - 30000	KSM-1301...	KSM-2301...			
8000 - 60000	KSM-1601...	KSM-2601...			

Medium air

The following scales are available for air

Typ	m ³ /h (0 bar rel.)	m ³ /h (1 bar rel.)	m ³ /h (2 bar rel.)	m ³ /h (3 bar rel.)	m ³ /h (4 bar rel.)	m ³ /h (5 bar rel.)	m ³ /h (6 bar rel.)	m ³ /h (7 bar rel.)	m ³ /h (8 bar rel.)
KSM-.001	0.8 - 5	1.2 - 7	1.4 - 9	1.6 - 10	2 - 12	2 - 13	2 - 14	2.5 - 14	2.5 - 15
KSM-.005	2 - 18	3 - 25	4 - 30	5 - 35	5 - 40	6 - 43	6 - 45	7 - 50	6 - 52
KSM-.010	4 - 34	6 - 50	8 - 60	8 - 70	10 - 74	10 - 84	10 - 90	12 - 96	12 - 100
KSM-.020	10 - 70	12 - 90	14 - 120	15 - 130	20 - 150	20 - 160	20 - 170	20 - 190	20 - 200
KSM-.030	10 - 90	15 - 130	20 - 160	20 - 190	25 - 210	25 - 230	30 - 250	30 - 260	30 - 280
KSM-.060	22 - 190	30 - 260	40 - 380	40 - 400	50 - 450	50 - 480	75 - 500	70 - 550	75 - 550
KSM-.120	45 - 370	60 - 520	80 - 660	100 - 760	100 - 840	100 - 900	100 - 1000	120 - 1000	140 - 1100
KSM-.201	60 - 580	90 - 800	100 - 1060	120 - 1200	150 - 1300	150 - 1500	150 - 1500	200 - 1700	200 - 1800
KSM-.301	100 - 860	140 - 1200	200 - 1500	200 - 1700	250 - 1900	250 - 2100	300 - 2200	300 - 2400	300 - 2500

Order Details (Example: KSM-1010 2 P15 R0)

Meas. range air m ³ /h (0 bar rel.)	Order no. Trogamide	Order no. PSU	Scale Range see Table	Option screwed fitting	Option contact
0.8 - 5	KSM-1001...	KSM-2001...		000 = without auxiliary screwed fitting K32 = glue-in connection Da32 (PVC) P15 = PVC G 1/2 IG P20 = PVC G 3/4 IG P25 = PVC G 1 IG T25 = malleable cast iron G 1 IG V32 = PVDF (Welding sleeve) Da32 F25 = PVC flange DN 25	R0 = without contact R1 = 1 contact R2 = 2 contacts
2 - 18	KSM-1005...	KSM-2005...			
4 - 34	KSM-1010...	KSM-2010...			
10 - 70	KSM-1020...	KSM-2020...	0 = 0 bar rel. 1 = 1 bar rel. 2 = 2 bar rel.	000 = without auxiliary screwed fitting K50 = glue in connection Da50 (PVC) P25 = PVC G 1 IG P32 = PVC G 1 1/4 IG P40 = PVC G 1 1/2 IG T40 = malleable cast iron G 1 1/2 IG V50 = PVDF (Welding sleeve) Da50 F40 = PVC flange DN 40	R0 = without contact R1 = 1 contact R2 = 2 contacts
10 - 90	KSM-1030...	KSM-2030...	3 = 3 bar rel. 4 = 4 bar rel.		
22 - 190	KSM-1060...	KSM-2060...	5 = 5 bar rel. 6 = 6 bar rel.	000 = without auxiliary screwed fitting K63 = glue in connection Da63 (PVC) P25 = PVC G 1 IG P40 = PVC G 1 1/2 IG P50 = PVC G 2 IG T50 = malleable cast iron G 2 IG V63 = PVDF (Welding sleeve) Da63 F50 = PVC flange DN 50	R0 = without contact R1 = 1 contact R2 = 2 contacts
45 - 370	KSM-1120...	KSM-2120...	7 = 7 bar rel. 8 = 8 bar rel.		
55 - 545	KSM-1201...	KSM-2201...		000 = without auxiliary screwed fitting K75 = glue in connection Da75 (PVC) P40 = PVC G 1 1/2 IG P50 = PVC G 2 IG T65 = malleable cast iron G 2 1/2 IG V75 = PVDF (Welding sleeve) Da75 F65 = PVC flange DN 65	R0 = without contact
80 - 758	KSM-1301...	KSM-2301...			

11. Maintenance

If the medium to be measured is clean, the series KSM is virtually maintenance-free. If deposits form on the inner housing or parts, periodic cleaning of the unit is recommended. Remove the units from the piping with a suitable tool; clean the flow meter with a suitable cleaning agent or make use of an ultrasonic bath.

If using the setpoint switch, it is particularly important to guard against contamination by ferritic (metal) contaminants. These can be eliminated by using the KOBOLD model MF magnetic filter (or equivalent).

12. Dimensions

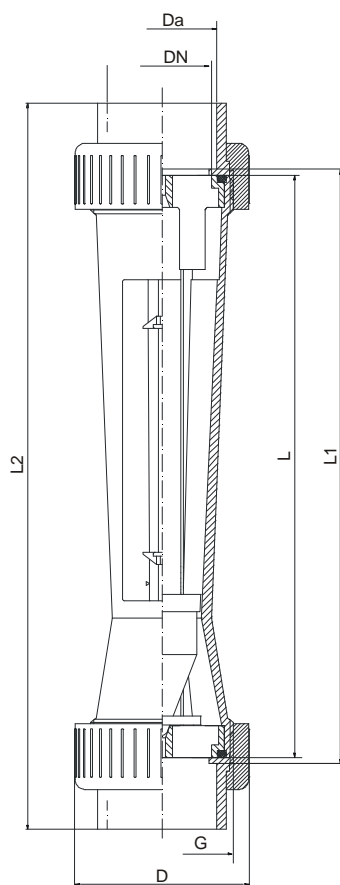

Model	DN	G	Da [mm]	L [mm]	L1 [mm] approx.	L2 (mm) approx.									D [mm] approx.
						Annealed- cast-iron	Glue conn.	PVC G 1/2	PVC G 3/4	PVC G 1	PVC G1 1/4	PVC G 1 1/2	PVC G 2	PVDF welded	
KSM-..001	25	R 1 1/2	32	335	341	390	385	432	441	480	--	--	--	385	60
KSM-..005	25	R 1 1/2	32	335	341	390	385	432	441	480	--	--	--	385	60
KSM-..010	25	R 1 1/2	32	335	341	390	385	432	441	480	--	--	--	385	60
KSM-..020	40	R 2 1/4	50	335	341	401	403	--	--	467	477	525	--	403	83
KSM-..030	40	R 2 1/4	50	335	341	401	403	--	--	467	477	525	--	403	83
KSM-..060	50	R 2 1/4	63	335	341	411	417	--	--	482	--	498	558	417	103
KSM-..120	50	R 2 3/4	63	335	341	411	417	--	--	482	--	498	558	417	103
KSM-..201	65	R 2 3/4	75	335	342	412	457	--	--	--	--	510	570	429	122
KSM-..301	65	R 3 1/2	75	335	342	412	457	--	--	--	--	510	570	429	122
KSM-..601	65	R 3 1/2	75	335	342	412	457	--	--	--	--	510	570	--	122

13. EU Declaration of Conformance

We, KOBOLD-Messring GmbH, Hofheim-Ts, Germany, declare under our sole responsibility that the product:

Plastic Flow Meter with Contact Model: KSM -...R1/R2

to which this declaration relates is in conformity with the standards noted below:

EN 61010-1:2011

Safety regulations for electrical measurement, control, regulation and Laboratory equipment

EN 60529:2014

Protection through housing (IP-Code)

EN 50581:2012 Technical documentation for the assessment of electrical and electronic products with respect to the restriction of hazardous substances

Also the following EC guidelines are fulfilled:

2014/35/EU **Low Voltage Directive**
2011/65/EU **RoHS** (category 9)

2014/68/EU **PED**

- Category III (IV) Diagram 1, vessel, group 1 dangerous fluids
- Module D, marking CE0575
- Notified body: DNV GL
- Certificate No. PEDD000000R



H. Peters
General Manager

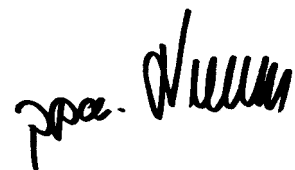

M. Wenzel
Proxy Holder

Hofheim, 02. Aug. 2018