

Operating Instruction
for
Calorimetric Flow Monitoring Device

Model: KAL



Order from: **C A Briggs Company**
622 Mary Street; Suite 101; Warminster, PA 18974
Phone: 267-673-8117 - Fax: 267-673-8118
Sales@cabriggs.com - www.cabriggs.com

1. Contents

1. Contents.....	2
2. Note	3
3. Instrument Inspection.....	3
4. Regulated Use	4
5. Operating Principle.....	5
6. Mechanical Connection.....	5
7. Electrical Connection	6
8. Limiting Contacts.....	6
9. Alignment / Balancing	7
10. Commissioning.....	10
11. Maintenance	10
12. Fault Signalling.....	11
13. Technical Information.....	11
14. Order Codes	13
15. Dimensions	14
16. EU Declaration of Conformance.....	15

Manufactured and sold by:

Kobold Messring GmbH
Nordring 22-24
D-65719 Hofheim
Tel.: +49(0)6192-2990
Fax: +49(0)6192-23398
E-Mail: info.de@kobold.com
Internet: www.kobold.com

2. Note

Please read and take note of these operating instructions before unpacking and setting the unit for operation, and follow the instructions precisely as described herein.

The devices are only to be used, maintained and serviced by persons familiar with these operating instructions and with the prevailing regulation applying to procedural safety and the prevention of accidents.

By usage in machines, the measuring unit should be used only then when the machines fulfil the EC-machine guide lines.

**PED 2014/68/EU
for KAL-11.. and KAL-12..**

In acc. with Article 4 Paragraph (3), "Sound Engineering Practice", of the PED 2014/68/EU no CE mark.

Table 8, Pipe, Group 1 dangerous fluids

3. Instrument Inspection

These devices are checked before dispatch and sent away in perfect condition. Should the damage to a device be visible, we recommend a thorough inspection of the delivery packing. In case of damage, please inform your parcel service/ forwarding agent immediately, since they are responsible for damages during transit.

Scope of delivery:

- probe with 2 m PVC as standard
- Electronic setting system
- Operating instructions

4. Regulated Use

The KAL is to be installed only in the specified applications. Every usage which exceeds the specifications is considered to be non-specified. Any damages resulting therefrom are not the responsibility of the manufacturer. The user assumes all risk for such usage. The application specifications include the installation, start-up and service requirements specified by the manufacturer.

Devices from the KAL model series are used for the monitoring of liquid flow.

Limiting relay

The devices are equipped with limiting relays for monitoring the flow speed of liquids (KAL-E1...-E3).

Trend display

An LED bar display shows the current flow value and the set switch point via a flashing LED (only on models KAL-E2... and KAL-E3...).

Probes

Probes are available in two options: as a screw-type or in-line version.

Model KAL devices are always made up of two structural components

- Probe
- Electronic setting system

The devices may only be used for liquids to which the probe housing materials are resistant. With proper installation and maintenance, the probes display no sensitivity to soiling and cause practically no pressure loss.

Materials

KAL-11...	Brass material
KAL-12..., KAL-23..., KAL-53...	St. steel material 1.4301
KAL-24..., KAL-54...	St. steel material 1.4571

Setting ranges in relation to nominal tube diameter

ND (mm)	Range (L/min) water	ND (mm)	Range (L/min.) water
8	0,12 - 6,0	40	3,0 - 150
10	0,19 - 9,4	50	4,7 - 235
15	0,42 - 21,8	60	6,8 - 340
20	0,75 - 37,7	80	12,0 - 603
25	1,18 - 59,0	100	18,8 - 942
30	1,7 - 84,8	150	42,4 - 2120



Attention! For the measuring ranges gives the flow speed was converted to the nominal tube diameter. It should be noted in line with this that in the tube towards the wall section the flow speed approaches 0. Depending on nominal tube diameter, screw depth of the probe and flow profile, occasional deviations, some of them considerable, may result.

5. Operating Principle

The all-metal design electronic flow monitor device functions according to proven calorimetric principles. The measuring probe is heated up a few degrees from the inside outwards in relation to the flow medium which it is penetrating. If the medium is flowing then the heat produced in the probe is carried away by the medium, i.e. the probe becomes cooler. This cooling represents a measuring of the flow speed.

The electronic setting system compares the desired flow speed with the actual speed and activates an output relay when the desired value is not reached. By the use of a micro-controller, simple calibrations are made possible. In this way optimum temperature compensation can be achieved.

6. Mechanical Connection

Before installation:

- Ensure that the actual flow quantity corresponds to the setting range of the device (i.e. to the flow speed).
- Ensure that the permitted maximum operating pressure and temperatures for the device are not being exceeded. (See point 13 Technical Information)

Installation:

Mount the sensor in the pipe (KAL-1...)- in a sleeve welded to the pipe (KAL-2...).

Fitting position:

The function of the sensor is not dependent on their fitting position, provided that the pipe is completely filled with flow medium. The place where the sensor is fitted must be free from turbulence in the medium. (4x pipe section in front of and behind sensor). If the medium is likely to cause any deposits in the tube, then an appropriate fitting position alongside is recommended.

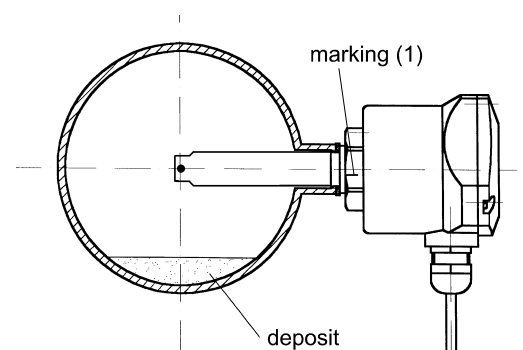

7. Electrical Connection



Warning! Ensure that the voltage values of your installation correspond to the voltage values given on the device's specification plate.

- Make sure that the electrical power supply is off.
- Connect the sensor cable to terminals 6 & 8 on the setting system.
- Connect the power supply (voltage supply) to terminals 15 & 16.

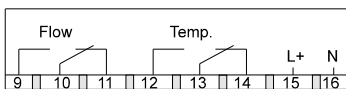
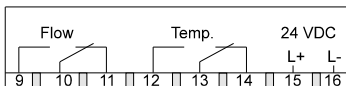
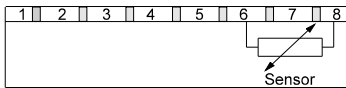

**Temperature relay only on models KAL-E3.
The relays are illustrated in fallen state.**

AC voltage supply
220 VAC, 110 VAC, 24 VAC +/- 10%, 50-60 Hz

DC voltage supply
24 VDC + 15%, - 10%

8. Limiting Contacts

Only on KAL-E1.../KAL-E2...

1x change - over relay for flow speed

Only on KAL-E3...

1x change - over relay for flow speed

1x change - over relay for temperature

9. Alignment / Balancing

Initial operation:

- 9.1. Fit sensor in pipe (ensure correct fitting location, see point 6 Mechanical Connection).
- 9.2. Connection sensor cables to electronic circuitry (see point 7 Electrical Connection).
- 9.3. Fill pipe with flow medium.



Caution! There must be no air bubbles on the sensor. Flow speed must be at 0.

- 9.4. Commission electronic circuitry (switch on supply voltage)
- 9.5. Only on model KAL-E-3...Set temperature potentiometer (2) to left-hand stop.
- 9.6. Zero point alignment. Briefly activate the "SET"key (5) (using a suitable object e.g. ball point pen)
- 9.7. "Flow" LED (6) flashes for about 30 seconds. After this time the "Flow"LED goes off (6). The device is now operational, continue with point 9.9.
- 9.8. In case of malfunction the "Flow" LED flashes continuously. Press the"SET" key once again. Device will switch back into measuring mode. Check mechanical and electrical installation and recommence operational procedure from point 9.4.
- 9.9. Switches on installation and set maximal flow.

If the flow speed is significantly less than 2 m/s, then on the trend display (3) there will be possibly fewer than 8 LEDs on.

It is now possible to extend this display (3) to the full range (8 LEDs). This can only be successfully achieved, however, if the flow speed is somewhere between 0.25-1.8 m/s.

- Set "Flow" potentiometer (1) (see illustration) to right-hand stop (only on KAL-E3...; Set temperature potentiometer to left-hand stop)
- Briefly activate SET key (5)
- Flow LED (6) will flash for 30 seconds. After this time the Flow LED will go 30 off.

It is possible at any time to reset the electronic circuitry to the full range

- Flow potentiometer (1) at right-hand stop
- (Only on KAL E3; Temperature potentiometer (2) to left hand-stop)
- Press the SET key (5) and hold in position until the FLOW LED stops

The device has now been reset into basic functioning mode.

The device is now adjusted to your medium. You can now set your switch point. (In case of malfunction see point 9.8)

9.10. Set operational flow.

Switch point setting: Model KAL-E-1...

- The further the Flow-potentiometer (1) is turned to the left, the lower the switch point.
- The further the Flow-potentiometer (1) is turned to the right, the higher the switch point.

Switch point setting: Model KAL-E-2.../E-3...

- Set Flow-potentiometer (1) to left-hand stop. The first LED on the luminous display (3) will flash. Any number of LED's on the luminous display will be continuously illuminated.
- Turn "Flow" potentiometer (1) to the right until the desired switch point is reached. The current switch point will be displayed by a flashing LED.

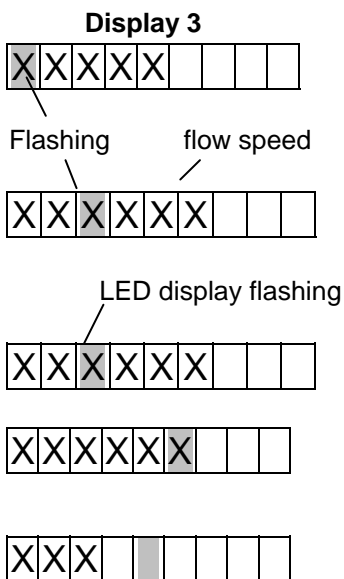

Explanation	Result
flow > switch point	Flow relay pick-up made Flow LED illuminated
flow > switch point LED flashes at double frequency	Flow relay pick-up made Flow LED illuminated
Flow < switch point	Flow LED off Flow relay open

Only KAL-E-3...

With more than 10 m cable between sensor and electronic circuitry, as well as increased accuracy when measuring temperature.

Temperature alignment

- Caution! Disconnect from power supply.
- Connect full length extension cable (>10 m) (terminals 6&8)
- Connect 100 Ohm $\pm 1\%$ resistor (part of delivery package) in place of sensor at the end of the instrument leads.
- Set temperature potentiometer (2) at 80° C (right - hand stop).
- Reconnect power supply and switch device on.
- Briefly press SET key (5).
- The temperature LED will flash and switch off again after approx. 10 seconds. In case of malfunction, see point 9.8, Initial operation. If the temperature LED flashes more quickly, this could be caused by the fact that the probe is connected instead of a 10 Ohm resistor.
- Remove the 100 Ohm resistor and replace the sensor.

10. Commissioning

The use of this meter in machines acc. to directive 89/392/EWG is prohibited until the complete machine complies to this directive.

Illustration KAL- E3 ...

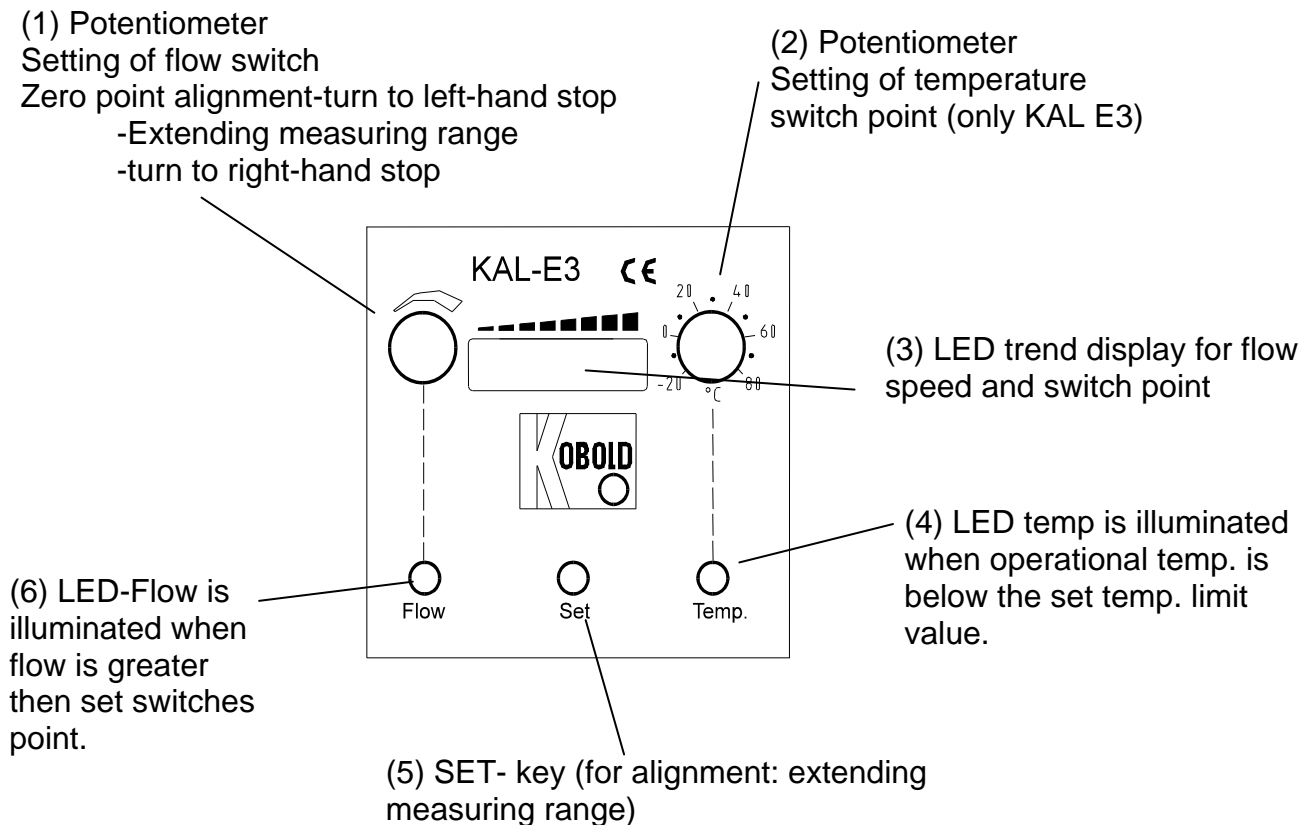

11. Maintenance

The device requires no maintenance. The sensor should be checked at monthly intervals for deposits (lime scale etc.) and cleaned where necessary.

12. Fault Signalling

When the alarm functions, the flow relay is released.

This happens in the following cases:

- Actual value < Desired value
- Short - circuit
- Line break
- Power failure

13. Technical Information

Sensor

Material:	case: see order details cable: PVC option (KAL-...HT): silicone cable gland: brass nickel-plated, Pg 7
Cable:	2 x 0.56 mm ² , length = 2 m max. line length: 100 m
Switching range:	4 cm/s ... 200 cm/s
Medium temperature:	-20 °C...+80 °C, Option (KAL-...HT): 0 °C...+120 °C
Ambient temperature:	-20 °C...+80 °C, KAL...-HT: 0 °C...+120 °C
Max. pressure:	100 bar



Caution! KAL 1132 and 1140 max. 25 bar

Protection:

IP 68

Electronic system

Power input:	max. 3.6 W
Switch capacity:	max. 250 V, max 3 A
Switch point adjustment:	with potentiometer
Switching function:	changeover, on rising flow (terminal 9 & 10 closed)
Option (KAL-E3.):	changeover, on rising temperature below setpoint, LED is energized (terminals 12&13 closed)
Output:	changeover relay
Output indicator:	with LED
Warm up time:	max. 12 s
Temperature range:	-20... +80 °C
Accuracy:	temperature limit value $\pm 2\%$
Repeatability:	approx. 2%
Response time:	5...12 s (typically)
DIN rail fitting:	DIN EN 50022 and DIN 46277
Protection:	case: IP 40, terminals: IP 20
Case:	polycarbonate, L 75 x W 55 x H 110 mm
Sensor output:	Short-circuit proof, cable break is detected as flow stoppage
Power failure:	calibration data are stored without battery for 10 years

14. Order Codes

Sensor order details (example: KAL-1308 HT)

	Connection	Order numbers				Electrical connection/ version
		Sensor with insertion fitting		Sensor with inline fitting		
		1.4301	1.4571	Fitting brass / Sensor 1.4301	Fitting 1.4301/ Sensor 1.4301	
G 1/4	KAL-1308	KAL-1408	KAL-1108	KAL-1208	00=2 m PVC cable HT=2 m Silicone cable YP=PVC cable/ special length YS=Silicone cable/ special length YY=Special cable/ special length	
G 3/8	-	-	KAL-1110	KAL-1210		
G 1/2	KAL-1315	KAL-1415	KAL-1115	KAL-1215		
G 3/4	KAL-1320	KAL-1420	KAL-1120	KAL-1220		
G 1	-	-	KAL-1125	KAL-1225		
G 1 1/4	-	-	KAL-1132	KAL-1232		
G 1 1/2	-	-	KAL-1140	KAL-1240		
M 12 x 1	KAL-0312	-	-	-		
1/4" NPT	KAL-5308	KAL-5408	KAL-5108	KAL-5208		
3/8" NPT	-	-	KAL-5110	KAL-5210		
1/2" NPT	KAL-5315	KAL-5415	KAL-5115	KAL-5215		
3/4" NPT	KAL-5320	KAL-5420	KAL-5120	KAL-5220		

Electronics order details (example: KAL-E10 (standard) or KAL-EH10 (version for high temperature))

	Field of application	Flow trend indication	Temperature monitoring	Supply voltage			
				24 V _{DC}	24 V _{AC}	110 V _{AC}	230 V _{AC}
				Flow	-	-	KAL-E13
KAL-EH13	KAL-EH12	KAL-EH11	KAL-EH10				
Flow	8-LEDs	-	KAL-E23	KAL-E22	KAL-E21	KAL-E20	
			KAL-EH23	KAL-EH22	KAL-EH21	KAL-EH20	
Flow/ Temperature	8-LEDs	-20...+80°C	KAL-E33	KAL-E32	KAL-E31	KAL-E30	
		0...+120°C	KAL-EH33	KAL-EH32	KAL-EH31	KAL-EH30	

15. Dimensions

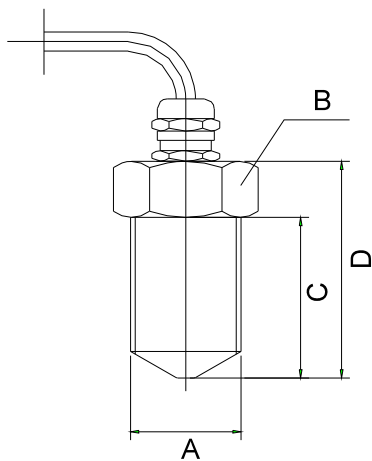

A	B	C [mm]	D [mm]
M12x1	SW 19	23	43
G 1/4	SW 19	26	43
G 1/2	SW 27	43	58
G 3/4	SW 32	43	58

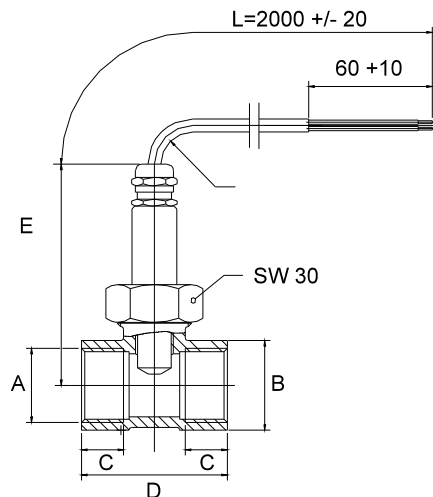

A	B	C [mm]	D [mm]	E [mm]
G 1/4	SW 27	10	50	81
G 3/8	SW 27	10	50	81
G 1/2	SW 27	10	50	81
G 3/4	SW 32	15	52	82,5
G 1	SW 39	15	56	85
G 1 1/4	SW 46	15	50	90
G 1 1/2	SW 55	15	50	92,5

16. EU Declaration of Conformance

We, KOBOLD-Messring GmbH, Hofheim-Ts, Germany, declare under our sole responsibility that the product:

KAL-E1... KAL-E3 Calorimetric flow monitoring device

to which this declaration relates is in conformity with the standards noted below:

EN 61000-6-3:2011

Electromagnetic compatibility (EMC) - Part 6-3: Generic standards - Emission standard for residential, commercial and light-industrial environments

EN 61000-6-2:2006

Electromagnetic compatibility (EMC) - Part 6-2: Generic standards - Immunity for industrial environments

EN 61010-1:2011

Safety requirements for electrical equipment for measurement, control and laboratory use - Part 1: General requirements

Also the following EC guidelines are fulfilled:

2014/30/EU

EMC Directive

2014/35/EU

Low Voltage Directive

2011/65/EU

RoHS (category 9)

Hofheim, 05. April 2016



H. Peters
General Manager



M. Wenzel
Proxy Holder