

Operating Instructions for Paddle Bellows Flow Monitor

Model: FPS-P...



Order from: **C A Briggs Company**
622 Mary Street; Suite 101; Warminster, PA 18974
Phone: 267-673-8117 - Fax: 267-673-8118
Sales@cabriggs.com - www.cabriggs.com

1. Contents

1. Contents.....	2
2. Note	3
3. Instrument Inspection.....	3
4. Regulation Use.....	4
5. Operating Principle.....	5
6. Mechanical Connection.....	5
7. Electrical Connection	6
8. Setting the Limit Contact	6
9. Maintenance	7
10. Technical Information.....	7
11. Order Codes	8
12. Dimensions	9
13. EU Declaration of Conformance.....	10

Manufactured and sold by: KOBOLD Instruments Inc.
1801 Parkway View Drive
Pittsburgh PA 15205-1422
Tel.: 412-788-2830
Fax: 412-788-4980
E-Mail: info@koboldusa.com
Internet: www.koboldusa.com

2. Note

Please read these operating instructions before unpacking and putting the unit into operation. Follow the instructions precisely as described herein.

The devices are only to be used, maintained and serviced by persons familiar with these operating instructions and in accordance with local regulations applying to Health & Safety and prevention of accidents.

When used in machines, the measuring unit should be used only when the machines fulfil the EC-machine guidelines.

**as per PED 2014/68/EU
for FPS-11**

In acc. with Article 4 Paragraph (3), "Sound Engineering Practice", of the PED 2014/68/EU no CE mark.

Diagram 8, Pipe, Group 1 dangerous fluids

3. Instrument Inspection

Instruments are inspected before shipping and sent out in perfect condition.

Should damage to a device be visible, we recommend a thorough inspection of the delivery packaging. In case of damage, please inform your parcel service / forwarding agent immediately, since they are responsible for damages during transit.

Scope of delivery:

The standard delivery includes:

- Flow Monitor Model: FPS
- Operating Instructions

4. Regulation Use

The model FPS is installed for monitoring flow of liquid medias in pipes with diameter between 1" and 8".

The instrument is provided with an adjustable limit switch.

Only media which does not affect the materials of construction can be used in the instrument. This device shall not be used in hazardous areas or for flammable liquids.

Material-combinations

	FPS-1115 P, FPS-1120 P	FPS-2100 P / FPS-3100 P FPS-5100 P / FPS-6100 P	FPS-2200 P / FPS-3200 P FPS-5200 P / FPS-6200 P
Housing:	Basic plate zinc plated / cover ABS		
Paddle:	st. steel		
Lever Arm	brass Ms 58	brass Ms 58	st. steel AISI 316 L
Connection	brass Ms 58	brass Ms 58	st. steel AISI 316 L
T-Piece	cast iron	---	---

5. Operating Principle

The KOBOLD flow monitor FPS operates according to the proven paddle bellows principle. The flowing medium acts on the paddle thus actuating a microswitch. Switching point can be freely adjusted and the device mated to different nominal pipe sizes by means of the replaceable paddle in conjunction with the additional adjustment features. The electrical device section is separated hermetically from the process fluid by means of a bellows.

The Special Switching Range version of the flow monitor has been designed for minimum switching values. See table in Section 11 Order Codes, for switching values. The devices can be installed in any position.

6. Mechanical Connection

Before installation

- Please ensure whether the actual flow matches the switching range of the instrument
- Please ensure whether the allowable maximum operating pressure and operating temperature of the instruments will not be exceeded.
- Please ensure a straight run of 5 x pipe diameters at inlet and outlet is being used.

Installation

- Select the paddle to suit the pipe internal diameter. To ensure stability the shorter paddle should always be left on. Make sure that the paddle can move freely in the pipeline and that it does not stick to the pipe wall.

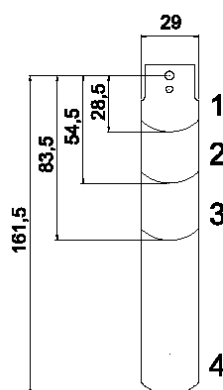

PADDLES (models without "T" pipe fitting)	
PIPE	PADDLES
1"	1
1 1/4"	1
1 1/2"	1
2"	1,2
2 1/2"	1,2
3"	1,2,3
4"	1,2,3
4" Z	1,2,3,4
5"	1,2,3
5" Z	1,2,3,4
6"	1,2,3
6" Z	1,2,3,4
8"	1,2,3
8" Z	1,2,3,4

- Using sealing tape screw the flow monitor into a T piece according to DIN 2950 with 1" outlet. The arrow on the housing must point in the direction of flow.
- The unit can be fitted in any position. If the unit is installed in a vertical pipe the weight of the paddle and the lever must be compensated with the range screw. This leads to changes in switching value (see Section 8 Setting the Limit Contact)
- A suitable filter must be connected upstream for soiled media. This applies especially to fibrous soiling.

7. Electrical Connection

- Make sure that the voltage and current values in your plant do not exceed the respective voltage and current values specified for the flow monitor.
- Make sure that the electrical supply lines are de-energized.
- Remove the flow monitor housing by undoing the four screws.
- Connect the flow monitor as shown in the wiring diagram.
- Red-white opens if the flow rate drops to the set value. Red-blue close simultaneously and can be used as a signal contact

The unit is ready for operation when you have connected your external devices to the limit contact.

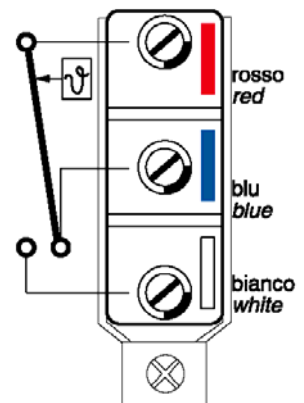

8. Setting the Limit Contact

The units are delivered with an adjustable microswitch.

The contact is a changeover contact that can be wired for use as a N/O or N/C contact.

The units are set to the minimum switch-off value at the factory.

The switch-off value can be set to a higher value by rotating the range screw clockwise.

9. Maintenance

In cases where the flow medium is uncontaminated, the FPS will remain maintenance-free. Large dirt particles can block the paddle / lever arm. Depending on the amount of dirt present in the medium, we recommend that the Instrument is checked at regular intervals.

10. Technical Information

Brass design:	Bellows MS 58 Bronze Paddle 316L St. Steel
T piece:	Zinc-plated Steel
Stainless steel design:	Bellows 321 St. Steel Paddle 316L St. Steel
Max. medium temperature:	-40°F to 250°F (-40° to +120°C)
Max. ambient temperature:	-30°F to 150°F (-35° to + 65°C)
Max. allowed pressure:	Brass 160 PSIG (11 Bar) Stainless Steel 435 PSIG (30 Bar)
Max. pressure loss:	Approx. 0.15-0.44 PSIG (0.01-0.03 Bar)
Inlet and outlet pipe section:	5x Nominal Pipe Diameter

Electrical details

Dust-proof microswitch, single-pole changeover contact (SPDT)

Switching voltage: max. 24-250 V_{AC}

Switching current: max. 8 A (inductive load)
max. 15 A (resistive load)

Case: ABS
Protection type: IP 65

11. Order Codes

Pipe Size	Standard Switching Ranges Series FPS-5...				Special Switching Ranges Series FPS-6...					
	GPM Water De-actuating	GPM Water Actuating	Max. Flow Rate (Water)	Order Number		GPM Water De-actuating	GPM Water Actuating	Max. Flow Rate (Water)	Order Number	
				Brass	St. Steel				Brass	St. Steel
1"	2.6...8.8	4.4...9.3	15.8	FPS-5100P	FPS-5200P	0.9...4.4	2.6...4.8	15.8	FPS-6100P	FPS-6200P
1-1/4"	3.5...12.3	5.7...13.2	26.4			1.1...6.2	4.0...7.0	26.4		
1-1/2"	4.8...16.3	7.5...17.6	39.6			2.2...7.0	5.3...9.7	39.6		
2"	9.7...25.1	13.7...26.9	66.0			4.0...15.9	10.1...18.1	66.0		
2-1/2"	11.9...28.6	17.6...30.8	105			5.3...21.6	13.7...24.2	105		
3"	18.9...47.1	27.3...50.2	158			9.3...32.6	21.6...36.1	158		
4"	50.2...122.0 (26.9 - 76.2)	64.7...127.7 (35.2 - 81.0)	264			21.6...75.3 (14.5...51.0)	49.8...84.1 (33.9...57.2)	264		
5"	100.8...234.7 (41.0 - 111.0)	125.1...244.8 (56.8...118.0)	413			42.7...149.7 (22.0...77.0)	98.6...166.9 (50.6...86.3)	413		
6"	158.1...360.0 (54.2...134.7)	189.8...375.0 (74.0...144.0)	528			59.9...209.6 (26.9...94.2)	138.7...234.2 (62.1...105.2)	528		
8"	319.7...729.6 (170.0...400.0)	374.7...759.5 (204.7...414.8)	1056			113.2...396.7 (95.6...243.5)	262.4...443.4 (160.7...272.1)	1056		

The values in brackets apply when using the supplied long paddle, shortened accordingly for service in larger, 4" ...6" pipes, in addition to the three shorter paddles.

12. Dimensions

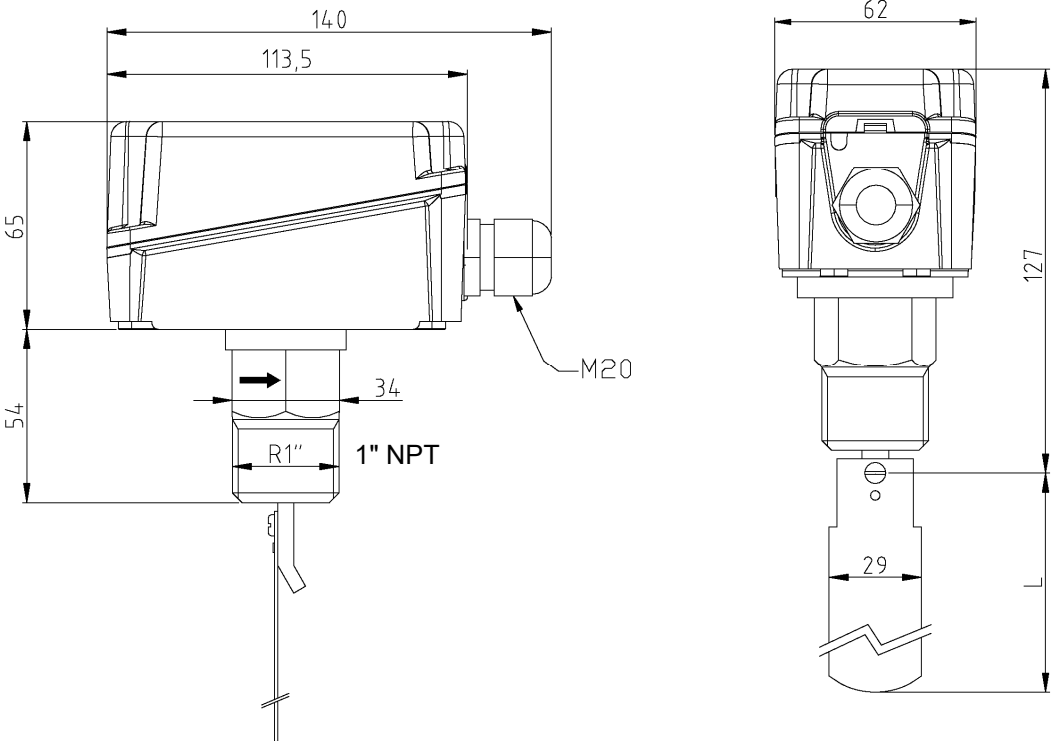

Mounting Instructions

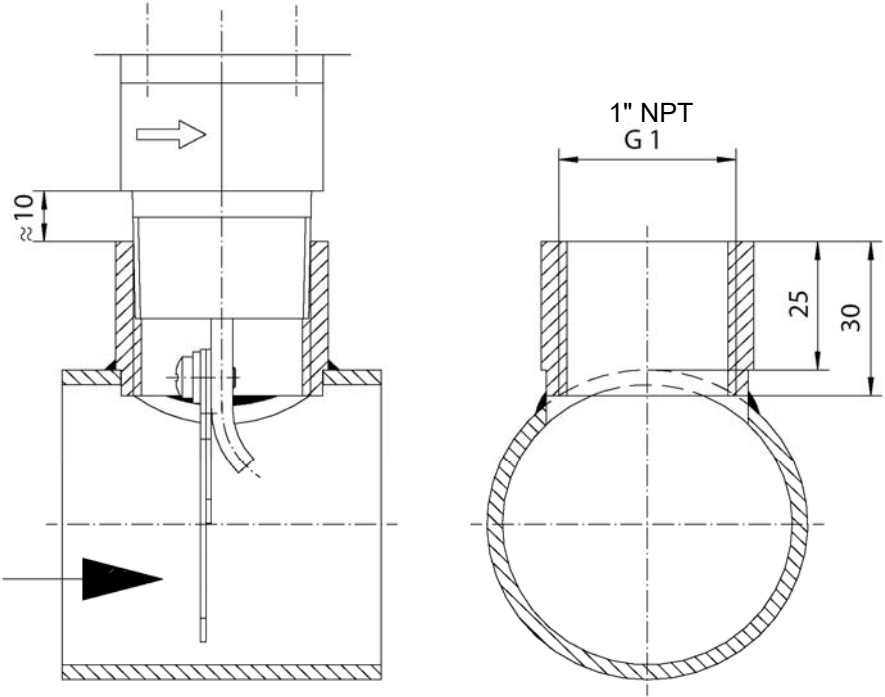

13. EU Declaration of Conformance

We, KOBOLD-Messring GmbH, Hofheim-Ts, Germany, declare under our sole responsibility that the product:

Paddle Bellows Flow Monitor Model: FPS-...

to which this declaration relates is in conformity with the standards noted below:

EN 60730-2:15:2010

Automatic electrical controls for household and similar use - Part 2-15: Particular requirements for automatic electrical air flow, water flow and water level sensing controls

Also the following EC guidelines are fulfilled:

2014/30/EU

EMC Directive

2014/35/EU

Low Voltage Directive

2011/65/EU

RoHS (category 9) industrial monitoring and control instruments, compliant, no CE-marking for the transitional period until 2017

Hofheim, 11. Oct. 2016



H. Peters
General Manager

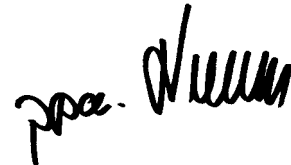

M. Wenzel
Proxy Holder