

**Operating Instructions  
for  
Sight Glass with Rotor,  
Drip Tube or Flap**

**Model: DAR-...**

**DAT-...**

**DAK-...**



Order from: **C A Briggs Company**  
622 Mary Street; Suite 101; Warminster, PA 18974  
Phone: 267-673-8117 - Fax: 267-673-8118  
[Sales@cabriggs.com](mailto:Sales@cabriggs.com) - [www.cabriggs.com](http://www.cabriggs.com)

## 1. Contents

---

1. Contents.....	2
2. Note .....	3
3. Regulation Use.....	4
3.1 Risk and Safety References .....	4
4. Operating Principle.....	5
4.1 Intended Use and Material Selection .....	5
5. Storage, Transport and Instrument Inspection .....	6
6. Installation and First Starting-Up .....	6
6.1 Installation.....	7
6.2 Initial Start-up.....	7
7. Technical Information.....	8
8. Order Codes .....	10
9. Maintenance .....	12
10. Replacement of Glass Plates .....	13
10.1 Disassembly .....	13
10.2 New Assembly .....	13
11. Dimensions .....	15
12. Manufacturer's Declaration .....	21
13. EU Declaration of Conformance.....	22

### Manufactured and sold by:

Kobold Messring GmbH  
Nordring 22-24  
D-65719 Hofheim  
Tel.: +49(0)6192-2990  
Fax: +49(0)6192-23398  
E-Mail: info.de@kobold.com  
Internet: www.kobold.com

## 2. Note

Please read these operating instructions before unpacking and putting the unit into operation. Follow the instructions precisely as described herein.

The devices are only to be used, maintained and serviced by persons familiar with these operating instructions and in accordance with local regulations applying to Health & Safety and prevention of accidents.

When used in machines, the measuring unit should be used only when the machines fulfil the EC-machine guidelines.

**as per PED 2014/68/EU**

	Pipe Diagram 8 Group 1 dangerous fluids	
DAR,DAT,DAK, ≤ DN 25	Art. 4, Par. 3	no CE mark
DAR,DAT,DAK, DN 32/PN 10 up to DN 100/PN 10	Cat. I, module A	CE marking
DAR,DAT,DAK, DN 32/PN 16 up to DN 50/PN 16	Cat. I, module A	CE marking
DAR,DAT,DAK, DN 32/PN 25 up to DN 40/PN 25	Cat. I, module A	CE marking
DAR,DAT,DAK, DN 125/PN 10 up to DN 350/PN 10	Cat. II, module A2	CE marking
DAR,DAT,DAK, DN 65/PN 16 up to DN 200/PN 16	Cat. II, module A2	CE marking
DAR,DAT,DAK, DN 50/PN 25 up to DN 125/PN 25	Cat. II, module A2	CE marking
DAR,DAT,DAK, DN 32/PN 40 up to DN 100/PN 40	Cat. II, module A2	CE marking

## 3. Regulation Use

---

Any use of the Sight Glass, model: DAR, DAT, DAK-... which exceeds the manufacturer's specifications may invalidate its warranty. Therefore any resulting damage is not the responsibility of the manufacturer. The user assumes all risk for such usage.

### 3.1 Risk and Safety References

Very careful handling of the KOBOLD Sight Glass is required:

- It must be guaranteed that all work on or with glass plates and KOBOLD Sight Glass is done by trained personnel.
- The valid safety regulations, especially for pipings under pressure and temperature, must be considered.
- Before first starting up please follow the instructions mentioned under section 6 !
- For cleaning and maintenance please follow the instructions mentioned under section 9 and 10 !
- Installation and maintenance must be done exclusively in atmospheric pressure and flow ambient temperature conditions. Shut off supply pipes and waste pipes, in case of back pressure.
- Please use only KOBOLD spare parts.



---

**Attention! Wear protective glasses anytime! During operation, the KOBOLD Sight Glass is often under pressure and mostly high temperatures! Maintenance during operation could present a danger of serious burning or cauterisation by contact with the process fluid.**

---

## 4. Operating Principle

The KOBOLD Sight Glass is installed into piping (flanged, screwed or welded). It serves to make the visual inspection of medium flow possible, concerning quality and quantity. For this, the Sight Glass with Rotor is provided with 2 opposite glass plates.

### 4.1 Intended Use and Material Selection

Operational area and material selection are the responsibility of the operator and/or designer of the system:

#### Body material and seals

These must be selected carefully with consideration of the flowing medium as well as the operating conditions (pressure and temperature).

#### Glass plates

- Soda lime glass according to DIN 8902: max. 150 °C
- Borosilicate glass according to DIN 7080: max. 260 °C
- Within the very low temperature range there are no limits for the glass plates. However AD-2000-Instruction W 10 for body and screw materials is to be considered!
- Additional protection by mica sheets is recommended for desalinated condensate or steam mixture and pH values starting from 8.

#### Pressure - Temperature – Operational Limits

Operating temperature	120 °C	150 °C	200 °C	250 °C	280 °C
PN 16 / ANSI 150 lbs	16 bar	15 bar	14 bar	13 bar	11 bar
PN 25	25 bar	23 bar	22 bar	20 bar	17 bar
PN 40 / ANSI 300 lbs	40 bar	37 bar	35 bar	32 bar	28 bar



**Attention! The lowest value in the combination “body – seals – glass plates” determines the maximally permissible limit for temperature and pressure!**

## 5. Storage, Transport and Instrument Inspection

---

The Sight Glasses with Rotor are to be transported and stored in professional packaging. They must be kept dry and protected against dirt. Especially the glass plates must be protected against impact and scratching.

<b>Storage:</b>	From –10 °C to +40 °C in a clean and dry room.
<b>Period of storage:</b>	Max. 3 years. After that time the seals must be checked and possibly replaced.
<b>Lacquer finish:</b>	Cast iron and cast steel Sight Glasses are provided with a basic colour which is to protect the Sight Glass against corrosion only during transport and storage. Therefore take care not to damage the colour. Condensation must be absolutely avoided.

**Protective caps** should be removed only shortly before installation to protect the sealing surface.

Instruments are inspected before shipping and sent out in perfect condition. Should damage to a device be visible, we recommend a thorough inspection of the delivery packaging. In case of damage, please inform your parcel service / forwarding agent immediately, because they are responsible for damages during transit.

**Scope of delivery:**

The standard delivery includes:

- Sight Glass model: DAR-.../DAT-.../DAK-...
- Operating Instructions

## 6. Installation and First Starting-Up

---

- Any installation position is possible (except design with flap: installation horizontal or vertical with flow upwards).
- The indication arrow for the flow direction is to be considered absolutely.
- Before installation take care that the piping and Sight Glass with Rotor are free of dirt.
- Transmission of piping tensions on the Sight Glass with Rotor, due to the installation process, is to be avoided
- Remove protection caps only shortly before installation to avoid damages of the contact faces.

## 6.1 Installation

### Flange connection

Piping flanges have to be concentrically aligned and parallel. Size of the flange and type of contact faces must fit the Sight Glass with Rotor (see DIN 2526). Distance of piping flanges = length of Sight Glass plus twice seal thickness. The connection screws must be tightened alternately in a crosswise pattern, gradually and steadily (see picture in section 10.2). The torque depends mainly on the sealing material used.

### Thread connection

The thread of the Sight Glass must fit the external thread of the piping in thread type, size and lead. When screwing in, the Sight Glass with Rotor must be secured directly at the threaded end with a suitable fork wrench or pliers. Absolutely do not grip in the area of the sight glass covers, because glass breakage is possible.



---

**Attention! Glass plates and seals should be removed during the welding procedure or should be covered inside and outside to protect them against welding gases and welding splashes.**  
**- See section 10: Replacement of glass plates**

---

## 6.2 Initial Start-up

- Before initial start-up the torques of the fixing screws of the two cover flanges should be checked and corrected (especially after a longer intermediate storage!). The torques and procedure described in section 10 (Replacement of glass plates) are to be considered!
- After the initial loading with pressure and temperature, a certain “settling” of the seals will occur. Therefore the fixing screws of the covers are to be checked once more under cold, pressureless conditions (as described in section 10) and possibly corrected.

## 6.3 Use in potentially explosive atmospheres

We would like to point out that the devices must be included in the equipotential bonding when installing in hazardous areas like all mechanical components.

## 7. Technical Information

	DAR-11	DAR-13	DAR-12
Rotor:	plastic (up to 120 °C); option »R« PTFE up to 260 °C (nominal size 2": PTFE standard)		
Housing:	grey cast iron 0.6025	cast steel 1.0619	stainless steel 1.4408
Cover plates:	grey cast iron 0.6025	C 22.8	stainless steel 1.4301
Sight glass:	soda lime glass DIN 8902 (up to 150 °C);option: borosilicate glass DIN 7080 (up to 260 °C)		
Screws:	zinc plated steel		stainless steel
Sealing:	graphite (PTFE or other on request)		
Mounting position:	universal		
Operating pressure:	16 bar (Option 25 or 40 bar for DAR-12... and DAR-13...)		

	DAR-21	DAR-23	DAR-22
Rotor:	up to DN 40: plastic (up to 120 °C); option »R« PTFE up to 260 °C / from DN 50: PTFE		
Housing:	grey cast iron 0.6025	cast steel 1.0619	stainless steel 1.4408
Cover plates:	grey cast iron 0.6025 / R St 37-2	C 22.8 / R St 37-2	stainless steel 1.4301
Sight glass:	soda lime glass DIN 8902 (up to 150 °C);option: borosilicate glass DIN 7080 (up to 260 °C)		
Screws:	zinc plated steel		stainless steel
Sealing:	graphite (PTFE or other on request)		
Mounting position:	universal		
Operating pressure:	16 bar (option 25 or 40 bar for DAR-22... and DAR-23...)		

	DAK-11	DAK-13	DAK-12
Flap:	stainless steel 1.4571		
Housing:	grey cast iron 0.6025	cast steel 1.0619	stainless steel 1.4408
Cover plates:	grey cast iron 0.6025	C 22.8	Stainless steel 1.4301
Sight glass:	soda lime glass DIN 8902 (up to 150°C); option: borosilicate glass DIN 7080 (up to 280°C)		
Screw:	zinc plated steel		stainless steel
Sealing:	graphite (PTFE or other on request)		
Mounting position:	horizontal or vertical with flow from below		

	DAK-21	DAK-23	DAK-22
Flap:	stainless steel 1.4571		
Housing:	grey cast iron 0.6025	cast steel 1.0619	stainless steel 1.4408
Cover plates:	grey cast iron 0.6025/R St 37-2	C 22.8/R St 37-2	stainless steel 1.4301
Sight glass:	soda lime glass DIN 8902 (up to 150°C); option: borosilicate glass DIN 7080 (up to 280°C)		
Screws:	zinc plated steel		stainless steel
Seals:	graphite (PTFE or other on request)		
Mounting position:	horizontal or vertical with flow from bottom to top		



# DAR/DAT/DAK

---

	<b>DAT-11</b>	<b>DAT-13</b>	<b>DAT-12</b>
Housing:	grey cast iron 0.6025	cast steel 1.0619	stainless steel 1.4408
Cover plates:	grey cast iron 0.6025	C 22.8	stainless steel 1.4301
Sight glass:	soda lime glass DIN 8902 (up to 150°C); option: borosilicate glass DIN 7080 (up to 280°C)		
Screws:	zinc plated steel		stainless steel
Seals:	graphite (PTFE or on request)		
Mounting position:	any position, preferably vertical, flow from top		

	<b>DAT-21</b>	<b>DAT-23</b>	<b>DAT-22</b>
Housing:	grey cast iron 0.6025	cast steel 1.0619	stainless steel 1.4408
Cover plates:	grey cast iron 0.6025/R St 37-2	C 22.8/R St 37-2	stainless steel 1.4301
Sight glass:	soda lime glass DIN 8902 (up to 150°C); option: borosilicate glass DIN 7080 (up to 280°C)		
Screws:	zinc plated steel		stainless steel
Seals:	graphite (PTFE or on request)		
Mounting position:	any position, preferably vertical, flow from top		

## 8. Order Codes

Example: DAR-1101H R08

DN	DAR-11	DAR-13	DAR-12	Connection		Option
	soda lime glass, graphite-sealing, plastic rotor			G-thread	NPT-thread*	
	Grey cast iron	Cast steel	Stainless steel			add option letter to order number
1/4"	DAR-1101H..	DAR-1301H..	DAR-1201H..	R08	N08	<b>Option »B«</b> borosilicate glass, graphite-sealing <b>Option »R«</b> PTFE-Rotor  <b>Option »P«</b> 25 bar for DAR-12... and DAR-13... <b>Option »Q«</b> 40 bar for DAR-12... and DAR-13...
3/8"	DAR-1102H..	DAR-1302H..	DAR-1202H..	R10	N10	
1/2"	DAR-1103H..	DAR-1303H..	DAR-1203H..	R15	N15	
3/4"	DAR-1104H..	DAR-1304H..	DAR-1204H..	R20	N20	
1"	DAR-1105H..	DAR-1305H..	DAR-1205H..	R25	N25	
1 1/4"	DAR-1106H..	DAR-1306H..	DAR-1206H..	R32	N32	
1 1/2"	DAR-1107H..	DAR-1307H..	DAR-1207H..	R40	N40	
2"	DAR-1108H..	DAR-1308H..	DAR-1208H..	R50	N50	

\*not for DAR-11 grey cast iron instruments

Example: DAR-2201H F15

Flanged conn. DN	DAR-21	DAR-23	DAR-22	Connection		Option
	soda lime glass, graphite-sealing, plastic rotor			DIN-Flange	ANSI-Flange (only on request)	
	Grey cast iron	Cast steel	Stainless steel			add option letter to order number
15	DAR-2101H..	DAR-2301H..	DAR-2201H..	F15	A15	<b>Option »B«</b> borosilicate glass, graphite-sealing <b>Option »R«</b> PTFE-Rotor  <b>Option »P«</b> 25 bar for DAR-22... and DAR-23... <b>Option »Q«</b> 40 bar for DAR-22... and DAR-23...
20	DAR-2102H..	DAR-2302H..	DAR-2202H..	F20	A20	
25	DAR-2103H..	DAR-2303H..	DAR-2203H..	F25	A25	
32	DAR-2104H..	DAR-2304H..	DAR-2204H..	F32	A32	
40	DAR-2105H..	DAR-2305H..	DAR-2205H..	F40	A40	
50	DAR-2106H..	DAR-2306H..	DAR-2206H..	F50	A50	
65	DAR-2107H..	DAR-2307H..	DAR-2207H..	F65	A65	
80	DAR-2108H..	DAR-2308H..	DAR-2208H..	F80	A80	
100	DAR-2109H..	DAR-2309H..	DAR-2209H..	F1H	A1H	
125	DAR-2110H..	DAR-2310H..	DAR-2210H..	F1Z	A1Z	
150**	DAR-2111H..	DAR-2311H..	DAR-2211H..	F1F	A1F	
200**	DAR-2112H..	DAR-2312H..	DAR-2212H..	F2H	A2H	

\*\* with instrument glass only PN 10, PN 16 with Option «B» possible

Example: DAK-1101H R08

DN	DAK-11	DAK-13	DAK-12	Connection		Option
	soda lime glass, graphite-sealing			G-thread	NPT-thread*	
	Grey cast iron	Cast steel	Stainless steel			add option letter to order number
1/4"	DAK-1101H..	DAK-1301H..	DAK-1201H..	R08	N08	<b>Option »B«</b> borosilicate glass, graphite-sealing  <b>Option »P«</b> 25 bar for DAK-12... and DAK-13... <b>Option »Q«</b> 40 bar for DAK-12... and DAK-13...
3/8"	DAK-1102H..	DAK-1302H..	DAK-1202H..	R10	N10	
1/2"	DAK-1103H..	DAK-1303H..	DAK-1203H..	R15	N15	
3/4"	DAK-1104H..	DAK-1304H..	DAK-1204H..	R20	N20	
1"	DAK-1105H..	DAK-1305H..	DAK-1205H..	R25	N25	
1 1/4"	DAK-1106H..	DAK-1306H..	DAK-1206H..	R32	N32	
1 1/2"	DAK-1107H..	DAK-1307H..	DAK-1207H..	R40	N40	
2"	DAK-1108H..	DAK-1308H..	DAK-1208H..	R50	N50	

\*not for DAR-11 grey cast iron-instruments

## Example: DAK-2101H F15

Flanged con. DN	DAK-21	DAK-23	DAK-22	Connection		Option
	soda lime glass, graphite-sealing			DIN-Flange	ANSI-Flange (only on request)	
	Grey cast iron	Cast steel	St. steel			add option letter to order number
15	DAK-2101H..	DAK-2301H..	DAK-2201H..	F15	A15	<b>Option »B«</b> borosilicate glass, graphite-sealing  <b>Option »P«</b> 25 bar for DAK-22... and DAK-23...  <b>Option »Q«</b> 40 bar for DAK-22... and DAK-23...
20	DAK-2102H..	DAK-2302H..	DAK-2202H..	F20	A20	
25	DAK-2103H..	DAK-2303H..	DAK-2203H..	F25	A25	
32	DAK-2104H..	DAK-2304H..	DAK-2204H..	F32	A32	
40	DAK-2105H..	DAK-2305H..	DAK-2205H..	F40	A40	
50	DAK-2106H..	DAK-2306H..	DAK-2206H..	F50	A50	
65	DAK-2107H..	DAK-2307H..	DAK-2207H..	F65	A65	
80	DAK-2108H..	DAK-2308H..	DAK-2208H..	F80	A80	
100	DAK-2109H..	DAK-2309H..	DAK-2209H..	F1H	A1H	
125	DAK-2110H..	DAK-2310H..	DAK-2210H..	F1Z	A1Z	
150**	DAK-2111H..	DAK-2311H..	DAK-2211H..	F1F	A1F	
200**	DAK-2112H..	DAK-2312H..	DAK-2212H..	F2H	A2H	

\*\* with soda lime glass only PN 10, PN 16 with Option «B» possible

## Example: DAT-1101H R08

DN	DAT-11	DAT-13	DAT-12	Connection		Option
	soda lime glass, graphite-sealing			G-thread	NPT-thread*	
	Grey cast iron	Cast steel	St. steel			add option letter to order number
1/4"	DAT-1101H..	DAT-1301H..	DAT-1201H..	R08	N08	<b>Option »B«</b> borosilicate glass, graphite-sealing  <b>Option »P«</b> 25 bar for DAT-12... and DAT-13...  <b>Option »Q«</b> 40 bar for DAT-12... and DAT-13...
3/8"	DAT-1102H..	DAT-1302H..	DAT-1202H..	R10	N10	
1/2"	DAT-1103H..	DAT-1303H..	DAT-1203H..	R15	N15	
3/4"	DAT-1104H..	DAT-1304H..	DAT-1204H..	R20	N20	
1"	DAT-1105H..	DAT-1305H..	DAT-1205H..	R25	N25	
1 1/4"	DAT-1106H..	DAT-1306H..	DAT-1206H..	R32	N32	
1 1/2"	DAT-1107H..	DAT-1307H..	DAT-1207H..	R40	N40	
2"	DAT-1108H..	DAT-1308H..	DAT-1208H..	R50	N50	

\*not for DAT-11 grey cast iron-instruments

## Example: DAT-2101H F15

Flanged con. DN	DAT-21	DAT-23	DAT-22	Connection		Option
	soda lime glass, graphite-sealing			DIN-flange	ANSI-Flange (only on request)	
	Grey cast iron	Cast steel	St. steel			add option letter to order number
15	DAT-2101H..	DAT-2301H..	DAT-2201H..	F15	A15	<b>Option »B«</b> borosilicate glass, graphite-sealing  <b>Option »P«</b> 25 bar for DAT-22... and DAT-23...  <b>Option »Q«</b> 40 bar for DAT-22... and DAT-23...
20	DAT-2102H..	DAT-2302H..	DAT-2202H..	F20	A20	
25	DAT-2103H..	DAT-2303H..	DAT-2203H..	F25	A25	
32	DAT-2104H..	DAT-2304H..	DAT-2204H..	F32	A32	
40	DAT-2105H..	DAT-2305H..	DAT-2205H..	F40	A40	
50	DAT-2106H..	DAT-2306H..	DAT-2206H..	F50	A50	
65	DAT-2107H..	DAT-2307H..	DAT-2207H..	F65	A65	
80	DAT-2108H..	DAT-2308H..	DAT-2208H..	F80	A80	
100	DAT-2109H..	DAT-2309H..	DAT-2209H..	F1H	A1H	
125	DAT-2110H..	DAT-2310H..	DAT-2210H..	F1Z	A1Z	
150**	DAT-2111H..	DAT-2311H..	DAT-2211H..	F1F	A1F	
200**	DAT-2112H..	DAT-2312H..	DAT-2212H..	F2H	A2H	

\*\* with soda lime glass only PN 10, PN 16 with Option «B» possible

## 9. Maintenance

---

KOBOLD Sight Glasses do not require a special maintenance.

- If the glass plates should be dirty at the outside, they can be cleaned carefully. The glass surface may not be scratched under any circumstances (stability loss!). Commercial cleaning agents, especially glass cleaning agents, may be used. Use only clean and soft cloth!
- Inside dirtying of the glass plates may also be cleaned as described before. If the dirt sticks so tight on the glass plates that cleaning as described above is no more successful, the glass plates have to be replaced. Replacement is also necessary if they are corroded by flow or aggressive medium and show an erosive surface (stability loss!). When assembling the cleaned or replaced glass plates, new seals in suitable quality are to be used under all circumstances. See section 10 (Replacement of glass plates) and item 3.1 (Safety references).
- General references: Although highly resistant, sight glass plates according to DIN 8902 and DIN 7080 are wearing parts with limited lifespan. This depends very much on the specific demand on operation. With rising temperature and rising pH value of the medium the glass erosion increases exponentially. High glass erosion can have a very negative effect on the operational safety. Therefore both glass plates and seals are to be replaced if there is recognisable glass erosion. It is advisable to document the specific period of use of the glass plates, so that empirical values of the lifespan can be collected. That way the punctual and routine replacement of the glass plates can be planned.

## 10. Replacement of Glass Plates

---



**Attention! All work on glass plates has to be done by trained personnel in compliance with the safety instructions mentioned in item 3.1! Glass plates require very careful treatment!**

---

### 10.1 Disassembly

- Remove the fixing screws of the cover flanges in several steps and crosswise.
- Remove the cover flanges. Remove the glass plates as well as the inside and outside seals.
- Clean the sealing surface on the body as well as the bearing surface in the cover flange carefully of sealing remainders and check them for damage (scores, wash out, impact spots etc.). Both surfaces must be absolutely clean, flat and without damage!

### 10.2 New Assembly

- Lay down the new inside seal (on the body side) and the new glass plate of correct size and quality exactly centrically. The seal may not project in the view diameter  $d_1$ . The glass plate has to show a constant gap of approx. 1 to 1.5mm at the complete outside diameter. A contact between a glass plate and the metal body must be avoided under any circumstances! This would lead to damage and total breakdown of the glass plate due to different extension coefficients.
- Lay down the outside seal (on the cover side) and the cover flange exactly centrically on the glass plate. Between glass plate and cover flange the gap of approx. 1 to 1.5 mm mentioned above must also be absolutely guaranteed.
- Screw in the fixing screws carefully and tighten them gently by hand. While doing so, all seals and the cover flange may not shift! Threads and bearing surfaces of the fixing screws have to be lubricated with temperature resistant thread paste (e.g. OKS ANTI-Seize-Paste) before screwing in to avoid seizing of materials and to guarantee defined friction values.

- Now tighten all screws in several little steps and crosswise (acc. to the opposite picture) with a torque wrench to the torques mentioned in the below chart. All screws must show exactly the same torque to avoid glass tensions.

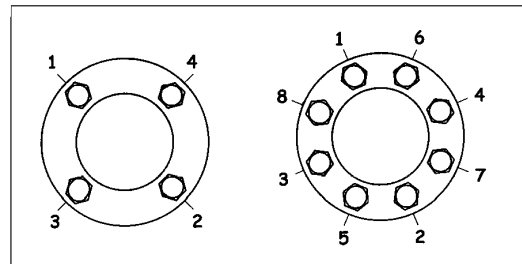

**Torques of cover flange screws [in Nm ]** for lubricated screws and for standard seals made of graphite with stainless steel reinforcement:

Glass Ø d2 in mm	View Ø d1 in mm	4xM8	4x M10	4x M12	4xM14	4x M14	8x M16
45	32	10	12	--	--	--	--
63	48	12	20	23	--	--	--
80	65	--	23	30	--	40	--
100	80	--	--	42	--	70	35
125	100	--	--	--	65	--	50
150	125	--	--	--	--	100	60
175	150	--	--	--	--	--	80
200	175	--	--	--	--	--	90

### Correction values for other sealing materials:

PTFE: above mentioned values x 0.5  
 Aramide fibre: above mentioned values x 0.7  
 FPM, Silicone, EPDM etc.: above mentioned values x 0.6  
 Other materials: on request

- Second opposite glass plate side is to be disassembled and assembled again as described above.
- Finally the sight glass fitting is to be checked for leak tightness (e.g. with compressed air/gas of approx. 2 bar under water).
- After first restarting the cover flange screws must be controlled absolutely as described in item 6.2 in cold and pressureless conditions to compensate for the “settling” of new seals.

## 11. Dimensions

### DAR-1.....

Dimensions for pressure rating PN 16

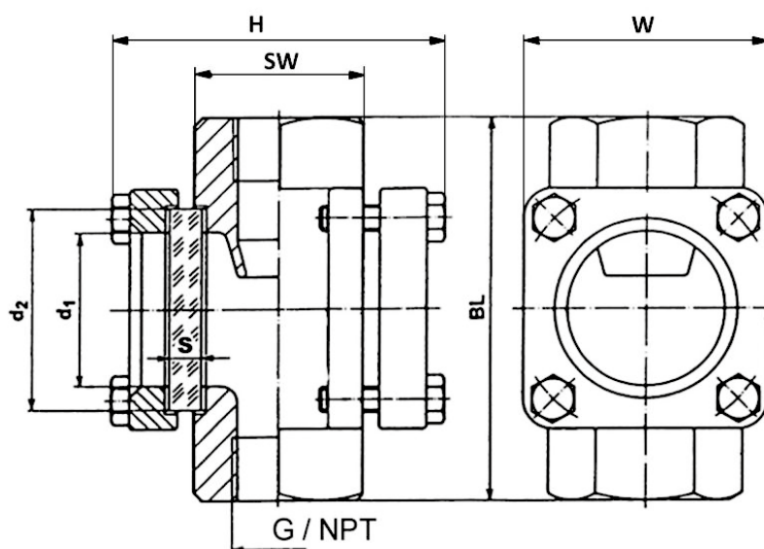

Dimensions (material grey cast iron) for pressure rating PN 16

G	BL [mm]	H [mm]	SW [mm]	W [mm]	d1 [mm]	d2 [mm]	Glass thickness (S) at PN 16 [mm]	Approx. weight DAR-11 ...
G 1/4 G 3/8 G 1/2	100	110	36	70	32	45	10	2,2 kg
G 3/4 G 1	120	120	46	85	45	63	10	3,5 kg
G 1 1/4 G 1 1/2	150	155	75	110	65	80	12	7,0 kg
G2	180	170	80	120	80	100	15	8,6 kg

Dimensions (material grey cast iron or stainless steel) for pressure rating PN 16 (PN25/PN40 on request)

G	BL [mm]	H [mm]	SW [mm]	W [mm]	d1 [mm]	d2 [mm]	Glass thickness (S) at PN 16 [mm]	Approx. weight DAR-12... DAR-13...
G 1/4 G 3/8 G 1/2 G 3/4	100	110	36	70	45	63	10	2,3 kg
G 1 G 1 1/4	130	120	46	85	65	80	12	4,1 kg
G 1 1/2	150	155	75	110	65	80	12	4,7 kg
G 2	230	180	ø90	120	80	100	15	7,7 kg

# DAR/DAT/DAK

## DAR-2....

Dimensions for pressure rating PN 16

DN	H [mm]	W [mm]	D [mm]	BL [mm]	d1 [mm]	d2 [mm]	Glass thickness (S) at PN 16 [mm]	Approx. weight [kg]	
								DAR 21...	DAR-22... DAR-23...
15	95	70	95	130	32	45	10	3,6	3,6
20	95	70	105	150	32	45	10	4,0	4,0
25	115	85	115	160	48	63	10	6,0	6,3
32	115	85	140	180	48	63	12	7,0	7,4
40	135	110	150	200	65	80	12	10,0	10,6
50	160	120	165	230	80	100	15	13,2	14,4
65	185	∅ 175	185	290	80	100	15	22,1	24
80	210	∅ 190	200	310	100	125	20	29,9	31,6
100	250	∅ 210	220	350	125	150	25	38,4	41,7
125	265	∅ 235	250	400	150	175	25	47,0	47,6
150	290	∅ 260	285	480	175	200	25*	59,0	67,6
200	360	∅ 285	340	600	175	200	25*	98,0	118,0

\* with soda lime glass only PN 10, PN 16 with option »B« possible

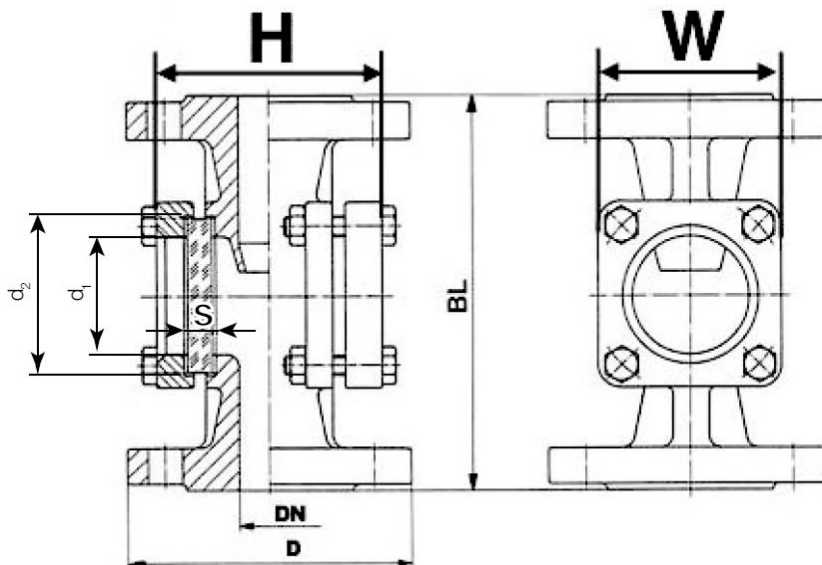



## DAK-1...

Dimensions for pressure rating PN 16

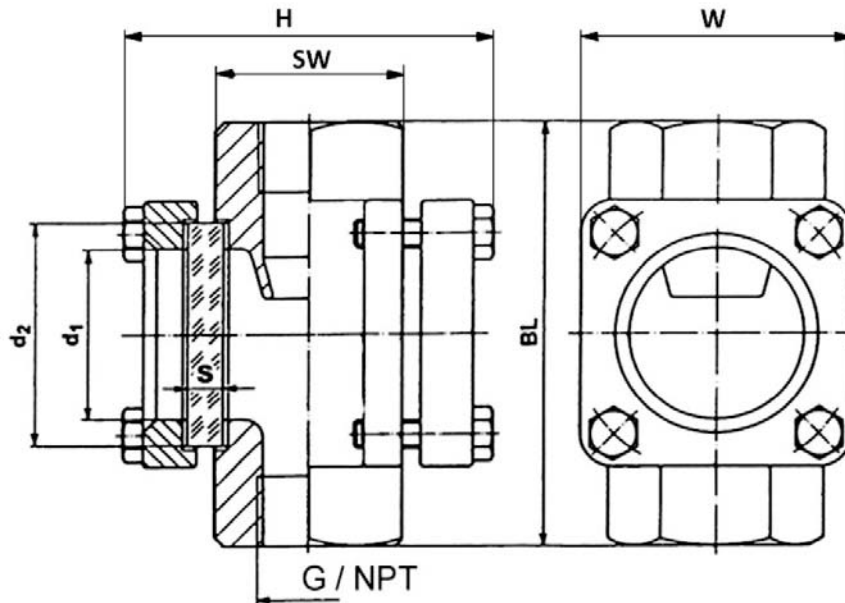

Dimensions (material grey cast iron) for pressure rating PN 16

G	BL [mm]	H [mm]	SW [mm]	W [mm]	d1 [mm]	d2 [mm]	Glass thickness (S) at PN 16 [mm]	Approx. weight DAK-11...
G 1/4 G 3/8 G 1/2	100	110	36	70	32	45	10	2,2 kg
G 3/4 G 1	120	120	46	85	45	63	10	3,4 kg
G 1 1/4 G 1 1/2	150	155	75	110	65	80	12	7,0 kg
G 2	180	170	80	120	80	100	15	8,6 kg

Dimensions (material cast steel or stainless steel)  
for pressure rating PN 16 (PN 25/PN 40 on request)

G	BL [mm]	H [mm]	SW [mm]	W [mm]	d1 [mm]	d2 [mm]	Glass thickness (S) at PN 16 [mm]	Approx. weight DAK-12... DAK-13...
G 1/4 G 3/8 G 1/2 G 3/4	100	110	36	70	32	45	10	2,2 kg
G 1 G 1 1/4	130	120	46	85	45	63	10	3,4 kg
G 1 1/2	150	155	75	110	65	80	12	7,0 kg
G 2	230	180	∅ 90	120	80	100	15	10,2 kg

# DAR/DAT/DAK

## DAK-2...

Dimensions for pressure rating PN 16

DN	H [mm]	W [mm]	D [mm]	BL [mm]	d1 [mm]	d2 [mm]	Glass thickness (S) at PN 16* [mm]	Approx. weight [kg]	
								DAK 21...	DAK-22... DAK-23...
15	95	70	95	130	32	45	10	3,6	3,6
20	95	70	105	150	32	45	10	4,0	4,0
25	115	85	115	160	48	63	10	6,0	6,3
32	115	85	140	180	48	63	10	7,0	7,4
40	135	110	150	200	65	80	12	10,0	10,6
50	160	120	165	230	80	100	15	13,2	14,4
65	185	∅ 175	185	290	80	100	15	22,1	24
80	210	∅ 190	200	310	100	125	20	29,9	31,6
100	250	∅ 210	220	350	125	150	25	38,4	41,7
125	265	∅ 235	250	400	150	175	25	47,0	47,8
150	290	∅ 260	285	480	175	200	25*	59,0	67,6
200	360	∅ 285	340	600	175	200	25*	98,0	118,0

\* with soda lime glass only PN 10, PN 16 with option »B« possible

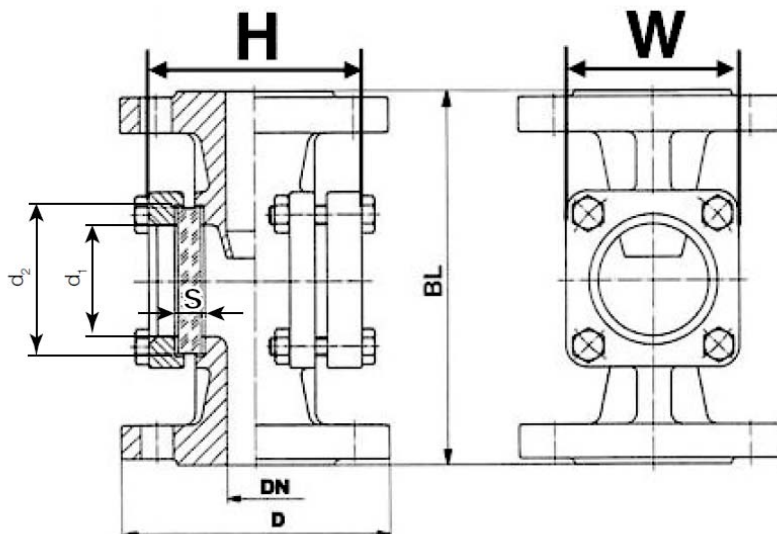

## DAT-1...

Dimensions for pressure rating PN 16

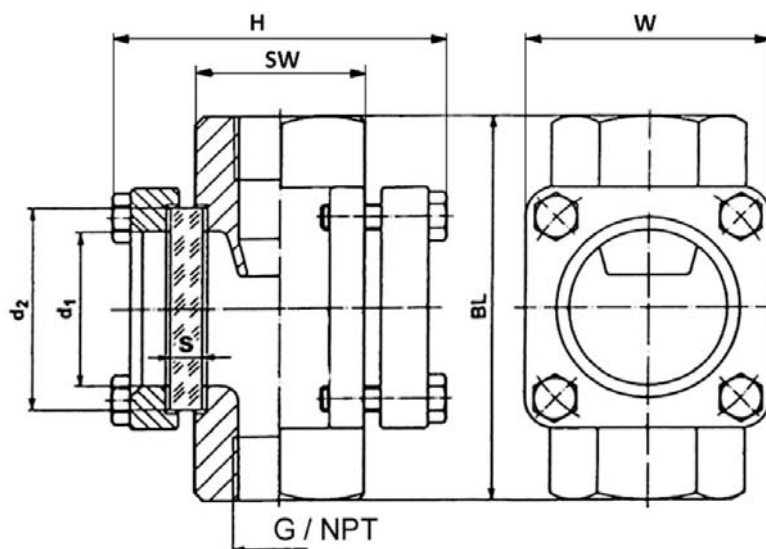

Dimensions (material grey cast iron) for pressure rating PN 16

G	BL [mm]	H [mm]	SW [mm]	W [mm]	d1 [mm]	d2 [mm]	Glass thickness (S) at PN 16 [mm]	Approx. weight DAT-11...
G 1/4 G 3/8 G 1/2	100	110	36	70	32	45	10	2,2 kg
G 3/4 G 1	120	120	46	85	45	63	10	3,4 kg
G 1 1/4 G 1 1/2	150	155	75	110	65	80	12	7,0 kg
G 2	180	170	80	120	80	100	15	8,6 kg

Dimensions (material cast steel or stainless steel)  
for pressure rating PN 16 (PN 25 / PN 40 on request)

G	BL [mm]	H [mm]	SW [mm]	W [mm]	d1 [mm]	d2 [mm]	Glass thickness (S) at PN 16 [mm]	Approx. weight DAT-12... DAT-13...
G 1/4 G 3/8 G 1/2 G 3/4	100	110	36	70	32	45	10	2,2 kg
G 1 G 1 1/4	130	120	46	85	45	63	10	3,4 kg
G 1 1/2	150	155	75	110	65	80	12	7,0 kg
G 2	230	180	ø 90	120	80	100	15	10,2 kg

# DAR/DAT/DAK

## DAT-2...

Dimensions for pressure rating PN 16

DN	H [mm]	W [mm]	D [mm]	BL [mm]	d1 [mm]	d2 [mm]	Glass thickness (S) at PN 16* [mm]	Approx. weight [kg]	
								DAT 21...	DAT-22... DAT-23...
15	95	70	95	130	32	45	10	3,6	3,6
20	95	70	105	150	32	45	10	4,0	4,0
25	115	85	115	160	48	63	10	6,0	6,3
32	115	85	140	180	48	63	10	7,0	7,4
40	135	110	150	200	65	80	12	10,0	10,6
50	160	120	165	230	80	100	15	13,2	14,4
65	185	∅ 175	185	290	80	100	15	22,1	24,0
80	210	∅ 190	200	310	100	125	20	29,9	31,6
100	250	∅ 210	220	350	125	150	25	38,4	41,7
125	265	∅ 235	250	400	150	175	25	47,0	47,0
150	290	∅ 260	285	480	175	200	25**	59,0	67,0
200	360	∅ 285	340	600	175	200	25**	98,0	118,0

\* Pressure rating PN 25 / PN 40 on request!

\*\* with soda lime glass only PN 10, PN 16 with option »B« possible

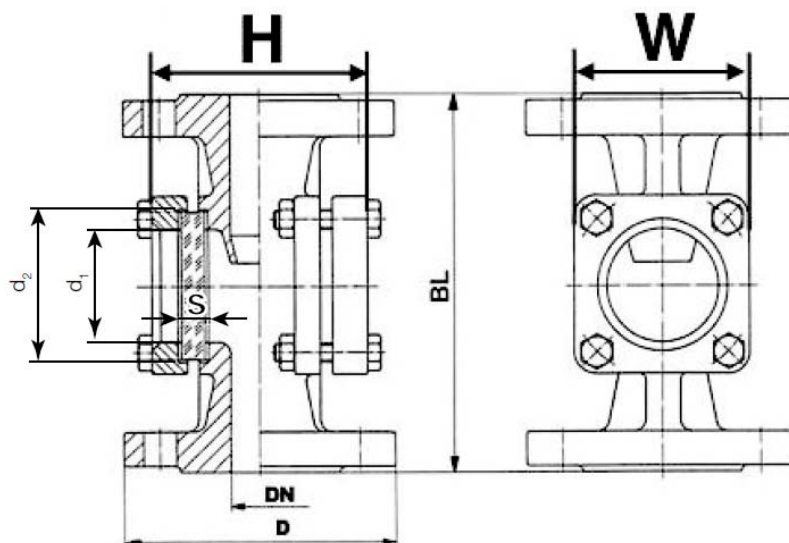

## **12. Manufacturer's Declaration**

---

**Manufacturer:** Kobold-Messring GmbH  
Hofheim/Ts.  
Bundesrepublik-Deutschland

**Sight Glass**    **Model: DAR, DAT, DAK**

The Sight Glasses DAR, DAT, DAK (without integrated electronic equipment) do not have a potential igniting source of its own, therefore these devices do not get any identification according to the ATEX-guideline 2014/34/EU.

The sight glasses may be used in hazardous areas.

We would like to point out that the devices must be included in the equipotential bonding when installing in hazardous areas like all mechanical components.

Hofheim, 15. Aug. 2018



H. Peters  
General Manager

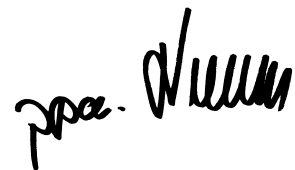

M. Wenzel  
Proxy Holder

## 13. EU Declaration of Conformance

---

We, KOBOLD Messring GmbH, Hofheim-Ts, Germany, declare under our sole responsibility that the product:

**Sight Glass**                      **model: DAR/DAT/DAK-...** (only devices > DN 25)

to which this declaration relates is in conformity with the standards noted below:

EN 558: Industrial valves - Lengths of metal fittings for installation in pipelines with flanges - Fittings marked PN and Class

EN 1092: Flanges and their joints - Round flanges for pipes, fittings, fittings and accessories, designated PN

EN 12266: Industrial valves - Testing of metal fittings

EN 12516: Industrial valves - Housing strength

Also the following EC guidelines are fulfilled:

### 2014/68/EU PED

- Group 1 dangerous fluids
- Module D, marking CE0575
- Notified body: DNV GL
- Certificate No. PEDD000000R

DAR,DAT,DAK, ≤ DN 25	Art. 4, Par. 3	no CE mark
DAR,DAT,DAK, DN 32/PN 10 up to DN 100/PN 10	Cat. I, module A	CE marking
DAR,DAT,DAK, DN 32/PN 16 up to DN 50/PN 16	Cat. I, module A	CE marking
DAR,DAT,DAK, DN 32/PN 25 up to DN 40/PN 25	Cat. I, module A	CE marking
DAR,DAT,DAK, DN 125/PN 10 up to DN 350/PN 10	Cat. II, module A2	CE marking
DAR,DAT,DAK, DN 65/PN 16 up to DN 200/PN 16	Cat. II, module A2	CE marking
DAR,DAT,DAK, DN 50/PN 25 up to DN 125/PN 25	Cat. II, module A2	CE marking
DAR,DAT,DAK, DN 32/PN 40 up to DN 100/PN 40	Cat. II, module A2	CE marking



Hofheim, 21. Aug. 2018

H. Peters  
General Manager



M. Wenzel  
Proxy Holder