

Operating Instruction
for
Flowmeter and Monitor

Model: BVO, RVO

Order from: **C A Briggs Company**

622 Mary Street; Suite 101; Warminster, PA 18974

Phone: 267-673-8117 - Fax: 267-673-8118

Sales@cabriggs.com - www.cabriggs.com

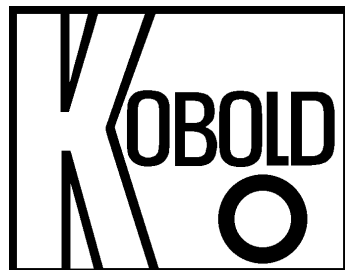

1. Contents

1. Contents.....	2
2. Note	3
3. Regulated usage.....	3
4. Operating Principle.....	4
5. Instrument Inspection.....	4
6. Mechanical connection.....	5
7. Electrical connection	6
8. Commissioning of the Instruments.....	7
9. Maintenance	8
10. Technical Specifications.....	8
11. Dimensions and Pressure Losses.....	9
12. Recommended Spare Parts.....	9
13. EU Declaration of Conformance.....	10

Manufactured and sold by:

Kobold Messring GmbH
Nordring 22-24
D-65719 Hofheim
Tel.: +49(0)6192-2990
Fax: +49(0)6192-23398
E-Mail: info.de@kobold.com
Internet: www.kobold.com

2. Note

Please read and take note of these operating instructions before unpacking and setting the unit for operation, and follow the instructions precisely as described herein.

The devices are only to be used, maintained and serviced by persons familiar with these operating instructions and with the prevailing regulation applying to procedural safety and the prevention of accidents.

PED 2014/68/EU

In acc. with Article 4 Paragraph (3), "Sound Engineering Practice", of the PED 2014/68/EU no CE mark.

Table 8, Pipe, Group 1 dangerous fluids

3. Regulated usage

Model BVO and RVO instruments are used for monitoring of fluid flows. Only clean, low viscosity and homogenous media may be measured, which do not affect the materials used in the instrument casing. Large measuring errors will occur when using high viscosity media. Large dirt particles can lead to blocking of the float and therefore large measurement and signal errors. Ferritic particles that deposit on the float body (with internal magnet) can also lead to a similar effect therefore we recommend a magnet filter.

The instruments are provided as follows:

Flow measurement

The actual flow can be read locally at the instrument.

The scale shows the flow rate directly in litres per minute of water.

Limit Value Contacts

For the monitoring of the flow rate, the instruments can be fitted with one or two adjustable limit value contacts.

Standard Design:	Normally open (with rising flow)
Special Design:	Changeover switch (SPDT)
Special Design:	Ex-contact N/O, Ex-contact SPDT

The contact is adjustable over the full measuring range.

Standard Material Combinations

	Model : BVO-11..	Model : BVO-12..	Model : RVO-11..
	Material: Brass	Material: St.St.	Material: Brass
Slotted nozzle	Brass, nickel plated	1.3955	Brass, nickel plated
Connection	Brass, nickel plated	1.4301	Brass, nickel plated
Float	Brass, nickel plated	1.4301	Brass, nickel plated
Measuring Tube	Borosilicat	Borosilicat	Borosilicat
O-Rings	Perbunan	Viton	Perbunan
Tmax	100° C	100° C	100° C
Pmax	10 bar	10 bar	10 bar

4. Operating Principle

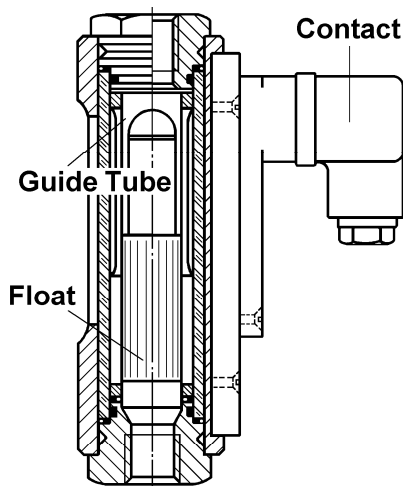

The model BVO and RVO flow monitors are based on the principle of the well-known float type flowmeters except for the conventional upward tapering measuring tube. These patented instruments are provided instead with a cylindrical guidetube with conical slots along the periphery. A float is found in this tube which, by means of the flow of the medium, is raised in the tube. Each float position corresponds to a certain flow.

Permanent magnets are inserted in the float which activates reed switches mounted outside of the flow throughput. The activation of the contacts is carried out by means of magnetic field, ie: the contact is hermetically separated from the flowing medium.

5. Instrument Inspection

The instruments are inspected before dispatch and sent out in perfect condition. Should damage to the instrument be visible, we recommend close inspection of the delivery package. In cases of damage, please immediately inform the shippers as they are liable for any damage in transit.

Scope of delivery:

All Parts belonging to the standard scope of supply are attached to the instrument.

6. Mechanical connection

Before installation:

- Please ascertain whether the allowable maximum operating pressure and operating temperature of the instruments will not be exceeded (See Standard Material Combinations).
- The instrument should be installed in a vertical position in the pipework. The flow direction is from bottom to top.
- Remove all transport packing and ascertain that no packing material is left in the instrument.
- Sealing of the connection threads should be carried out with Teflon tape or similar.
- While mounting please check that there is no mechanical stress applied to the process connectors. We recommend a fastening of the input and output pipes approx. 50 mm in front of and behind the connectors.
- Do not install the instrument within an induction field.

Warning: When mounting the meters secure the process connectors by means of a suitable wrench. Failure to do so may result in a damage of the measuring glass.

- Check that the connection thread to pipe is fully sealed immediately after mechanical installation (See Commissioning of the Instruments).

Warning: With outside installation please keep in mind that the measuring glass may be destroyed at low temperatures by freezing of the medium.

7. Electrical connection

- Ensure that the power is disconnected during connection of the cable.
- Loosen the holding screw on the plug cap and remove the cap from the plug.
- Connect the power cable to the plug cap in accordance with the connection diagram below. Wiring for EX-Switches:

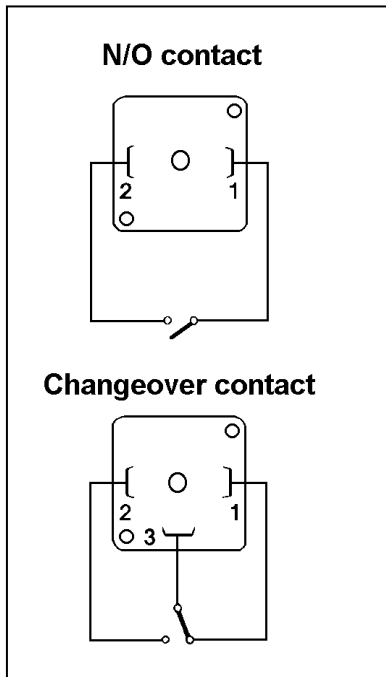

EX-N/O: brown / blue
 EX-SPDT: black / blue N/C

- Connect the plug to the contact connections and secure it with the holding screw.

Warning: The given electrical values of the reed contacts may not be exceeded even for short periods. For higher switching values we recommend contact protection relays or other contact protection measures.

- Following connection of the external equipment to the output and adjustment of the required switch points, the external power supply to the equipment may be switched on.

Examples for Contact Protection Measures

For capacitive and inductive loads (long cables and replays) we recommend protective switching.

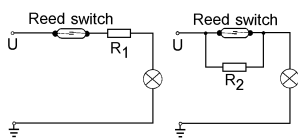

Lamp load with parallel or series resistance to the switch.

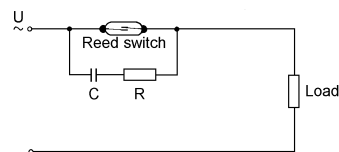

Protection with an RC circuit for a.c. current and inductive load.

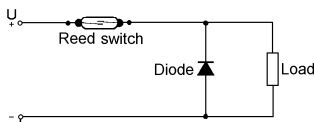

Protection with an idle diode for d.c. current and inductive load.

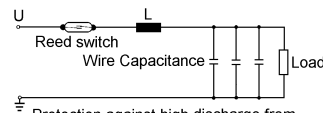

Protection against high discharge from condensers and loadcapacitances.

8. Commissioning of the Instruments

The use of this meter in machines acc. to directive 89/392/EWG is prohibited until the complete machine complies to this directive.

Adjustment of the limit values

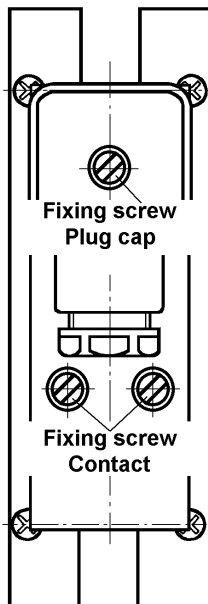

- Loosen the two fixing screws on the contact base.
- Slide the switch housing to the bottom stop.
- After loosening the holding screw, remove the plug cap from the contact base.
- Connect a suitable continuity meter to PIN 1+2 (changeover switch PIN 2+3).
- When the **instrument is installed**, open the inlet line and introduce the medium slowly until the top edge of the float indicates the required minimum flow volume. The reed contact is now closed (electrical continuity).

Warning: Sudden opening or closing of the flow line may result in pressure peeks several times higher than the system pressure. This may cause the destruction of the measuring glass.

- When the instrument is not yet installed, the float may be lifted with a suitable tool.
 - Push the switch housing to the top until the reed contact opens (no electrical continuity).
-
- Adjust the switch in this position by means of tightening the fixing screws.
 - Replace the plug cap and the instrument is now ready for operation.
 - If the limit switch is adjusted correctly, a bi-stable switch characteristic is achieved, i.e.: the contact remains closed when the float rises above the set limit value (PIN 1+2, or alternatively PIN 2+3).

Hysteresis

Hysteresis is characterised by the difference between the switching on and switching off points of the contact. By matching the magnet and reed contact sensitivity (AW Number) a hysteresis of approx. 6-10 mm way of float movement is achieved. At the same time it may be assured that the contacts have a bi-stable switching characteristic.

Exceeding the Measuring Range:

Warning: Continuously exceeding the measuring range together with pulsating flow results in the float hitting the upper stop continuously which can lead to increased wear in the instrument. When such cases occur, please contact the supplier.

The flow range may be exceeded by a large margin with a non-pulsating flow. Only a certain increase in pressure loss is experienced (The permissible maximum operating pressure must not be exceeded).

9. Maintenance

For measured media without contamination, the BVO or RVO instrument is almost maintenance-free. Where contamination or calcium or algae deposits are found on the internal parts, the instrument should be regularly cleaned.

The instrument may be removed from the pipe with a suitable open ended spanner. The internal parts are accessible for cleaning after removing the top connection. The internal parts may be cleaned with a suitable brush. After cleaning, the instrument should be reassembled in the correct manner. We recommend that the O - rings of the screwed connections are changed

10. Technical Specifications

Measurement and switch accuracy:	± 10 % of full scale value
Max. Operating Pressure:	10 bar
Max. Medium Temperature:	100° C
Protection acc. to EN 60529:	IP 65
Approvals:	SEV, UL, CSA
Electrical Switch Values	
N/O:	240 VAC, 100 VA, 1.5 A (SEV, CSA)
SPDT:	240 VAC, 60 VA, 1 A (SEV, CSA)
N/O, EEx d IIC T6:	250 VAC, 2 A, 80 VA
SPDT EEx d IIC T6:	250 VAC, 1 A, 60 VA

For instruments with UL-approval, see switch values on contact housing.

11. Dimensions and Pressure Losses

Instrument size	SW	G	L (mm)	B (mm)	T (mm)	D (mm)
BVO-..01 to BVO-..10	32	1/4 (1/2)	135	39	39	---
BVO-..16	32	1/2 (3/4)	164	39	39	---
BVO-..50	41	3/4 (1)	163 (174)	45	45	---
RVO-..01 to RVO-..02	32	1/4	135	---	---	43
RVO-..06 to RVO-..10	32	1/4 (1/2)	135	---	---	43
RVO-..16	32	1/2 (3/4)	165	---	---	43
RVO-..55	41	3/4 (1)	163 (174)	---	---	48

* without switch, with switch add 52,5 mm

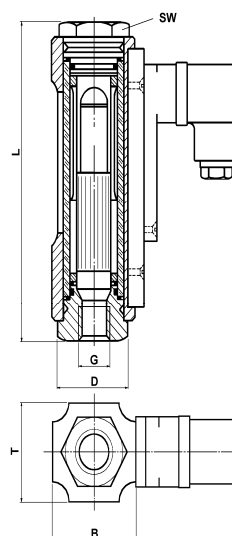

12. Recommended Spare Parts

Only the parts of the instruments and the materials are listed. Depending on the instrument model, the parts are available in different sizes (When ordering please give the instrument model).

- | | |
|------------------------------------|--------------------------------|
| 1.1 Float Brass | 4.1 Contact (Normally open) |
| 1.2 Float Stainless Steel | 4.2 Contact (SPDT) |
| 2.1 Slotted nozzle Brass | 4.3 Ex-contact (Normally open) |
| 2.2 Slotted nozzle Stainless Steel | 4.4 Ex-contact (SPDT) |
| 3.1 O-Ring set Perbunan | 5.1 Spare glass with scale |
| 3.2 O-Ring set Viton | |

13. EU Declaration of Conformance

We, KOBOLD-Messring GmbH, Hofheim-Ts, Germany, declare under our sole responsibility that the product:

Flowmeter and switch Model BVO and RVO

to which this declaration relates is in conformity with the standards noted below:

EN 61010-1:2010

Safety requirements for electrical equipment for measurement, control and laboratory use - Part 1: General requirements

EN 60529:2014

Degrees of protection provided by enclosures (IP Code)

Also the following EC guidelines are fulfilled:

2014/35/EU
2011/65/EU

Low Voltage Directive
RoHS

Hofheim, 6. April 2016



H. Peters
General Manager



M. Wenzel
Proxy Holder