

Operating Instructions for Full Metal Variable Area Flow Meter and Counter

Model: BGN



Order from: **C A Briggs Company**

622 Mary Street; Suite 101; Warminster, PA 18974

Phone: 267-673-8117 - Fax: 267-673-8118

Sales@cabriggs.com - www.cabriggs.com

Contents

1	IDENTIFICATION	4
1.1	Supplier/manufacturer	4
1.2	Product type.....	4
1.3	Product name.....	4
2	APPLICATIONS	4
3	OPERATIONAL MODE AND SYSTEM DESIGN.....	4
3.1	Measuring principle	4
3.2	System design.....	4
4	INPUT 4	
4.1	Measured variable.....	4
4.2	Measuring range (lower-range and upper-range value).....	4
5	OUTPUT6	
5.1	Binary output.....	6
5.1.1	KEI 1 or KEI 2 limit transducers.....	6
5.1.2	KEM 1 or KEM 2 limit transducers (special version).....	6
5.2	Analog output with the ES magneto-electric transmitter	6
5.3	Analog output with the KINAX 3W2 angle-of-rotation transmitter	6
6	CHARACTERISTIC VALUES.....	6
6.1	Measuring accuracy	6
6.1.1	Reference conditions	6
6.1.2	Measured error	6
6.1.3	Repeatability.....	6
6.2	Influence of ambient temperature	6
6.3	Influence of fluid temperature	6
7	CONDITIONS OF USE	6
7.1	Mounting requirements	6
7.1.1	Mounting/start-up	7
7.1.2	Device settings	7
7.1.3	Adjusting the limit transducer	7
7.1.4	Operation in hazardous areas.....	8
7.2	Ambient conditions	9
7.2.1	Ambient temperature ranges.....	9
7.2.2	Storage temperature.....	9
7.2.3	Climatic category	9
7.2.4	Degree of protection.....	9
7.2.5	Shock resistance/vibration resistance	9
7.2.6	Electromagnetic compatibility.....	9
7.3	Fluid conditions	9
7.3.1	Fluid temperature ranges	9
7.3.2	Diagrams: Max. ambient temperature based on the fluid temperature for the ES.....	9
7.3.3	Fluid pressure limit.....	10
7.3.4	Inlet and outlet sections	10
7.3.5	Physical state	10
7.3.6	Density	10
7.3.7	Viscosity.....	10
7.3.8	Pressure (for gas measurement).....	10
7.3.9	Pressure loss	10
8	CONSTRUCTION DETAILS.....	11
8.1	Type of construction/dimensions	11

8.1.1	Aluminum indicator housing	11
8.1.2	Dimension drawing for heating connection.....	11
8.1.3	Indicator housing made of stainless steel	12
8.2	Weight	12
8.3	Material.....	13
8.4	Process connection	13
8.5	Magnetic filter	13
8.6	Electrical connection.....	14
8.6.1	Wiring diagram for ES transmitter (signal output 4-20 mA with HART®).....	14
8.6.2	Wiring diagram for ES transmitter with 4-20 mA output and 2 limit transducers	14
8.6.3	Wiring diagram for ES transmitter with 4- 20 mA output, pulse output and limit transducer	15
8.6.4	Wiring diagram for inductive limit transducers.....	15
8.6.5	Wiring diagram for KINAX 3W2 transmitter with 4-20 mA output, 2 wires	16
8.6.6	Wiring diagram for KINAX 3W2 transmitter with 4-20 mA output, 3 wires	16
8.6.7	Wiring diagram for KINAX 3W2 transmitter with 4-20 mA output, 4 wires	17
8.6.8	Wiring diagram for KEM 1 and KEM 2 double-throw microswitches	17
9	INDICATOR UNIT	18
10	AUXILIARY POWER	18
11	CE MARK	18
12	ORDER INFORMATION.....	18
12.1	Available accessories	18
13	STANDARDS AND DIRECTIVES, CERTIFICATES AND APPROVALS.....	18
14	SAFETY INSTRUCTIONS	18
14.1	Intended use	18
14.2	Installation, start-up and operating personnel	18
15	PACKAGING, MOUNTING AND SHIPMENT	18
16	MAINTENANCE.....	18
17	INSTALLING AND REMOVING CONE, FLOAT, DAMPING SETS/SPRING STOP.....	19
18	TROUBLE SHOOTING.....	19
19	RETURNING DEVICES FOR REPAIR AND SERVICE	19
20	REPLACEMENT PARTS.....	19
21	EXPLODED VIEWS.....	20
21.1	Fitting with measuring element.....	20
21.1.1	BGN-.... Standard version	20
21.1.2	BGN-.... with spring stop	20
21.1.3	BGN-.... with damping piston	20
21.1.4	BGN-.... with damping piston and spring stop	21
21.1.5	BGN-.... small measuring ranges.....	21
21.2	Indicator unit.....	22
21.2.1	Complete indicator unit, local with scale	22
21.2.2	Complete indicator unit with 1 SJ 3,5 N limit transducer	22
21.2.3	Complete indicator unit with 2 SJ 3,5 N limit transducers.....	22
21.2.4	Complete indicator unit with E2 KINAX Ex transmitter	23
21.2.5	Complete indicator unit with E2 KINAX Ex transmitter and 1 SJ 3,5 N limit transducer.....	23
21.2.6	Indicator unit with transmitter type ES Ex HART®	23
22	DECONTAMINATION CERTIFICATE FOR DEVICE CLEANING	24
23	EC TYPE EXAMINATION CERTIFICATE.....	25
24	SALES REPRESENTATIVES	30
25	NOTES30	

Introduction

These Installation and Operating Instructions serve as a tool for the correct installation, operation and maintenance of the device. They are a supplement to the BGN Device Description. Read the manual carefully before the device is installed and put into use. It does not include special versions or applications.

All devices are thoroughly checked for order compliance and operability before delivery. Upon receipt, please conduct a visual inspection of possible damage that may be identified as having occurred during shipment. If you discover any defect, please contact our head office in Cologne or the local sales office responsible for your area (see the telephone directory at the end of this manual or on our Web site). Apart from a description of the error, we will need the equipment type and serial number of the delivery.

Kobold Messring shall not furnish guarantee for any repair work done without prior notice. Unless otherwise agreed on, the rejected parts must be made available to us in case a claim is made.

1 Identification

1.1 Supplier/manufacturer

Kobold Messring GmbH
 Nordring 22 - 24 ·
 D-65719 Hofheim/Taunus
 Phone +49 (0) 6192 299-0
 Fax +49 (0) 6192 23398
 Internet: <http://www.kobold.com>
 E-mail: <mailto:info.de@kobold.com>

1.2 Product type

Flowmeter in all-metal design based on the float principle

1.3 Product name

BGN with subgroups
 BGN-S (stainless steel)
 BGN-P (PTFE)
 BGN-H (Hastelloy)

2 Applications

The BGN meter is suitable for flow measurement of liquid or gaseous products in pipes. It shows the current flow rate in volume or mass per unit in time.

Applications: flow measurement, dosing, monitoring, adjusting and control of liquid and gaseous products. The meter's design makes it ideal for processes under difficult and adverse operating conditions.

The devices are available with additional electrical equipment for process monitoring and control.

3 Operational mode and system design

3.1 Measuring principle

The measuring element consists of a sharp-edged measuring ring (1) and a conical float (2). A medium flows from the bottom to the top through the measuring ring, lifting the float until the buoyancy force (A) and the weight of the float (Gs) establish equilibrium. As the height of the float varies, an annular clearance (S) proportional to the flow appears between the float and the measuring ring. The height of the float in the measuring ring is a measure of the flow. The permanent magnet (3) embedded in the float then transmits this measure to the scale and the optional electronic evaluators through a magnet tracking indicator system (4).

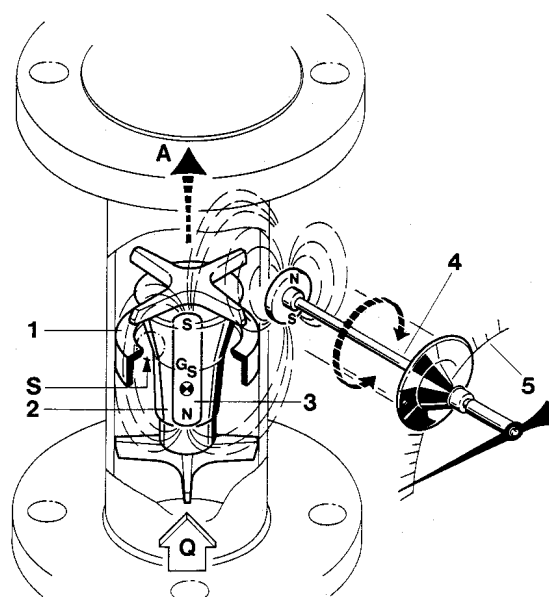

3.2 System design

The meter consists of a cylindrical fitting pipe with flange connections on both sides. For the measuring range from 5 to 50 l/h, a measuring ring is inserted in the tube in which a conical float can move with vertical freedom. For small measuring ranges of up to 4–40 l/h, the measuring cell consists of a conical measuring tube with cylindrical float.

The height of the float resulting from the flow rate is transmitted in a rotary motion by a built-in permanent magnet through a magnet tracking indicator system in a rotation to the pointer axis of the analog indicator unit.

4 Input

4.1 Measured variable

Volume flow

4.2 Measuring range (lower-range and upper-range value)

The lower-range value is considered 10 % of the upper-range value. Measuring range span: 10-100 %
 Smallest measuring range: 0.5-5.0 l/h water
 Largest measuring range: 8.000-80.000 l/h water (stainless steel)

Measuring range table							
Nominal size (DN)	Measuring range	Measuring range for water at 1000 kg/m ³		Measuring range for air at 1.013 bars absolute pressure		Pressure loss (mbar)	Remarks
15	A	0.5 – 5.0	l/h	0.015 – 0.15	m ³ /h	40	1)+2)
	B	1.0 – 10	l/h	0.03 – 0.30	m ³ /h	44	1)+2)
	C	1.6 – 16	l/h	0.045 – 0.48	m ³ /h	40	1)+2)
	D	2.5 – 25	l/h	0.075 – 0.75	m ³ /h	40	+2)
	E	4.0 – 40	l/h	0.13 – 1.3	m ³ /h	40	+2)
	F	5.0 – 50	l/h	0.15 – 1.5	m ³ /h	40	
	G	7.0 – 70	l/h	0.2 – 2.1	m ³ /h	40	
	H	10 – 100	l/h	0.3 – 3.0	m ³ /h	60	
	I	16 – 160	l/h	0.5 – 4.6	m ³ /h	60	
	J	25 – 250	l/h	0.7 – 7.0	m ³ /h	60	
	K	40 – 400	l/h	1.0 – 11	m ³ /h	70	
	L	60 – 600	l/h	1.7 – 17	m ³ /h	80	
	M	100 – 1000	l/h	3 – 30	m ³ /h	60	5)
	N	160 – 1600	l/h	4 – 46	m ³ /h	70	5)
P	250 – 2500	l/h	7 – 70	m ³ /h	100	5)	
25	A	0.5 – 5.0	l/h	0.015 – 0.15	m ³ /h	40	1)+2)
	B	1.0 – 10	l/h	0.03 – 0.30	m ³ /h	40	1)+2)
	C	1.6 – 16	l/h	0.045 – 0.48	m ³ /h	40	1)+2)
	D	2.5 – 25	l/h	0.075 – 0.75	m ³ /h	40	+2)
	E	4.0 – 40	l/h	0.13 – 1.3	m ³ /h	40	+2)
	F	5.0 – 50	l/h	0.15 – 1.5	m ³ /h	40	
	G	7.0 – 70	l/h	0.2 – 2.1	m ³ /h	40	
	H	10 – 100	l/h	0.3 – 3.0	m ³ /h	60	
	I	16 – 160	l/h	0.5 – 4.6	m ³ /h	60	
	J	25 – 250	l/h	0.7 – 7.0	m ³ /h	60	
	K	40 – 400	l/h	1.0 – 11	m ³ /h	70	
	L	60 – 600	l/h	1.7 – 17	m ³ /h	80	
	M	100 – 1000	l/h	3 – 30	m ³ /h	60	
	N	160 – 1600	l/h	4 – 46	m ³ /h	70	
P	250 – 2500	l/h	7 – 70	m ³ /h	100		
Q	400 – 4000	l/h	11 – 110	m ³ /h	240	3)+ 4)	
40	P	250 – 2500	l/h	7 – 70	m ³ /h	50	3)
	Q	400 – 4000	l/h	11 – 110	m ³ /h	120	3)
	R	600 – 6000	l/h	17 – 170	m ³ /h	180	3)
50	Q	400 – 4000	l/h	11 – 110	m ³ /h	80	
	R	600 – 6000	l/h	17 – 170	m ³ /h	90	
	S	1000 – 10000	l/h	29 – 290	m ³ /h	110	
	T	1600 – 16000	l/h	46 – 460	m ³ /h	230	
	U	2500 – 25000	l/h	70 – 700	m ³ /h	500	3)+ 4)
80	T	1600 – 16000	l/h	46 – 460	m ³ /h	70	
	U	2500 – 25000	l/h	70 – 700	m ³ /h	100	
	V	4000 – 40000	l/h	110 – 1100	m ³ /h	350	
100	V	4000 – 40000	l/h	110 – 1100	m ³ /h	120	
	W	6000 – 60000	l/h	170 – 1700	m ³ /h	360	
	X	8000 – 80000	l/h	240 – 2400	m ³ /h	600	3)+ 4)

- 1) for P version (PTFE), float with tantalic collar, cone of borosilicate glass
measuring range: A 0.7–7.0 l/h, B 1.2–12 l/h, C 2.0–20 l/h
- 2) gas throttle in S version for gas measurement included in price (pressure loss 200 mbar)
- 3) not available in P version
- 4) conversion not possible
- 5) only in S and H version, only with smaller sealing strip

5 Output

Various electrical contact makers or transmitters may be installed in the indicator unit.

5.1 Binary output

Using the segments of the slot-type initiators or the eccentric discs of the microswitches, any switching point between 10 % and 90 % of the flow rate can be set.

5.1.1 KEI 1 or KEI 2 limit transducers

1 or 2 limit transducers,
type SJ 3,5N, make Pepperl+Fuchs
(special switch possible, e.g. SN version)
Safety class: PTB Nr. 99 ATEX 2219 X
PTB Nr. 00 ATEX 2048 X

5.1.2 KEM 1 or KEM 2 limit transducers (special version)

Double-throw microswitches whose switching point is activated by a cam plate.

KEM 1 = 1 Double-throw microswitch
KEM 2 = 2 Double-throw microswitches

Maximum make-break capacity:

230 VAC 50/60Hz	6 A
24 VDC	0.5 A
110 VDC	0.2 A

5.2 Analog output with the ES magneto-electric transmitter

The magneto-electric transmitter is factory-calibrated to the scale values upon shipment. The signal output is supplied exclusively in a two-wire connection at 4-20 mA. Normally, the 4-20 mA signal has the HART® protocol; alternatively it can have PROFIBUS PA.

Additional options: 2 limit values, alternatively 1 limit value and 1 pulse output

The signal output and the limit values can be configured using a HART® modem operating on the following configuration programs: SensorPort from Bopp & Reuther, PDM from Siemens or AMS from Rosemount. Furthermore, a HART® hand-held terminal (with DD software) can also be used. For more information about configuration, please refer to the separate Operating Instructions for the ES.

Safety class: DMT 00 ATEX 075 / II2G EEx ia IIC T6

When installing electrical equipment in hazardous areas, the conditions and provisions specified in the approval documents must be followed.

5.3 Analog output with the KINAX 3W2 angle-of-rotation transmitter

The signal output of the angle-of-rotation transmitter is factory-calibrated to the scale values. The signal output is 4-20 mA in 2-wire connection; or alternatively 0-20 mA in 4- or 3-wire connection. The signal output of 4 mA corresponds to the flow rate scale value of 0 (0 mA for the 0-20 mA version). 5.6 mA corresponds to 10 % of the flow rate scale value (2 mA). 20 mA corresponds to 100 % of the flow rate scale value.

Use in hazardous areas:

The angle-of-rotation transmitter is a component approved for hazardous areas. When used in hazardous areas, all the values and instructions indicated in the certificate of approval must be observed. Auxiliary power is fed through an approved intrinsically safe circuit of 12-30 V. To prove intrinsic safety, only authorized electrical equipment may be interconnected. Please take note of the maximum permissible ambient temperature of 60 °C/75 °C for the transmitter and the process temperature.

Safety class:

PTB 97 ATEX 2271 / II 2G EEx ia IIC T6

6 Characteristic values

6.1 Measuring accuracy

6.1.1 Reference conditions

Water 20 °C

6.1.2 Measured error

(for liquids)
BGN-S/H/P +/- 1.6 % of URV for local display
(URV = upper-range value)

(for gases)
BGN-S/H/P +/- 2.0 % of URV for local display

Additional inaccuracy for:

ES = +/- 0.2 %
KINAX 3W2 = +/- 0.5 %

6.1.3 Repeatability

+/- 0.5 % of upper-range value

6.2 Influence of ambient temperature

- Without electrical equipment and with limit transducer without influence
- With KINAX transmitter:
+/- 0.2 % / 10 K reference temperature 23 °C
- With ES transmitter:
+/- 0.5 % / 10 K reference temperature 22 °C

6.3 Influence of fluid temperature

Deviations in fluid temperature from the temperature observed during calibration can result in a proportional display fault because of the corresponding change in density. Changes in viscosity cause a non-linear display fault.

7 Conditions of use

The VDI/VDE guidelines 3513, Sheet 3, must be observed. The meter is suitable for :

- Liquids with sufficient flowability that are free of solids, do not bond and do not tend to settle.
- Gases with linear flow behavior and an adequate inlet pressure.

7.1 Mounting requirements

The mounting location must be suitable for a vertical direction of flow from the bottom to the top.

Important: If that is impossible, then the device type **BGF** may be utilized. This device can be used for both horizontal and vertical direction of flow.

The limit values for temperature and air humidity at the mounting location must be maintained. Avoid corrosive atmospheres. If this cannot be avoided, ventilation must be installed.

Please make sure that there is adequate clearance from parts that might cause magnetic interferences such as solenoid valves and ferromagnetic components like steel brackets/supports. We recommend that the minimum lateral distance between two adjacently mounted devices be **300 mm**. The devices can be mounted close together if vertically offset by one device length. The minimum lateral clearance for interfering steel parts should be **200 mm**. In case of doubt, check the interference by moving the device back and forth in the selected distance by about 200 mm and testing whether the pointer position changes.

Select the mounting location so as to enable a reliable reading of the scale values. Please take note as well of the space requirement for any possible disassembly of the device. As a rule, inlet and outlet sections in front of and behind the device are unnecessary if the medium has a linear flow profile. Avoid mounting accessories converging on one side in front of the device. However, if this is indispensable maintain a minimum device length of 250 mm as an inlet section.

The nominal size of the pipes to be connected must correspond to that of the meter. Avoid fittings converging on one side directly in front of the device. As a rule, install valves behind the measuring equipment if there are gases involved.

7.1.1 Mounting/start-up

The device must be mounted in accordance with the direction of flow from the bottom to the top (perpendicularly). Please observe the prior reference to the BGF-type device.

The nominal size of the device and that of the pipes must be the same. The pressure stages and, hence, the dimensions of the flanges must coincide. The surface roughness of the flange sealing surface must be suitable for the prescribed gaskets.

Please check whether possible accessories like spring stops, gas/liquid-type dampers are still correctly sitting on the flange. Check whether the mounting clearance between the flanges of the pipes corresponds to the assembly dimension of the device plus two gaskets. To achieve stress-free mounting, the flanges of the pipes must be aligned parallel to each other.

Use connecting bolts and gaskets in the prescribed dimensions. The gaskets must be suitable for the operating pressure, the temperature and the measured medium. With PTFE-coated devices, use gaskets whose interior and exterior diameter correspond to the sealing strip of the device.

Tighten the screws crosswise so that the process connections are tight. See to the tightening torques of screws especially with PTFE-coated devices.

The maximum torques for PTFE-coated devices are:
DN15/DN25 = 14 Nm/DN50 = 25 Nm/DN80 = 35 Nm/DN100 = 42 Nm (following VDI/VDE Guideline 3513).

Please check whether the pipe is adequately stable to rule out the possibility of vibration or swinging of the device. (Do not use steel mounting parts on the device.)

When gas is used as the medium, pay special attention to the position of the valve. If the device is calibrated to more than 1.013 bars absolute pressure, the valve is usually installed behind the flowmeter. At 1.013 bars absolute pressure (free exhaust) install it in front of the device.

If there is risk of dirt or solid matter penetrating the process pipes, flush them beforehand so that these materials do not get caught in the device. Ferromagnetic solid matter such as spatter can lead to the breakdown of the device. If these materials are still present during normal operating conditions, mount a magnetic filter (accessory) in front of the device. When using liquids, flush to avoid a surge of gas bubbles. Slowly increase the supply pressure when using gases to prevent pressure surges. Basically, avoid activation using solenoid valves to prevent the float from shooting upwards.

7.1.1.1 Gas measurement

When using gases, slowly let the operating pressure rise. At the same time, vary the operating pressure through a setting valve so that the float is not knocked around since otherwise this would damage the measuring element.

7.1.2 Device settings

The measuring equipment is delivered ready for operation according to your order specifications. **The limit transducers** are set to the desired values. If you have submitted no requirements, the basic setting for

1 contact device: - Minimum contact switching point at 10 % of descending flow (damped/closed-circuit principle).

2 contact devices: Minimum contact switching point at 10 % of descending flow and maximum contact switching point at 90 % of ascending flow.

7.1.3 Adjusting the limit transducer

The contacts are adjustable through the contact position indicators located on the scale. Dismantle the indicator cover, unfasten the contact position indicators, set to the desired value and reattach them.

7.1.4 Operation in hazardous areas

7.1.4.1 Without electrical equipment

The basic version of the flowmeter is a *non-electrical device* without its own ignition sources and meets DIN EN 13463-1 requirements. It can be used in hazardous areas that require Category 2 equipment.

Marking:



II 2GD c

Reg. No.: BVS 03 ATEX H/B 112

Tech. File Ref. 03-02 X

Since the device does not have its own power sources that would result in a temperature increase, the fluid temperature is decisive for the maximum surface temperature.

When used in potentially explosive dust atmospheres, the device must be cleaned regularly in order to avoid deposits exceeding 5 mm.

7.1.4.2 With built-in electrical limit transducers

When the limit transducers are installed, the device becomes an electrical assembly and receives a marking in accordance with DIN EN 50014 from the entire device with the built-in electrical limit transducers.

The electrical and thermal data and the special conditions of the EC Type Examination Certificate of the built-in limit transducers must be observed (see also the diagram in Section 7.3.2).

The influence of the fluid temperature on the built-in limit transducers must be observed. The overtemperature of the maximum fluid temperature based on the maximum ambient temperature must be considered with a factor according to the following table:

Nominal size	Factor for standard version	Factor for the device with the indicator pulled forward
DN15 and DN25	0.2	0.07
DN40 and DN50	0.25	0.085
DN80 and DN100	0.3	0.1

Example for built-in limit transducer for DN 15 and DN 25:

Max. ambient temperature $T_{amb} = 40\text{ °C}$
 Max. fluid temperature $T_m = 120\text{ °C}$
 Factor for brought-in heat $F = 0.2$
 Temperature class T4

$T_{ü} =$ Overtemperature
 $T_a =$ Ambient temperature of limit transducer

$$T_{ü} = T_m - T_{amb} = 120\text{ °C} - 40\text{ °C} = 80\text{ °C}$$

$$T_a = T_{ü} * F + T_{amb} = 80\text{ °C} * 0,2 + 40\text{ °C} = 56\text{ °C}$$

In accordance with the tables in the PTB 99 ATEX 2219 X EC Type Examination Certificate, the SJ 3,5... N... inductive sensor must be operated in the T5 temperature class with an intrinsically safe circuit that does not exceed the maximum values of the Type 3 circuit.

When using the device in hazardous areas, follow the applicable national installation rules.

Example for calculating the max. fluid temperature based on the max. ambient temperature for the built-in sensor Type ES for DN 15/25.

$T_a = 70\text{ °C}$
 $T_{amb} = 60\text{ °C}$
 $F = 0.2$

$$T_m = \left(\frac{T_a - T_{amb}}{F} \right) + T_{amb} = \left(\frac{70\text{ °C} - 60\text{ °C}}{0,2} \right) + 60\text{ °C} = 110\text{ °C}$$

7.1.4.2.1 Marking for the device when the SJ 3,5...N... limit transducer is built in



PTB 99 ATEX 2219 X
 II 2G EEx ia IIC T6-T4

7.1.4.2.2 Marking for the device when the ES magneto-electric transmitter is built in



DMT 00 ATEX 075
 II2G EEx ia IIC T6

7.1.4.2.3 Marking for the device when the KINAX 3W2 angle-of-rotation transmitter is built in



PTB 97 ATEX 2271
 II 2G EEx ia IIC T6

7.1.4.3 Atmospheric conditions

In accordance with EN 1127, a "potentially explosive atmosphere" is defined as a mixture of air and combustible gases, vapour, mist or dust under atmospheric conditions. Such conditions are defined in EN 13463-1, para. 1, with values $T_{atm} = -20\text{ °C}$ to $+60\text{ °C}$ and $P_{atm} = 0.8$ to 1.1 bar. Outside this range, safety parameters for most ignition sources are not available.

Usually, variable-area flow meters operate under operating conditions outside the atmospheric conditions of 0.8 to 1.1 bar. Irrespective of the zone classification – safety parameters of explosion protection – are basically not applicable to the inside of the measuring tube.

Therefore operation with combustible products is only allowed if a potentially explosive air mixture is not formed inside the flow meter. Where this condition is not met, the operator will need to assess the ignition hazard in each individual case and give due consideration to existing parameters (e.g. pressure, temperature, process product, materials of construction for the measuring tube).

7.1.4.4 Ground connection

In variable-area flow meters, it is possible under operating conditions for charge separation to occur in the measuring tube due to the transport of non-conductive fluids and/or when the flow comes into contact with non-conductive internals (e.g. liners, floats).

For that reason, variable-area flow meters must be permanently grounded by the operator by way of the process connections (flanges) in order to discharge electrostatic build-up. The operator is also responsible for extending the ground continuity of the process pipeline.

If grounding cannot be made via the process connections (plastic process connections or undefined connections), the flow meter must be connected to the local ground potential via the flanges. This connection only ensures electrostatic grounding of the device and does not meet the requirements for equipotential bonding.

7.2 Ambient conditions

7.2.1 Ambient temperature ranges

Without electrical accessories:

-40 °C to +80 °C

With limit transducer:

-40 °C to +65 °C

With KINAX signal output:

-40 °C to +60 °C

With ES signal output:

-40 °C to +70 °C

For the hazardous area version, take note of the maximum ambient temperatures depending on the temperature class as specified in the Type Examination Certificate.

7.2.2 Storage temperature

The storage temperatures are identical to the ambient temperature ranges.

7.2.3 Climatic category

Weather-protected and/or unheated locations, class C according to IEC 654 Part 1

7.2.4 Degree of protection

IP 65 (Aluminum indicator unit)

IP 67 (Stainless steel indicator unit)

7.2.5 Shock resistance/vibration resistance

The meter should be protected from extreme shocks and vibrations, which could cause damage.

7.2.6 Electromagnetic compatibility

EN 61000-6-2:1999 Immunity industrial environment

EN 50081-1 Emitted interference residential environment

EN 55011:1998+A1:1999 Group 1, Class B

NAMUR recommendation NE 21

7.3 Fluid conditions

7.3.1 Fluid temperature ranges

BGN-S/H : - 40 °C to +200 °C

Special design: -80 °C to +350 °C

BGN-P : - 20 °C to +125 °C

7.3.2 Diagrams: Max. ambient temperature based on the fluid temperature for the ES

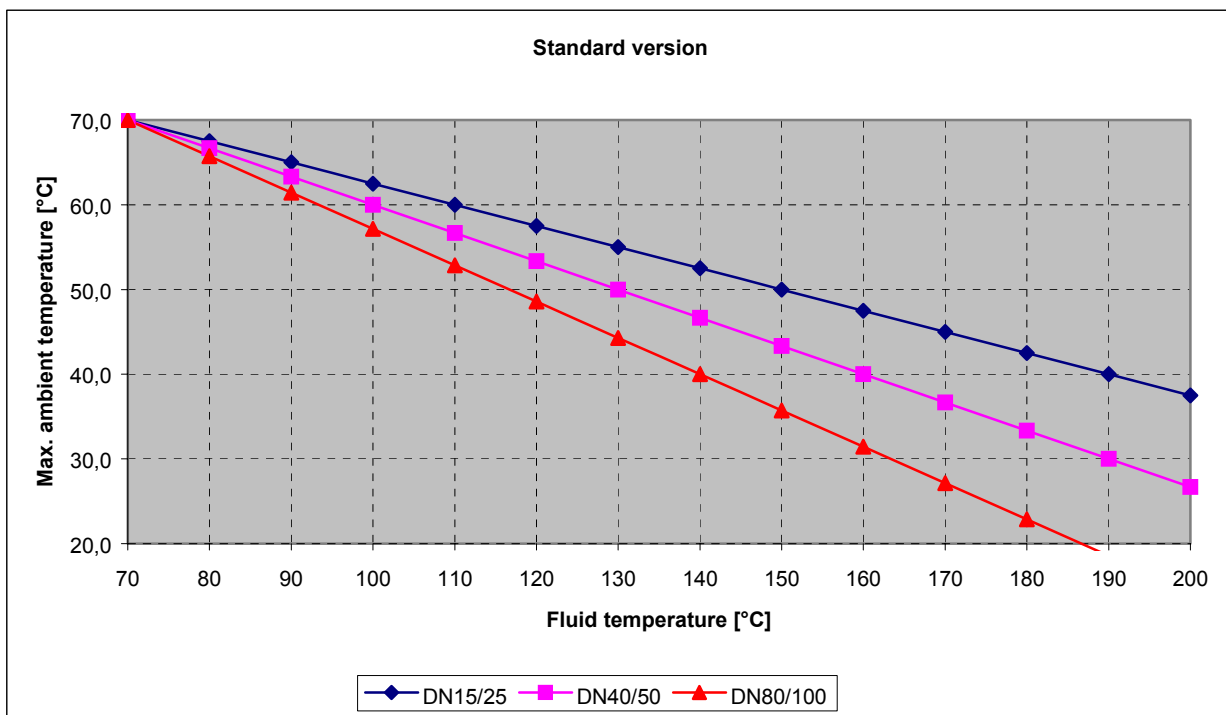

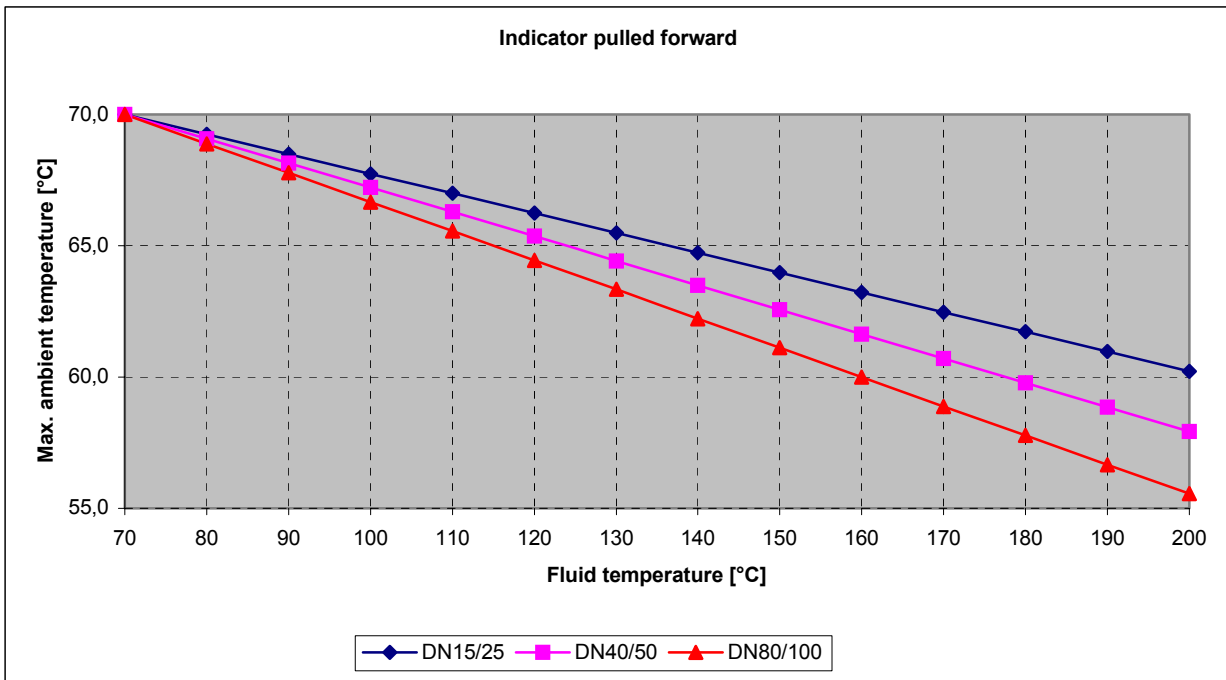

7.3.3 Fluid pressure limit

Standard design BGN-S/H – DN 15/25/40/50/80 PN 40;
 DN 100 PN 16
 Special design – up to PN 400
 BGN-P – DN 15/25/50/80/100 PN 16

7.3.4 Inlet and outlet sections

Inlet and outlet sections are not required for a linear flow profile of the fluid. For an extremely non-linear flow profile (e.g. shut-off/control valves are located in front of the meter), we recommend an inlet section with a mounting length of 250 mm (see also guidelines in accordance with VDI/VDE 3513).

7.3.5 Physical state

Liquid or gaseous

7.3.6 Density

Liquids: up to 2.0 kg/l
 Gases: no restrictions

7.3.7 Viscosity

The influence of viscosity depends on various factors. Therefore, it must be calculated for each application.

7.3.8 Pressure (for gas measurement)

The measured values only apply to the calibrated fluid data stated on the scale. Any change or deviation in pressure will cause a display fault.

7.3.9 Pressure loss

Depends on the meter size and the measuring range (see Measuring range table).

8 Construction details

8.1 Type of construction/dimensions

8.1.1 Aluminum indicator housing

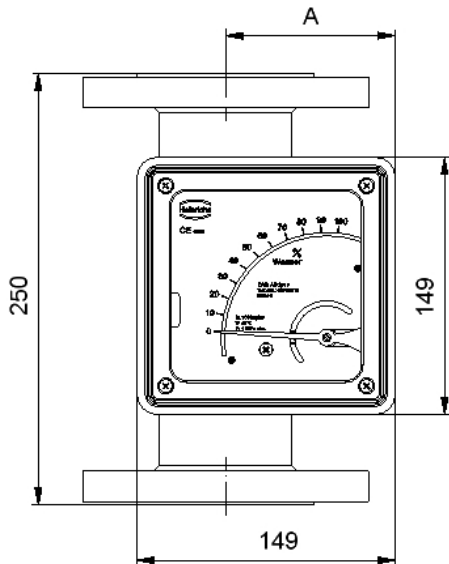

8.1.2 Dimension drawing for heating connection

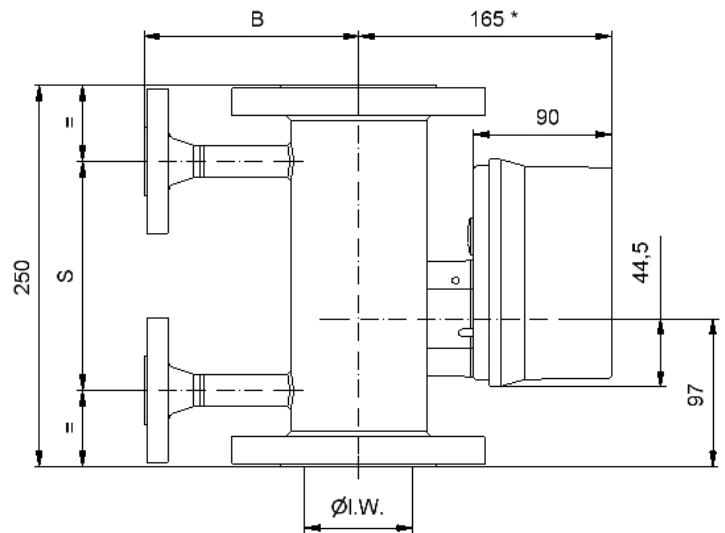
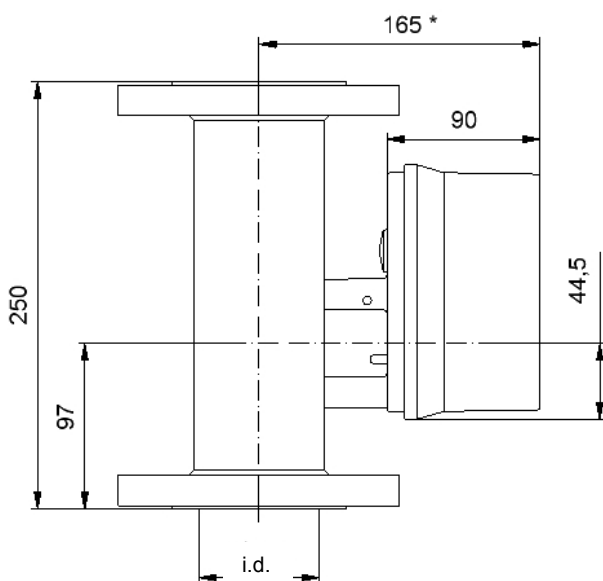
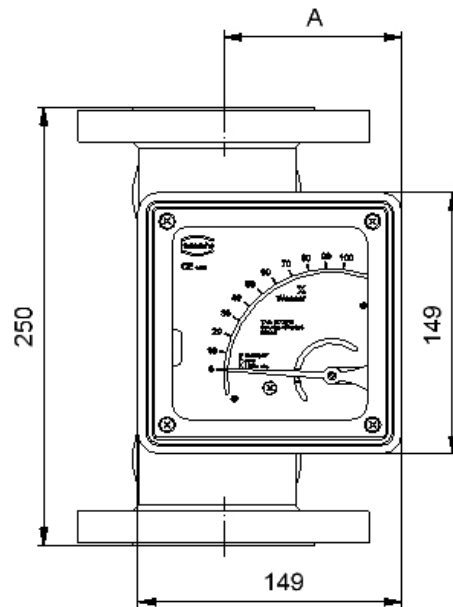

Dimensions:

DN	PN	i.d.	A	B _{Flange}	B _{Ermeto}	S
15	40	26	74	110	53	150
25	40	32	77	110	58,5	150
40	40	46	88	130	63	150
50	40	70	97	140	77,5	150
80	16	102	113	160	93,5	150
100	16	125	126	175	110	120

Deviating mounting dimensions:

* +100 mm with the indicator pulled forward

8.1.2.1 Connections for heating jacket

Pipe for	Ermeto 12 mm
Flange in acc. with DIN	DN 15 or DN 25 PN 40
Flange in acc. with ANSI	1/2" 150 lbs

The DN 25 flange is a special version.

8.1.3 Indicator housing made of stainless steel

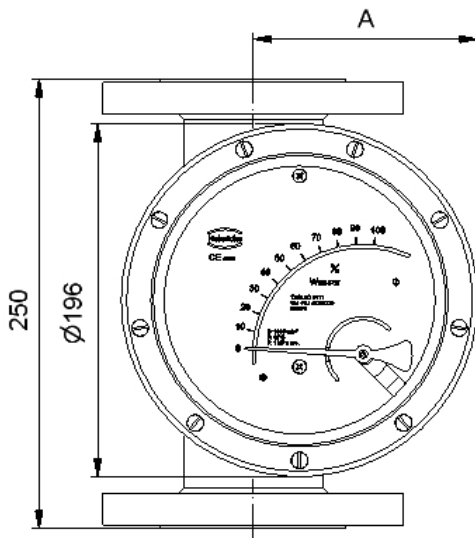

8.2 Weight

Nominal size	Weight [kg]
DN 15	3
DN 25	4.2
DN 40	6
DN 50	7.5
DN 80	13
DN 100	18

Nominal size	Weight [kg]
3/4", 150 lbs, ANSI B16.5	3
1", 150 lbs, ANSI B16.5	4.2
1 1/2", 150 lbs, ANSI B16.5	6
2", 150 lbs, ANSI B16.5	7.5
3", 150 lbs, ANSI B16.5	13
4", 150 lbs, ANSI B16.5	18

Nominal size	Weight [kg]
3/4", 300 lbs, ANSI B16.5	3.4
1", 300 lbs, ANSI B16.5	4.7
1 1/2", 300 lbs, ANSI B16.5	6.8
2", 300 lbs, ANSI B16.5	8.5
3", 300 lbs, ANSI B16.5	14.5
4", 300 lbs, ANSI B16.5	20

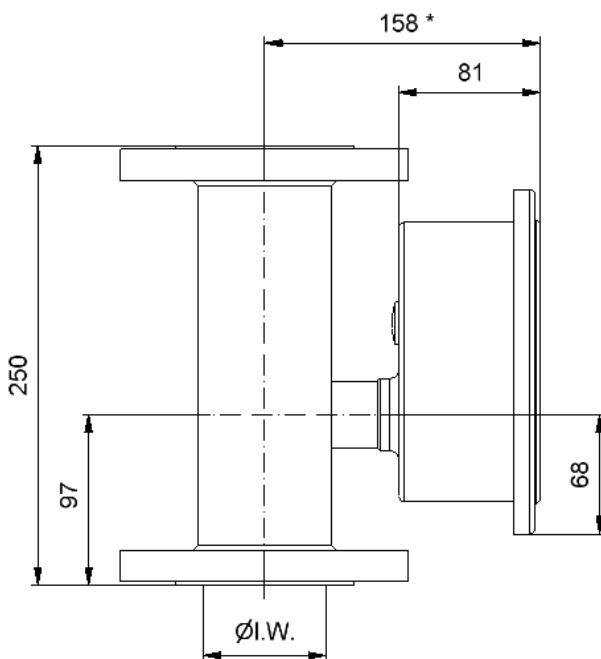

i.d. = inside diameter

DN	PN	Inside diameter	A
15	40	26	100
25	40	32	103
40	40	46	110
50	40	70	122
80	16	102	138
100	16	125	151

Deviating mounting dimensions:

* +100 mm with the indicator pulled forward

8.3 Material

Fitting

Type	Measuring tube	Lining of measuring tube	Flanges	Flange lining	Float
BGN – S	Stainless steel	none	Stainless steel	none	Stainless steel
BGN – P	Stainless steel	PTFE	Stainless steel	PTFE	PTFE
BGN – H DN15/25 3/4"/1"	Hastelloy HC4	none	Hastelloy HC4	none	Hastelloy HC4
BGN – H > DN40 / 1 1/2"	Hastelloy HC4	none	Stainless steel	Hastelloy HC4	Hastelloy HC4

Indicator

Type	Base plate	Housing
BGN – S/P/H	Aluminum	Aluminum, safety glass window
Optional	Stainless steel	Stainless steel, safety glass window

8.4 Process connection

	BGN-S/H	BGN-P
DN 15	PN 40	PN 16
DN 25	PN 40	PN 16
DN 40	PN 40	PN 16
DN 50	PN 40	PN 16
DN 80	PN 40	PN 16
DN 100	PN 16	PN 16

	BGN S/ H		BGN P	
ANSI 3/4" B16.5	150 lbs ¹⁾	300 lbs ¹⁾	150 lbs ²⁾	300 lbs ²⁾
ANSI 1" B16.5	150 lbs ¹⁾	300 lbs ¹⁾	150 lbs ²⁾	300 lbs ²⁾
ANSI 1 1/2" B16.5	150 lbs ¹⁾	300 lbs ¹⁾	150 lbs ²⁾	300 lbs ²⁾
ANSI 2" B16.5	150 lbs ¹⁾	300 lbs ¹⁾	150 lbs ²⁾	300 lbs ²⁾
ANSI 3" B16.5	150 lbs ¹⁾	300 lbs ¹⁾	150 lbs ²⁾	300 lbs ²⁾
ANSI 4" B16.5	150 lbs ²⁾	300 lbs ²⁾	150 lbs ²⁾	300 lbs ²⁾

1) Entire device PN 40 2) Entire device PN 16

Additional equipment: special flanges, union, food connection, welding connection

The S/H versions in special design are available up to PN 400.

8.5 Magnetic filter

The BGN flowmeter is sensitive to impure media. Before installing the device, clean the pipes of dirt, spatter and other foreign matter. If the medium comes with solid particles, connect a suitable filter in series. When dealing with flow media with ferrous particles, we recommend the connection of a magnetic filter.

To protect both magnetic filter types, MF-S (stainless steel) and MF-P/S (PTFE/stainless steel), from corrosion, encapsulated permanent magnets are laid out in spiral form. The spiral mounting produces optimum effect at small pressure loss. The filter can be supplied with groove or tongue, projection or return, other standards or special connections according to customer wishes.

Dimensions:

DN	g (mm)
15	45
25	68
40	88
50	102
65	122
80	138
100	158

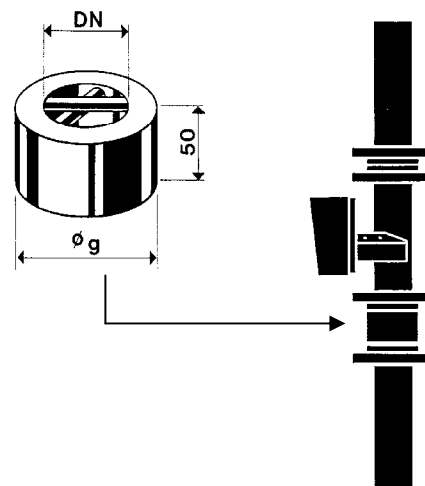

8.6 Electrical connection

Wiring

To connect the auxiliary power, remove the indicator cover, insert the connector cable into the cable gland and attach it to the terminals according to terminal diagram. Tighten the cable gland securely, remount the indicator cover and close it tightly.

8.6.1 Wiring diagram for ES transmitter (signal output 4-20 mA with HART®)

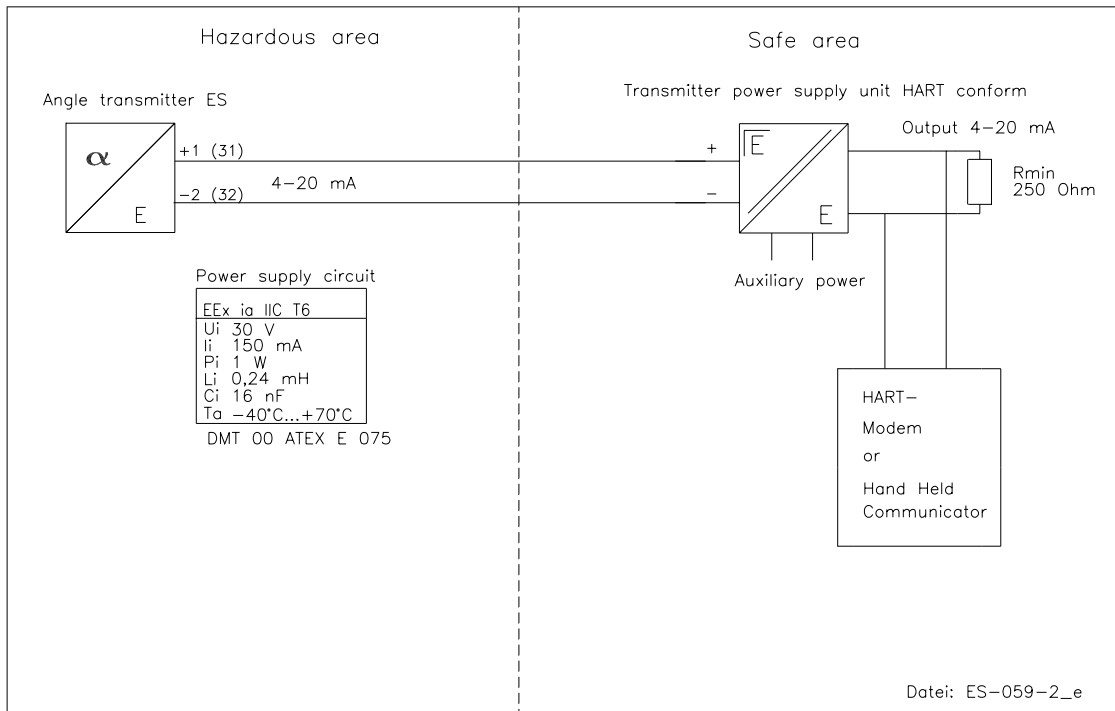

8.6.2 Wiring diagram for ES transmitter with 4-20 mA output and 2 limit transducers

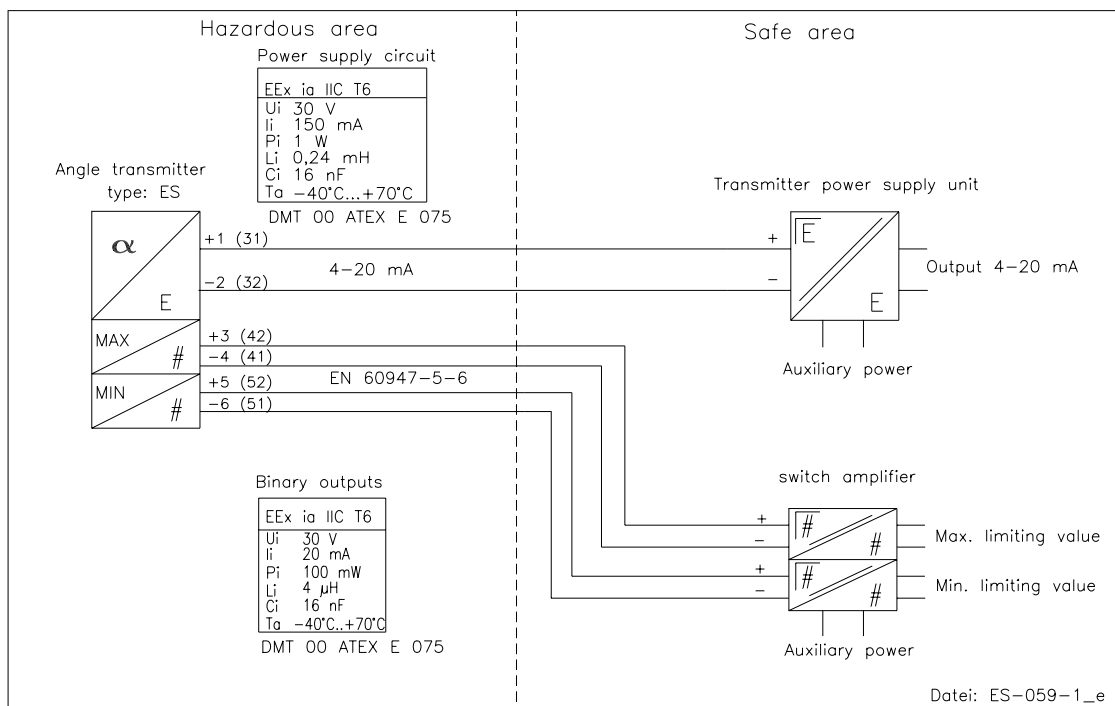

8.6.3 Wiring diagram for ES transmitter with 4- 20 mA output, pulse output and limit transducer

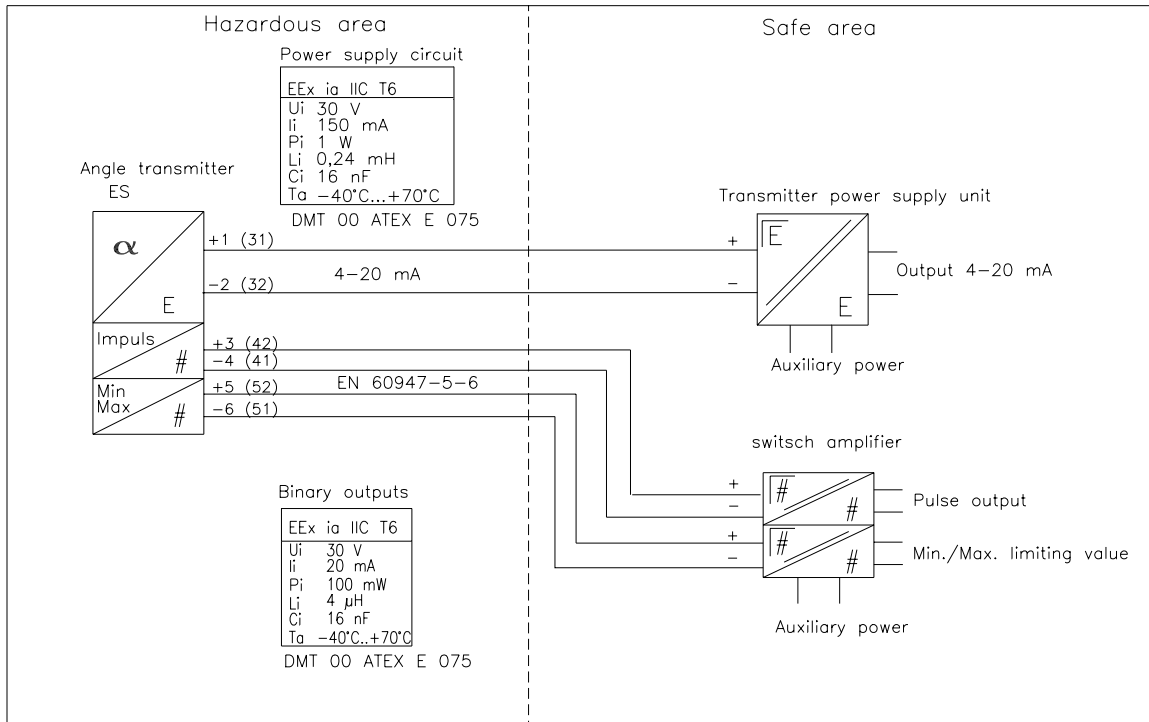

8.6.4 Wiring diagram for inductive limit transducers

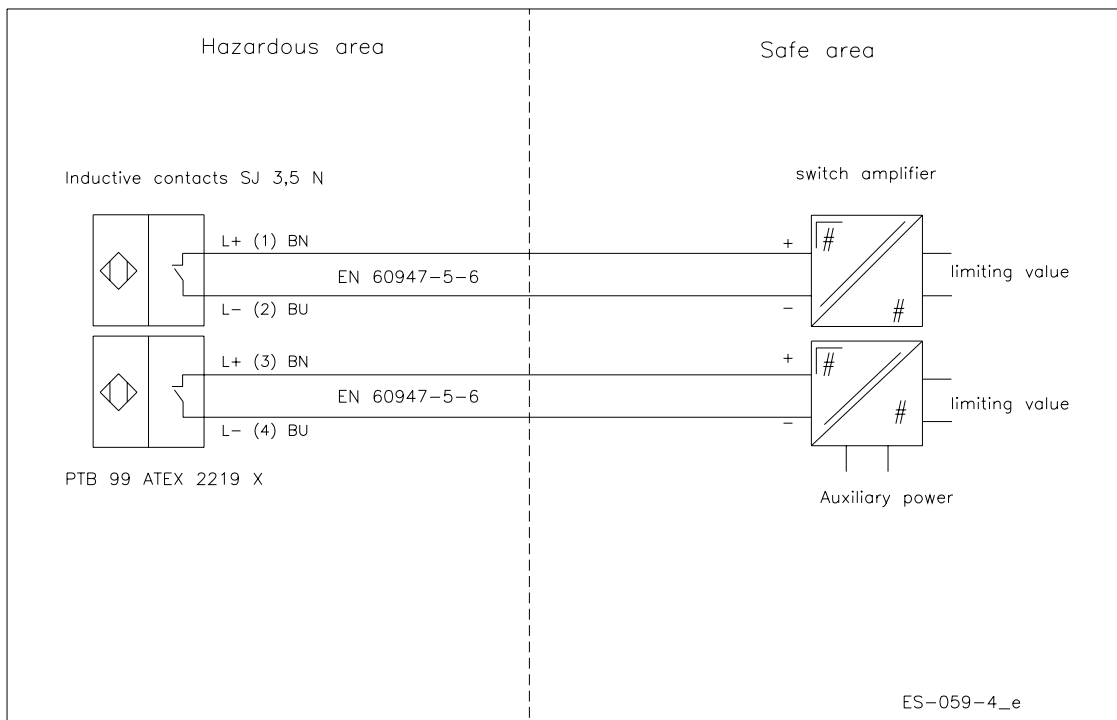

8.6.5 Wiring diagram for KINAX 3W2 transmitter with 4-20 mA output, 2 wires

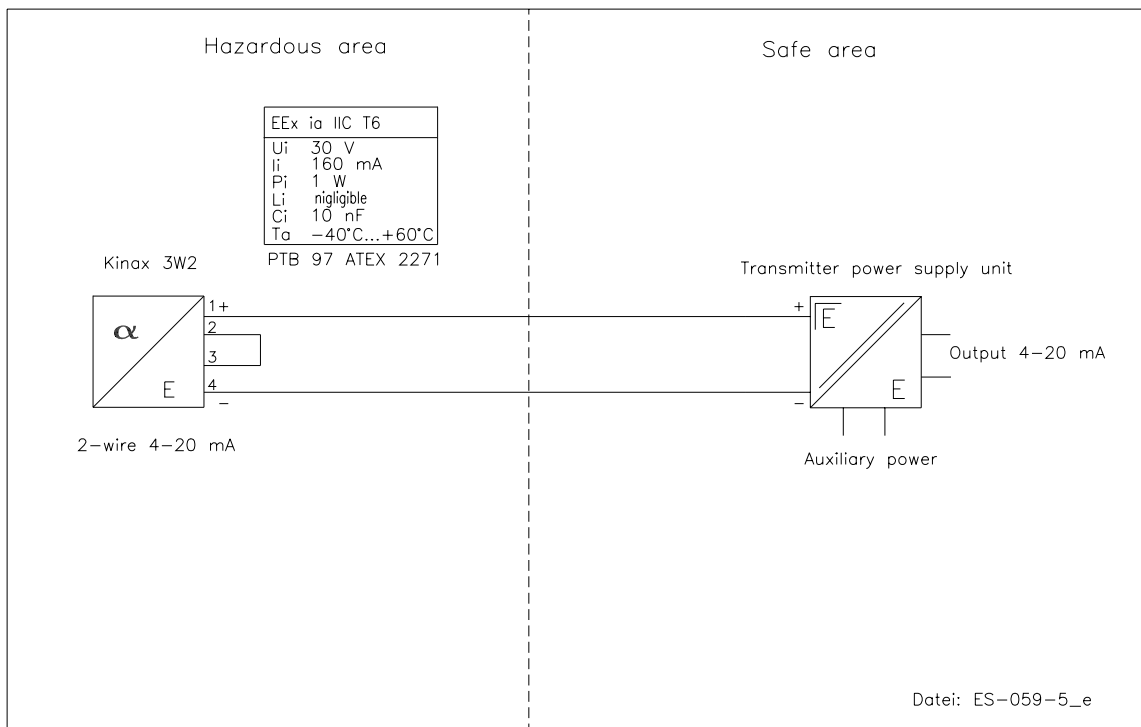

8.6.6 Wiring diagram for KINAX 3W2 transmitter with 4-20 mA output, 3 wires

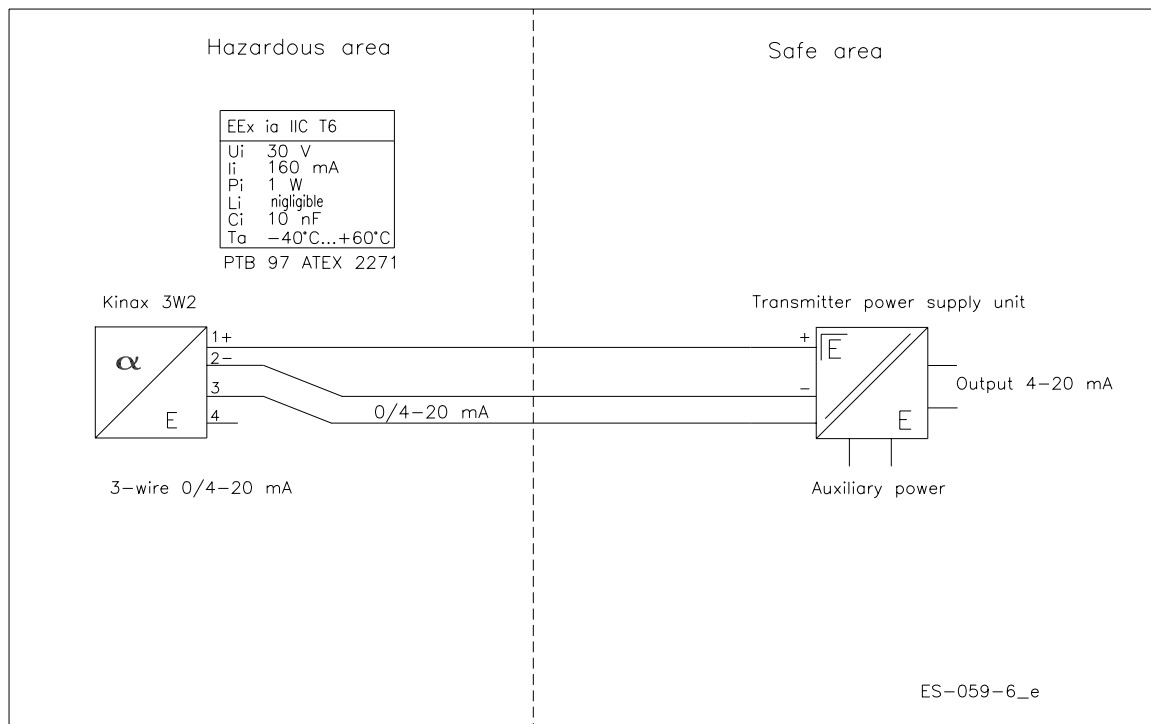

8.6.7 Wiring diagram for KINAX 3W2 transmitter with 4-20 mA output, 4 wires

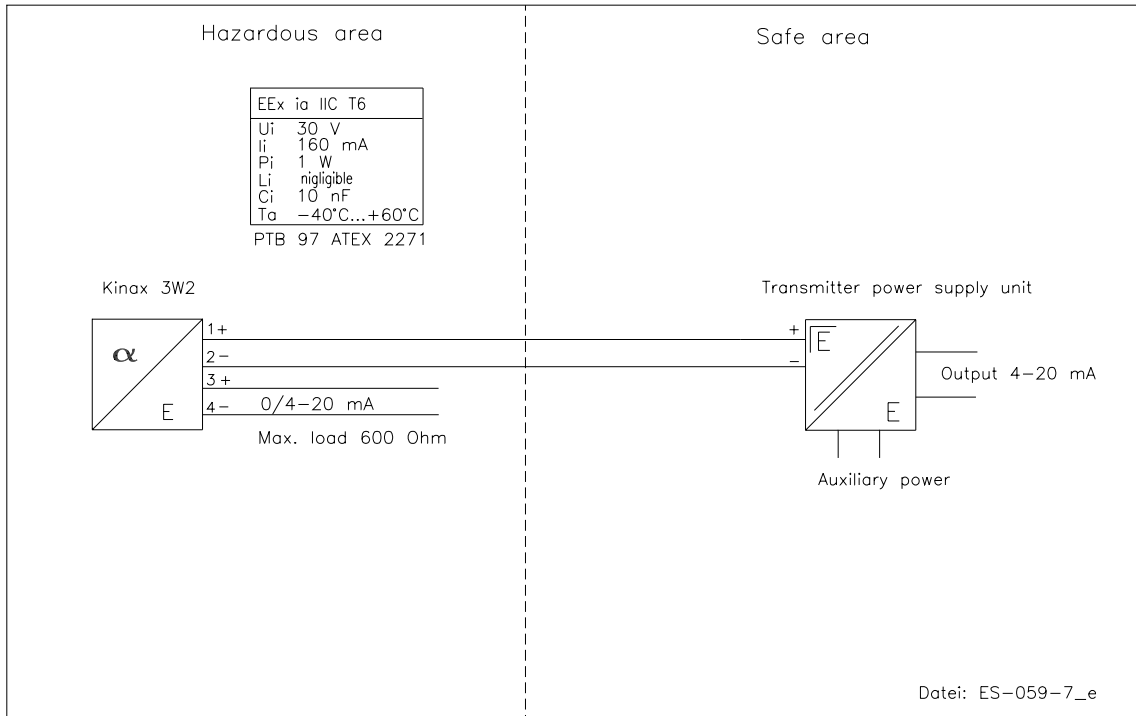

8.6.8 Wiring diagram for KEM 1 and KEM 2 double-throw microswitches

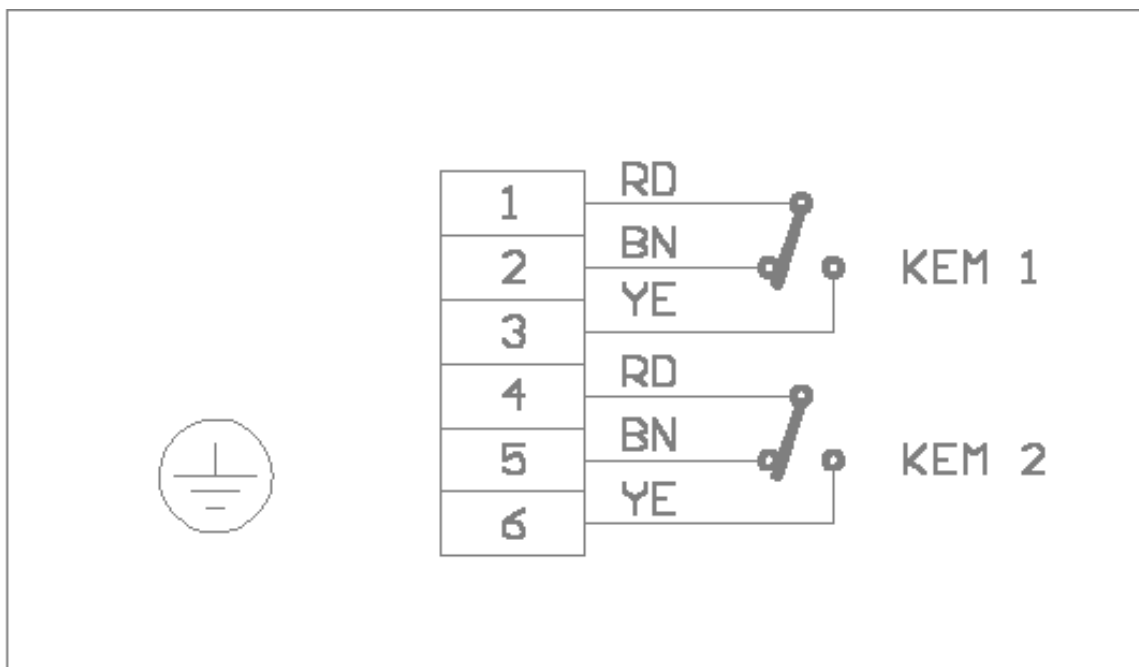

9 Indicator unit

- Analog indicator approx. 90° with pointer
- Customized product scale
- ES transmitter with freely programmable user interface
- Parameters may be changed based on the ES Operating Instructions.

10 Auxiliary power

see Electrical connection

11 CE mark

The measuring system meets the statutory requirements of the following EU directives: Directive 94/9/EC (Equipment and Protective Systems for Use in Potentially Explosive Atmospheres), the Electromagnetic Compatibility (EMC) Directive 89/336/EEC and the Pressure Equipment Directive 97/23/EC.

Measuring sensors with a connection nominal size equal to or smaller than or DN 25 fall within the scope of application of Article 3, section 3, of the Pressure Equipment Directive and need no CE mark in accordance with this directive.

Kobold Messring confirms compliance with the directives by attaching the CE mark.

12 Order information

Please include the following information in your order: Product data, specific weight, temperature, pressure, viscosity, material design, connection size, measuring range, desired accessories, required approvals and material certificates. **See Device selection by model code.**

12.1 Available accessories

- Stainless steel indicator unit, glass window IP 66
- Indicator unit for high or low temperatures pulled forward by 100 mm
- Fitting with heating or cooling jacket (with Ermeto or flange connection)
- Float system with viscous damping
- Float system with gas damping
- Float system with spring stop
- 1 or 2 inductive limit transducers
- KINAX or ES electric transmitter
- Drainable fitting (pump has been disconnected)
- Magnetic filter

13 Standards and directives, certificates and approvals

- Certified to DIN-EN 9001
- Production in accordance with AD guidelines and HPO approval (TRB200/TRD201)
- TÜV approval for welding requirements in accordance with DIN-EN 729-2
- Measuring range rated and converted to other products according to VDE/VDI guidelines 3513
- Directive 94/9/EC (Equipment and Protective Systems for Use in Potentially Explosive Atmospheres)
- EN 50014:1997+A1-A2 - General requirements
- EN 50020:1994 - Intrinsic safety "i"
- Directive 89/336/EEC (EMC Directive)
- EN 61000-6-2:1999 – Immunity industrial environment
- EN 50 081-1 – Emitted interference residential environment
- EN 55011:1998+A1:1999 – Group 1, Class B
- NAMUR recommendation NE 21
- EN 60529 – Degrees of protection through housing (IP code)

- EN 61010 – Safety requirements for electrical measuring, control and laboratory devices
- EN 60947-5-6:2000 – Switchgear and controlgear
- Directive 97/23/EC (Pressure Equipment Directive)

14 Safety instructions

14.1 Intended use

The BGN variable-area flowmeter may be used only for flow measurements of fluid and gaseous media. The manufacturer shall not be liable for damages that may result from unintended or inappropriate use.

When dealing with an aggressive medium, clarify the material durability of all wetted parts.

When using the device in hazardous areas, follow the applicable national installation rules.

14.2 Installation, start-up and operating personnel

Only trained specialists authorized by the system operator may carry out the installation, electrical installations, start-up, maintenance and operation. They must read and understand the operating manual and follow its instructions.

The required mounting, electrical installation, start-up and maintenance work may only be carried out by expert and authorized persons designated by the plant operator.

Basically, follow the conditions and provisions applicable in your country.

15 Packaging, mounting and shipment

Carefully unpack the device to avoid damaging it. The float is secured against damage in transit depending on the device size. Remove this transport protection from the fitting. By pressing the float from the bottom upwards (using a wooden stick, for example), check whether the float can easily be moved upwards and slides back downwards. The pointer position of the indicator unit must follow the direction of movement of the float.

With the help of the delivery note enclosed in the packaging, check whether all technically relevant data coincide with your requirements.

Storage and installation must be done in a clean and dry room so that contamination – especially of the interior of the fitting – is avoided. Follow the limit values for ambient temperature. When transporting the device to a remote mounting location, we recommend that you reuse the factory-issued packaging and the transport protection.

16 Maintenance

The device requires no maintenance if used according to its intended purpose. However, if cleaning is necessary to remove dirt from the measuring ring or the float, take note of the following aspects:

- Please take note that, with devices with built-in electrical equipment, removing the indicator cover restricts the EMC protection.
- Before removing a device, make sure that the pipeline is free from the product, is pressureless and has cooled down.
- Fittings with the insides coated may be carefully cleaned after removal with a brush and the appropriate cleansing agent. Carefully clean the float from possible coating. Attention: do not use the measuring ring/cone

- and float with hard objects (see Removing/installing the cone/float).
- The switching points of the limit transducers are adjustable. To do this, remove the indicator cover, unfasten the contact point indicator located on the scale and readjust it. After the adjustment, reattach the bolts of the contact point indicator. Reinstall and tighten the indicator cover.
- The calibration of the KINAX signal output is firmly set and not adjustable. Do not adjust the potentiometer of the transmitter.
- The parameterization of the ES is possible and is done via HART®. Please refer to the separate Operating Instructions for the ES.
- The gas and viscous damping cylinders can be checked for dirt (see Installing/removing the damping sets).

17 Installing and removing cone, float, damping sets/spring stop

To remove the float (cone/float), detach the device from the pipe. Then clamp the device horizontally in a vise, making sure that fitting is not damaged.

Device with measuring ring: By using a suitable tool on the guide star secure the float from contortion from above in the fitting, and remove the lower guide star's retaining screw identifiable from below in the fitting and the guide star. The float can then be taken out from above.

Device with cone: Unscrew the cone with the float using a suitable tool through the lower cone thread, and take out the float after removing the top cone stabilizer.

Important! Avoid damaging the float/measuring ring and cone. To change the measuring range, the float can be replaced once the measured variable reaches 5-50 l/h of water. In S-type devices the cone and float can be replaced at up to 40 l/h water.

The gas and viscous damping cylinders as well as the spring stop for the float can be removed from the top after the device has been removed. Proceed in reverse order when reinstalling these parts.

18 Trouble shooting

- **Indicator window clouds over:** Water in the indicator unit.
- **Indicator cover is not tight enough:** Adjust the cover seal, tighten the cover.
- **Window is opaque:** Corrosive atmosphere, ventilate.
- **Window ices over due to cold and damp atmosphere:** The device can be equipped at the factory with an air/nitrogen flush.
- **Window ices over due to very cold medium and damp atmosphere:** The device can be equipped at the factory with a pulled-forward indicator unit.
- **Device shows incorrect values:** Compare process data, density, viscosity, temperature and pressure with the values on the scale. If they deviate, convert the scale values using the VDE/VDI 3513 standard; for the signal output 2 option, carry out reparameterization.
- **Pointer does not react in spite of varying flow:** The pointer may have gotten stuck; remove the cover and move the pointer; if the pointer can be moved easily, the float cannot move. If the pointer is unable to move further, send the device to the head office for servicing.
- **The float is stuck at one place due to dirt:** Disassemble the device. If necessary, dismantle and clean the float. Install a magnetic filter if there are magnetic contaminants.
- **Float is stuck at one place due to deformation of the measuring ring and float guide because the float has been pushed upwards:** Send the device to the head office for servicing, replace the fitting, equip with additional spring stop.
- **Gas/viscous damping sets have gotten stuck due to dirt:** Disassemble the device, pull the gas/viscous damping cylinder to the top and clean it. If the parts are

damaged or worn, send the device to the head office for servicing. Install precautionary features such as filters to protect against dirt.

- **Scale pointer pulsates:** Increase the supply pressure when measuring gas. Alternatively, mount an aperture plate behind the device and check whether the valve is mounted behind the device. Select the device with the smallest possible pressure loss. Adjust to the desired flow rate, run at 100 %. Select a short distance between the flowmeter and the downstream throttle point (valve). When dealing with liquids, prevent pulsation of the product by using a volume receptacle. If necessary, have Kobold Messring install a viscous damping set or a double eddy-current damping set.
- **Electrical equipment are not functioning:** Check the auxiliary power. Are suitable power supply equipment connected, have the terminals been selected correctly, has the parameterization carried out correctly?

19 Returning devices for repair and service

Note: In accordance with the applicable German waste disposal legislation, the owner/client is responsible for the disposal of special waste and hazardous materials. Consequently, all devices sent to us for repair must be free of any hazardous materials. This also applies to possible hollow spaces and fissures in the devices. If repair is necessary, confirm the above-mentioned item in writing (**please use the form in the Appendix**).

If hazardous materials remain in or on the device after it has been returned, Kobold Messring shall be authorized to remove them at the client's expense without further inquiry.

20 Replacement parts

The following parts can be ordered as replacement parts:

- 1) Indicator cover with window/gasket/screws
- 2) Scale with standard scaling
- 3) Pointer
- 4) Limit value indicator
- 5) Pointer stop
- 6) Float with guides and safety screw
- 7) Spring stop
- 8) Complete gas damping set with float
- 9) Complete viscous damping set with float
- 10) Screwed cone set with float for small measuring range up to 40 l/h
- 11) Limit value initiator

21 Exploded views

21.1 Fitting with measuring element

Name (Figures 12-15)	Part no.
BGN - Fitting	1
BGN - Fitting with Spring stop for float	2
Float	3
Float with damping piston	4
Spring stop	5
gas damping	6
gas damping with Spring stop	7

21.1.1 BGN-.... Standard version

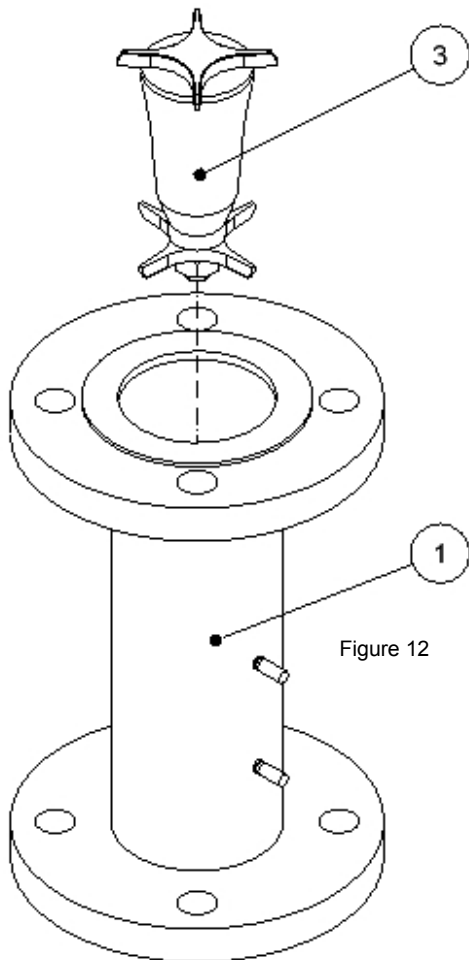

21.1.2 BGN-.... with spring stop

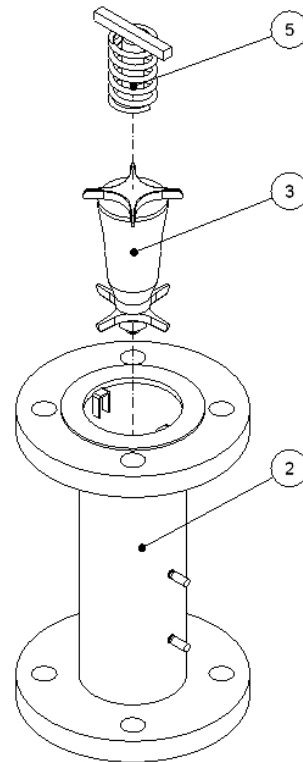

21.1.3 BGN-.... with damping piston

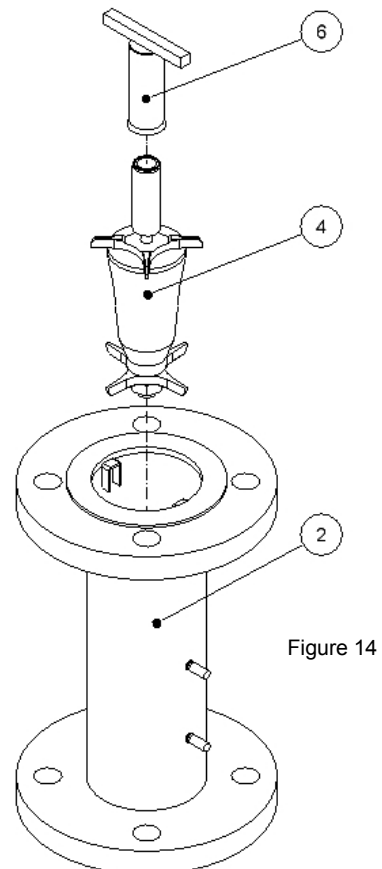

21.1.4 BGN-.... with damping piston and spring stop

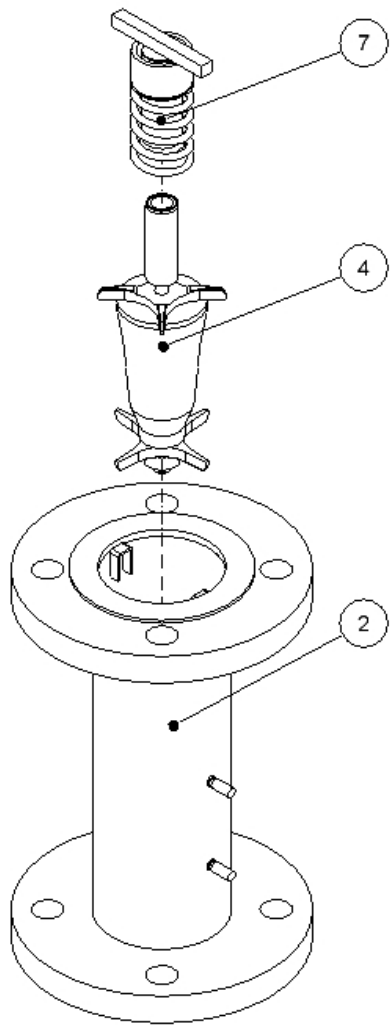

Figure 15

21.1.5 BGN-.... small measuring ranges

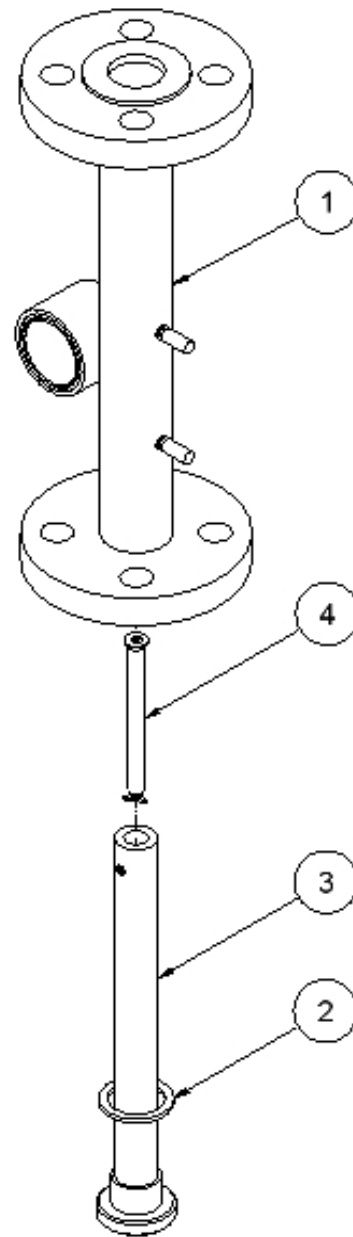

Figure 16

Name (Figures 16)	Part no.
Fitting for small measuring range	1
gasket	2
Cone with spring stop	3
Float	4

21.2 Indicator unit

Name	Part no.
Mounting plate with 1 thread M 20 x 1.5	10
Mounting plate with 2 threads M 20 x 1.5	11
Bearing unit	20
Fixing screws for bearing unit	30
Dummy plug M 20 x 1.5	40
Cable gland	41
Cable gland	42
Scale, blank	50
Scale, product scale according to original shipment (order no. necessary)	51
Screw for fixing the scale	60
Zero-point screw with nut	70
Indicator cover with glass window, gasket, screws	80
Scale pointer with hub	90
Scale pointer with hub and 2 switching dials	91
Scale pointer with hub and linearization disc	92
Scale pointer with hub and linearization disc/switching dial	93
Scale pointer with hub and 2 switching dials and ES position magnet	94
1. SJ 3,5 N limit transducer with limit value indicator	110
1. SJ 3,5 SN limit transducer with limit value indicator	111
2. SJ 3,5 N limit transducer with limit value indicator	120
2. SJ 3,5 SN limit transducer with limit value indicator	121
Connection plate for 1 limit transducer with mounting parts	130
Connection plate for 2 limit transducers with mounting parts	131
Installation set for transmitter type KINAX 3W2 Ex with lever arm and mounting parts	132
Installation set transmitter type KINAX 3W2 Ex with lever arm and mounting parts and connection for a limit transducer	133
Installation set transmitter ES Ex Hart	140
Installation set transmitter ES Ex with switch (min-max)	141
Installation set transmitter ES Ex with Profibus	142

21.2.1 Complete indicator unit, local with scale

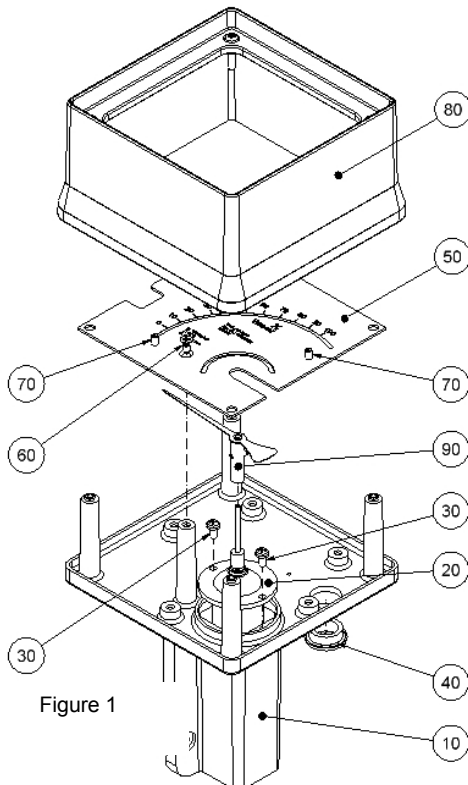

21.2.2 Complete indicator unit with 1 SJ 3,5 N limit transducer

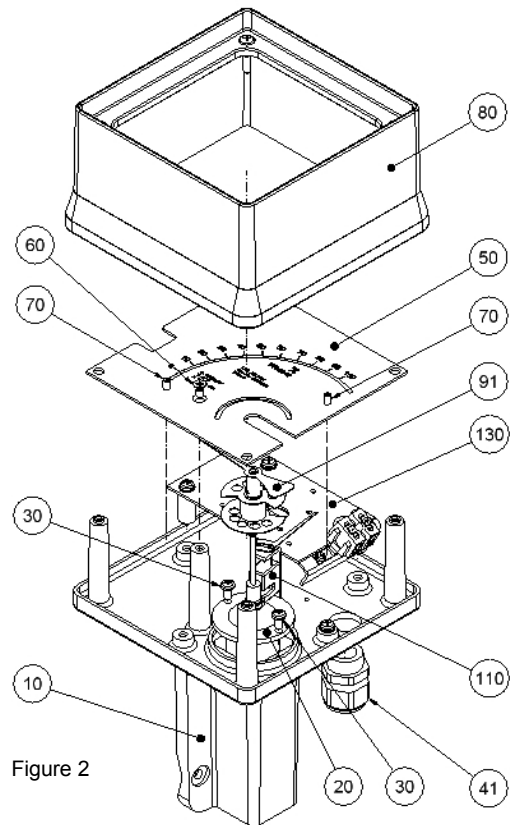

21.2.3 Complete indicator unit with 2 SJ 3,5 N limit transducers

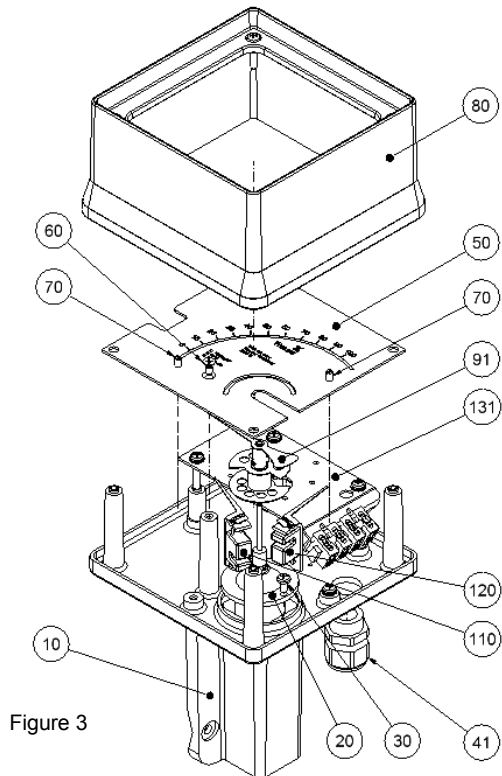

21.2.4 Complete indicator unit with E2 KINAX Ex transmitter

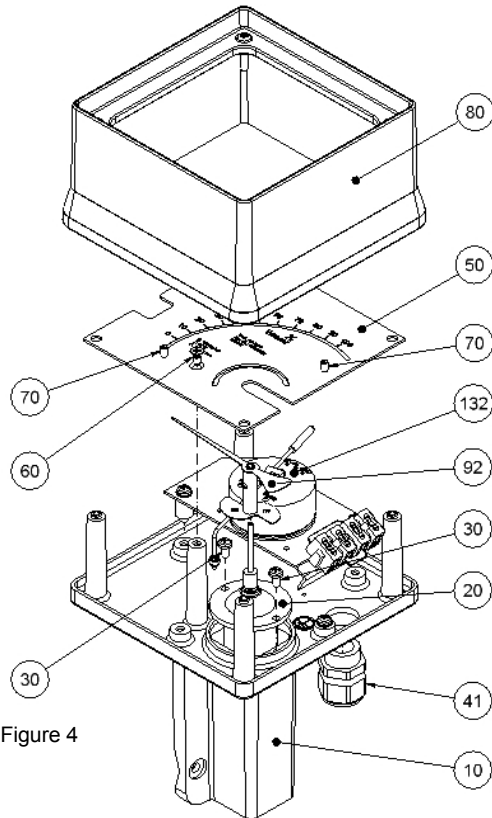

Figure 4

21.2.5 Complete indicator unit with E2 KINAX Ex transmitter and 1 SJ 3,5 N limit transducer

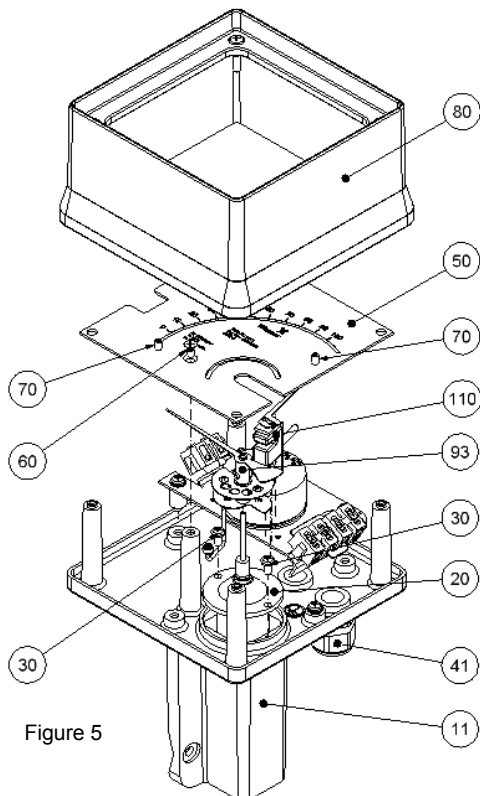

Figure 5

21.2.6 Indicator unit with transmitter type ES Ex HART®

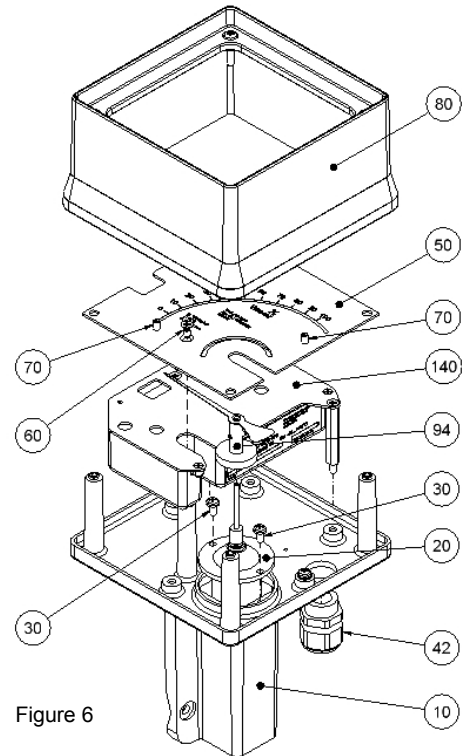

Figure 6

Name	Part no.
Mounting plate with 1 thread M 20 x 1.5	10
Mounting plate with 2 threads M 20 x 1.5	11
Bearing unit	20
Fixing screws for bearing unit	30
Dummy plug M 20 x 1.5	40
Cable gland	41
Cable gland	42
Scale, blank	50
Scale, product scale according to original shipment (order no. necessary)	51
Screw for fixing the scale	60
Zero-point screw with nut	70
Indicator cover with glass window, gasket, screws	80
Scale pointer with hub	90
Scale pointer with hub and 2 switching dials	91
Scale pointer with hub and linearization disc	92
Scale pointer with hub and linearization disc/switching dial	93
Scale pointer with hub and 2 switching dials and ES position magnet	94
1. SJ 3,5 N limit transducer with limit value indicator	110
1. SJ 3,5 SN limit transducer with limit value indicator	111
2. SJ 3,5 N limit transducer with limit value indicator	120
2. SJ 3,5 SN limit transducer with limit value indicator	121
Connection plate for 1 limit transducer with mounting parts	130
Connection plate for 2 limit transducers with mounting parts	131
Installation set for transmitter type KINAX 3W2 Ex with lever arm and mounting parts	132
Installation set transmitter type KINAX 3W2 Ex with lever arm and mounting parts and connection for a limit transducer	133
Installation set transmitter ES Ex Hart	140
Installation set transmitter ES Ex with switch (min-max)	141
Installation set transmitter ES Ex with Profibus	142

22 Decontamination certificate for device cleaning

Company:

City:

Department:

Name:

Tel:

This variable-area flowmeter

type BGN-.....

was operated using the measured medium.....

Since this measured medium is dangerous in water/poisonous/corrosive/flammable,
we have

- checked that all hollow spaces of the device are free of these materials*
- neutralized and flushed all hollow spaces of the device*

*cross out what is not applicable.





We hereby confirm that in resending the device no danger to persons or the environment is posed by the residual measured substance.

Date:

Signature:

Stamp

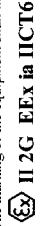
23 EC Type Examination Certificate

<div style="display: flex; justify-content: space-between; align-items: center;">  <div style="text-align: center;"> <p>Translation</p> <h2>EC-Type Examination Certificate</h2> <p>- Directive 94/9/EC - Equipment and protective systems intended for use in potentially explosive atmospheres</p> <p>DMT 00 ATEX E 075</p> <p>Electronic transmitter type ES or ES-PPA</p> <p>Manufacturer: Bopp & Reuther Heinrichs Messtechnik Josef Heinrichs GmbH & Co. Messtechnik KG</p> <p>Address: D 50933 Köln</p> </div>  </div> <p>(1) The design and construction of this equipment and any acceptable variation thereto are specified in the schedule to this type examination certificate.</p> <p>(2) The certification body of Deutsche Montan Technologie GmbH, notified body no. 0158 in accordance with Article 9 of the Directive 94/9/EC of the European Parliament and the Council of 23 March 1994, certifies that this equipment has been found to comply with the Essential Health and Safety Requirements relating to the design and construction of equipment and protective systems intended for use in potentially explosive atmospheres, given in Annex II to the Directive.</p> <p>(3) The examination and test results are recorded in the test and assessment report BVS PP 00.2071 EG.</p> <p>(4) The Essential Health and Safety Requirements are assured by compliance with:</p> <p>EN 50014:1997+A1-A2 General requirements EN 50020:1994 Intrinsic safety 'i'</p> <p>(5) If the sign "X" is placed after the certificate number, it indicates that the equipment is subject to special conditions for safe use specified in the schedule to this certificate.</p> <p>(6) This EC-Type Examination Certificate relates only to the design and construction of the specified equipment. Further requirements of Directive 94/9/EC apply to the manufacture and placing on the market of this equipment.</p> <p>(7) The marking of the equipment shall include the following: </p>	<div style="display: flex; justify-content: space-between; align-items: center;">  <div style="text-align: center;"> <p>Appendix to</p> <h2>EC-Type Examination Certificate</h2> <p>DMT 00 ATEX E 075</p> </div> </div> <p>(13) <u>15.1. Subject and type</u> Electronic transmitter type ES or ES-PPA</p> <p>(14) <u>15.2. Description</u> The electronic transmitter serves for the recording of the position or angular position of a magnet at rotameters. The completely encapsulated electronic device of the transmitter is mounted in a light alloy housing together with corresponding terminals for the connection of the intrinsically safe circuits. The transmitter is provided to be installed in a housing with a min. degree of protection IP 20.</p> <p>(15) <u>15.3. Parameters</u></p> <table border="1" style="width: 100%; border-collapse: collapse;"> <thead> <tr> <th colspan="2">15.3.1 type ES</th> </tr> </thead> <tbody> <tr> <td>15.3.1.1 Input circuit (terminals 1 and 2)</td> <td></td> </tr> <tr> <td> voltage</td> <td>Ui DC 30 V</td> </tr> <tr> <td> current</td> <td>Ii 150 mA</td> </tr> <tr> <td> power</td> <td>Pi 1 W</td> </tr> <tr> <td> effective internal inductance</td> <td>Li 0,24 mH</td> </tr> <tr> <td> effective internal capacitance</td> <td>Ci 16 nF</td> </tr> <tr> <td colspan="2">15.3.1.2 Binary outputs 1 and 2; potentially free optocoupler circuits (terminals 3 - 4 and 5 - 6), each</td> </tr> <tr> <td> voltage</td> <td>Uo DC 30 V</td> </tr> <tr> <td> current</td> <td>Io 20 mA</td> </tr> <tr> <td> power</td> <td>Po 100 mW</td> </tr> <tr> <td> effective internal inductance</td> <td>Lo 4 µH</td> </tr> <tr> <td> effective internal capacitance</td> <td>Co 16 nF</td> </tr> <tr> <td colspan="2">15.3.2 type ES-PPA Input circuit (terminals 7 and 8) for connection with a circuit in accordance with FISCO model (PTB report no. PTBW-53)</td> </tr> <tr> <td> voltage</td> <td>Uj DC 25 V</td> </tr> <tr> <td> current</td> <td>Ij 280 mA</td> </tr> <tr> <td> power</td> <td>Pj 2 W</td> </tr> <tr> <td> effective internal inductance</td> <td>Lj negligible</td> </tr> <tr> <td> effective internal capacitance</td> <td>Cj negligible</td> </tr> <tr> <td>15.3.3 ambient temperature range</td> <td>Ta -40 °C up to +70 °C</td> </tr> </tbody> </table>	15.3.1 type ES		15.3.1.1 Input circuit (terminals 1 and 2)		voltage	Ui DC 30 V	current	Ii 150 mA	power	Pi 1 W	effective internal inductance	Li 0,24 mH	effective internal capacitance	Ci 16 nF	15.3.1.2 Binary outputs 1 and 2; potentially free optocoupler circuits (terminals 3 - 4 and 5 - 6), each		voltage	Uo DC 30 V	current	Io 20 mA	power	Po 100 mW	effective internal inductance	Lo 4 µH	effective internal capacitance	Co 16 nF	15.3.2 type ES-PPA Input circuit (terminals 7 and 8) for connection with a circuit in accordance with FISCO model (PTB report no. PTBW-53)		voltage	Uj DC 25 V	current	Ij 280 mA	power	Pj 2 W	effective internal inductance	Lj negligible	effective internal capacitance	Cj negligible	15.3.3 ambient temperature range	Ta -40 °C up to +70 °C
15.3.1 type ES																																									
15.3.1.1 Input circuit (terminals 1 and 2)																																									
voltage	Ui DC 30 V																																								
current	Ii 150 mA																																								
power	Pi 1 W																																								
effective internal inductance	Li 0,24 mH																																								
effective internal capacitance	Ci 16 nF																																								
15.3.1.2 Binary outputs 1 and 2; potentially free optocoupler circuits (terminals 3 - 4 and 5 - 6), each																																									
voltage	Uo DC 30 V																																								
current	Io 20 mA																																								
power	Po 100 mW																																								
effective internal inductance	Lo 4 µH																																								
effective internal capacitance	Co 16 nF																																								
15.3.2 type ES-PPA Input circuit (terminals 7 and 8) for connection with a circuit in accordance with FISCO model (PTB report no. PTBW-53)																																									
voltage	Uj DC 25 V																																								
current	Ij 280 mA																																								
power	Pj 2 W																																								
effective internal inductance	Lj negligible																																								
effective internal capacitance	Cj negligible																																								
15.3.3 ambient temperature range	Ta -40 °C up to +70 °C																																								

page 5 of 3 in DMT 00 ATEX E 075
This certificate may only be reproduced in its entirety and without change
Am Technologiepark 1, 45307 Essen, Telefon (0203) 72-1416, Telefax (0203) 72-1716

page 1 of 3 in DMT 00 ATEX E 075
This certificate may only be reproduced in its entirety and without change
Am Technologiepark 1, 45307 Essen, Telefon (0203) 72-1416, Telefax (0203) 72-1716



Physikalisch-Technische Bundesanstalt
Braunschweig und Berlin



(1) **EC-TYPE-EXAMINATION CERTIFICATE**
(Translation)



(2) Equipment and Protective Systems Intended for Use in Potentially Explosive Atmospheres - Directive 94/9/EC
(3) EC-type-examination Certificate Number:

PTB 97 ATEX 2271

(4) Equipment: Transmitter for angular position KINAX 3W2 type 708-...
... resp. KINAX WT707 type 707-...
... resp. KINAX WT706 type 706-...

(5) Manufacturer: Camille Bauer AG
(6) Address: Aargauerstrasse 7, CH-5610 Wohlen

(7) This equipment and any acceptable variation thereto are specified in the schedule to this certificate and the documents therein referred to.

(8) The Physikalisch-Technische Bundesanstalt, notified body No. 0102 in accordance with Article 9 of the Council Directive 94/9/EC of 23 March 1994, certifies that this equipment has been found to comply with the Essential Health and Safety Requirements relating to the design and construction of equipment and protective systems intended for use in potentially explosive atmospheres, given in Annex II to the Directive.

(9) The examination and test results are recorded in the confidential report PTB Ex. 97-27381.

(10) Compliance with the Essential Health and Safety Requirements has been assured by compliance with:
EN 50014:1997
EN 50020:1994

(11) If the sign "X" is placed after the certificate number, it indicates that the equipment is subject to special conditions for safe use specified in the schedule to this certificate.

(12) This EC-type-examination Certificate relates only to the design and construction of the specified equipment in accordance with Directive 94/9/EC. Further requirements of this Directive apply to the manufacture and supply of this equipment.

The marking of the equipment shall include the following:

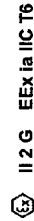

Zertifizierungsstelle Explosionsschutz
By order

Braunschweig, 21.01.1998



Dr.-Ing. U. Johannsmeyer
Regierungsdirektor

Sheet 1/3

EC-type-examination Certificates without signature and official stamp shall not be valid. The certificates may be circulated only without alteration. Extracts or alterations are subject to approval by the Physikalisch-Technische Bundesanstalt. In case of dispute, the German text shall prevail.

Physikalisch-Technische Bundesanstalt • Bundesallee 100 • D-38116 Braunschweig



(16) Test and assessment report
BVS PP 00.2071 EG as of 31. Oktober 2000

(17) Special conditions for safe use
None

We confirm the correctness of the translation from the German original.
In the case of arbitration only the German wording shall be valid and binding.

45307 Essen, dated 31.10.2000
BVS-Schul/Kn. A. 2.0000463

Deutsche Montan Technologie GmbH

[Signature]
DMT-Certification body

[Signature]

Head of special services unit

Page 3 of 3 to DMT 00 ATEX 075
This certificate may only be reproduced in its entirety and without change
Am Technologiepark 1, 45307 Essen, Telefon (020) 172-1416, Telefax (020) 172-1716

SCHEDULE

(14) EC-TYPE-EXAMINATION CERTIFICATE No. PTB 97 ATEX 2271

(15) Description of equipment

The angular position transmitter KINAX 3W2 of type 708-..., KINAX WT 707 of type WT 707-... and KINAX WT 706 of type WT 706-... convert the angular position of a shaft contactlessly to a proportional electrical output signal.

A variation of the shaft position effects a variation of a capacitance, which is converted to a proportional current alteration by the downstream electronics.

The ranges of the ambient temperature dependent on the temperature class are shown in the following table.

Minimum ambient temperature	Maximum ambient temperature	Temperature class
-40 °C	60 °C	T 6
-40 °C	75 °C	T 5

Electrical data

Supply- and measuring outputtype of protection Intrinsic Safety EEx ia IIC for connection to a certified intrinsically safe circuit (terminals 1, 2, 3) only.

Maximum values: $U_i = 30 \text{ V}$
 $I_i = 160 \text{ mA}$
 $P_i = 1 \text{ W}$

Effective internal capacitance: $C_i \leq 10 \text{ nF}$
 The effective internal inductance is negligibly small.

The transmitter for angular position KINAX 3W2 of type 708-... must be mounted into a housing which meets the requirement of a degree of protection IP 20 according to IEC 529.

Since the angular position transmitters KINAX WT 707 of type WT 707-... and KINAX WT 706 of type WT 706-... meet the requirements of a degree of protection IP 20 according to IEC 529 mounting of these variants into an additional housing is not necessary.

EC-type-examination Certificates without signature and official stamp shall not be valid. The certificates may be circulated only without alteration. Extracts or alterations are subject to approval by the Physikalisch-Technische Bundesanstalt. In case of dispute, the German text shall prevail.

SCHEDULE TO EC-TYPE-EXAMINATION CERTIFICATE PTB 97 ATEX 2271

(16) Report PTB Ex 97-27381

(17) Special conditions for safe use not applicable

(18) Essential health and safety requirements met by standards

Braunschweig, 21.01.1998

Zertifizierungsstelle Explosionsschutz
 By order



Dr.-Ing. U. Johannsmeyer
 Regierungsdirektor

EC-type-examination Certificates without signature and official stamp shall not be valid. The certificates may be circulated only without alteration. Extracts or alterations are subject to approval by the Physikalisch-Technische Bundesanstalt. In case of dispute, the German text shall prevail.



Physikalisch-Technische Bundesanstalt
Braunschweig und Berlin



(1) **EC-TYPE-EXAMINATION CERTIFICATE**
(Translation)



(2) Equipment and Protective Systems Intended for Use in Potentially Explosive Atmospheres - Directive 94/9/EC
(3) EC-type-examination Certificate Number:
PTB 99 ATEX 2219 X

(4) Equipment: Slot-type initiators types S.I... and SC...
(5) Manufacturer: Pepperl + Fuchs GmbH
(6) Address: D-68307 Mannheim

(7) This equipment and any acceptable variation thereto are specified in the schedule to this certificate and the documents therein referred to.

(8) The Physikalisch-Technische Bundesanstalt, notified body No. 0102 in accordance with Article 9 of the Council Directive 94/9/EC of 23 March 1994, certifies that this equipment has been found to comply with the Essential Health and Safety Requirements relating to the design and construction of equipment and protective systems intended for use in potentially explosive atmospheres, given in Annex II to the Directive.

(9) The examination and test results are recorded in the confidential report: PTB Ex 99-29175.
Compliance with the Essential Health and Safety Requirements has been assured by compliance with:
EN 50014:1997
EN 50020:1994

(10) If the sign "X" is placed after the certificate number, it indicates that the equipment is subject to special conditions for safe use specified in the schedule to this certificate.

(11) This EC-type-examination Certificate relates only to the design and construction of the specified equipment in accordance with Directive 94/9/EC. Further requirements of this Directive apply to the manufacture and supply of this equipment.

(12) The marking of the equipment shall include the following:



Zertifizierungsgesellschaft Explosionsschutz
By order: Braunschweig, December 22, 1999



Dr.-Ing. U. Johansmeyer
Regierungsdirektor

sheet 1/3

EC-type-examination Certificates without signature and official stamp shall not be valid. The certificates may be circulated only without alteration. Extracts or alterations are subject to approval by the Physikalisch-Technische Bundesanstalt. In case of dispute, the German text shall prevail.

Physikalisch-Technische Bundesanstalt • Bundesallee 100 • D-38116 Braunschweig



Physikalisch-Technische Bundesanstalt
Braunschweig und Berlin

SCHEDULE

(13) **EC-TYPE-EXAMINATION CERTIFICATE PTB 99 ATEX 2219 X**

(14) Description of equipment

The slot-type initiators of types S.I... and SC... are used to convert displacements into electrical signals.

The slot-type initiators may be operated with intrinsically safe circuits certified for categories and explosion groups [EEx ia] IIC or IIB resp. [EEx ib] IIC or IIB. The category as well as the explosion group of the intrinsically safe slot-type initiators depends on the connected supplying intrinsically safe circuit.

Electrical data

Evaluation and supply circuit: type of protection Intrinsic Safety EEx ia IIC/IIB resp. EEx ib IIC/IIB
only for connection to certified intrinsically safe circuits
Maximum values:

type 1	type 2	type 3	type 4
U _i = 16 V	U _i = 16 V	U _i = 16 V	U _i = 16 V
I _i = 25 mA	I _i = 25 mA	I _i = 52 mA	I _i = 76 mA
P _i = 34 mW	P _i = 64 mW	P _i = 169 mW	P _i = 242 mW

The assignment of the type of the connected circuit to the maximum permissible ambient temperature and the temperature class as well as the effective internal reactances for the individual types of slot-type initiators are shown in the table.

sheet 2/3

EC-type-examination Certificates without signature and official stamp shall not be valid. The certificates may be circulated only without alteration. Extracts or alterations are subject to approval by the Physikalisch-Technische Bundesanstalt. In case of dispute, the German text shall prevail.

Physikalisch-Technische Bundesanstalt • Bundesallee 100 • D-38116 Braunschweig

Physikalisch-Technische Bundesanstalt



Braunschweig und Berlin

SCHEDULE TO EC-TYPE-EXAMINATION CERTIFICATE PTB 99 ATEX 2219 X

types	C _i [nF]	L _i [μH]	type 1		type 2			type 3			type 4			
			maximum permissible ambient temperature in °C for application in temperature class											
			T6	T5	T4-T1	T6	T5	T4-T1	T6	T5	T4-T1	T6	T5	T4-T1
SC2-N0...	150	150	72	87	100	65	80	100	40	55	75	23	38	54
SC3,5-N0-Y...	150	150	72	87	100	65	80	100	40	55	75	23	38	54
SC3,5...-N0...	150	150	73	88	100	66	81	100	45	60	89	30	45	74
SJ1,8-N-Y...	30	100	73	88	100	67	82	100	45	60	78	30	45	57
SJ2,2-N...	30	100	73	88	100	67	82	100	45	60	78	30	45	57
SJ2-N...	30	100	73	88	100	67	82	100	45	60	78	30	45	57
SJ3,5...-N...	50	250	73	88	100	66	81	100	45	60	89	30	45	74
SJ3,5-H...	50	250	73	88	100	66	81	100	45	60	89	30	45	74
SJ5...-N...	50	250	73	88	100	66	81	100	45	60	89	30	45	74
SJ5-K...	50	550	72	87	100	66	81	100	42	57	82	26	41	63
SJ10-N...	50	1000	72	87	100	66	81	100	42	57	82	26	41	63
SJ15-N...	150	1200	72	87	100	66	81	100	42	57	82	26	41	63
SJ30-N...	150	1250	72	87	100	66	81	100	42	57	82	26	41	63

(16) Test report PTB Ex 99-29175

(17) Special conditions for safe use

- For the application within a temperature range of -60°C to -20 °C the slot-type initiators of types SJ... and SC... must be protected against damage due to impact by mounting into an additional housing.
- The connection facilities of the slot-type initiators of types SJ... and SC... shall be installed as such that at least a degree of protection of IP20 according to IEC-publication 60529:1989 is met.
- The assignment of the type of the connected circuit to the maximum permissible ambient temperature and the temperature class as well as the effective internal reactances for the individual types of slot-type initiators is shown in the table given under item (15) of this EC-type-examination certificate..
- Inadmissible electrostatic charge of the plastic housing of the slot-type initiators of type SJ30-N..., has to be avoided (warning label on the device).

(18) Essential health and safety requirements

Met by the standards mentioned above

Zertifizierungsstelle Explosionsschutz
By order:

Dr.-Ing. U. Johannsmeyer
Regierungsdirektor



Braunschweig, August 10, 1999

sheet 3/3

EC-type-examination Certificates without signature and official stamp shall not be valid. The certificates may be circulated only without alteration. Extracts or alterations are subject to approval by the Physikalisch-Technische Bundesanstalt. In case of dispute, the German text shall prevail.

Physikalisch-Technische Bundesanstalt • Bundesallee 100 • D-38116 Braunschweig

