

## Level Sensors

Reed Contact Chain



measuring  
•  
monitoring  
•  
analyzing

MM



ATEX 

PROFI<sup>®</sup>  
PROCESS FIELD BUS  
BUS



- Max. Measuring Length: 6000 mm (19.6 feet)
- Accuracy: 0.5% for L < 1900 mm (6.2 feet)
- Max. Pressure: 435 psi
- Max. Temperature: 265°F
- Connections:  
3/8" ... 2" NPT Thread, 1/2" ... 4" ANSI Flange
- Material: Stainless Steel, PVC, PP, or PVDF
- Connection Heads:  
Aluminum, PA, PP, ABS, or Stainless Steel
- Constant Level Indication, Regardless of Conductivity, Pressure, or Temperature
- Interface Level Measurement, Pt-100, or Temperature Switch Options (Upon Request)
- ATEX-Certificate: Ex ia, Ex d



Order from: **C A Briggs Company**

622 Mary Street; Suite 101; Warminster, PA 18974

Phone: 267-673-8117 - Fax: 267-673-8118

[Sales@cabriggs.com](mailto:Sales@cabriggs.com) - [www.cabriggs.com](http://www.cabriggs.com)

**Description**

The KOBOLD MM level sensor/transmitter is used for continuous level detection of all types of compatible liquids. It uses the proven float principle with magnetic transmission in a 3-wire potentiometer circuit. Its simple design with only one moving part, the float, makes the transmitter particularly reliable. A wide range of sensors are offered in different materials, designs, and connections, making them suitable for many measured-value data acquisition applications.

**Principle of Operation**

A magnet within the float activates various reed contacts within the guide tube. The reed switches in conjunction with a bank of resistors form a measuring chain that generates a resistance proportional to the height of the level. This sensing technique is similar to the operation of a sliding contact on a resistance potentiometer. The resistance sampled from the chain is transferred to a transmitter (option) which outputs a current signal proportional to the liquid level or, depending on the design, also allows limit values to be monitored. The transmitter can be mounted in the terminal box or as an external instrument. Local analog or digital indication can also be provided.

**Applications**

- Waste Water and Purification Plants
- Feed and Batching Tanks
- Chemical Tanks
- Manufacturing Industry
- Power Plants
- Pharmaceutical Industry
- Beverage and Food Industry

**ATEX-Certificate:**

- II 1 G Ex ia IIC T6 Ga (LOM 06ATEX2054X (supplement no. 3))  
 -20≤Ta≤+60°C
- II 1/2G Ex d II C T6 Ga/Gb (LOM 14ATEX2075 X)  
 1/2D Ex tb IIIC T85°C Da/Db

Possible options available (in case of electrical cable connection):

- PT100 (3-wire, category B)
- Temperature switch (N/C contact) at 150°F, 175°F or 220°F (other switching outputs on request)
- Interface level measurement at density difference 150 g/l

**Sensor Design**

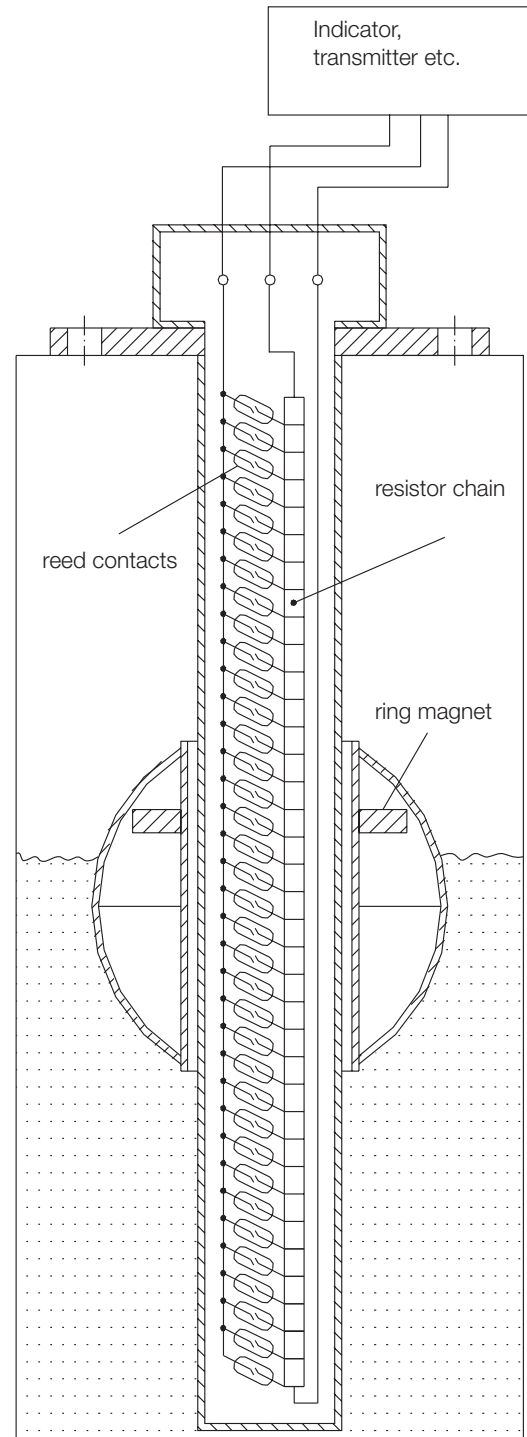

**Float Designs**

Type	Form	Materials	Float Outside Ø (mm)	Height (mm)	Bore Hole Ø (mm)	Min. Liquid Specific Gravity	Temperature Range	Nominal Pressure at 70°F
M05	Cylinder Hollow	PP	42	40	14	>0.6	14 ...175°F	40 psi
M07	Cylinder Hollow	PVC-U	42	40	14	>0.9	32 ...140°F	40 psi
M08	Cylinder Hollow	316 SS	38	52	15	>0.55	-4 ...265°F	290 psi
M10	Ball Hollow	316 SS	52	52	15	>0.6	-4 ...265°F	435 psi
M13	Cylinder Hollow	PVDF	38	60	18	>0.6	14 ...250°F	30 psi
M15	Cylinder Hollow	PP	60	60	18	>0.4	14 ...175°F	85 psi
M16	Cylinder Hollow	PVC-U	60	60	18	>0.6	32 ...140°F	40 psi
M20	Ball Hollow	316L SS	95	95	20.8	>0.5	-4 ...265°F	215 psi



Order from: **C A Briggs Company**

622 Mary Street; Suite 101; Warminster, PA 18974

Phone: 267-673-8117 - Fax: 267-673-8118

[Sales@cabriggs.com](mailto:Sales@cabriggs.com) - [www.cabriggs.com](http://www.cabriggs.com)

No responsibility taken for errors; subject to change without prior notice.

**PP Design: Model MM-M05..**

**Technical Details**

**Min. Length of Guide Tube:** 300 mm (1 foot)  
**Max. Length of Guide Tube:** 2000 mm (6.5 feet)  
**Guide Tube and Screwed Fitting:** Polypropylene  
**Min. Liquid Density:** >0.6 kg/dm<sup>3</sup>  
**Max. Pressure (at 70 °F):** 40 psi  
**Temperature Range:** 14 ... 175 °F  
**Max. Temperature PVC Cable:** 158 °F  
**Max. Temp. Silicone Cable:** 175 °F  
**Max. Resistance of Meas. Chain:** 36 Ω each 10 mm, total length <1900 mm (6.2 feet)  
 10 Ω each 10 mm, total length ≥1900 mm (6.2 feet)  
**Installation Position:** Vertical ±30°  
**Cable Length:** 1000 mm (3.3 feet)  
**Protection:** IP 65  
**Connection Heads:** See following pages

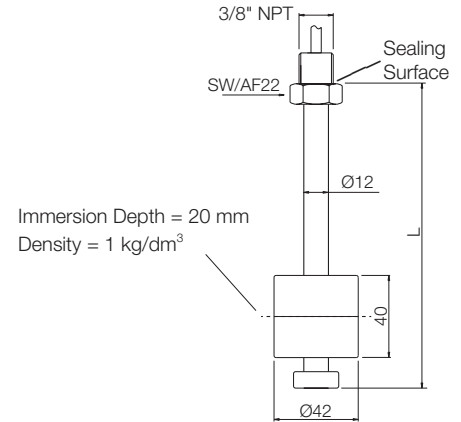

Model	Type	Process Connection	Output	ATEX
MM-	..M05..	..N10.. = 3/8" NPT ..XXX.. = See Pages 8 - 11	..P.. = Resistance Output 1 m PVC ..S.. = Resistance Output 1 m Silicone ..Y <sup>1)</sup> .. = Resistance Output, Special Cable ..2.. = Resistance Output, No Cable ..M.. = Transmitter 4 - 20 mA 2-wire (5333D) ..H.. = Transmitter 4 - 20 mA HART® (5337) <sup>2)</sup> ..F.. = Transmitter Profibus®/Fieldbus® (5350) <sup>3)</sup>	..0 = without ..E = Ex ia

**Note:** Please clearly specify the length »L«.

<sup>1)</sup> Please specify in writing length and type of cable  
<sup>2)</sup> 5337A for approval option "0", 5337D (ATEX) for approval option "E"  
<sup>3)</sup> 5350A for approval option "0", 5350B (ATEX) for approval option "E"

**PP Design for Low Densities: Model MM-M15..**

**Technical Details**

**Min. Length of Guide Tube:** 300 mm (1foot)  
**Max. Length of Guide Tube:** 5000 mm (16.4 feet)  
**Guide Tube and Screwed Fitting:** PP  
**Min. Liquid Density:** >0.4 kg/dm<sup>3</sup>  
**Max. Pressure (at 70 °F):** 85 psi  
**Temperature Range:** 14... 175 °F  
**Max. Temperature PVC Cable:** 158 °F  
**Max. Temp. Silicone Cable:** 175 °F  
**Max. Resistance of Meas. Chain:** 36 Ω for each 10 mm, when total length <1900 mm  
 10 Ω for each 10 mm, when total length ≥1900 mm  
**Installation Position:** Vertical ±30°  
**Cable Length:** 1000 mm (3.3 feet)  
**Protection:** IP 65  
**Connection Heads:** See following pages

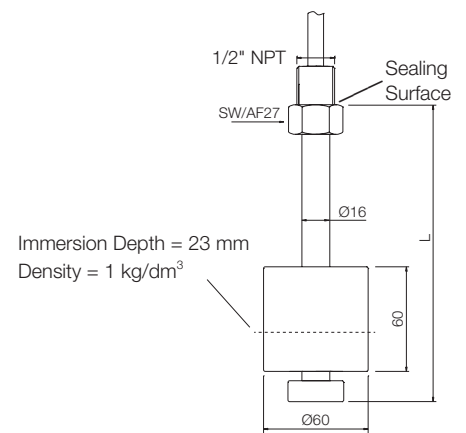

Model	Type	Process Connection	Output	ATEX
MM-	..M15..	..N15.. = 1/2" NPT ..XXX.. = See Pages 8 - 11	..P.. = Resistance Output 1 m PVC ..S.. = Resistance Output 1 m Silicone ..Y <sup>1)</sup> .. = Resistance Output, Special Cable ..2.. = Resistance Output, No Cable ..M.. = Transmitter 4 - 20 mA 2-wire (5333D) ..H.. = Transmitter 4 - 20 mA HART® (5337) <sup>2)</sup> ..F.. = Transmitter Profibus®/Fieldbus® (5350) <sup>3)</sup>	..0 = without ..E = Ex ia

**Note:** Please clearly specify the length »L«.

<sup>1)</sup> Please specify in writing length and type of cable  
<sup>2)</sup> 5337A for approval option "0", 5337D (ATEX) for approval option "E"  
<sup>3)</sup> 5350A for approval option "0", 5350B (ATEX) for approval option "E"



**PVC-U Design: Model MM-M07..**

**Technical Details**

<b>Min. Length of Guide Tube:</b>	300 mm (1 foot)
<b>Max. Length of Guide Tube:</b>	2000 mm (6.5 feet)
<b>Guide Tube and Screwed Fitting:</b>	PVC-U
<b>Min. Liquid Density:</b>	>0.9 kg/dm <sup>3</sup>
<b>Max. Pressure (at 70°F):</b>	40 psi
<b>Temperature Range:</b>	32...140°F
<b>Max. Temperature PVC Cable:</b>	140°F
<b>Max. Temp. Silicone Cable:</b>	140°F
<b>Max. Resistance of Meas. Chain:</b>	36 Ω for each 10 mm, when total length <1900 mm 10 Ω for each 10 mm, when total length ≥1900 mm
<b>Installation Position:</b>	Vertical ±30°
<b>Cable Length:</b>	1000 mm (3.3 feet)
<b>Protection:</b>	IP 65
<b>Connection Heads:</b>	See following pages

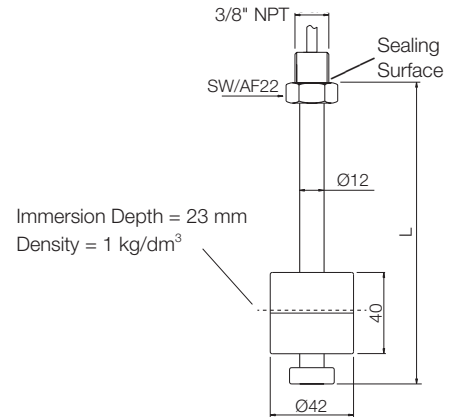

Model	Type	Process Connection	Output	ATEX
MM-	..M07..	..N10.. = 3/8" NPT ..XXX.. = See Pages 8 - 11	..P.. = Resistance Output 1 m PVC ..S.. = Resistance Output 1 m Silicone ..Y <sup>1)</sup> .. = Resistance Output, Special Cable ..2.. = Resistance Output, No Cable ..M.. = Transmitter 4-20 mA 2-wire (5333D) ..H.. = Transmitter 4-20 mA HART <sup>®</sup> (5337) <sup>2)</sup> ..F.. = Transmitter Profibus <sup>®</sup> /Fieldbus <sup>®</sup> (5350) <sup>3)</sup>	..0 = without ..E = Ex ia

**Note:** Please clearly specify the length »L«.

<sup>1)</sup> Please specify in writing length and type of cable  
<sup>2)</sup> 5337A for approval option "0", 5337D (ATEX) for approval option "E"  
<sup>3)</sup> 5350A for approval option "0", 5350B (ATEX) for approval option "E"

**PVC-U Design for Low Densities: Model MM-M16..**

**Technical Details**

<b>Min. Length of Guide Tube:</b>	300 mm (1 foot)
<b>Max. Length of Guide Tube:</b>	5000 mm (16.4 feet)
<b>Guide Tube and Screwed Fitting:</b>	PVC-U
<b>Min. Liquid Density:</b>	>0.6 kg/dm <sup>3</sup>
<b>Max. Pressure (at 70°F):</b>	40 psi
<b>Temperature Range:</b>	32...140°F
<b>Max. Temperature PVC Cable:</b>	140°F
<b>Max. Temp. Silicone Cable:</b>	140°F
<b>Max. Resistance of Meas. Chain:</b>	36 Ω for each 10 mm, when total length <1900 mm 10 Ω for each 10 mm, when total length ≥1900 mm
<b>Installation Position:</b>	Vertical ±30°
<b>Cable Length:</b>	1000 mm (3.3 feet)
<b>Protection:</b>	IP 65
<b>Connection Heads:</b>	See following pages

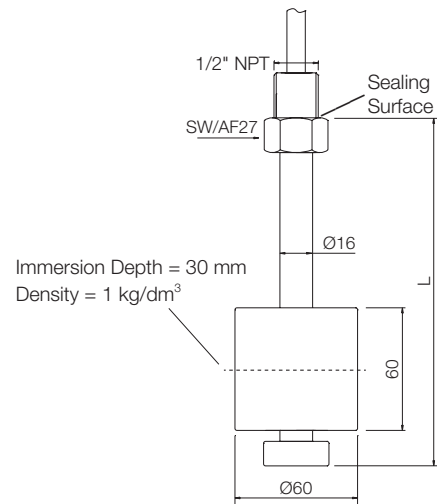

Model	Type	Process Connection	Output	ATEX
MM-	..M16..	..N15.. = 1/2" NPT ..XXX.. = See Pages 8 - 11	..P.. = Resistance Output 1 m PVC ..S.. = Resistance Output 1 m Silicone ..Y <sup>1)</sup> .. = Resistance Output, Special Cable ..2.. = Resistance Output, No Cable ..M.. = Transmitter 4-20 mA 2-wire (5333D) ..H.. = Transmitter 4-20 mA HART <sup>®</sup> (5337) <sup>2)</sup> ..F.. = Transmitter Profibus <sup>®</sup> /Fieldbus <sup>®</sup> (5350) <sup>3)</sup>	..0 = without ..E = Ex ia

**Note:** Please clearly specify the length »L«.

<sup>1)</sup> Please specify in writing length and type of cable  
<sup>2)</sup> 5337A for approval option "0", 5337D (ATEX) for approval option "E"  
<sup>3)</sup> 5350A for approval option "0", 5350B (ATEX) for approval option "E"

**PVDF Design: Model MM-M13..**

**Technical Details**

**Min. Length of Guide Tube:** 300 mm (1 foot)  
**Max. Length of Guide Tube:** 5000 mm (16.4 feet)  
**Guide Tube and Screwed Fitting:** PVDF  
**Min. Liquid Density:** >0.6 kg/dm<sup>3</sup>  
**Max. Pressure (at 70 °F):** 30 psi  
**Temperature Range:** 14...250 °F  
**Max. Temperature PVC Cable:** 158 °F  
**Max. Temp. Silicone Cable:** 250 °F  
**Max. Resistance of Meas. Chain:** 36 Ω for each 10 mm, when total length <1900 mm  
 10 Ω for each 10 mm, when total length ≥1900 mm  
**Installation Position:** Vertical ±30°  
**Cable Length:** 1000 mm (3.3 feet)  
**Protection:** IP 65  
**Connection Heads:** See following pages

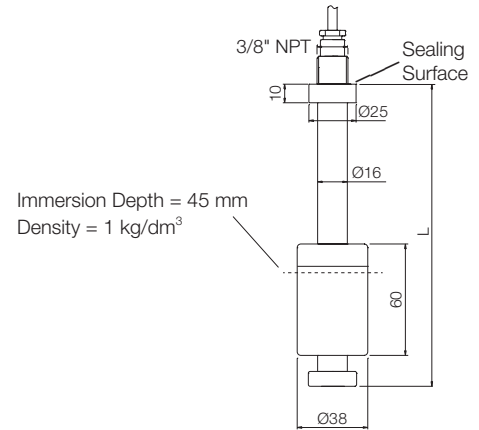

Model	Type	Process Connection	Output	ATEX
MM-	..M13..	..N10.. = 3/8" NPT ..XXX.. = See Pages 8 - 11	..P.. = Resistance Output 1 m PVC ..S.. = Resistance Output 1 m Silicone ..Y <sup>1)</sup> .. = Resistance Output, Special Cable ..2.. = Resistance Output, No Cable ..M.. = Transmitter 4 - 20 mA 2-wire (5333D) ..H.. = Transmitter 4 - 20 mA HART® (5337) <sup>2)</sup> ..F.. = Transmitter Profibus®/Fieldbus® (5350) <sup>3)</sup>	..0 = without ..E = Ex ia

*Note: Please clearly specify the length »L«.*

<sup>1)</sup> Please specify in writing length and type of cable  
<sup>2)</sup> 5337A for approval option "0", 5337D (ATEX) for approval option "E"  
<sup>3)</sup> 5350A for approval option "0", 5350B (ATEX) for approval option "E"

**316L SS Design: Model MM-M08..**

**Technical Details**

**Min. Length of Guide Tube:** 300 mm (1 foot)  
**Max. Length of Guide Tube:** 6000 mm (19.6 feet)  
**Guide Tube and Screwed Fitting:** 316L Stainless steel  
**Min. Liquid Density:** > 0.55 kg/dm<sup>3</sup>  
**Max. Pressure (at 70 °F):** 290 psi  
**Temperature Range:** -4 ... 265 °F  
**Max. Temperature PVC Cable:** 158 °F  
**Max. Temp. Silicone Cable:** 265 °F  
**Max. Resistance of Meas. Chain:** 36 Ω for each 10 mm, when total length <1900 mm  
 10 Ω for each 10 mm, when total length ≥1900 mm  
**Installation Position:** Vertical ±30°  
**Cable Length:** 1000 mm (3.3 feet)  
**Protection:** IP 65  
**Connection Heads:** See following pages

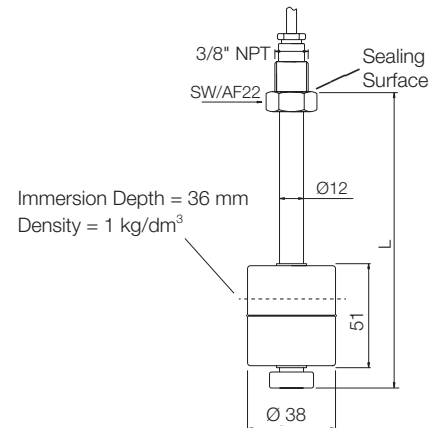

Model	Type	Process Connection	Output	ATEX
MM-	..M08..	..N10.. = 3/8" NPT ..XXX.. = See Pages 8 - 11	..P.. = Resistance Output 1 m PVC ..S.. = Resistance Output 1 m Silicone ..Y <sup>1)</sup> .. = Resistance Output, Special Cable ..2.. = Resistance Output, No Cable ..M.. = Transmitter 4 - 20 mA 2-wire (5333D) ..H.. = Transmitter 4 - 20 mA HART® (5337) <sup>2)</sup> ..F.. = Transmitter Profibus®/Fieldbus® (5350) <sup>3)</sup>	0 = without E = Ex ia F <sup>4)</sup> = Ex d

*Note: Please clearly specify the length »L«.*

<sup>1)</sup> Please specify in writing length and type of cable  
<sup>2)</sup> 5337A for approval option "0" and "F", 5337D (ATEX) for approval option "E"  
<sup>3)</sup> 5350A for approval option "0" and "F", 5350B (ATEX) for approval option "E"  
<sup>4)</sup> Only available for head models: L, C, E. In preparation



**316L SS Design for High Pressure: Model MM-M10..**

**Technical Details**

**Min. Length of Guide Tube:** 300 mm (1 foot)  
**Max. Length of Guide Tube:** 6000 mm (19.6 feet)  
**Guide Tube and Screwed Fitting:** 316L Stainless steel  
**Min. Liquid Density:** >0.6 kg/dm<sup>3</sup>  
**Max. Pressure (at 70°F):** 435 psi  
**Temperature Range:** -4...265°F  
**Max. Temperature PVC Cable:** 158°F  
**Max. Temp. Silicone Cable:** 265°F  
**Max. Resistance of Meas. Chain:** 36 Ω for each 10 mm, when total length <1900 mm  
 10 Ω for each 10 mm, when total length ≥1900 mm  
**Installation Position:** Vertical ±30°  
**Cable Length:** 1000 mm (3.3 feet)  
**Protection:** IP 65  
**Connection Heads:** See following pages

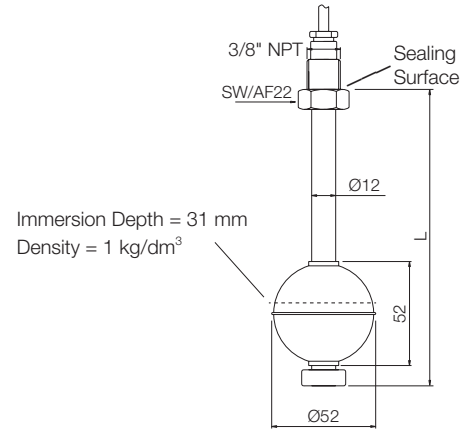

Model	Type	Process Connection	Output	ATEX
MM-	..M10..	..N10.. = 3/8" NPT ..XXX.. = See Pages 8 - 11	..P.. = Resistance Output 1 m PVC ..S.. = Resistance Output 1 m Silicone ..Y <sup>1)</sup> .. = Resistance Output, Special Cable ..2.. = Resistance Output, No Cable ..M.. = Transmitter 4 - 20 mA 2-wire (5333D) ..H.. = Transmitter 4 - 20 mA HART® (5337) <sup>2)</sup> ..F.. = Transmitter Profibus®/Fieldbus® (5350) <sup>3)</sup>	..0 = without ..E = Ex ia ..F <sup>4)</sup> = Ex d

**Note:** Please clearly specify the length »L«.

<sup>1)</sup> Please specify in writing length and type of cable  
<sup>2)</sup> 5337A for approval options "O" and "F", 5337D (ATEX) for approval option "E"  
<sup>3)</sup> 5350A for approval options "O" and "F", 5350B (ATEX) for approval option "E"  
<sup>4)</sup> Only available for head models: L, C, E. In preparation

**316L SS Design for Low Densities: Model MM-M20..**

**Technical Details**

**Min. Length of Guide Tube:** 300 mm (1 foot)  
**Max. Length of Guide Tube:** 6000 mm (19.6 feet)  
**Guide Tube and Screwed Fitting:** 316L Stainless steel  
**Min. Liquid Density:** >0.5 kg/dm<sup>3</sup>  
**Max. Pressure (at 70°F):** 215 psi  
**Temperature Range:** -4...265°F  
**Max. Temperature PVC Cable:** 158°F  
**Max. Temp. Silicone Cable:** 265°F  
**Max. Resistance of Meas. Chain:** 36 Ω for each 10 mm, when total length <1900 mm  
 10 Ω for each 10 mm, when total length ≥1900 mm  
**Installation Position:** Vertical ±30°  
**Cable Length:** 1000 mm (3.3 feet)  
**Protection:** IP 65  
**Connection Heads:** See following pages

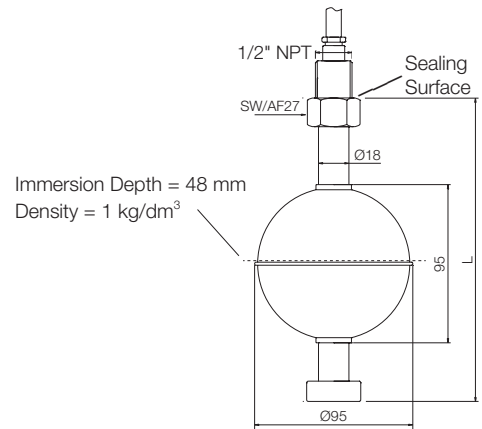

Model	Type	Process Connection	Output	ATEX
MM-	..M20..	..N15.. = 1/2" NPT ..XXX.. = See Pages 8 - 11	..P.. = Resistance Output 1 m PVC ..S.. = Resistance Output 1 m Silicone ..Y <sup>1)</sup> .. = Resistance Output, Special Cable ..2.. = Resistance Output, No Cable ..M.. = Transmitter 4 - 20 mA 2-wire (5333D) ..H.. = Transmitter 4 - 20 mA HART® (5337) <sup>2)</sup> ..F.. = Transmitter Profibus®/Fieldbus® (5350) <sup>3)</sup>	..0 = without ..E = Ex ia ..F <sup>4)</sup> = Ex d

**Note:** Please clearly specify the length »L«.

<sup>1)</sup> Please specify in writing length and type of cable  
<sup>2)</sup> 5337A for approval options "O" and "F", 5337D (ATEX) for approval option "E"  
<sup>3)</sup> 5350A for approval options "O" and "F", 5350B (ATEX) for approval option "E"  
<sup>4)</sup> Only available for head models: L, C, E. In preparation

**Model 1: Housing with PP Screw Cover**

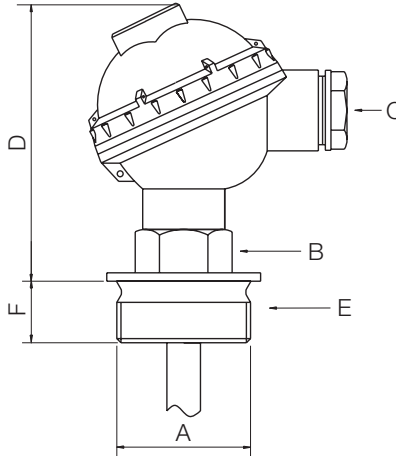

**Dimensions and Materials**

Model	Process Connection (A) <sup>1)</sup>	Width Across Flats (B)	Electrical Connection (C)	Overall Height (D)	Screwed Fitting (E)	Thread Length <sup>3)</sup> (F)	t <sub>max</sub>
1..	..N8 = 1½" NPT	30 AF	PG16	100 mm	PP	25 mm	190°F <sup>2)</sup>
	..N9 = 2" NPT	36 AF				27 mm	

<sup>1)</sup> Size of process connection must accommodate float diameter

<sup>2)</sup> Max. temperature 85°C if transmitter output is selected

<sup>3)</sup> Overall Length L includes thread length

**Model 3: Housing with PA Screw Cover**

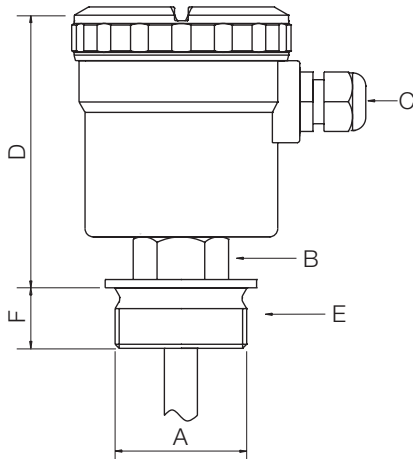

**Dimensions and Materials**

Model	Process Connection (A) <sup>1)</sup>	Width Across Flats (B)	Electrical Connection (C)	Overall Height (D)	Screwed Fitting (E)	Thread Length <sup>3)</sup> (F)	t <sub>max</sub>
3..	..N8 = 1½" NPT	30 AF	M16x1.5	104 mm	316L SS	25 mm	190°F <sup>2)</sup>
	..N9 = 2" NPT	36 AF				27 mm	

<sup>1)</sup> Size of process connection must accommodate float diameter

<sup>2)</sup> Max. temperature 85°C if transmitter output is selected

<sup>3)</sup> Overall Length L includes thread length

**Model 4: Aluminum Housing**

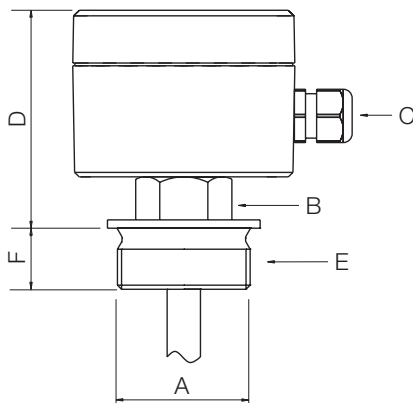

**Dimensions and Materials**

Model	Process Connection (A) <sup>1)</sup>	Width Across Flats (B)	Electrical Connection (C)	Overall Height (D)	Screwed Fitting (E)	Thread Length <sup>3)</sup> (F)	t <sub>max</sub>
4..	..N8 = 1½" NPT	30 AF	M16x1.5	73 mm	316L SS	25 mm	190°F <sup>2)</sup>
	..N9 = 2" NPT	36 AF				27 mm	

<sup>1)</sup> Size of process connection must accommodate float diameter

<sup>2)</sup> Max. temperature 85°C if transmitter output is selected

<sup>3)</sup> Overall Length L includes thread length



**Model 5: ABS Housing**

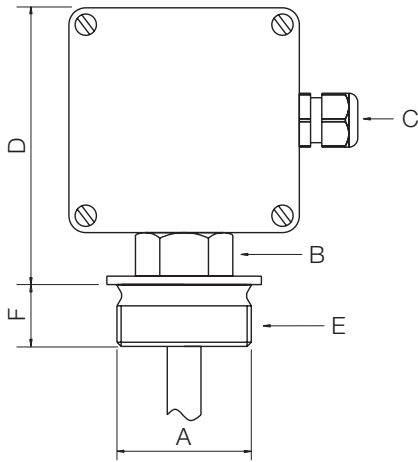

**Dimensions and Materials**

Model	Process Connection (A) <sup>1)</sup>	Width Across Flats (B)	Electrical Connection (C)	Overall Height (D)	Screwed Fitting (E)	Thread Length <sup>2)</sup> (F)	t <sub>max</sub>
5..	..N8 = 1½" NPT	30 AF	M16x1.5	100 mm	PVC	25 mm	140°F
	..N9 = 2" NPT	36 AF				27 mm	

<sup>1)</sup> Size of process connection must accommodate float diameter

<sup>2)</sup> Overall Length L includes thread length

**Model 6: Housing with PA Screw Cover**

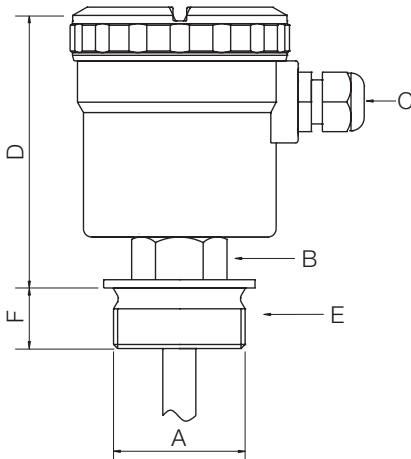

**Dimensions and Materials**

Model	Process Connection (A) <sup>1)</sup>	Width Across Flats (B)	Electrical Connection (C)	Overall Height (D)	Screwed Fitting (E)	Thread Length <sup>3)</sup> (F)	t <sub>max</sub>
6..	..N8 = 1½" NPT	30 AF	M16x1.5	104 mm	PVDF	25 mm	190 °F <sup>2)</sup>

<sup>1)</sup> Size of process connection must accommodate float diameter

<sup>2)</sup> Max. temperature 85°C if transmitter output is selected

<sup>3)</sup> Overall Length L includes thread length

**Model 7: Connector with Connecting Box**

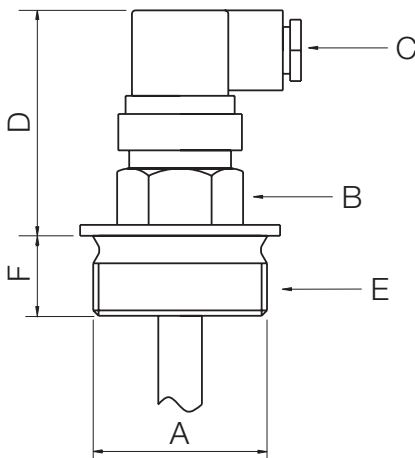

**Dimensions and Materials**

Model <sup>2)</sup>	Process Connection (A) <sup>1)</sup>	Width Across Flats (B)	Electrical Connection (C)	Overall Height (D)	Screwed Fitting (E)	Thread Length <sup>3)</sup> (F)	t <sub>max</sub>
7.. (3-pin)	..N8 = 1½" NPT	30 AF	M16x1.5	65 mm	PP	25 mm	190 °F
	..N9 = 2" NPT	36 AF				27 mm	

<sup>1)</sup> Size of process connection must accommodate float diameter

<sup>2)</sup> To be chosen only with resistance output

<sup>3)</sup> Overall Length L includes thread length

**Model 9: Flange According to ANSI  
B 16.5 150 lbs RF**

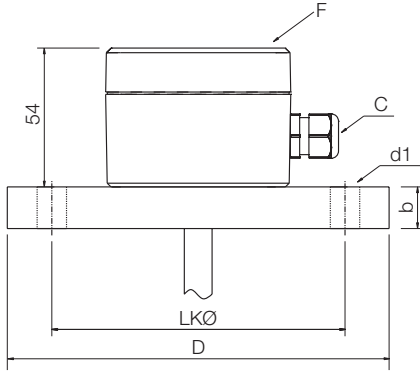

**Dimensions and Materials**

Model	Flange Size 316L SS <sup>1)</sup>	D	b	LKØ	d1	Electrical Connection (C)	Housing (F)	t <sub>max</sub>
9..	..A8 = 1½"	127	17.5	98.6	4 x Ø15.7	M16 x 1.5	Al	190°F <sup>2)</sup>
	..A9 = 2"	152.4	19.1	120.7	4 x Ø19.1			
	..A0 = 2½"	177.8	22.4	139.7	4 x Ø19.1			
	..AB = 3"	190.5	23.9	152.4	4 x Ø19.1			
	..AC = 4"	228.6	23.9	190.5	8 x Ø19.1			

<sup>1)</sup> Other materials on request (PP, PVDF, PVC-U)  
<sup>2)</sup> Max. temperature 85°C if transmitter output is selected

**Model L: Aluminum Housing, for ATEX  
Application II 1/2G Ex d II C T6 Ga/Gb**

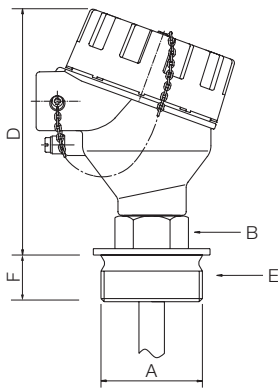

**Dimensions and Materials**

Model	Process Connection (A) <sup>1)</sup>	Width Across Flats (B)	Electrical Connection (C)	Overall Height (D)	Screwed Fitting (E)	Thread Length <sup>2)</sup> (F)	t <sub>max</sub>
L..	..N8 = 1½" NPT	30 AF	M20	145 mm	316L SS	25 mm	190°F
	..N9 = 2" NPT	36 AF				27 mm	

<sup>1)</sup> Size of process connection must accommodate float diameter  
<sup>2)</sup> Overall Length L includes thread length

**Model C/E: Aluminum Housing with Display  
for ATEX Applications II 2 GD Ex d IIC T6**

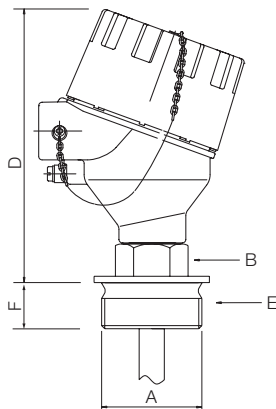

**Dimensions and Materials**

Model <sup>1)</sup>	Process Connection (A) <sup>2)</sup>	Width Across Flats (B)	Electrical Connection (C)	Overall Height (D)	Screwed Fitting (E)	Thread Length <sup>3)</sup> (F)	t <sub>max</sub>
C.. (LCD display)	..N8 = 1½" NPT	30 AF	M20	155 mm	316L SS	25 mm	158°F
	..N9 = 2" NPT	36 AF				27 mm	
E.. (LED display)	..N8 = 1½" NPT	30 AF				25 mm	175°F
	..N9 = 2" NPT	36 AF				27 mm	

<sup>1)</sup> Only with 4...20 mA transmitter. Loop powered display  
<sup>2)</sup> Size of process connection must accommodate float diameter  
<sup>3)</sup> Overall Length L includes thread length

**Model D/R: 316L SS Head with Touch Screen LCD Display**

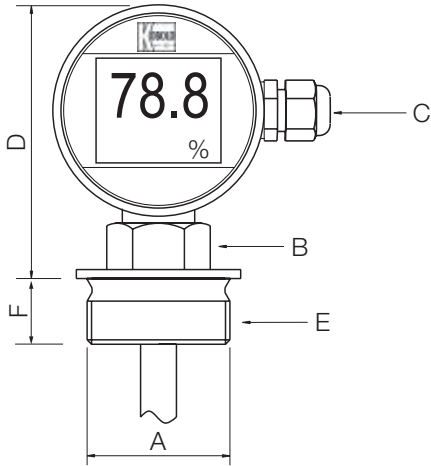

**Dimensions and Materials**

Model <sup>1)</sup>	Process Connection (A) <sup>2)</sup>	Width Across Flats (B)	Electrical Connection (C)	Overall Height (D)	Screwed Fitting (E)	Thread Length <sup>3)</sup> (F)	t <sub>max</sub>
D.. (LCD display)	..N8 = 1½" NPT	30 AF	M16.5	112 mm	316L SS	25 mm	176 °F
	..N9 = 2" NPT	36 AF				27 mm	
R.. (with 2 relay output)	..N8 = 1½" NPT	30 AF				25 mm	
	..N9 = 2" NPT	36 AF				27 mm	

<sup>1)</sup> Only with 4...20 mA transmitter. Loop powered display  
<sup>2)</sup> Size of process connection must accommodate float diameter  
<sup>3)</sup> Overall Length L includes thread length

**Head Selector Table: Float Size Compatibility with Head Type and Fitting Size (Continued on Page 12)**

Head Type/ Fitting Size Order Code	Float M05 (Ø42 mm)	Float M07 (Ø42 mm)	Float M08 (Ø38 mm)	Float M10 (Ø52 mm)	Float M13 (Ø38 mm)	Float M15 (Ø60 mm)	Float M16 (Ø60 mm)	Float M20 (Ø95 mm)
..1N8..	X	X	X		X			
..1N9..	X	X	X	X	X			
..3N8..	X	X	X		X			
..3N9..	X	X	X	X	X			
..4N8..	X	X	X		X			
..4N9..	X	X	X	X	X			
..5N8..	X	X	X		X			
..5N9..	X	X	X	X	X			
..6N8..	X	X	X		X			
..7N8..	X	X	X		X			
..7N9..	X	X	X	X	X			
..LN8..	X	X	X		X			
..LN9..	X	X	X	X	X			
..CN8..	X	X	X		X			
..CN9..	X	X	X	X	X			
..EN8..	X	X	X		X			
..EN9..	X	X	X	X	X			
..DN8..	X	X	X		X			
..DN9..	X	X	X	X	X			
..RN8..	X	X	X		X			
..RN9..	X	X	X	X	X			

No responsibility taken for errors;  
 subject to change without prior notice.



Head Selector Table Continued : Float Size Compatibility with Head Type and Fitting Size

Head Type/ Fitting Size Order Code	Float M05 (Ø42 mm)	Float M07 (Ø42 mm)	Float M08 (Ø38 mm)	Float M10 (Ø52 mm)	Float M13 (Ø38 mm)	Float M15 (Ø60 mm)	Float M16 (Ø60 mm)	Float M20 (Ø95 mm)
For Flanged Connections, Please Ensure that the Float Diameter is less than the Flange Hole Diameter								
..9A8..	X	X	X	X	X			
..9A9..	X	X	X	X	X			
..9A0..	X	X	X	X	X	X	X	
..9AB..	X	X	X	X	X	X	X	
..9AC..	X	X	X	X	X	X	X	X

**Important Note:** The floats may be removed in all models of the MM Series.

Order from: **C A Briggs Company**  
622 Mary Street; Suite 101; Warminster, PA 18974  
Phone: 267-673-8117 - Fax: 267-673-8118  
[Sales@cabriggs.com](mailto:Sales@cabriggs.com) - [www.cabriggs.com](http://www.cabriggs.com)

No responsibility taken for errors; subject to change without prior notice.