

## Industrial OEM Pressure Sensor



measuring  
•  
monitoring  
•  
analyzing

KPA



- $\pm 0.25\%$  of Full Scale Accuracy
- Precision Machined Diaphragm with no Welds or O-Ring Seals
- Pressure Ranges: 0...50 to 0...10000 PSIG
- All Stainless Steel Wetted Parts
- Unique Sensor Fusing Technology
- Offers Exceptional Cycle Life at a Low Cost



Order from: **C A Briggs Company**

622 Mary Street; Suite 101; Warminster, PA 18974

Phone: 267-673-8117 - Fax: 267-673-8118

[Sales@cabriggs.com](mailto:Sales@cabriggs.com) - [www.cabriggs.com](http://www.cabriggs.com)



**Description**

The KOBOLD KPA series pressure sensors combine several unique features to provide an instrument that is tough, accurate, and economical. Both the fitting and the sensing diaphragm are precision machined out of a single piece of 17-4 PH stainless steel. Because there are no welds or seals, the KPA offers an exceptionally high cycle life. The semiconductor strain gauges are kiln fused to the diaphragm for a highly stable molecular bond that resists strain caused by applications with high pressure pulsations. It has a 4-20 mA, 2-wire transmitter and a 1/4" NPT fitting. Other options are available in OEM quantities. The KPA provides significant levels of RFI, EMI, and ESD protection which makes it an ideal choice for industrial applications.

**Specifications**

- Pressure Range:** 0...50 PSIG to 0...10000 PSIG
- Accuracy:** ±0.25% of full scale BFSL
- Temperature Drift:** ±0.0065% of full scale / °F over the compensated temp. range
- Process Temp. Range:** -40...250 °F
- Compensated Temp. Range:** 0...185 °F
- Wetted Materials:** 17-4 PH stainless steel (316L available in OEM quantities)
- Proof Pressure:** 2X measuring range
- Burst Pressure:** 5X the measuring range
- Vibration Resistance:** 20G at 20...200 Hz
- Shock Resistance:** 200G / 11 ms
- Output:**
  - Standard:** 4-20 mA, 2-wire, 9-30 V<sub>DC</sub>
  - Optional:** Others available in OEM quantities
- Electrical Connection:**
  - Standard:** Mini-DIN 43650C
  - Optional:** Others available in OEM quantities
- Electrical Protection:** NEMA 4X, IP65

**Applications**

- Advanced HVAC Systems
- Refrigeration Systems
- Automotive Test Stands
- Industrial Process Control
- Pumps and Compressors
- Hydraulic/Pneumatic Systems
- Agriculture Systems
- Energy Generation and Management



**Dimensions**

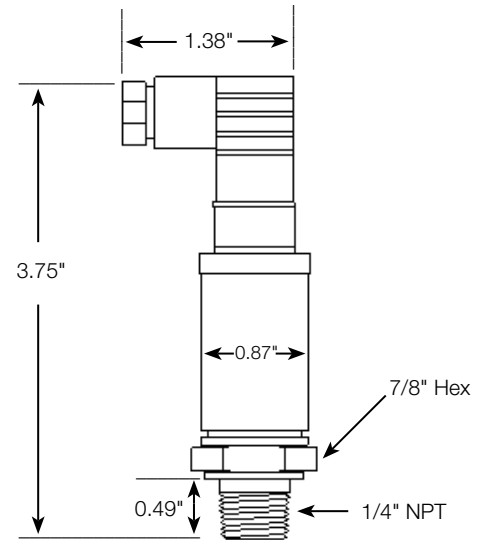

**Order Details**

Range (PSIG)	Model Number	Range (PSIG)	Model Number
0...50	KPA-565P055	0...1000	KPA-565P115
0...100	KPA-565P065	0...3000	KPA-565P140
0...200	KPA-565P085	0...5000	KPA-565P150
0...300	KPA-565P090	0...10000	KPA-565P175
0...500	KPA-565P100	---	