



Thermal Mass Flowmeter

for compressed air and gases



measuring
•
monitoring
•
analysing

KMT



- Measuring range: 0.32 ... 63 Nm³/h - 263.4 ... 263 350 Nm³/h
- Accuracy: ± 1.5% of reading + 0.5% of full scale (≤ DN50) or ± 1.5% of reading + 0.8% of full scale (DN65 ... DN700)
- p_{max}: 16 bar; t_{max}: 80 °C
- Connection: R1½" ... R2" ball valve (≤ DN50) or R1½" male for insertion (DN65 ... DN700)
- Analogue output: 0 - 10V or 0(4) ... 20 mA
- Switching /pulse output
- Option: digital display
- Non-return protection device for secure mounting (DN65 ... DN700)
- Mounting and demounting under pressure without process interruption (with KMT-4)
- Simple and exact positioning
- Installation under pressure (with KMT-4)



Order from: **C A Briggs Company**

622 Mary Street; Suite 101; Warminster, PA 18974

Phone: 267-673-8117 - Fax: 267-673-8118

Sales@cabriggs.com - www.cabriggs.com

Description

The flowmeter of the series KMT, based on the measurement principle of thermal mass flow, is ideally suited for the measurement of flow of compressed air and gases in pipes with sizes from DN 15 ... DN 700. Measurement of for instance the usage of compressed air, nitrogen, CO₂, O₂ or other non-corrosive, non-flammable gases.

The KMT is setting new standards in terms of measurement accuracy and reproducibility thanks to its application specific adjustment during production. This flowmeter is adjusted under a pressure of 7 bar (abs) (DN 15...DN50) or 9 bar (abs) (DN 65...DN700). Adjusting the device specifically for its application has the advantage of keeping the actual flow speed in the pipeline low even with very large flow quantities. Thanks to the more stable flow profile, this low flow speed facilitates a much better degree of reproducibility and accuracy than if the device were adjusted conventionally under normal pressure, as flow speeds up to 200 Nm/s can often no longer be controlled under conventional adjustment pressures.

The core design of the flowmeter is based on the hot film sensor element, which is produced using the most modern thin film technology and has already proven itself time and time again in the automotive industry. This flow sensor features excellent long-term stability, a fast response time and an extremely high degree of reliability.

Two outputs are available, for further processing of the measurement data. Depending on the application, these outputs can be configured as analogue (current or voltage), switch output or as pulse output for the measurement of the consumption.

The KMT has an integrated counter for consumption. The consumed amount is shown on the display and the saved value is not lost even after power outage. The availability of the consumption amount as a free configurable pulse output is another helpful feature.

Functions

The flowmeter KMT consist of the transmitter and the mounting valve (only for KMT-1/2/3). The transmitter is modular and consist of the probe and the signal conditioner. The measurement probe contains the sensor element and the measurement electronics, in which the data of the factory calibration is stored. The enclosure with the signal conditioning is mounted either on the measurement probe (compact) or is remote with a sensor cable up to 10 meter (33 feet). The mounting valve assembly for KMT-1/2/3 allows for the easy and reliable installation within the pipeline. The high measurement accuracy is guaranteed by the accurate, reproducible positioning of the probe within the mounting valve. (See design KMT-1/2/3).

Non-return protection for secure mounting for KMT-4

The non-return protection combines three functions in one device:

- **Non-return protection**

The sensor can only be pushed in one direction during installation. The sensor cannot return at all, even if it is released.

- **Seal**

By means of an encapsulated O-ring, no compressed air can escape under pressure during assembly.

- **Precise positioning**

The precise positioning with respect to immersion depth and orientation is easy to perform, guaranteeing accurate measurement results.

For optimum adaptation to different measurement tasks, you can choose between two measuring ranges 0.2...100 or 0.2...200 Nm/s and three different probe lengths with a maximum immersion depth of 165/315/465 mm. The inner diameter of the distribution pipe which is measured can be entered via the USB port and the included configuration software for pipe sizes from DN 65 to DN 300.

An optional tapping sleeve for KMT-4 allows the subsequent assembly of the sensor into existing pipelines, and this without interrupting the supply systems.

Areas of Application

- Measurement of consumption of compressed air
- Compressed air counter
- Mass flow measurement of industrial gases

Design KMT-1/2/3

1 Transmitter

- 1 a Enclosure with signal conditioning and optional display
- 1 b Measurement probe with sensor and measurement electronics

2 Mounting ball valve

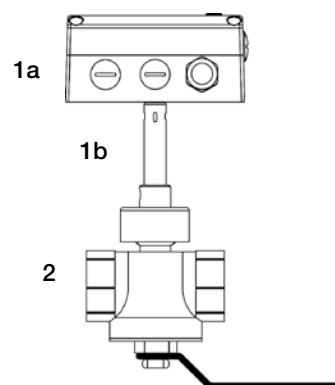

The ball valve assembly allows for the exact alignment of the sensing head within seconds during instalment and removal, with only interrupting the process flow for a short moment. The ball valve assembly is suitable for pressures up to 16 bar (PN 16) and available for pipe diameters DN 15 (1/2") to DN 50 (2"). During installation in the pipeline, observe the required inlet and outlet paths as given in the operating instructions.



Design KMT-4

The evaluation electronics communicates digitally with the probe and can be located up to 10 m (32.8 ft) from the probe.

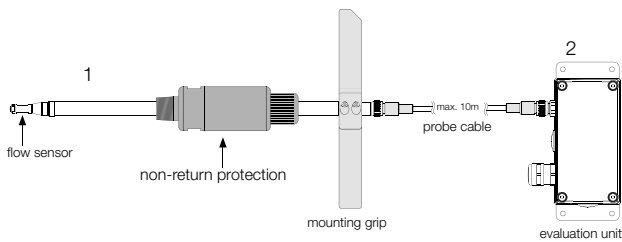

Configuration software

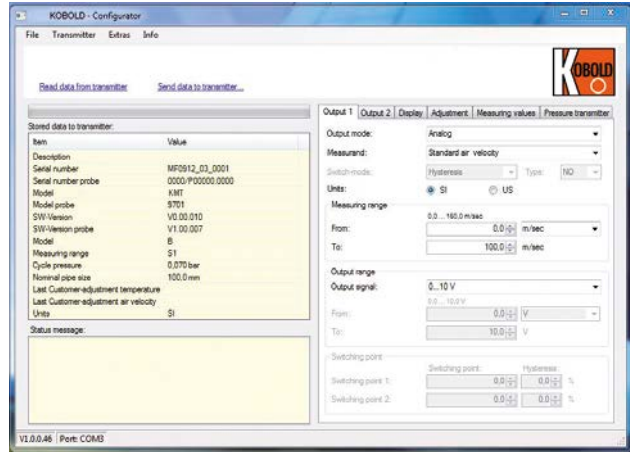

Assembly KMT-4 (DN 65 ... DN 300)

With the right accessories, the KMT-4 flowmeter can be easily integrated into any measurement task.

An assembly without welding and drilling into the pressurised supply line and without flow interruption can be implemented very easily with the tapping sleeve.

An optional 1/2" ball valve on the tapping sleeve enables the installation and removal of the sensor without interrupting the flow in the compressed air line. The ball valve on the tapping sleeve closes the measuring point pressure-tight after removing the flowmeter. Regular calibration, without taking into account the device downtime, is therefore always an option.

The flowmeter can be configured conveniently, to meet the requirements of the application with the standard configuration software and the integrated USB interface.

Functionality

- Configuration of the output (scale/set point)
- Setting the pipe diameter
- 2-point user calibration for flow and temperature
- Readout of the counter values
- Reset of min / max values and counter
- Indication of the measurement value



Measurement of consumption (totaliser)

The KMT holds an integrated counter for the usage. The amount is stored and the data will not be lost due to a power outage. The availability of the consumption amount as a free configurable pulse output is another helpful feature.



Technical Data

Measured flow: volumetric flow at standard conditions acc. DIN 1343
 $P_0 = 1013.25 \text{ mbar}$;
 $t_0 = 0^\circ\text{C}$ (273.15 K)

Measuring range		KMT-x1...	KMT-x2...
Standardised volumetric flow (air)	DN 15	0.32...63 Nm ³ /h	0.32...126 Nm ³ /h
	DN 20	0.57...113 Nm ³ /h	0.57...226 Nm ³ /h
	DN 25	0.90...176 Nm ³ /h	0.90...352 Nm ³ /h
	DN 32	1.45...289 Nm ³ /h	1.45...578 Nm ³ /h
	DN 40	2.26...452 Nm ³ /h	2.26...904 Nm ³ /h
	DN 50	3.50...700 Nm ³ /h	3.50...1400 Nm ³ /h
Standardised flow (air, nitrogen, CO ₂ , argon)	≤DN 50	0.5...100 Nm/s	0.5...200 Nm/s
Standardised flow (Oxygen)	≤DN 25	0.5...100 Nm/s	0.5...200 Nm/s

Flow measuring range in dependence on pipe diameter (KMT-4)

Pipe		Inner Ø	Measuring range	
			KMT-41	KMT-42
	inch	mm	0.2...100 Nm/s	0.2...200 Nm/s
DN65	2½"	70.3	2.8...1397 Nm ³ /h	2.8...2793 Nm ³ /h
DN80	3"	82.5	3.8...1923 Nm ³ /h	3.8...3847 Nm ³ /h
DN100	4"	107.1	6.5...3242 Nm ³ /h	6.5...6483 Nm ³ /h
DN125	5"	131.7	9.8...4902 Nm ³ /h	9.8...9803 Nm ³ /h
DN150	6"	159.3	14.3...7171 Nm ³ /h	14.3...14343 Nm ³ /h
DN200	8"	206.5	24.1...12051 Nm ³ /h	24.1...24101 Nm ³ /h
DN250	10"	260.4	38.3...19163 Nm ³ /h	38.3...38325 Nm ³ /h
DN300	12"	309.7	54.2...27105 Nm ³ /h	57.8...57840 Nm ³ /h
DN350	14"	339.6	65.2...32591 Nm ³ /h	65.2...65183 Nm ³ /h
DN400	16"	388.8	85.4...42719 Nm ³ /h	85.4...85438 Nm ³ /h
DN500	20"	486	133.5...66749 Nm ³ /h	133.5...133498 Nm ³ /h
DN600	24"	585	193.4...96712 Nm ³ /h	193.4...193425 Nm ³ /h
DN700	28"	682.6	263.4...131675 Nm ³ /h	263.4...263350 Nm ³ /h

Accuracy (in air at 7bar (abs) (and 23 °C for KMT-1/2/3 i.e. ≤DN50)*: ± 1.5 % of reading + 0.5 % of full scale

Accuracy (in air at 9 bar (abs) (and 23 °C for KMT-4 i.e. DN65...DN300)*: ± 1.5 % of reading + 0.8 % of full scale

Temperature coefficient: ± 0.1 % of reading / °C
 Pressure coefficient**: + 0.5 % / bar
 Response time t_{90} : < 1 s
 Sample rate: 0.5 s
 Measuring range: -20...80 °C
 Accuracy (at 20 °C): ± 0.7 °C

Input: optional pressure compensation 4 - 20 mA (2-wire; 14.2...16 V_{DC}) for pressure sensor

Outputs: output signal and display ranges are freely scalable

Analogue output
 Voltage: 0 - 10 V max. 1 mA
 Current (3-wire): 0 - 20 mA and 4 - 20 mA RL < 500 Ω

Switching output: potential-free max. 44 V_{DC}, 500 mA switching capacity

Pulse output: totaliser, pulse length: 0.02...2 sec.

Digital interface: USB (for configuration)

Electrical connection: Cable entry M 16 x 1.5
 Cable power supply: 18 - 30 V_{AC/DC}
 Current consumption: max. 200 mA (with display)

Temperature range
 Ambient temperature: -20...60 °C (-4...140 °F)
 Medium temperature: -20...80 °C (-4...176 °F)
 Storage temperature: -20...60 °C (-4...140 °F)

Nominal pressure: PN16 (232 PSI)
 Humidity: no condensation
 Medium: compressed air or non corrosive gases

Display: 2 lines LC-Display, backlighting

Electromagnetic compatibility: EN61326-1 Industrial Environment, EN61326-2-3

Material
 Housing: metal (AlSi₃Cu)
 Probe: stainless steel
 Sensor head: stainless steel/glass
 Ball valve (KMT-1/2/3): brass
 Non-return protection (KMT-4): brass

Housing protection class: IP65/Nema 4

* The accuracy statement includes the uncertainty of the factory calibration with an enhancement factor $k = 2$ (2-times standard deviation). The accuracy was calculated in accordance with EA-4/02 and with regard to GUM (Guide to the Expression of Uncertainty in Measurement).

**The pressure dependence is + 0.5 % / bar. The KMT is calibrated at 7 bar (abs). Thus the error at 7 bar = 0 (e. g. additional error at 10 bar = + 1.5 % of reading. This error can be corrected by entering the actual system pressure (with the configuration software).

The following gases can be measured by the flowmeter KMT

- Air
- Nitrogen
- Carbon dioxide
- Argon
- Oxygen

Use only oil and fat free units for medium oxygen and follow the corresponding safety regulations.

Flow measuring range in dependence on working pressure (\leq DN 50)

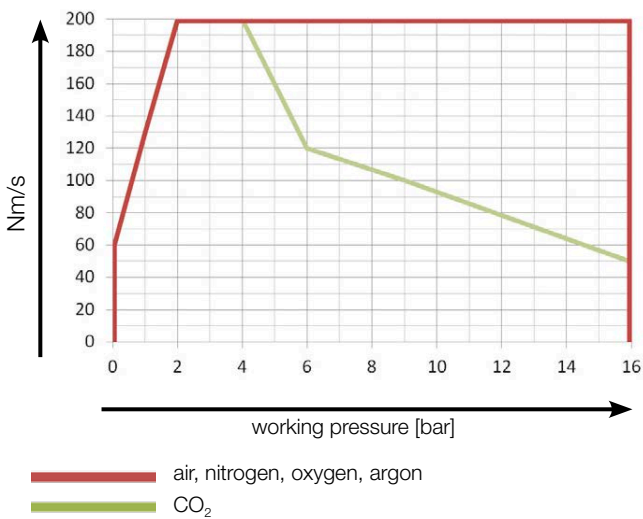

Formula to calculate the standard volumetric flow

$$V_0 = V \times id^2 \times \pi / 4 \times 3600$$

\dot{V}_0 = standardised volumetric flow [m³/h]

\dot{V}_0 = standardised flow [m/s]

id = inner pipe diameter [m]

π = 3.1415

Connection Diagram

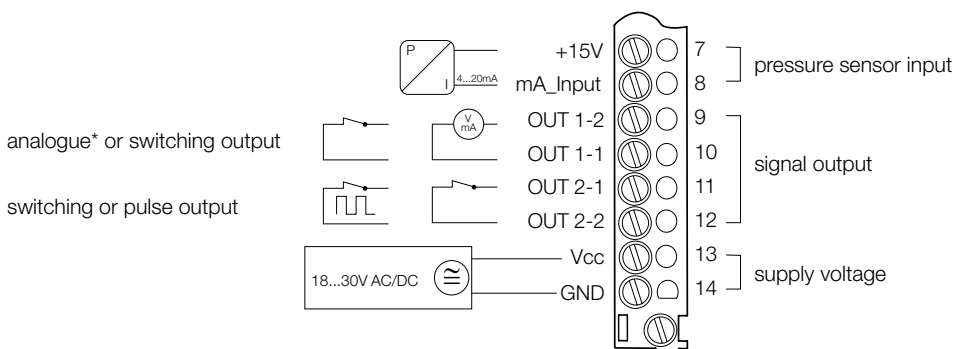

* With analogue output OUT 1-1 is connected with GND. Switching and pulse output are potential-free



Order Details (Example: **KMT-1 14 R 0 0 L 1 N Q 1**)

Model	Measuring range / Installation length (only KMT-4)	Connection	Display	Cable length Sensor / Electronic
KMT-1... Sensor compact, direction of flow from right to left KMT-2... Sensor compact, direction of flow from left to right KMT-3... remote probe, according to installation (\leq DN50)	14 = 0.32 ... 63 Nm ³ /h for pipe DN 15 (1/2")	R = thread-ball valve with G thread N³ = thread-ball valve with NPT thread		
	24 = 0.32 ... 126 Nm ³ /h for pipe DN 15 (1/2")			
	15 = 0.57 ... 113 Nm ³ /h for pipe DN 20 (3/4")			
	25 = 0.57 ... 226 Nm ³ /h for pipe DN 20 (3/4")			
	16 = 0.90 ... 176 Nm ³ /h for pipe DN 25 (1")			
	26 = 0.90 ... 352 Nm ³ /h for pipe DN 25 (1")			
	17 = 1.45 ... 289 Nm ³ /h for pipe DN 32 (1 1/4")			
	27 = 1.45 ... 578 Nm ³ /h for pipe DN 32 (1 1/4")			
	18 = 2.26 ... 452 Nm ³ /h for pipe DN 40 (1 1/2")			
	28 = 2.26 ... 904 Nm ³ /h for pipe DN 40 (1 1/2")			
	19 = 3.50 ... 700 Nm ³ /h for pipe DN 50 (2")			
	29 = 3.50 ... 1400 Nm ³ /h for pipe DN 50 (2")			
KMT-4 remote probe (DN65 ... DN700)	(see technical details for flow measuring range in dependence on pipe diameter)	F = R1/2" male at immersion probe	0 = without Display 1 = LCD-Display	0 = without 2¹⁾ = 2 m with plug M 12, 4 pin 5¹⁾ = 5 m with plug M 12, 4 pin Z¹⁾ = 10 m with plug M 12, 4 pin
	10 = 2.8 ... 1397 Nm ³ /h for pipe DN 65 (2 1/2")/165 mm			
	20 = 2.8 ... 2793 Nm ³ /h for pipe DN 65 (2 1/2")/165 mm			
	1B = 3.8 ... 1923 Nm ³ /h for pipe DN 80 (3")/165 mm			
	2B = 3.8 ... 3847 Nm ³ /h for pipe DN 80 (3")/165 mm			
	1C = 6.5 ... 3242 Nm ³ /h for pipe DN 100 (4")/165 mm			
	2C = 6.5 ... 6483 Nm ³ /h for pipe DN 100 (4")/165 mm			
	1D = 9.8 ... 4902 Nm ³ /h for pipe DN 125 (5")/315 mm			
	2D = 9.8 ... 9803 Nm ³ /h for pipe DN 125 (5")/315 mm			
	1E = 14.3 ... 7171 Nm ³ /h for pipe DN 150 (6")/315 mm			
	2E = 14.3 ... 14343 Nm ³ /h for pipe DN 150 (6")/315 mm			
	1F = 24.1 ... 12051 Nm ³ /h for pipe DN 200 (8")/315 mm			
	2F = 24.1 ... 24101 Nm ³ /h for pipe DN 200 (8")/315 mm			
	1G = 38.3 ... 19163 Nm ³ /h for pipe DN 250 (10")/315 mm			
	2G = 38.3 ... 38325 Nm ³ /h for pipe DN 250 (10")/315 mm			
	1H = 54.2 ... 27105 Nm ³ /h for pipe DN 300 (12")/315 mm			
	2H = 54.2 ... 54211 Nm ³ /h for pipe DN 300 (12")/315 mm			
	1J = 65.2 ... 32591 Nm ³ /h for pipe DN 350 (14")/465 mm			
	2J = 65.2 ... 65183 Nm ³ /h for pipe DN 350 (14")/465 mm			
	1K = 85.4 ... 42719 Nm ³ /h for pipe DN 400 (16")/465 mm			
	2K = 85.4 ... 85438 Nm ³ /h for pipe DN 400 (16")/465 mm			
	1L = 133.5 ... 66749 Nm ³ /h for pipe DN 500 (20")/465 mm			
2L = 133.5 ... 133498 Nm ³ /h for pipe DN 500 (20")/465 mm				
1M = 193.4 ... 96712 Nm ³ /h for pipe DN 600 (24")/465 mm				
2M = 193.4 ... 193425 Nm ³ /h for pipe DN 600 (24")/465 mm				
1N = 263.4 ... 131675 Nm ³ /h for pipe DN 700 (28")/465 mm				
2N = 263.4 ... 263350 Nm ³ /h for pipe DN 700 (28")/465 mm				

Order Details (continued) next page

Order from: **C A Briggs Company**

622 Mary Street; Suite 101; Warminster, PA 18974

Phone: 267-673-8117 - Fax: 267-673-8118

Sales@cabriggs.com - www.cabriggs.com



Order Details (continued)

Medium	Unit	Physical Size Output 1	Physical Size Output 2	Output 1 / Output 2
L = air N = nitrogen C = CO ₂ A = argon S²⁾ = oxygen (only up to DN25) Y = other gases (on request)	1 = SI units 2 = US units (e. g. SCFM, SFPM)	N = standard volume flow [Nm ³ /h] (Standard setting) T = temperature [°C] M = mass flow [kg/h] V = standard flow [Nm/s]	Q = consumption [Nm ³] (Standard setting)	2 = switching-/counting pulse output 3 = analogue output 0-10 V/ counting pulse output 4 = analogue output 4-20 mA/ counting pulse output (Standard)
			N = standard volume flow [Nm ³ /h] T = temperature [°C] M = mass flow [kg/h] V = standard flow [Nm/s]	1 = 2 x Switching output 7 = analogue output 0-10 V/ switching output 8 = analogue output 4-20 mA/ switching output

¹⁾ Only for KMT-3... and KMT-4...

²⁾ Sensor head and ball valve (wetted parts) are oil-and grease-free. Warning: only oil-and grease-free cleaned devices may be used for oxygen

³⁾ Not possible with 1/2" and 1 1/4"

Order Details Replacement Sensor (Example: ERS-KMT-S 1 1 4 K)

Model	Design	Measuring range	Measuring section pipe diameter	Mounting
ERS-KMT-S	1 = sensor compact (direction of flow right to left) 2 = sensor compact (direction of flow left to right) 3 = remote probe (≤DN50) 4 = remote probe (DN65...DN700)	1 = low 2 = high	4 = DN15 5 = DN20 6 = DN25 7 = DN32 8 = DN40 9 = DN50	K = for ball valve
			0 = DN65 B = DN80 C = DN100 D = DN125 E = DN150 F = DN200 G = DN250 H = DN300 J = DN350 K = DN400 L = DN500 M = DN600 N = DN700	F = R1/2" male at immersion probe

Dimensions [mm] (for KMT-1/2/3 i.e. \leq DN 50)

Compact KMT-1..., KMT-2...

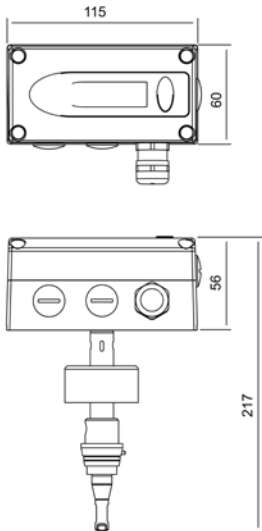

KMT-1...

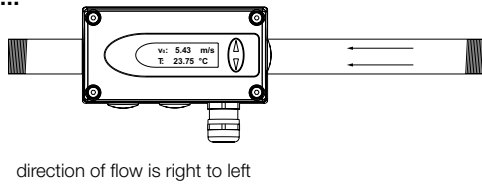

KMT-2...

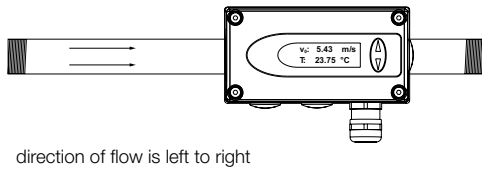

Remote probe KMT-3...

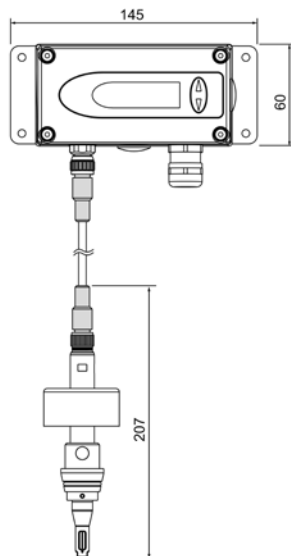

Ball valve for KMT-1/2/3 (Standard delivery scope)

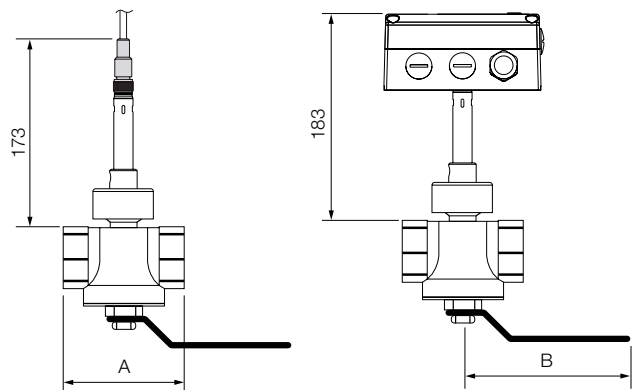
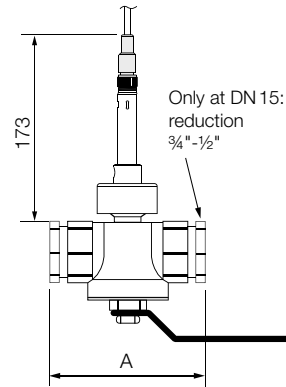

Ball valve	Thread	A [mm]	B [mm]
DN 15	R _p 1/2"	100±8	92
DN 20	R _p or NPT 3/4"	72	92
DN 25	R _p or NPT 1"	83	124
DN 32	R _p 1 1/4"	100	124
DN 40	R _p or NPT 1 1/2"	110	147
DN 50	R _p or NPT 2"	131	147

Female thread:
BSP thread acc. EN 10226 (old DIN 2999) or NPT

Dimensions [mm] (for KMT-4 i.e. DN65...DN300)

Sensor probe

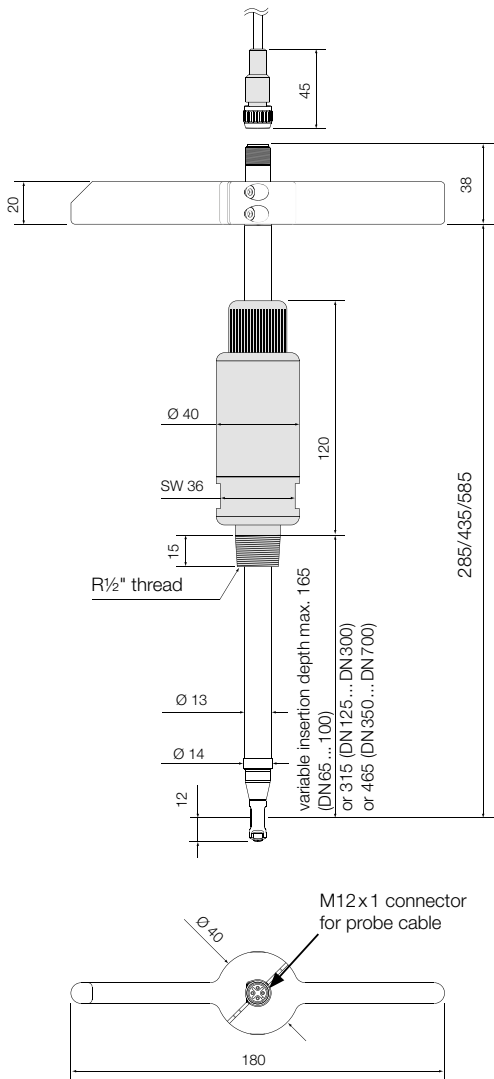

Enclosure - signal conditioning unit

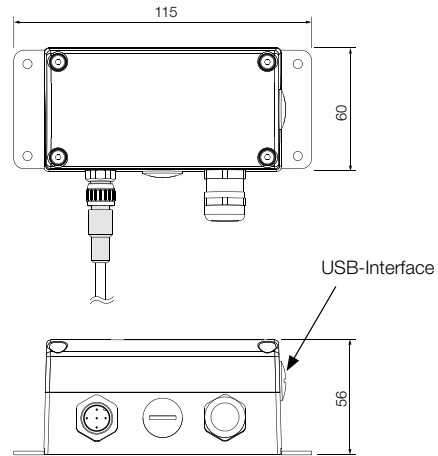

Assembly - insertion depth

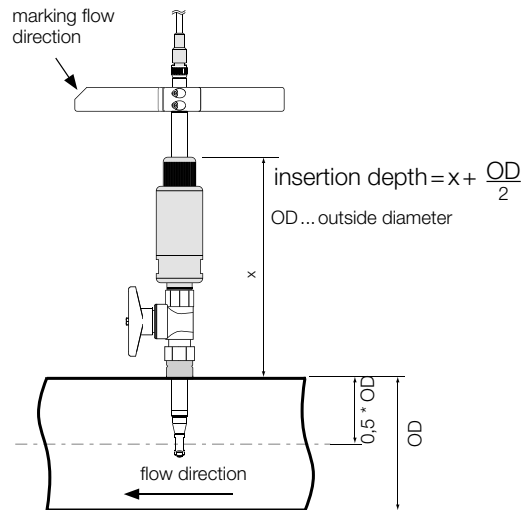

Dimensions [mm] (Accessories for KMT-4 i.e. DN 65... DN300)

Ball valve 1/2" (ERS-KMT-KH)

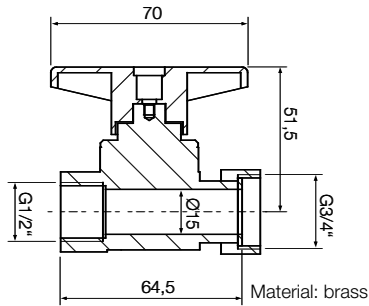

Ball valve 1/2" for parallel measurement (ERS-KMT-KP)

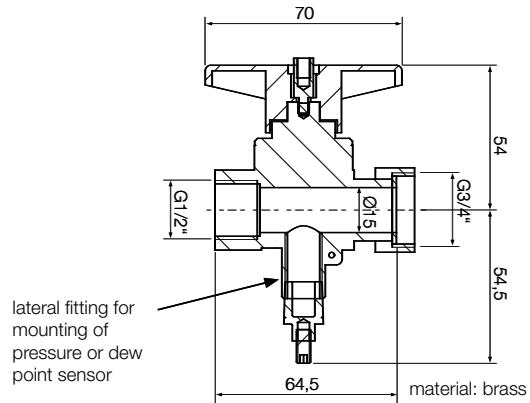

Tapping sleeve (Delivery without ball valve)

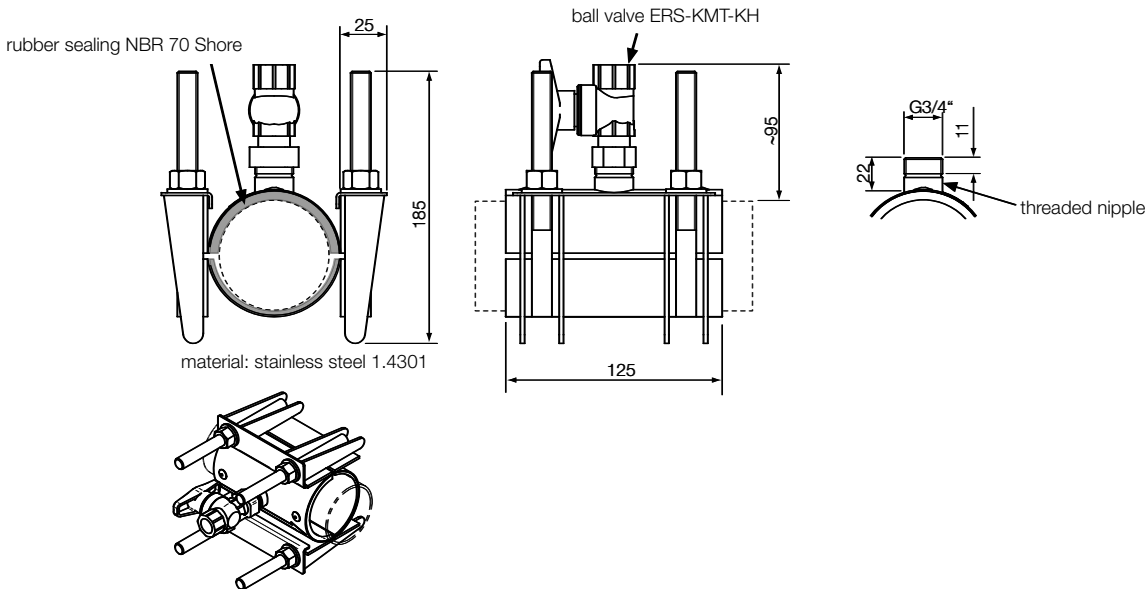

Pipe	Clamping range [mm (inch)]	Max. working pressure
DN 65 (2½")	73-93 (2.87-3.66)	16 bar (PN16) (232psi)
DN 80 (3")	86-106 (3.39-4.17)	16 bar (PN16) (232psi)
DN 100 (4")	107-127 (4.21-5.00)	16 bar (PN16) (232psi)
DN 125 (5")	128-148 (5.04-5.83)	16 bar (PN16) (232psi)
DN 150 (6")	149-171 (5.87-6.73)	16 bar (PN16) (232psi)
DN 200 (8")	216-236 (8.50-9.29)	16 bar (PN16) (232psi)
DN 250 (10")	260-280 (10.24-11.02)	10 bar (PN10) (145psi)
DN 300 (12")	315-335 (12.40-13.19)	10 bar (PN10) (145psi)

Order from: **C A Briggs Company**

622 Mary Street; Suite 101; Warminster, PA 18974

Phone: 267-673-8117 - Fax: 267-673-8118

Sales@cabriggs.com - www.cabriggs.com