

Paddle Wheel Flowmeter



measuring
•
monitoring
•
analyzing

DPE



- Measuring Ranges: 1.5...8 GPM to 15...200 GPM
- Measuring Accuracy: $\pm 2.5\%$ of Full Scale
- p_{\max} : 580 PSIG
- t_{\max} : 176 °F
- Connection: 1/2" NPT...3" NPT
- Material: Brass, Stainless Steel
- Output: Pulse, 4-20 mA, LED or LCD Displays, Contacts



KOBOLD companies worldwide:

Order from: **C A Briggs Company**
622 Mary Street; Suite 101; Warminster, PA 18974
Phone: 267-673-8117 - Fax: 267-673-8118
Sales@cabriggs.com - www.cabriggs.com



Description

The DPE series paddle wheel flowmeters are an economical yet reliable solution for measuring liquid flows in pipes up to 3 inches in diameter. The unique "insertion" impeller design protrudes minimally into the flow stream, which minimizes head loss and allows for measurement of dirty liquids and liquids with high solid content, without risk of failure. They feature a PVDF impeller supported on a sapphire bearing system which provides an exceptionally long life and excellent chemical resistance properties. They are available with either brass or stainless steel threaded bodies. A Hall effect sensor detects the passing of permanent magnets imbedded in the impeller blades. The output of the Hall sensor is converted to a linear pulse or 4-20 mA signal. Optionally, a variety of displays and controllers are available to provide flow rate indication, analog outputs and programmable setpoint switches. The combination of simple, reliable design and the variety of body materials and electronics makes the DPE a sure solution for the toughest flow metering applications.

Fields of Application

- Monitoring Cooling Water
- General Mechanical Engineering
- Waste Water Treatment
- Heavy Goods Industry
- Chemical Industry

Technical Details

Measuring Accuracy: ± 2.5% of Full Scale
Process Temperature: -10...176°F
Ambient Temperature: Max. 176°F
Max. Op. Pressure: 580 PSIG / 68°F
Max. Pressure Loss

DPE-..50: 0.73 PSIG
DPE-..55, DPE-..60: 0.44 PSIG
DPE-..65: 0.58 PSIG
DPE-..70: 0.29 PSIG
DPE-..75: 0.15 PSIG

Protection: IP 65

Materials

Housing: Brass
 316 Stainless Steel

Seals

Brass Version: NBR
SS Version: FKM
Turbine Wheel: PVDF
Axle: 316 Stainless Steel
Bearing: Sapphire

Electronics

Frequency Output (..F300)

Power Supply: 12 - 28 V_{DC}
Power Consumption: 10 mA
Pulse Output: PNP, Open Collector, Max. 25 mA
Electrical Conn.: Plug Connector M12x1

Frequency Output with Frequency Divider (..F390)

Power Supply: 24 V_{DC} ±20%
Power Consumption: 15 mA
Pulse Output: PNP, Open Collector, Max. 25 mA
Electrical Conn.: Plug Connector M12x1
Division Ratio: 1...¹/₁₂₈, Factory Set

Analog Output (..L342, ..L343, ..L442)

Power Supply: 24 V_{DC} ±20%
Output: 4-20 mA, 2- or 3-wire
Max. Load: 500 Ω
Electrical Conn.: Plug Connector M12x1 or DIN 43 650
Optional: Plug-on Display (with Plug Connec. DIN 43 650, 2-wire)

Compact Electronics (..C3xx)

Display: 3-segment LED
Analog Output: 4...20 mA Adjustable, Max. 500 W
Switching Outputs: 1 (2) Semiconductor PNP or NPN, Factory Set
Contact Operation: N/C/N/O Contact, Programmable with 2 Buttons
Setting: 24 V_{DC} ±20%, 3-wire Technology, Approx. 100 mA
Supply:
Electrical Conn.: Plug Connector M12x1

Pointer Indicator with Analog Output (..Z340)

Housing: Aluminum
Display: Moving-Coil Instrument, 240° Display
Power Supply: 24 V_{DC} ±20%
Output: 4-20 mA, 3-wire
Max. Load: 250 Ω
Electrical Conn.: Plug Connector M12x1

ADI-1 Totalizing Electronic (..Kx42)

Display: 270° Bargraph, 5-Digit Digital Display
Analog Output: 4...20 mA, 0-10 V_{DC}
2 Switching Outputs: Relay /Changeover Contact, Max. 250 V_{AC}/5A Resistive Load, Max. 30 V_{DC} / 5A with 4 buttons
Setting:
Power Supply: 100...240V_{AC} ± 10% or 18...30V_{AC}/10...40V_{DC}
Electrical Conn.: Pluggable Terminal Block via Cable Gland

ZED Totalizing Electronic (..E34R)

Display: LCD, 2 x 8 Digit, Illuminated, Grand Total, Resettable Total and Flow Quantities Unit Selectable
Analog Output: 4...20 mA Adjustable
Load: Max. 500 Ω
Switching Output: 2 Relays, Max. 250V/5A/1000 VA
Settings: via 4 Buttons
Functions: Reset, MIN/MAX Memory, Flow Monitor, Monitoring for Part and Total Quantity, Language
Power Supply: 24 V_{DC} ± 20%, 3-wire
Power Consumption: Approx. 170 mA
Electrical Conn.: Pluggable Terminal Block via Cable Gland

ZED Batching Electronic (..G34R)

Display: LCD, 2 x 8 digit, Illuminated, Grand Total, Resettable Total and Flow Quantities Unit Selectable
Analog Output: 4...20 mA, Scalable
Load: Max. 500 Ω
Switching output: 2 Relays, Max. 250V/5A/1000 VA
Settings: via 4 Buttons
Functions: Batching (Relay S2), Start, Stop, Reset, Fine Batching, Correction Amount, Flow Switch, Total Quantity, Language
Power Supply: 24 V_{DC} ± 20%, 3-wire
Power Consumption: Approx. 170 mA
Electrical Conn.: Pluggable Terminal Block via Cable Gland



Order Details (Example: **DPE-1160 N6 K042**)

Model			Evaluating Electronics
(GPM)	Material		Process Connection
	Brass	Stainless Steel	
1.5...8	DPE-1150..	DPE-1250..	..N4.. = 1/2" NPT
3.0...13	DPE-1155..	DPE-1255..	..N5.. = 3/4" NPT
5.5...20	DPE-1160..	DPE-1260..	..N6.. = 1" NPT
6.6...65	DPE-1165..	DPE-1265..	..N8.. = 1 1/2" NPT
8...90	DPE-1170..	DPE-1270..	..N9.. = 2" NPT
15...200	DPE-1175..	DPE-1275..	..NB.. = 3" NPT

Accessory Cables
807.037 = 4-Pin Micro-DC Connector with 6-foot Cable for Output Types F300, F390, L342, L343, & Z340
807.007 = 5-Pin Micro-DC Connector with 6-foot Cable for Output Types C3xx

Frequency Output
 ..F300 = Frequency Output, Plug Connector M12 x 1
 ..F390 = Frequency Divider 1...1/128, Plug Connector M12x 1

Analog Output
 ..L342 = 4-20 mA Output, 2-wire, M12 x 1 Plug Connector
 ..L343 = 4-20 mA Output, 3-wire, M12 x 1 Plug Connector
 ..L442 = 4-20 mA Output, 2-wire, Plug Connector DIN 43 650

Compact Electronic*
 ..C30R = LED-Display, 2 x Open Collector, PNP, Plug Connector M12 x 1
 ..C30M = LED-Display, 2 x Open Collector, NPN, Plug Connector M12 x 1
 ..C34P = LED-Display, 4-20 mA, 1 x Open Collector PNP, Plug Connector M12 x 1
 ..C34N = LED-Display, 4-20 mA, 1 x Open Collector NPN, Plug Connector M12 x 1

Pointer Indication, 240°*
 ..Z340 = 240°-Pointer Indication, 4-20 mA, Plug Connector M12x1

ADI-1 Rate/Totalizing Electronic*
 ..K042 = Bargraph/Digital Display, 100-240 VAC, 4-20mA & 0-10 VDC, 2 SPDT Contacts
 ..K342 = Bargraph/Digital Display, 10-40 VDC, 4-20mA & 0-10 VDC, 2 SPDT Contacts

ZED Rate/Totalizing Electronic*
 ..E34R = LCD, 2x 8-digit, 24 VDC, 4-20 mA, 2 SPDT Contacts

ZED Batching Electronic*
 ..G34R = LCD, 2x 8-digit, 24 VDC, 4-20 mA, 2 SPDT Contacts

* Please specify flow direction when ordering

Plug-on Display for Model DPE...L442
 (2-wire, 4-20 mA Output and DIN Connector)

Description	Order Number
4-Digit LED, Connector DIN 43650, 2-wire, Supply through Analog Output	AUF-1000
As Above with Additional Open Collector Output	AUF-1001



Electrical Connection

DPE-..F.., DPE-..Z.., DPE-..L3.. 3-wire

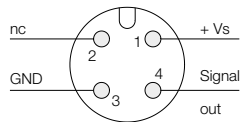

DPE-..C3..

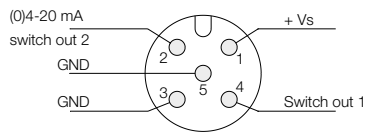

DPE-..Kx42*, ..E34R*, ..G34R*

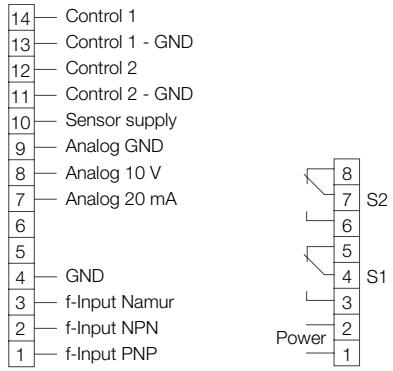

DPE-..L342 2-wire

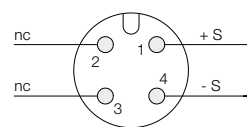

DPE-..L442

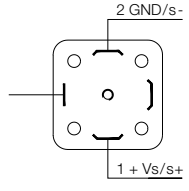

*Note: Consult model specific user manual for exact pin-out designs



Paddle Wheel Flowmeter Model DPE

Dimensions

Model: DPE-..F3x0, ..L34x (with Freq. or Analog Output)

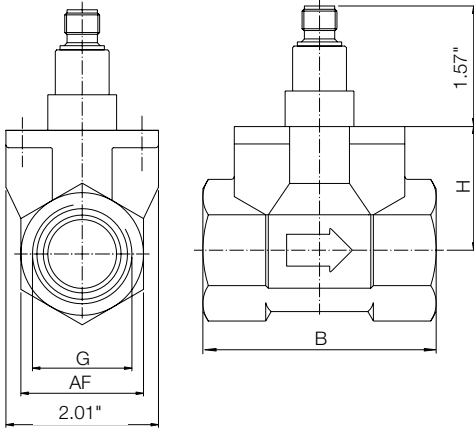

Model: DPE-..Z340 (with Pointer Indication)

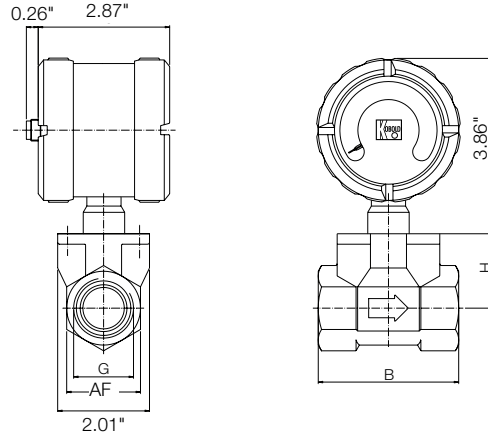

Model: DPE-..C3xx (with Compact Electronics)

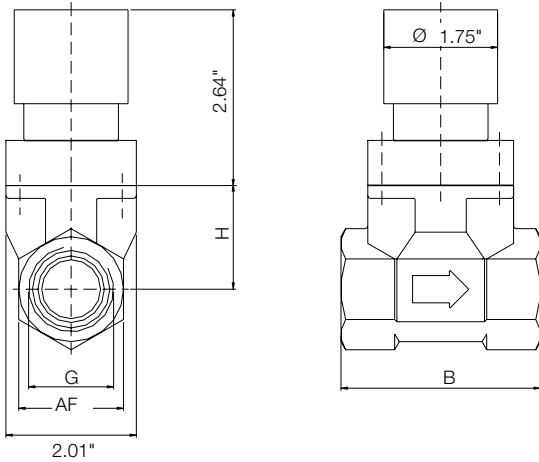

Model: DPE-..Kx42, ..E34R, ..G34R
(with ADI-1 or ZED Evaluating Electronic)

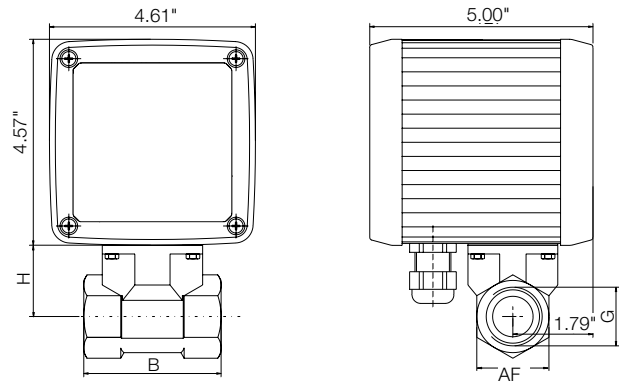

Model: DPE-..L442

(with Analog Output & Optional Plug-on Display)

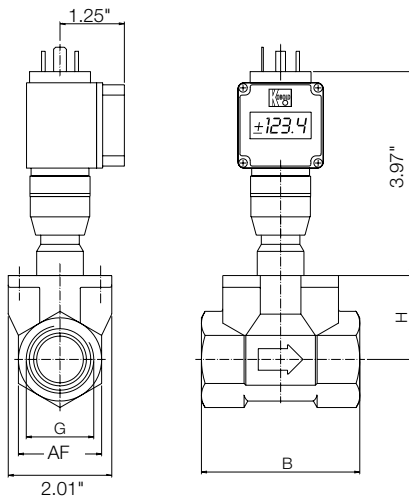

	G	AF	B	H
1/2" NPT	1.06"	1.06"	3.07"	1.57"
3/4" NPT	1.61"	1.61"	3.07"	1.65"
1" NPT	1.61"	1.61"	3.07"	1.65"
1-1/2" NPT	2.17"	2.17"	3.07"	2.24"
2" NPT	2.76"	2.76"	3.19"	2.28"
3" NPT	3.97"	3.97"	4.17"	2.95"

Weights

Sensor		Electronics	
Model	Weight	Model	Weight
1/2"	approx. 1.66 lbs	Frequency Output	0.28 lbs
3/4"	approx. 2.32 lbs	Analog Output	0.28 lbs
1"	approx. 1.99 lbs	Compact Electronic	approx. 1.43 lbs
1-1/2"	approx. 2.65 lbs	Pointer Indication	1.21 lbs
2"	approx. 3.31 lbs	ADI-1 Electronics	3.09 lbs
3"	approx. 6.62 lbs	ZED Electronics	3.09 lbs

No responsibility taken for errors;
subject to change without prior notice.