



Non-Contact Radar Level Transmitter,
80 GHz
- Expert Line -
for liquids and solids



measuring
•
monitoring
•
analysing

NRE-4



- n Measuring range: up to 30 m
- n Connection:
BSP-, NPT-thread male
flange 3" ... 12" (DIN, ANSI, JIS)
- n Material connection:
stainless steel, PP, PVDF, PTFE
- n p_{max} : 40 bar
- n t_{max} : +180°C
- n Accuracy: ± 3 mm
- n Power supply: 12.5 ... 36 V_{DC},
2-wire
- n Output: 4 ... 20 mA HART®, relay
- n Approval: Ex ia (in preparation)

N2



Order from: **C A Briggs Company**

622 Mary Street; Suite 101; Warminster, PA 18974

Phone: 267-673-8117 - Fax: 267-673-8118

Sales@cabriggs.com - www.cabriggs.com



Description

The new NRE-4 non-contact radar level transmitters use the most advanced industrial measurement technology, the 80 GHz FMCW radar. The most fundamental advantage of 80 GHz radars compared to lower frequencies (5...12 GHz and 25 GHz) is the smaller antenna size, better focusability, and narrow beam angle.

It uses the latest technology for measuring liquids, masses, emulsions, and other chemicals widely used in, for example, the water industry, food industry, energy industry, pharmaceutical industry, and chemical industry, which provides measurement results with millimeter accuracy.

It is also excellent for measuring substances prone to vapor formation and liquids with gas blanket or large-particle bulk solids. In addition to the level, volume, and weight measurement functions, this product family also inherits the openchannel flow measurement functions and the threshold functions to eliminate false and interfering echoes. Since no medium is required for millimeter waves to propagate, it can also be used in a vacuum.

The device can also be operated with HART® compliant KOBOLD NUS-NTB-NRM-SW software.

Operating Principle

The reflection of the millimeter-waves is highly dependent on the dielectric constant of the medium. Therefore, the measured medium's dielectric constant (ϵ_r) must be over 1.9 for millimeter-wave level measurement. The measurement principle of a level transmitter with a millimeter-waves signal is based on measuring the reflection's time of flight.

The speed of propagation of millimeter-waves signals in the air, gases, and vacuum is almost constant regardless of temperature and medium pressure, so the measured distance does not depend on the physical parameters of the intermediate medium.

The NRE-4 level transmitter is a continuous-wave frequency modulated radar (FMCW) operating at 80 GHz (W-band). The most obvious advantages of 80 GHz radars over lower frequency (5...12 & 25 GHz) radars are smaller antenna size, better focus, and smaller beam angle. A portion of the millimeter-wave continuous wave energy radiated by the level transmitter antenna is reflected from the measured surface, depending on the material to be measured. The distance of the reflecting surface is calculated with high accuracy by the electronics from the frequency shift of the reflected signal and converted into a distance, level, or volume signal by the electronics.

Features

- 2-wire 80 GHz (W-band) radar
- Measuring range up to 30 m (98.5 ft)
Accuracy of ± 2 mm (± 0.078 "")
- Easy to install due to small antenna diameter
- Plug-in graphic display module
- Horn and plastic encapsulated antennas
- IP67 protection
- User-friendly threshold management
- Ex variant*

* in preparation

Applications

- For measuring the level of liquids, emulsions, and other media
- For large-particle bulk solids
- Storage tanks, chemical tanks, open pits, sumps, wells
- Measurement through a plastic tank roof
- For material prone to vapor formation
- For measuring liquids with a gas blanket
- It can also be used in a vacuum
- Open-channel flow measurement

Areas of Application

- Water and Wastewater Industry
- Energy Industry / Plant Utilities
- Food & Beverage
- Chemical & pharmaceutical Industry
- Agriculture
- Construction materials
- Heavy Industry
- Packaging Industry

Informative r values

Butane (C ₄ H ₁₀)	1.4	Ethers	4.4
LP gas	1.6 ... 1.9	Acetic acid (CH ₃ COOH)	6.2
Kerosene	2.1	Limestone	6.1 ... 9.1
Crude Oil		Ammonia (NH ₃)	17 ... 26
Diesel Oil		Acetone (C ₃ H ₆ O)	21
Benzol (C ₆ H ₆)	2.2	Ethyl alcohol (C ₂ H ₅ OH)	24
Gasoline	2.3	Methyl alcohol (CH ₃ OH)	33.1
Bitumen	2.6	Glycol (C ₂ H ₆ O ₂)	37
Carbon disulfide (CS ₂)		Nitrobenzene (C ₆ H ₅ NO ₂)	40
Clinker	2.7	Glycerin (C ₃ H ₈ O ₃)	41.1
Resin	2.4 ... 3.6	Water (H ₂ O)	80
Cereal Grain	3 ... 5	Sulfuric acid (H ₂ SO ₄) (T = 20 °C [+68 °F])	84

Basic Concepts and Elements

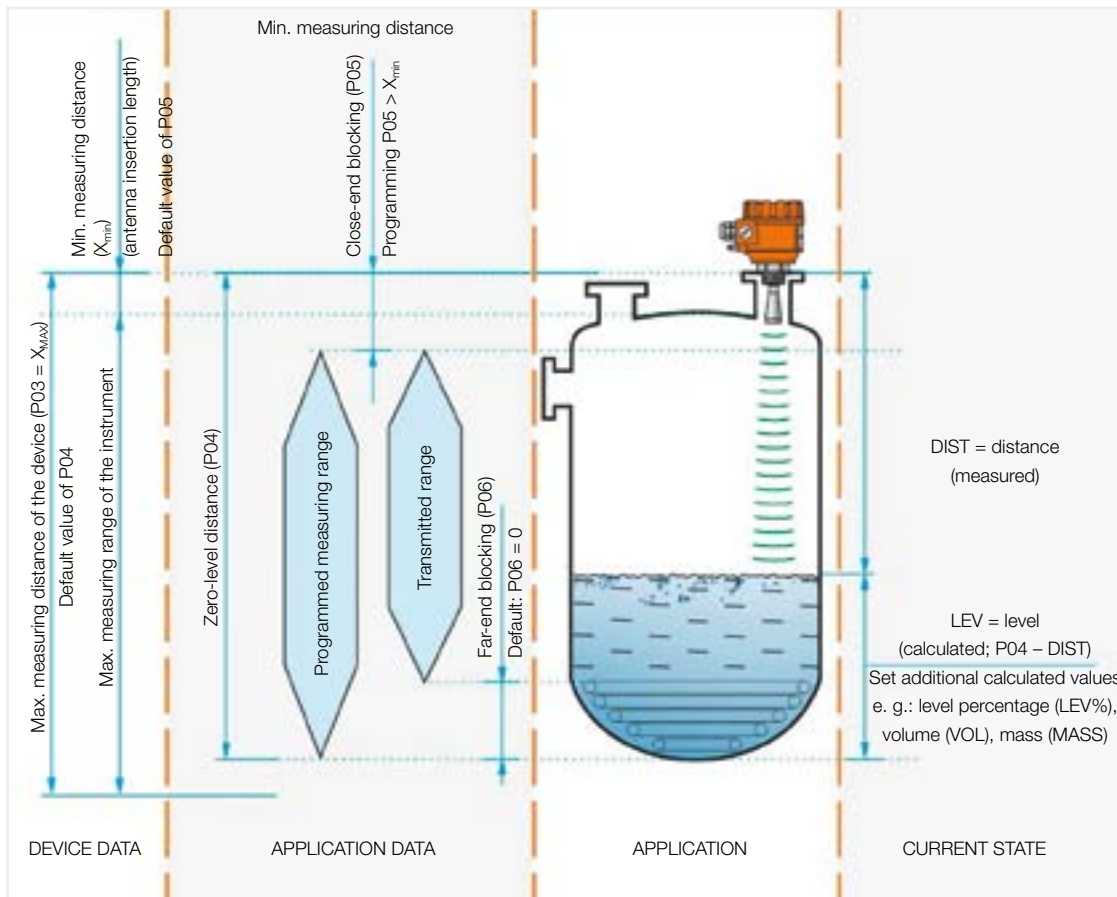



Technical Details

		Plastic housing	Metal housing
Measured values		Distance; calculated values: level, volume, mass, flow	
Signal frequency		77 ... 81 GHz (W-band)	
Measuring range ¹⁾		0 ... 30 m (0 ... 98.5 ft)	
Minimum beam angle ¹⁾		7°	
Lowest ϵ_r of medium		1.9	
Resolution		0.1 mm (0.0039")	
Supply voltage		12.5 ... 36 V _{DC}	
Output	Analog	4 ... 20 mA (3.9 ... 20.5 mA); $R_{i,max} = (U_s - 12 V) / 0.02 A$	
	Digital	Bluetooth® (under development), HART® interface, loop resistance $\geq 250 \Omega$	
	Relay (optional)	SPDT 30 V / 1 A DC; 42 V / 0,5 A AC	
	Service interface	HARTCOM-0 compatible	
	Display	NRM-300P graphic display unit	
Measuring frequency		~1 s	
Antenna diameter ¹⁾		1" (25.4 mm); 1½" (38.1 mm)	
Antenna material ¹⁾		1.4571 stainless steel, or plastic antenna enclosure (PP / PVDF / PTFE)	
Process temperature		-40 ... +80 °C (-40 ... +176 °F)	
Ambient temperature			
Process pressure		PP, PVDF, PTFE antennas: -1 ... 3 bar (-14.5 ... 43.5 psi); Stainless steel antennas: -1 ... 40 bar (-14.5 ... 580 psi)	
Process connection		1", 1½" BSP / NPT	
Ingress protection		IP67	
Electrical connection		2x M20x1.5 plastic cable glands + 2x internally threaded ½" NPT connection for protective pipes, cable outer diameter: Ø7 ... 13 mm (Ø0.3 ... Ø0.5"), wire cross section: maximum 1.5 mm² (AWG15)	
Electrical protection		Overvoltage Class 1; (Class III [SELV])	
Housing material ¹⁾		Plastic (PBT)	Painted aluminium or stainless steel
Weight		1 ... 1.6 kg (2.2 ... 3.5 lb)	Aluminium: 2 ... 2.6 kg (4.4 ... 5.7 lb); stainless steel: 3.3 ... 3.9 kg (7.9 ... 8.6 lb)

¹⁾ Depending on order code

Type-dependent Data

	NRE-41xxR25 NRE-41xxN25	NRE-41xxR40 NRE-41xxN40	NRE-42xxR40 NRE-42xxN40
Dead zone ¹⁾	0 m (0 ft)		
Maximum measuring range ²⁾	10 m (33 ft)		20 m (66 ft)
Accuracy ³⁾	$\pm 5 \text{ mm } (\pm 0.197")$		$\pm 2 \text{ mm } (\pm 0.078")$
Beam angle (-3 dB)	12°	7°	
Antenna insertion length ⁴⁾	80 mm (3.15")		92 mm (3.62")
Process connection	1" BSP / NPT		1½" BSP / NPT

¹⁾ Measured from the tip of the antenna.

²⁾ May be limited in the case of low dielectric constant or non-perpendicular or non-planar media.

³⁾ In the case of an ideal reflecting surface.

⁴⁾ Measured from the sealing plane of the process connection.



Order Details NRE-4 (Example: NRE-4 1 S P R25 A0K 0)

Model	Measuring range	Version	Material Antenna/ Housing
NRE-4 = Radar Level Transmitter, 80 GHz, Horn Type, compact line	1 = 10 m 2 = 20 m 3³⁾ = 30 m	S = Standard H³⁾ = High temperature	P = PP / PBT (glass fibre reinforced) M = 1.4571 / PBT (glass fibre reinforced) S = 1.4571 / aluminium (paint coated) V = PVDF/ PBT (glass fibre reinforced) B = PVDF/ aluminium (paint coated) F = PTFE/ PBT (glass fibre reinforced) (only for range up to 20 m)

Process connection	Output / Display/ Approval	Option
R25 = 1" BSP (only for range 10 m) N25 = 1" NPT (only for range 10 m) R40 = 1½" BSP (only for range 10 m/ 20 m) N40 = 1½" NPT (only for range 10 m/ 20 m) D75¹⁾ = Ø75 mm (2½") prepared for flange FWS²⁾ = prepared for welded flange	A0K = 4...20 mA HART/ without/ without R0K = 4...20 mA HART + relay / without/ without A1K = 4...20 mA HART/ with/ without R1K = 4...20 mA HART + relay / with/ without	0 = without Y = Special option

¹⁾ only 30 m and encapsulated types, flanges available from size DN80 should be ordered separately

²⁾ only for 10 and 20 m ranges, with ½" stainless steel antenna, flange type ZGF to be ordered separately

Accessories

Order Code	Description	Image
HARTCOM-0	HART® USB modem	
NRM-300P	Display	





Order Details ZGF (Example: **ZGF-A1 D51**)

Model	Version	Standard / Flange Material / Form
ZGF = Flange as accessory e.g. for NRE	A = Flat Face (A) T = Raised Face (B1) C = Tongue (C) D = Groove (D)	1 = DIN / Carbon steel / EN 1092 B1 2 = DIN / Stainless steel / EN 1092 B1 3 = DIN / Polypropylene / EN 1092 A 5 = ANSI / Carbon Steel / ASME B16.5 RF 6 = ANSI / Stainless steel / ASME B16.5 RF 7 = ANSI / PP / ASME B16.5 FF

Dimension DIN / ANSI	Pressure DIN / ANSI	Instrument side connection
D = DN15 / ½" A = DN20 / ¾" B = DN25 / 1" C = DN32 / 1¼" 7 = DN40 / 1½" 0 = DN50 / 2" 1 = DN65 / 2½" 2 = DN80 / 3" 3 = DN100 / 4" 4 = DN125 / 5" 5 = DN150 / 6" 6 = DN200 / 8" 8 = DN250 / 10" 9 = DN300 / 12"	1 = PN16 / 150 psi 2 = PN25 / 300 psi 3 = PN40 / 600 psi 4 = PN63 / 900 psi	1 = ¼" BSP C = ½" BSP D = ½" NPT E = ¾" BSP 4 = ¾" NPT 2 = 1" BSP 5 = 1" NPT 7 = 1½" BSP 8 = 1½" NPT 3 = 2" BSP 6 = 2" NPT 9 = M20x1.5 H = Weldable to NVI (stainless steel only) J = Weldable to NGS (stainless steel only) L = Weldable to NRM-4/ NRE-4 (stainless steel only)



Order Details ZPF (Example: ZPF-23)

Model	Standard / Flange Material / Form	Flange type
<p>ZPF = Flange made from PP as accessory e.g. for NRE</p>	<p>DIN Flanges PN16</p> <p>2 = DN80 PN16 3 = DN100 PN16 4 = DN125 PN16 5 = DN150 PN16 6 = DN200 PN16 7 = DN250 PN16 8 = DN300 PN16 9 = DN350 PN16</p> <p>FF ANSI flanges, 150 psi</p> <p>A = 3" FF 150 psi B = 4" FF 150 psi C = 5" FF 150 psi D = 6" FF 150 psi E = 8" FF 150 psi Y = 12" FF 150 psi K = 14" FF 150 psi</p>	<p>3 = For units with 2" BSP process connection 4 = For units with 2" NPT process connection 6 = For units with 1½" BSP process connection 7 = For units with 1½" NPT process connection</p>

Wiring

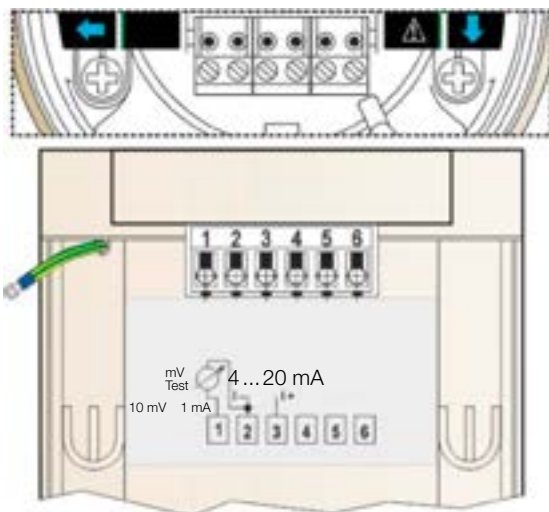

Designing a measuring network in a non-explosive environment

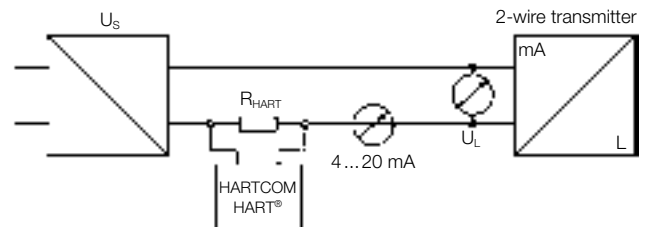

Power supply

Nominal voltage: 24 V_{DC}
 Maximum voltage (U_{in}): 36 V_{DC}
 Minimum voltage (U_{in}): Depends on the load impedance.
 (See diagram)

Loop resistance, R_{loop}: R_{HART} + R_{cable} + R_{ammeter}

Minimum R_A: 0 Ω

Maximum R_A: 750 Ω

R_{HART} resistance for HART® communication: 250 Ω (recommended)

Designing a measuring network in a non-explosive environment (cont'd)

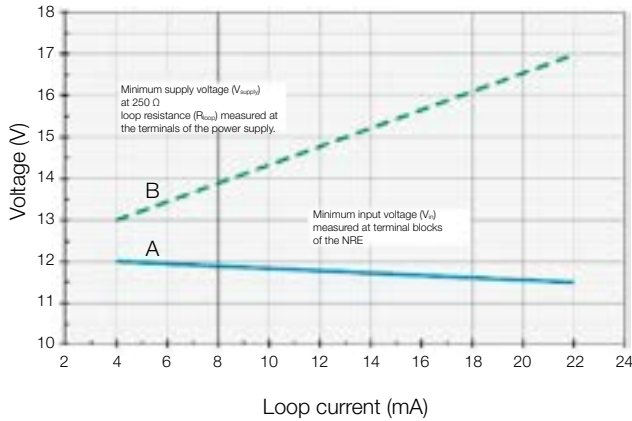

Line "A": minimum voltage at the input terminals of the device
 Line "B": minimum supply voltage (voltage across the device and the 250 Ω loop resistor)

Example for calculating the supply voltage:

The required minimum supply voltage at $I_{min} = 4 \text{ mA}$:
 $U_{supply \text{ min.}} = U_{input \text{ min.}} + (I_{min} * \text{loop resistance}) = 11.5 \text{ V} + (4 \text{ mA} * 0.25 \text{ k}\Omega) = 12.5 \text{ V}$
 The required minimum supply voltage at $I_{max} = 22 \text{ mA}$:
 $U_{supply \text{ min.}} = U_{input \text{ min.}} + (I_{min} * \text{loop resistance}) = 11.5 \text{ V} + (22 \text{ mA} * 0.25 \text{ k}\Omega) = 18.5 \text{ V}$
 Therefore, in the case of a loop resistance of 250 Ω, the 17 V supply voltage is just sufficient for the whole 4...20 mA in the measurement range.

HART® communication

The output of the device can be used as:

- n Current loop output and HART®

The NUS-NTB-NRM-SW program supports the current output mode with HART®. In accordance with the Rosemount Standard, HART® communication can be used between the NRE as a "slave" and the HART® master as a point-to-point connection.

Communication can be implemented as follows:

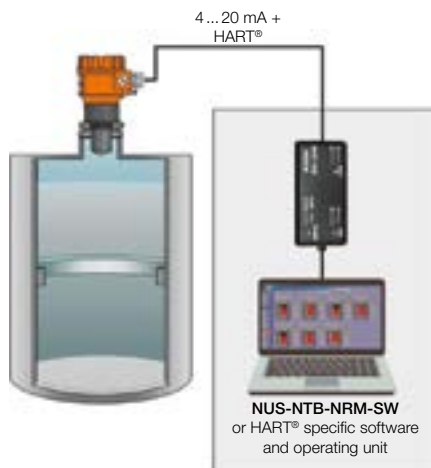

Display NRM-300P

The NRM-300P is a 64x128 dot-matrix LCD display which can be plugged into the transmitter (only available for NRE-4).

Warning! The NRM-300P module is based on LCD technology, so please make sure it is not exposed to permanent heat or direct sunlight, in order to avoid damage of the display unit.

If the instrument cannot be protected against direct sunlight or high temperature that is beyond the standard operating temperature range of the NRM-300P, please do not leave the NRM-300P display in the instrument.

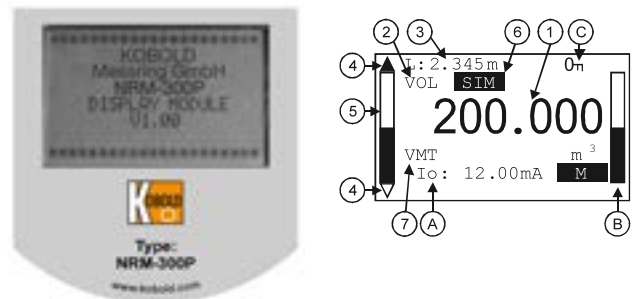

Measurement displaying with the NRM-300P display unit

Elements of the displaying:

1. Primary (Measured) Value (PV), in accordance to BASIC SETUP/PV. MODE.
2. Calculation mode of Primary Value (PV), in accordance to BASIC SETUP/PV. MODE.
3. Type and value of the initial quantity used for calculating the Primary Value (PV):
 - in case of Level measurement (LEV) it is Distance (DIST),
 - in case of Volume measurement (VOL) it is Level (LEV).
4. Trend direction arrows. The empty triangle shows when the change of the measured value is small, the filled triangle shows large-scale change. If none of the arrows are shown the measured value is constant.
5. Measured PV (Distance Value) in relation to measurement range (Sensor range) displayed in a bargraph.
6. Indication of Primary Value simulation. In this case the display and output show the values of the simulation and not the measured values.
7. Indication of active (Volume/Mass Table - VMT) calculation mode.

During active simulation the critical measurement errors will be displayed to give information to the user.

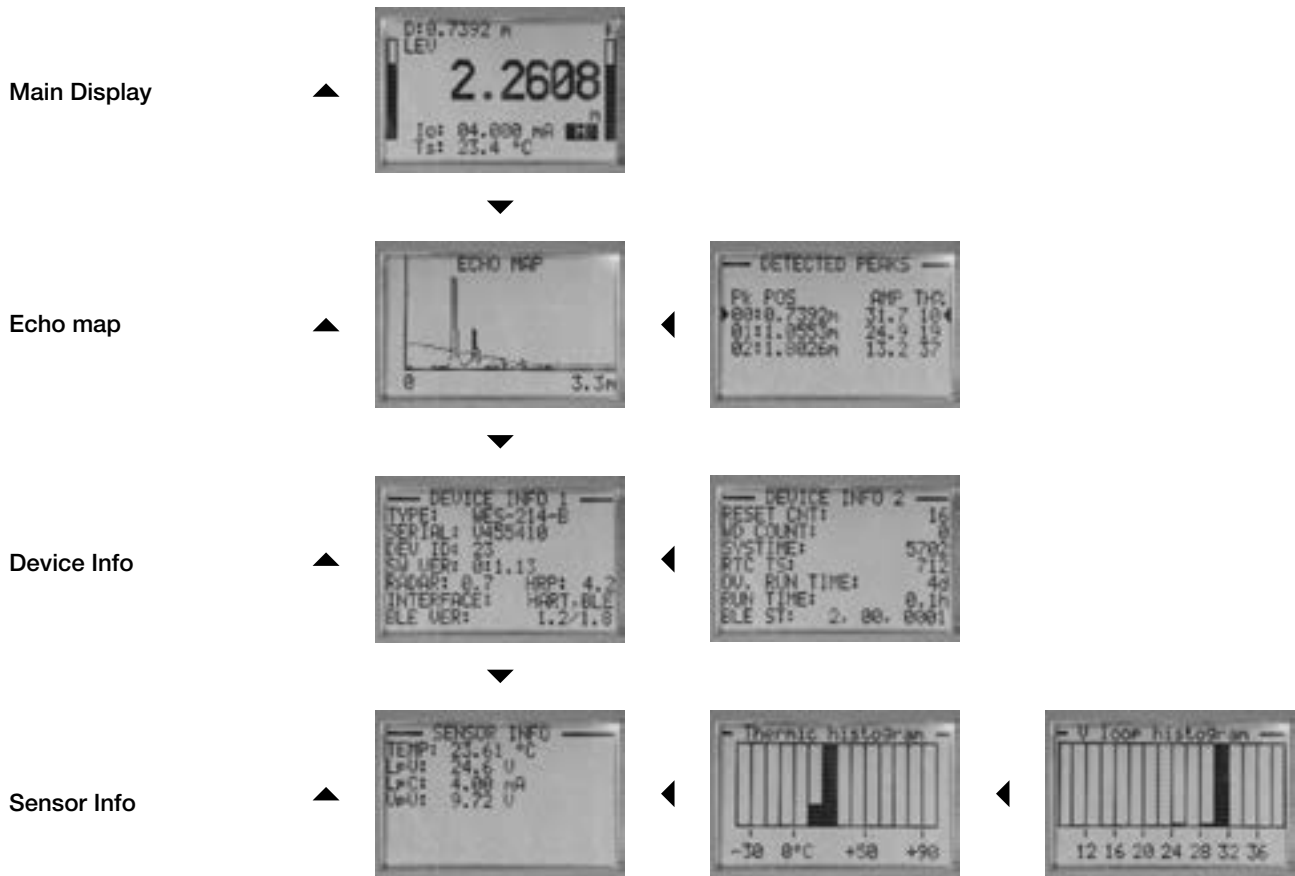

Echo map

- Graphical echo diagram: the dashed line indicates the current threshold setting.
- Table of detected peaks: the selected peak is indicated by the arrows at the end of the row.

Device Info 1

- Device type
- Device serial number
- HART device ID
- Main software version
- Radar and HRP software version
- Interfaces
- BLE version, hardware/software

Device Info 2

- Number of switch-ons
- Number of watchdog events
- Current system time [1/8 sec]
- RTC system time [1 sec]
- Total operating time [hours] (after 24 hours, the value is displayed in days.)
- Time elapsed since last power-on [hours]
- BLE status (status, reason for disconnection, reason for last reset)

Sensor Info

- Device electronics temperature
- Terminal voltage
- Loop current (calculated)
- Internal buffer voltage

Temperature histogram

Terminal voltage histogram



Dimensions [mm]

NRE-41xPR25...
NRE-41xPN25...

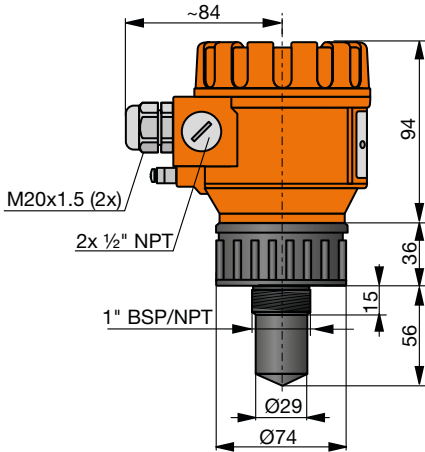

NRE-4xxPR40...
NRE-4xxPN40...

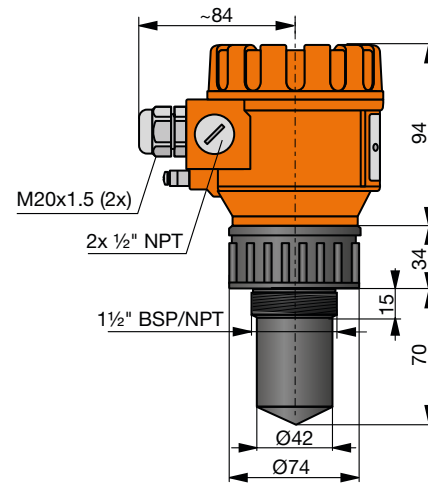

NRE-41xMR25...
NRE-41xMN25

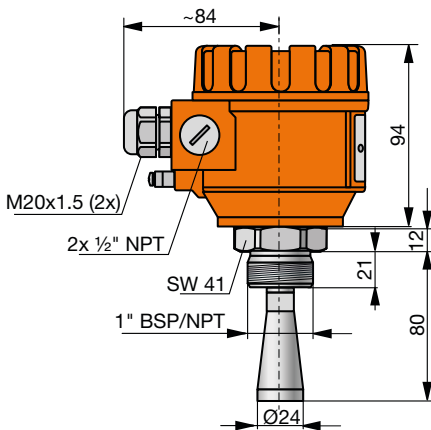

NRE-4xxMR40
NRE-4xxMN40

