

Differential Pressure Switch for Low Pressure HVAC Applications



measuring
•
monitoring
•
analyzing

SCH-PSB



- Setting Range: 20... 300 to 200... 1000 Pascal
(0.0029...0.0435 to 0.0290...0.1450 PSI)
(0.0803...1.2049 to 0.8033...4.0165 Inches W.C.)
- p_{\max} : 10 kPa (1.45 PSI)
- t_{\max} : 158 °F
- Process Connection: Hose Barbs



Order from: **C A Briggs Company**
622 Mary Street; Suite 101; Warminster, PA 18974
Phone: 267-673-8117 - Fax: 267-673-8118
Sales@cabriggs.com - www.cabriggs.com

KOBOLD Instruments, Inc.
1801 Parkway View Drive
Pittsburgh, PA 15205



Differential Pressure Switch Model SCH-PSB

Description

The KOBOLD SCH-PSB is an adjustable differential pressure switch for monitoring overpressure, vacuum, and differential pressure of air or other non-combustible, non-aggressive gases commonly found in HVAC applications. The switching pressure may be adjusted without a pressure gauge using a scaled adjustment knob. The switching differential is easily adjusted with a screwdriver.

Applications

- Monitoring Air Filters and Ventilators
- Monitoring Industrial Cooling-Air Circuits
- Overheating Protection for Fan Heaters
- Monitoring Flows in Ventilation Ducts
- Controlling Air and Fire-Protection Flaps
- Frost Protection for Heat Exchangers

Switching Pressure*

Model	Adjustment Range for Upper Switching Pressure (Pascal)	Switching Differential Set to: (Pascal)	Tolerance for Upper and Lower Switching Pressure
SCH-PSB-0300	20...300	10	±15%
SCH-PSB-0500	50...500	20	±15%
SCH-PSB-1000	200...1000	100	±15%

*Above specifications apply to vertical installation only, the recommended position with hose connections pointing downwards. If switches are installed horizontally, the switching values will be approximately 20 Pa (0.0029 PSI) higher.

Technical Details

- Max. Pressure:** 10 kPa (1.45 PSI) for All Ranges
- Media:** Air, Non-combustible and Non-aggressive Gases
- Media and Ambient Temperature:** -4...158 °F
- Storage Temperature:** -40...158 °F
- Diaphragm Material:** Silicone, Tempered, Annealed, Free of Gas Emissions
- Pressure Connections:** 2 Hose Barbs
External Diameter 0.24":
- P1 = Connection to High Pressure Port (Marked +)
 - P2 = Connection to Low Pressure Port (Marked -)

Housing Materials

- Switch Body:** PA 6.6
- Cover:** PS
- Weight:** 0.33 lb
- Mech. Working Life:** Over 1 Million Switching Operations
- Electrical Rating:** Max. 1.0 A (0.4 A) / 250 V_{AC}
- Electrical Connections:** AMP Flat Plug 6.3x0.8 mm Acc. to DIN 46244 or Push-on Screw Terminals. Cable Conduit w/Cable Strain Relief.
- Cable Entry:** Cap Nut Conduit AF20
- Switch Mounting:** Mounting Lugs

Contact Arrangement:

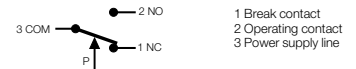

Ingress Protection: IP 54

Conversion Table for SCH-PSB Ranges

Pascal	PSI	Inches W.C.
20 ... 300	0.0029...0.0435	0.0803...1.2049
50 ... 500	0.0073...0.0725	0.2022...2.0082
200 ... 1000	0.0290...0.1450	0.8033...4.0165

Dimensions

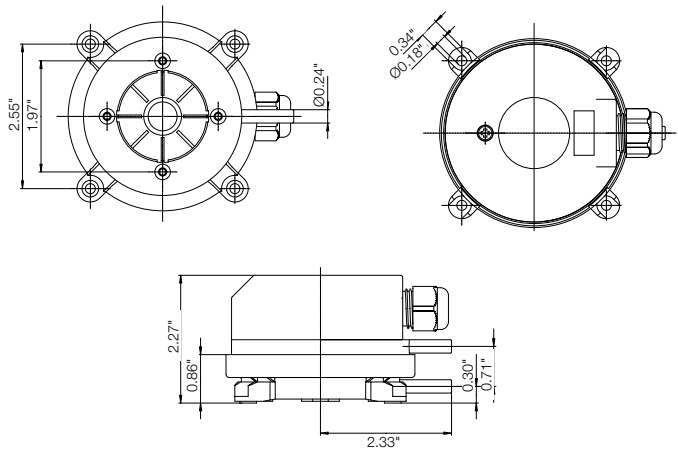

Order Details (Example: SCH-PSB-0300)

Model	Pressure Ranges (Pascal)
SCH-PSB-..0300	= 20 ... 300
SCH-PSB-..0500	= 50 ... 500
SCH-PSB-..1000	= 200... 1000

Included with all models: 2 m PVC hose and 2 ABS plastic tubes