

Heavy Duty Differential Pressure Transmitter



measuring
•
monitoring
•
analyzing

PAD



- Span: 0.3" W.C. ... 6" W.C. to 60 ... 6000 PSIG
- Static Pressure: Max. 4500 PSIG
- t_{max} : 248 °F
- Process Connection: 1/2" NPT, 1/4" NPT, or Various Diaphragm Seals Available upon Request
- Material: Stainless Steel
- Various Outputs: 4 ... 20 mA or Frequency Output
- Sensor Inputs: Differential, Gauge, or Absolute Pressure
- Digital Communication with HART® Protocol



Order from: **C A Briggs Company**
622 Mary Street; Suite 101; Warminster, PA 18974
Phone: 267-673-8117 - Fax: 267-673-8118
Sales@cabriggs.com - www.cabriggs.com

KOBOLD Instruments, Inc.
1801 Parkway View Drive
Pittsburgh, PA 15205



Heavy Duty Differential Pressure Transmitter Model PAD



Features

Superior Performance

- High Reference Accuracy
- Long-term Stability (0.125 % URL for 3 Years)
- High Rangeability (100:1) for Range 4-0

Flexibility

- Data Configuration with HART® Communicator
- Zero Point Adjustment

Reliability

- Continuous Self-diagnostic Function
- Automatic Ambient Temperature Compensation
- EEPROM Write Protection
- Fail-mode Process Function
- CE EMC Conformity Standards (EN 50081-2, EN 50082-2)

Description

The KOBOLD Differential Pressure Transmitter model PAD is a microprocessor based high performance transmitter. It has flexible pressure calibration and output, automatic compensation of ambient temperature and process variables, configuration of various parameters, and communication with HART® protocol. It measures pressure, flow and level by an application method. All data is input, modified and stored in EEPROM.

The KOBOLD Pressure Transmitter is also available as a flow meter. The flowmeter model PAD-F has an added totalizing function. It is able to check the flow rate and the totalizing flow. It measures the flow rate by using differential pressure without compensation for the temperature and static pressure. The shape of the PAD-F is the same as the standard device. Only the terminal block is different, since there are two more terminals for the display of the pulse output.

Transmitter Description

Electronics module

The Electronics module consists of a circuit board sealed in an enclosure. There is an MCU module, an analog module, an LCD module and a terminal module within the transmitter. The MCU module acquires the digital value from the analog module and applies correction coefficients selected from EEPROM. The output section of the MCU module converts the digital signal to a 4...20 mA output. The MCU module communicates with the HART®-based communicator or control system such as DCS. The power section of the MCU module has a DC-to-DC power conversion circuit and an input/output isolation circuit. The LCD module plugs into the MCU module and displays the digital output in a user-configured unit.

Functional Block Diagram

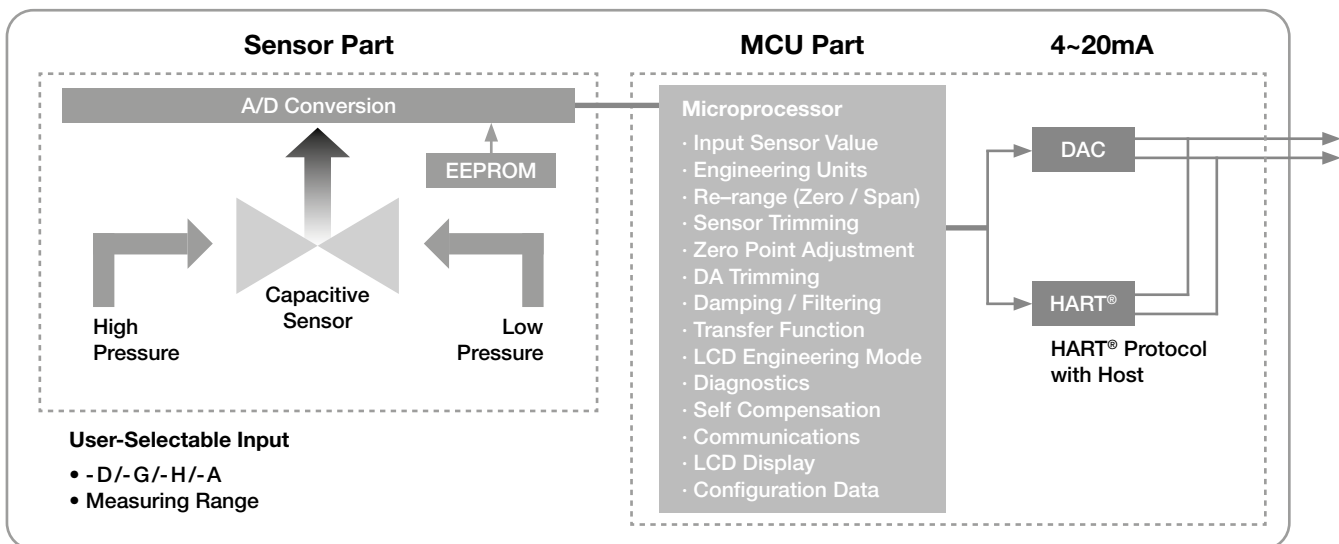

Sensor Inputs

The models PAD-D, PAD-G, and PAD-H are available in a capacitance type differential pressure sensor. It measures differential and gauge pressure and is commonly used in flow and level applications. Both sides in the capacitance sensor transmit process pressure from the process isolators to the sensor. The model PAD-A is also available in a piezoresistive type absolute pressure sensor. The sensor module converts the capacitance or the resistance to the digital value. The MCU module calculates the process pressure based on the digital value.

The sensor modules include the following features

- The software of the transmitter compensates thermal effects, improving performance.
- Precise Input Compensation during operation is achieved with temperature and pressure correction coefficients that are characterized over the range of the transmitter and stored in the sensor module EEPROM memory.
- EEPROM stores sensor information and correction coefficients separately from MCU module, allowing for easy repair, reconfiguration and replacement.

Basic Setups

The following settings can be easily configured from any host that supports the HART® protocol:

- Operational Parameters
- 4-20 mA Points (Zero/Span)
- Engineering Units
- Damping Time: 0.25...60 sec
- Tag: 8 Alphanumeric Characters
- Descriptor: 16 Characters
- Message: 32 Characters
- Date: Day/Month/Year

Calibration and Adjustment

- Lower/Upper Range (Zero/Span)
- Sensor Zero Trimming
- Zero Point Adjustment
- DAC Output Trimming
- Transfer Function
- Self-Compensation

Self-Diagnosis and others

- CPU & Analog Module Fault Detection
- Communication Error
- Fail-mode Handling
- LCD Indication
- Temperature Measurement of Sensor Module



Multi Planar Process Connection

When the pressure transmitter should be vertically installed irrespective of the orientation of the process connection lines, modified flanges (as shown above) are required in addition to the basic flanges. Multi-planar pressure transmitters have been made in an effort to solve the problems occurring in these types of installation. The object of this is to provide a pressure transmitter, capable of being vertically installed, without separate adapters or various types of brackets. This is regardless of the position of the process connection lines.

Process Connection Via Diaphragm Seals

When connecting the differential pressure transmitter model PAD to all different process connections, diverse diaphragm seal versions are necessary. They can be connected to the differential pressure transmitter by direct mounting or via a capillary tube. Depending on the application, different combinations of diaphragm seals, capillary tubes and fill fluids are available. To clarify those options, the special connections via diaphragm seals should be specified separately for the differential pressure transmitter.





Heavy Duty Differential Pressure Transmitter Model PAD

Technical Details

Measuring Principle: Capacitance Sensor (PAD-D, -F, -G, -H)
Piezo-resistive (PAD-A)

Measuring Span: 0.3" W.C..6" W.C. to 60...6,000 PSIG bar (Depending on Instrument Version)
Zero and Span Values can be set anywhere within the Range Limits.
Span must be Greater than or Equal to the Minimum Span.

Accuracy

Range 2: $\pm 0.25\%$ of Span for
 $0.1 \text{ URL} \leq \text{Span} \leq \text{URL}$
 $\pm [0.24 + (0.008 \times (\text{URL}/\text{Span}))\%]$ of Span for $0.05 \text{ URL} \leq \text{Span} \leq 0.1 \text{ URL}$

Range 3: $\pm 0.075\%$ of Span for
 $0.1 \text{ URL} \leq \text{Span} \leq \text{URL}$
 $\pm [0.25 + (0.005 \times (\text{URL}/\text{span}))\%]$ of Span for $0.02 \text{ URL} \leq \text{Span} \leq 0.1 \text{ URL}$

Range 4 to 0: $\pm 0.075\%$ of Span for
 $0.1 \text{ URL} \leq \text{Span} \leq \text{URL}$
 $\pm [0.025 + (0.005 \times (\text{URL}/\text{Span}))\%]$ of Span for $0.01 \text{ URL} \leq \text{Span} \leq 0.1 \text{ URL}$

Stability: $\pm 0.125\%$ URL for 36 Months

Static Press. Effect: $\pm 0.1\%$ URL per 70 bar (Zero Error)
 $\pm 0.2\%$ of Reading per 70 bar (Span Error)

Turndown Ratio: Ranges 4 ~ 0 = 100:1
Range 3 = 50:1
Range 2 = 20:1

Process Temp.: -40...248°F
(Approval Codes may Affect Limits.
Max. Ambient Temperature at LCD = 176°F)

Ambient Temp.: -22...176°F

Ambient Temp. Effect: $\pm (0.019\% \text{ URL} + 0.125\% \text{ Span}) / 28^\circ\text{C}$

Storage Temp.: -40...185°F (Non-condensing)

Humidity Limit: 5 %...100 % RH

Power Supply Effect: $\pm 0.005\%$ of span per Volt

Mounting Pos. Effect: Zero Shift up to 350 Pa, no span effect

Pressure Limits (with Silicone Oil)

(Valid for stand-alone instruments only without assembled diaphragm seals.)

Model D and G: 0...1999.6 PSIG (for Range 2...8)

Model G: 0...5800 PSIG (for Range 9)

0...10875 PSIG (for Range 0)

Model H: 0...4495 PSIG (for Range 4...7)

Model A: 0...72.5 PSIG (for Range 4)

0...435 PSIG (for Range 5)

0...754 PSIG (for Range 6)

Burst Pressure

Model D, G and H: 9990.5 PSIG
11600 PSIG (for Model G, Range 0)

Model A: 145 PSIG (for Range 4)
580 PSIG (for Range 5)
1015 PSIG (for Range 6)

Wetted Materials

Isolating Diaphragms: 316L SS

Drain/Vent Valves: 316 SS

Flanges/Adapters: 316 SS

O-ring: FKM, PTFE as an Option

Non-Wetted Materials

Fill Fluid: Silicone Oil

Bolts: Stainless Steel

Housing: Aluminum or SS, Flameproof (Ex d) and Waterproof (IP67)

Cover O-ring: NBR

Paint: Epoxy-polyester or Polyurethane

Mounting Bracket: For 2-inch Pipe, 304 SS, with 304 SS U-bolt

Nameplate: 304 SS

Process Connections

Connections: 1/4" NPT with 54.0 mm Center Distance for Standard Flanges, 1/2" NPT with Process Adapter (Option)

Mount Position: Upright (Process Connection more Flexible by using Multi-planar Flange)

Display: 5 Digit LCD

Power Supply: 12...45 V_{DC}
17.5...45 V_{DC} -HART® Communication

Maximum Load: 250 Ω at 17.5 V_{DC}
550 Ω at 24 V_{DC}

Max. Loop Resistance =

Loop Load: 0...1500 Ω - Operation $\frac{(U - 12 V_{DC})}{0.022 A}$
250...550 Ω - HART® Communication

Failure Mode: Fail High: Current $\geq 21.1 \text{ mA}$
Fail Low: Current $\leq 3.78 \text{ mA}$

Electrical Connection

Connection: 1/2" NPT Conduit with M4 Screw Terminals (G1/2 Option)

Output

- Two Wire 4...20 mA, Configurable for Linear or Square Root Output, Digital Process Value Superimposed on 4...20 mA Signal, Available to any Host that Conforms to the HART® Protocol

- Frequency Output for Flowmeter Model PAD-F with Pulse Width of 10, 50 or 100 ms (Selectable, Negative Going Pulse)
Output Type: Open Collector, 30 V, 500 mA max.
Pulse Rate: 49 pulses/sec max.

Response Time: 120...200 ms (within 10-90% of full scale)

Turn-On Time: 3 seconds

Protection: IP 67 for Standard (Code S)

Weight: 8.6 lb (Excluding Options) Standard
11.8 lb (SS Housing - Excl. Options)

ATEX Approval: II 2G Exd IIC T6... T5 (Option)

II 1G or 2G Ex ia IIC T5 or T4 Ga or Gb (Option)



Order Details (Example: **PAD-D EE 2 S 2 N S 0 0**)

Model	Version	Material Body/Vent Plug/ Diaphragm	Calibrated Span (Measuring Range Limits for PAD-D, -F, -G and -H in Separate Table)
PAD-	<p>..D.. = Differential Pressure Transmitter (Static Pressure 2000 PSI)</p> <p>..F..¹⁾ = Differential Pressure Transmitter with Pulse Output and Totalizer for Flow Measurement</p> <p>..H.. = Differential Pressure Transmitter for High Line Pressure (Static Pressure 4495 PSI)</p> <p>..G.. = Gauge Pressure Transmitter</p> <p>..A.. = Absolute Pressure Transmitter</p>	..EE.. = 316 SS / 316 SS / 316L SS	<p>Calibrated Span for PAD-D, -F, -G, -H</p> <p>..2..³⁾ = 0.3"...6" W.C.</p> <p>..3.. = 0.6"...30" W.C.</p> <p>..4.. = 1.5"...150" W.C.</p> <p>..5.. = 7.5"...750" W.C.</p> <p>..6.. = 1...100 PSIG</p> <p>..7.. = 3...300 PSIG</p> <p>..8..³⁾ = 10 ...1000 PSIG</p> <p>..9..³⁾⁴⁾ = 30...3000 PSIG</p> <p>..0..³⁾⁴⁾ = 60...6000 PSIG</p> <p>Calibrated Span for PAD-A</p> <p>..4.. = 10"...1000" W.C.</p> <p>..5.. = 1.5...217 PSIA</p> <p>..6.. = 3...362 PSIA</p>

Order Details Continued

Fill Liquid	Process Connection	Electrical Connection	Approvals	Options
..S.. = Silicone	..2..⁶⁾ = 1/4" NPT Female	<p>..N.. = 1/2" NPT Epoxy-Polyester Painted Aluminum</p> <p>..G.. =G 1/2 Epoxy-Polyester Painted Aluminum</p>	<p>..S0.. = Standard (Waterproof IP67)</p> <p>..F0.. = ATEX, Flameproof, Ex d</p> <p>..E0.. = ATEX, Intrinsically Safe, Ex i</p>	<p>..0 = without</p> <p>..C = Engineering Unit (must be chosen when using the differential transmitter as a flowmeter)</p> <p>..D = PTFE O-ring (Wetted Part)</p> <p>..E = Oil Free Finish</p> <p>..F = Side Vent / Drain Bottom</p> <p>..G = Side Vent / Drain Top</p> <p>..H = Multi-Planar Process Connection</p> <p>..M = Housing in Stainless Steel</p> <p>..N⁶⁾ = Mounting of PAD onto Diaphragm Seal</p>

¹⁾ Specify flow rate engineering unit, Δ p and flow rate at URV (Upper Range Value), Δ p and flow rate (generally '0') at LRV (Lower Range Value) pulse scale (choose only one value from 0.001, 0.01, 0.1, 1, 10, 100, 1000, 10000 m³/pulse) and pulse width (choose only one value from 10 ms, 50 ms, 100 ms), while ordering so that max. duty cycle is 49 pulses/sec

³⁾ Not for PAD-H
⁴⁾ Not for PAD-D and PAD-F
⁵⁾ Diaphragm seal model and application data to be specified in clear text. The online application guide on the PAD product page of the website must be completed for any PAD ordered with a DRM. For summary of diaphragm seal models and possible ranges, see page 17 onwards. For dimensional details see DRM data sheet.
⁶⁾ 1/2" NPT connection via an adapter is available, see page 6



Heavy Duty Differential Pressure Transmitter Model PAD

Order Details: Oval Flange Adapter

Description	Order Number
1/2" NPT Oval Flange Adapter	ZUB-PAD-OVF



Dimensions

Technical Details

Material: 316 Stainless Steel

Seal: PTFE

Bolts: 2 x Mounting Screws 7/16"-20 UNF

Connection: 1/2" NPT Female

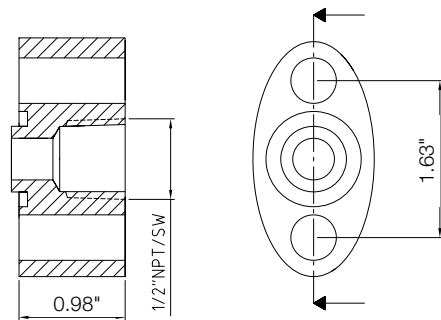

Order Details: Mounting Brackets

Description	Order Number
Angle Type Bracket for PAD/PAS Vertical Pipe Mounting for PAS Vertical Pipe Mounting for PAD Incl. U-Clamp for 2" Pipe Mounting Bracket and 2 x Mounting Nuts/Washers Incl. 4 x Mounting Screws for PAS Incl. 4 x Mounting Screws for PAD	ZUB-PAD/PAS-K
Flat Type Bracket for PAD/PAS Horizontal Pipe Mounting for PAS Vertical Pipe Mounting for PAD Incl. U-Clamp for 2" Pipe Mounting Bracket and Mounting Nuts/Washers Incl. 4 x Mounting Bolts and Washers for PAS Incl. 4 x Mounting Bolts for PAD	ZUB-PAD/PAS-L

Order Details: Manifold Valves

Description	Order Number
5-way Manifold Valve, Remote Mount, Machined	ZUB-PAD-5WMR
2-way Compact Manifold Valve, Direct Mount, Machined	V-2003CDADABAA
3-way Compact Manifold Valve, Direct Mount, Machined	V-3151CHHHIBAA
5-way Compact Manifold Valve, Direct Mount, Machined	V-5050CDAHIBAA



Measuring Range Limits for PAD-D, -F, -G and -H

Range Code	Calibrated Span	Lower Range Limit (LRL)			Upper Range Limit (URL)
		PAD-D, -F	PAD-G	PAD-H	
2	0.3...6" W.C.	-6" W.C.	-6" W.C.	-	6" W.C.
3	0.6...30" W.C.	-30" W.C.	-30" W.C.	-	30" W.C.
4	1.5...150" W.C.	-150" W.C.	-150" W.C.	-150" W.C.	150" W.C.
5	7.5...750" W.C.	-750" W.C.	-14.5 PSIG	-750" W.C.	750" W.C.
6	1...100 PSIG	-100 PSIG	-14.5 PSIG	-100 PSIG	100 PSIG
7	3...300 PSIG	-300 PSIG	-14.5 PSIG	-300 PSIG	300 PSIG
8	10...1000 PSIG	-1000 PSIG	-14.5 PSIG	-	1000 PSIG
9	30...3000 PSIG	-	-14.5 PSIG	-	3000 PSIG
0	60...6000 PSIG	-	-14.5 PSIG	-	6000 PSIG

* Special measuring span, with adequate lower and upper range limits, on request.

Range Code Unit Conversion

Range Code	bar	kg/cm ²	KPa	psi	in H ₂ O at 39°F	mm H ₂ O at 39°F	in Hg at 32°F
2	0.015	0.015	1.5	0.217	6	152	0.422
3	0.075	0.076	7.5	1.087	30	765	2.215
4	0.373	0.38	37.3	5.410	149	3804	11.014
5	1.865	1.902	186.5	27	749	19018	55.072
6	6.900	7.036	690	100	2773	70361	203.750
7	20.681	21.088	2068	300	8310	210878	610.660
8	68.950	70.309	6895	1000	27708	703097	2036.025
9	206.800	210.876	20680	3000	83105	2108781	6106.597
0	413.700	421.856	41370	6000	166085	4218566	12216.550



Heavy Duty Differential Pressure Transmitter Model PAD

Dimensions

PAD Standard*

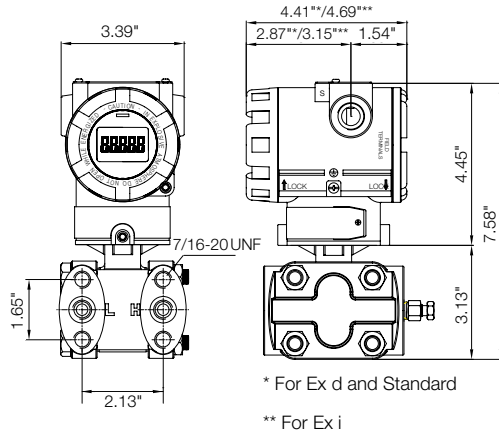

PAD Multi-Planar Process Connection*

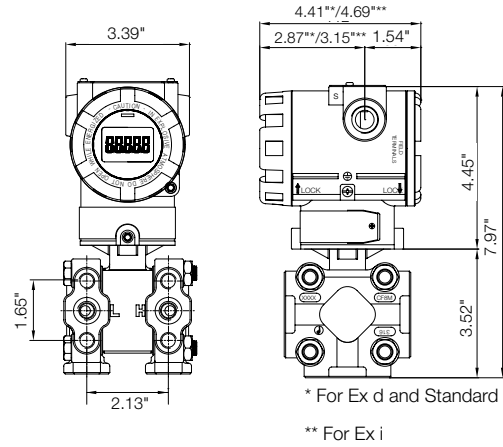

PAD with Multi-Planar Flange and Angle Type Bracket*

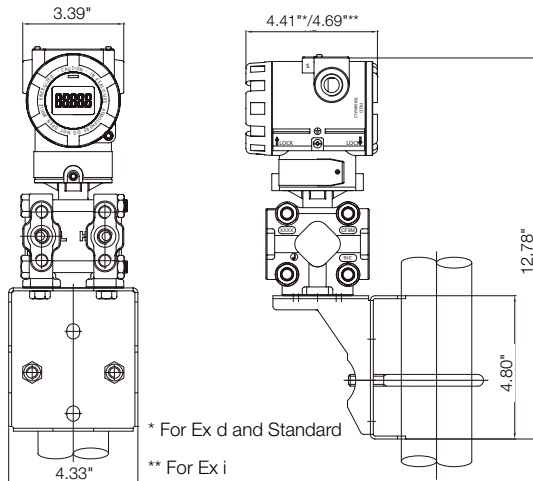

PAD Standard with Flat Type Bracket (Vertically Mounted)*

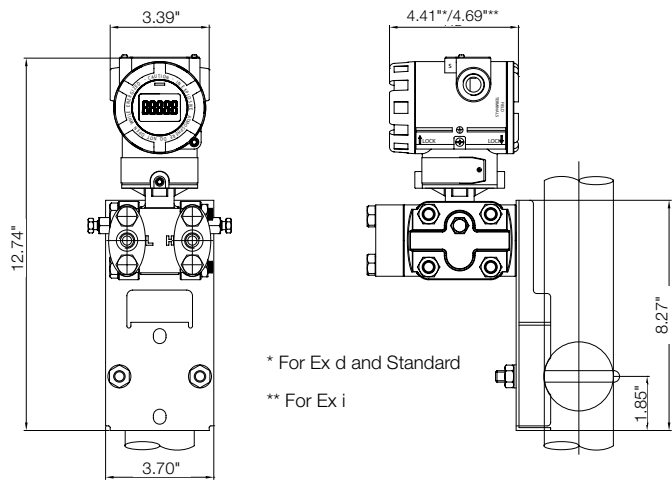

PAD Standard with Flat Type Bracket (Horizontally Mounted)*

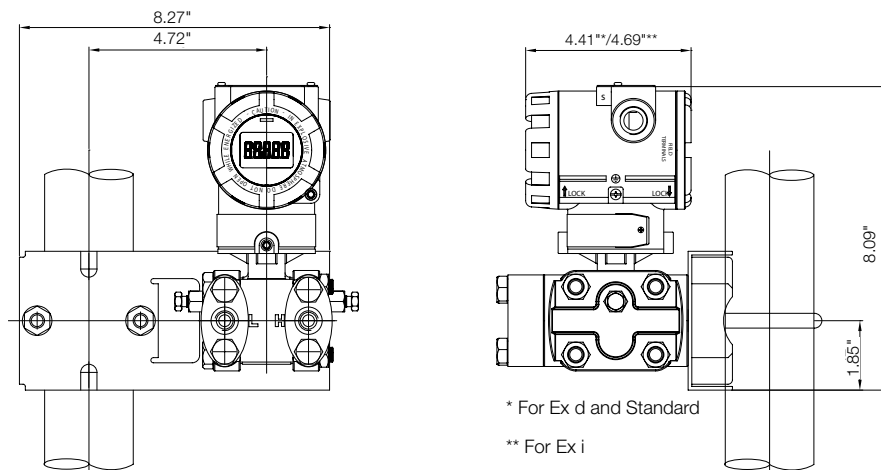

* For PAD-G/A, the low pressure port 'L' is always closed



PAD-G/A Mounted with 2-way Manifold Valve*

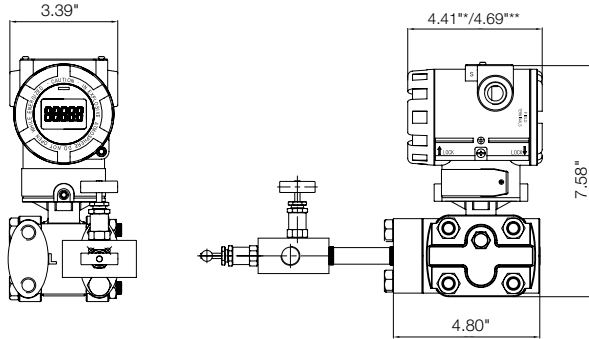

* For Ex d and Standard

** For Ex i

* For PAD-G/A, the low pressure port 'L' is always closed.

Manifold Valves (Remotely Mounted)

Technical Specifications

- Material:** 316 SS Body with PTFE Packing
- Connection:** 1/2" NPT (F)
- Pressure Rating:** 6000 PSIG at 100 °F (~410 bar)
- Temperature Range:** -65...449 °F

5-way Manifold Valve

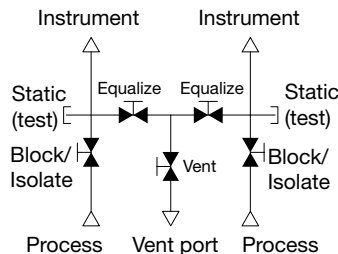
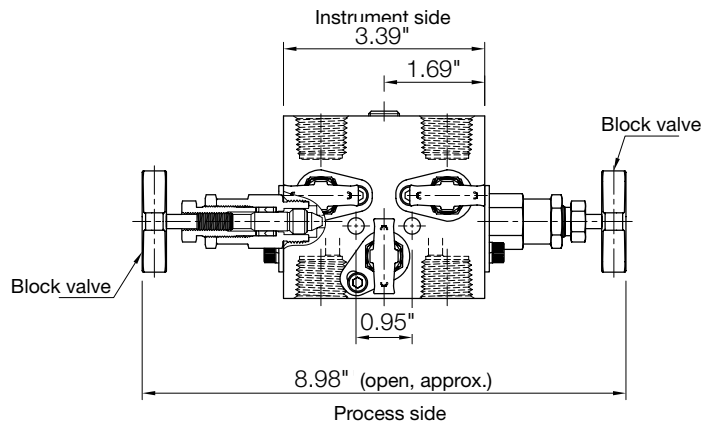
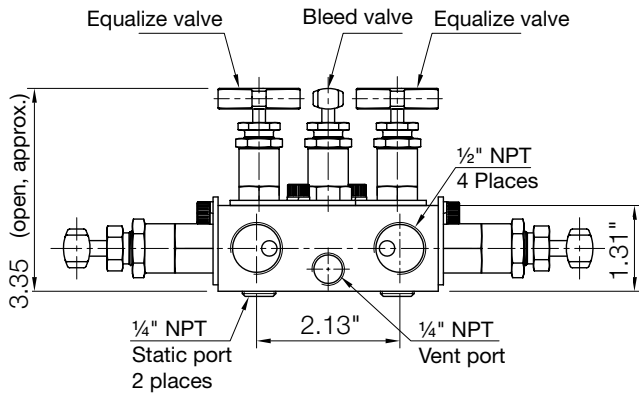

Weight: 4.85 lbs



Heavy Duty Differential Pressure Transmitter Model PAD

Manifold Valves (Direct Mount, Machined)

Technical Details

Material: AISI 316L
Pressure Rating: 6000 psi
Temperature Range: -99...410 °F (PTFE Packing), Standard
-65...950 °F (GRAPHOIL Packing), On Request
Weight: 1.94 lbs

2-way Manifold Valve: V-2003CDADABAA (PTFE Packing)
(Inlet: 1/2" NPT Female/Outlet: 1/2" NPT Male)

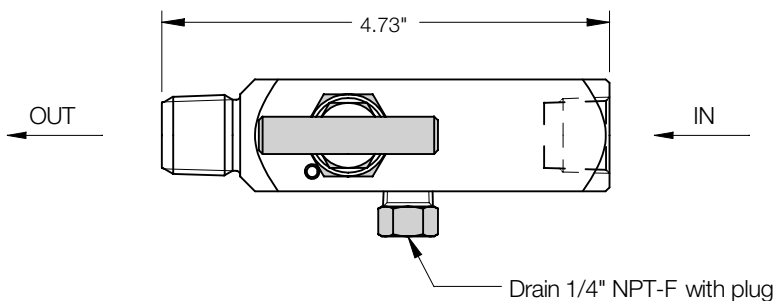
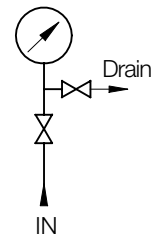
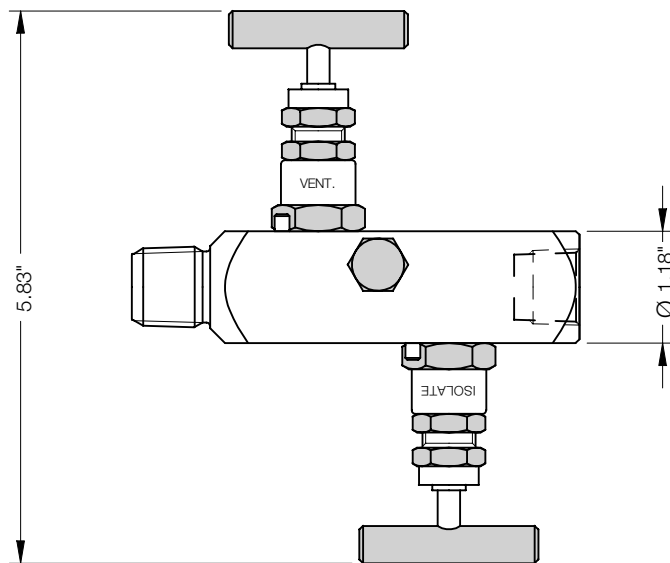

Included Accessories: Plug

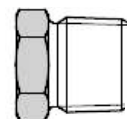

Manifold Valves (Direct Mount, Machined)

Technical Details

Material: AISI 316L
Pressure Rating: 6000 psi
Temperature Range: -99...410 °F (PTFE Packing), Standard
 -65...950 °F (GRAPHOIL Packing), On Request
Weight: 4.78 lbs



3-way Manifold Valve: V-3151CHHHIBAA (PTFE Packing)
 (Inlet: Flanged/Outlet: Flanged According to IEC 61518 Type B / Type A)

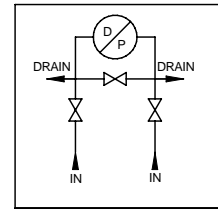
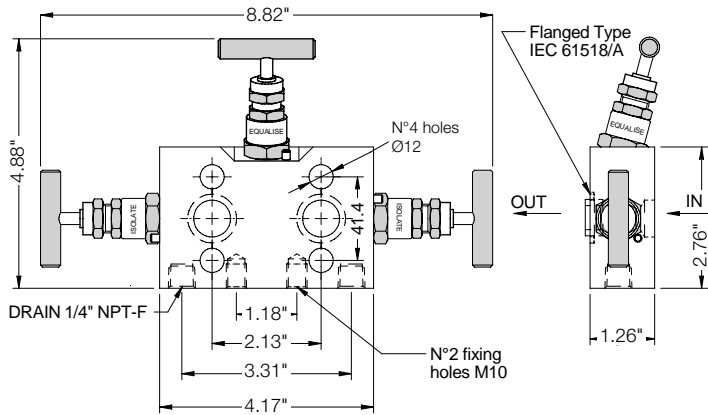

Included Accessories:

- 4 Carbon Steel Screws (Stainless Steel On Request)
- 2 Plugs
- 2 PTFE Gaskets



Mounting Options 3-way Manifold Valve with PAD

Description	Process Connection	Illustration
Valve Mounted Upside Down on Front Side of PAD	Flanged According to IEC 61518 Type A	
Valve Mounted Upside Down on Front Side of PAD including Oval Flange Adapter Model ZUB-PAD-OVF	1/2" NPT Female	
Valve Mounted on Front Side of PAD, Head of PAD Rotated 90° Clockwise	Flanged According to IEC 61518 Type A	
Valve Mounted on Front Side of PAD including Oval Flange Adapter Model ZUB-PAD-OVF, Head of PAD Rotated 90° Clockwise	1/2" NPT Female	



Heavy Duty Differential Pressure Transmitter Model PAD

Manifold Valves (Direct Mount, Machined)

Technical Details

Material: AISI 316L
Pressure Rating: 6000 psi
Temperature Range: -99...410 °F (PTFE Packing), Standard
 -65...950 °F (GRAPHOIL Packing), On Request
Weight: 6.17 lbs

5-way Manifold valve: V-5050CDAHIBAA (PTFE Packing)
 (Inlet: 1/2" NPT/Outlet: Flanged According to IEC 61518 Type A)

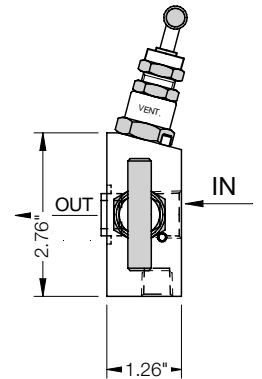
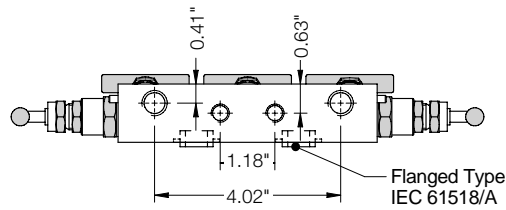
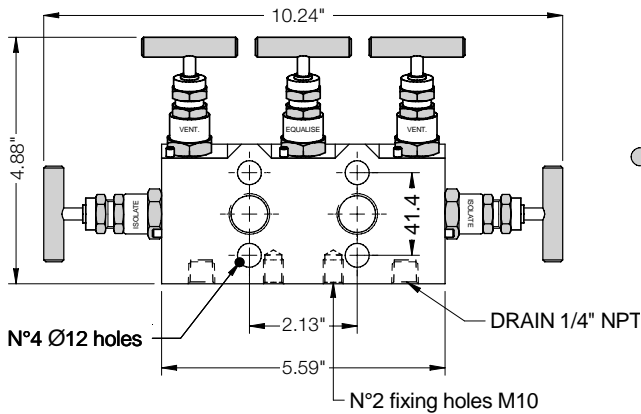
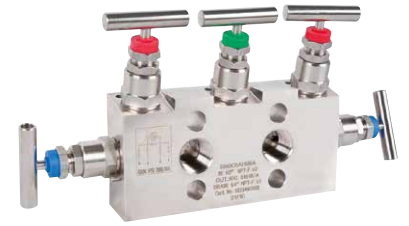
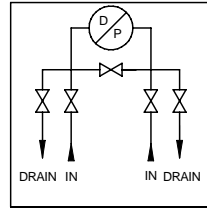

Included Accessories:

4 Carbon Steel Screws (Stainless Steel On Request)
 2 Plugs
 2 PTFE Gaskets

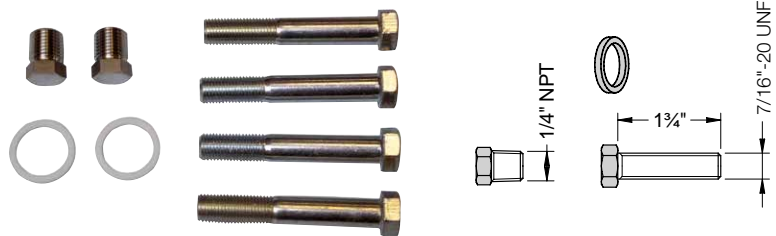

Mounting Options for 5-way Manifold Valve with PAD

Description	Process Connection	Illustration
Valve Mounted Upside Down on Front Side of PAD	1/2" NPT Female	
Valve Mounted on Front Side of PAD after Rotating the Head of PAD 90° Clockwise	1/2" NPT Female	



Manifold Valves (Direct Mount, Forged)

Technical Details

Material: 316L Stainless Steel
Pressure Rating: 6000 psi
Temperature Range: -99...410 °F (PTFE Packing), Standard
 -65...950 °F (GRAPHOIL Packing), On Request

Weight: 4.96 lbs

3-way Manifold Valve: V-3454CHHHHBAA (PTFE Packing)
 (Inlet: Flanged Oval/Outlet: Flanged According to IEC 61518 Type B)

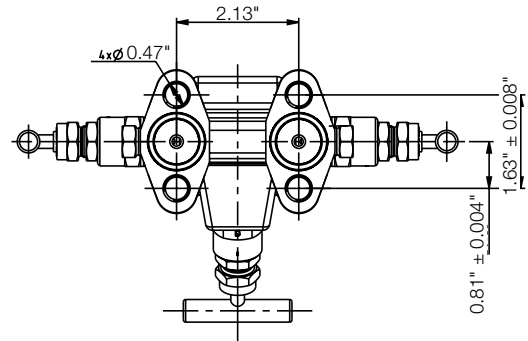
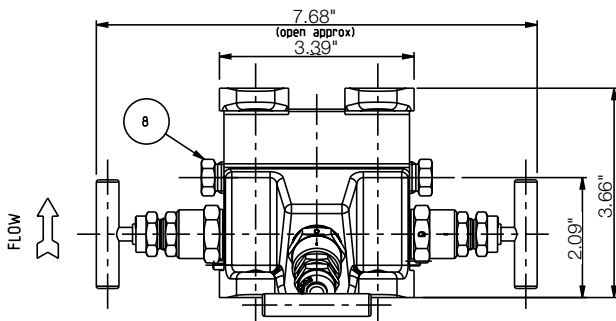
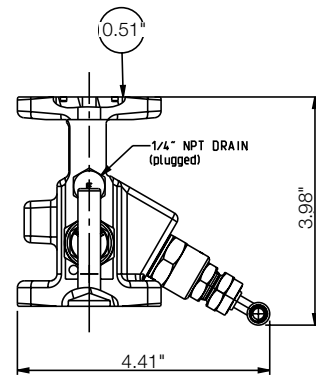
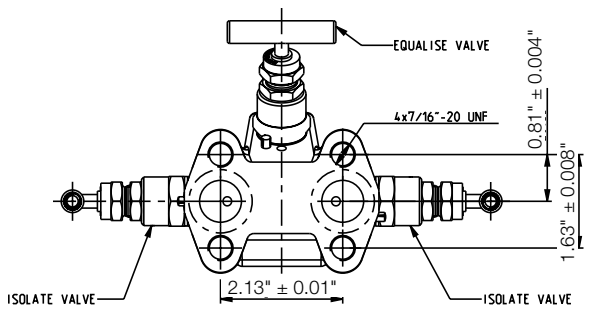

Included Accessories:

4 Carbon Steel Screws (Stainless Steel On Request)
 2 PTFE Gaskets





Heavy Duty Differential Pressure Transmitter Model PAD

Example of PAD Direct Assembled with an Extended Diaphragm Seal (not available as ATEX-Version)
 (for Dimensional Details, see DRM Data Sheet)

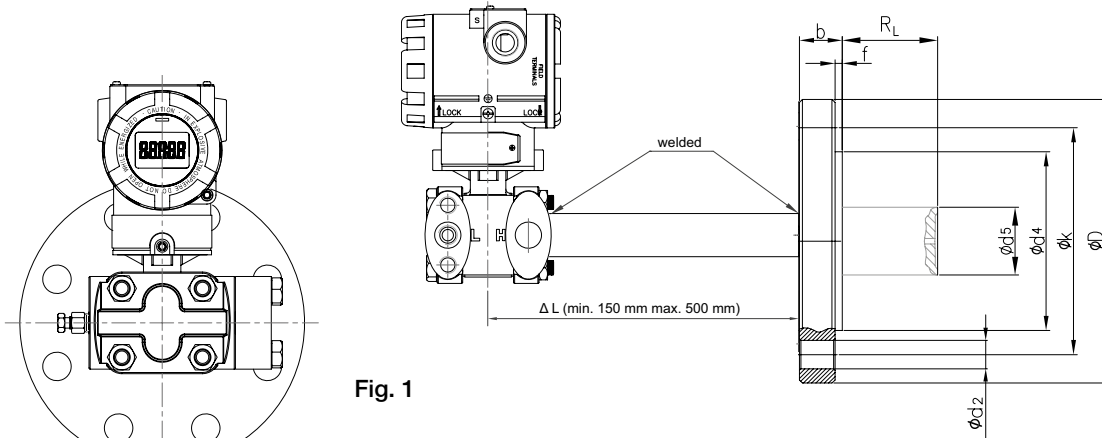

Fig. 1

Dimensions: Examples for DN50/DN80/DN100/2" ANSI/3" ANSI/4" ANSI

Flange Type	D	k	d ²	b	f	d ⁴	X	d ⁵	R _L
DN50 PN16	6.50"	4.92"	0.71"	0.71"	0.08"	4.02"	0.16"	1.89"	50 mm (2")/ 100 mm (4")/ 150 mm (6")/ 200 mm (8")/ (customer specified)
DN50 PN40	6.50"	4.92"	0.71"	0.79"	0.08"		0.16"	1.89"	
2" ANSI Cl. 150	6.00"	4.75"	0.75"	0.75"	0.08"	3.62"	0.16"	1.89"	
2" ANSI Cl. 300	6.50"	5.00"	0.75"	0.88"	0.08"		0.31"	1.89"	
DN80 PN16	7.87"	6.30"	0.71"	0.79"	0.08"	5.43"	0.31"	2.99"	
DN80 PN40	7.87"	6.30"	0.71"	0.94"	0.08"		0.31"	2.99"	
3" ANSI Cl. 150	7.50"	6.00"	0.75"	0.94"	0.06"	5.00"	0.16"	2.99"	
3" ANSI Cl. 300	8.25"	6.63"	0.87"	1.12"	0.06"		0.31"	2.99"	
DN100 PN16	8.66"	7.09"	0.71"	0.79"	0.08"	5.87"	0.31"	3.50"	
DN100 PN40	9.25"	7.48"	0.87"	0.94"	0.08"		5.87"	0.31"	
4" ANSI Cl. 150	9.00"	7.50"	0.75"	0.94"	0.06"	6.19"	0.31"	3.50"	
4" ANSI Cl. 300	10.00"	7.87"	0.87"	1.26"	0.06"		6.19"	0.31"	3.50"

Example of PAD Assembled with Remote Diaphragm Seals and Capillaries
 (for Dimensional Details, see DRM Data Sheet)

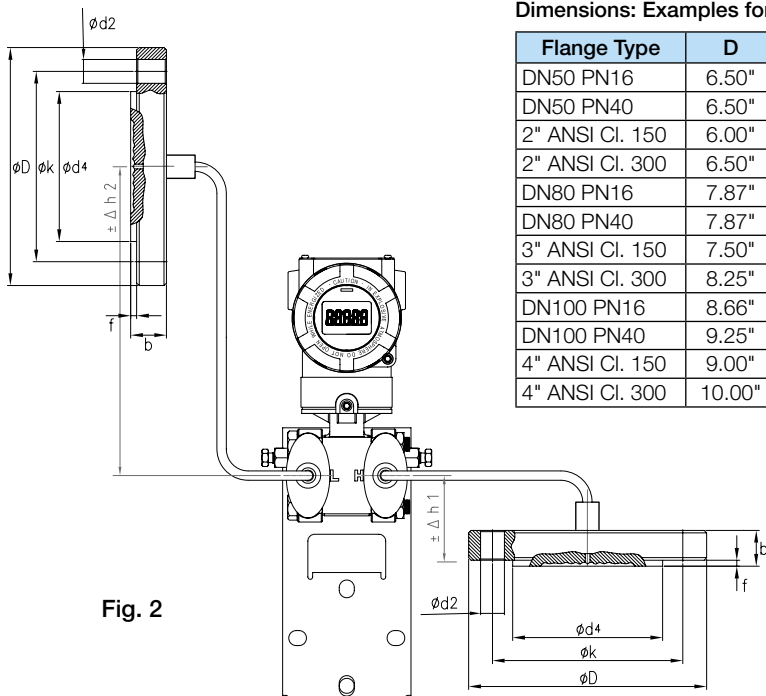
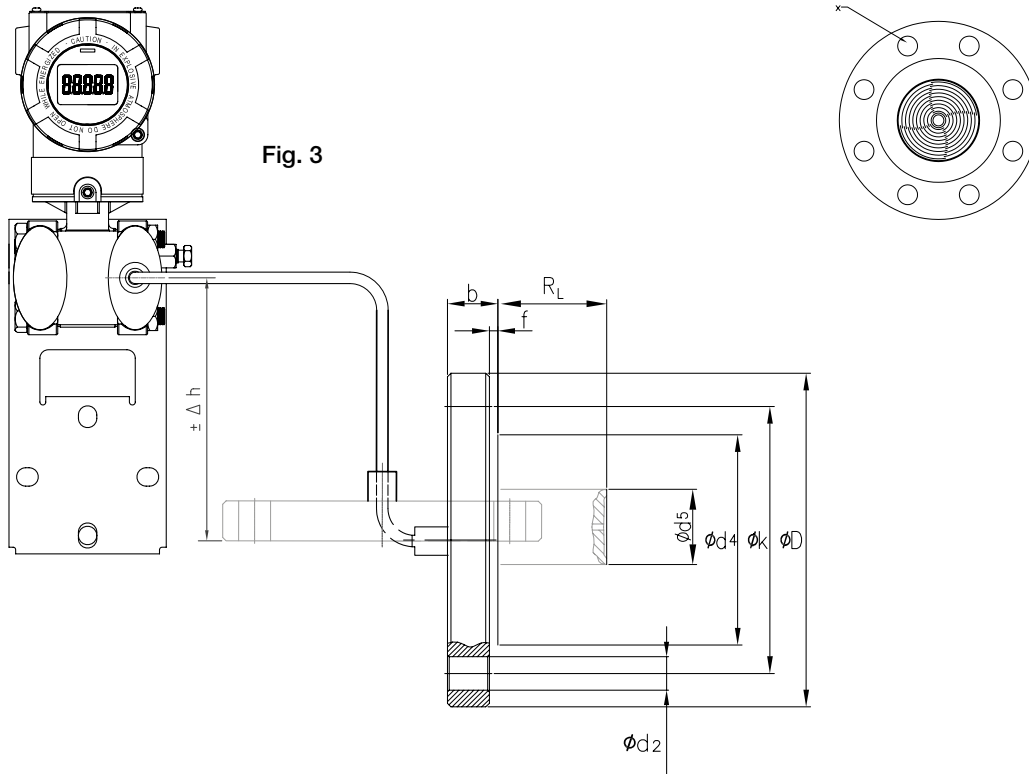

Fig. 2

Dimensions: Examples for DN50/DN80/DN100/2" ANSI/3" ANSI/4" ANSI

Flange Type	D	k	d ²	b	f	d ⁴	X
DN50 PN16	6.50"	4.92"	0.71"	0.71"	0.08"	4.02"	0.16"
DN50 PN40	6.50"	4.92"	0.71"	0.79"	0.08"		0.16"
2" ANSI Cl. 150	6.00"	4.75"	0.75"	0.75"	0.08"	3.62"	0.16"
2" ANSI Cl. 300	6.50"	5.00"	0.75"	0.88"	0.08"		0.31"
DN80 PN16	7.87"	6.30"	0.71"	0.79"	0.08"	5.43"	0.31"
DN80 PN40	7.87"	6.30"	0.71"	0.94"	0.08"		0.31"
3" ANSI Cl. 150	7.50"	6.00"	0.75"	0.94"	0.06"	5.00"	0.16"
3" ANSI Cl. 300	8.25"	6.63"	0.87"	1.12"	0.06"		0.31"
DN100 PN16	8.66"	7.09"	0.71"	0.79"	0.08"	5.87"	0.31"
DN100 PN40	9.25"	7.48"	0.87"	0.94"	0.08"		5.87"
4" ANSI Cl. 150	9.00"	7.50"	0.75"	0.94"	0.06"	6.19"	0.31"
4" ANSI Cl. 300	10.00"	7.87"	0.87"	1.26"	0.06"		6.19"

Example of PAD-G Remote Assembled with (Extended) Diaphragm Seal and Capillary
 (for Dimensional Details, see DRM Data Sheet)



Dimensions: Examples for DN50/DN 80/DN100/2" ANSI/3" ANSI/4" ANSI

Flange Type	D	k	d ²	b	f	d ⁴	X	d ⁵	R _L
DN50 PN16	6.50"	4.92"	0.71"	0.71"	0.08"	4.02"	0.16"	1.89"	50 mm (2")/ 100 mm (4")/ 150 mm (6")/ 200 mm (8")/ (customer specified)
DN50 PN40	6.50"	4.92"	0.71"	0.79"	0.08"		0.16"	1.89"	
2" ANSI Cl. 150	6.00"	4.75"	0.75"	0.75"	0.08"	3.62"	0.16"	1.89"	
2" ANSI Cl. 300	6.50"	5.00"	0.75"	0.88"	0.08"		0.31"	1.89"	
DN80 PN16	7.87"	6.30"	0.71"	0.79"	0.08"	5.43"	0.31"	2.99"	
DN80 PN40	7.87"	6.30"	0.71"	0.94"	0.08"		0.31"	2.99"	
3" ANSI Cl. 150	7.50"	6.00"	0.75"	0.94"	0.06"	5.00"	0.16"	2.99"	
3" ANSI Cl. 300	8.25"	6.63"	0.87"	1.12"	0.06"		0.31"	2.99"	
DN100 PN16	8.66"	7.09"	0.71"	0.79"	0.08"	5.87"	0.31"	3.50"	
DN100 PN40	9.25"	7.48"	0.87"	0.94"	0.08"	5.87"	0.31"	3.50"	
4" ANSI Cl. 150	9.00"	7.50"	0.75"	0.94"	0.06"	6.19"	0.31"	3.50"	
4" ANSI Cl. 300	10.00"	7.87"	0.87"	1.26"	0.06"	6.19"	0.31"	3.50"	



Heavy Duty Differential Pressure Transmitter Model PAD







Diaphragm Seal Models (Remote Assembly)

(Standard device without additional options (e.g. coatings, special materials etc.).

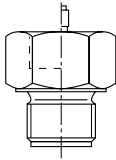
For dimensions/technical data, see DRM data sheet. Accuracy: 0.075% of calibrated span + influence of seal).

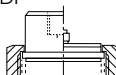
Over and under ranges of the min./max. span may be possible, but must be verified by KOBOLD for each application.

The indicated min./max. spans do not consider any coating of diaphragm seals. For additional information contact KOBOLD.

Model DRM	Size Code	Size	Note	Ø Diaphragm (mm)	Max. Media Temperature	Min. Span (PSIG)	Max. Span (PSIG)
DRM-601 	R15	G ½	Fixed Male Thread with Capillary	Ø 18	392 °F	0...87	14500
	R20	G ¾		Ø 23.8		0...36.3	14500
	R25	G 1		Ø 29.5		0...23.2	8700
	R32	G 1 ¼		Ø 38		0...14.5	8700
	R40	G 1 ½		Ø 40		0...14.5	8700
	N15	½" NPT		Ø 18		0...87	14500
	N20	¾" NPT		Ø 18		0...87	14500
	N25	1" NPT		Ø 23.8		0...36.3	8700
	N32	1 ¼" NPT		Ø 34.5		0...23.2	8700
	M20	M20 x 1.5		Ø 18		0...87	8700
	M48	M 48 x 3		Ø 40		0...14.5	8700
DRM-603 DIN 11851 	R20	DN 20	Dairy Connection, Capillary	Ø 18	392 °F	0...87	580
	R25	DN 25		Ø 23.8		0...36.3	580
	R32	DN 32		Ø 29.5		0...23.2	580
	R40	DN 40		Ø 38		0...14.5	580
	R50	DN 50		Ø 45.5		0...8.7	362.5
	R65	DN 65		Ø 64		0...5.8	362.5
	R80	DN 80		Ø 64		0...5.8	362.5
	R1H	DN 100		Ø 64		0...5.8	362.5
DRM-605 IDF 	R25	1"	IDF Socket with Union Nut, Capillary	Ø 29.5	392 °F	0...23.2	580
	R40	1 ½"		Ø 42		0...14.5	580
	R50	2"		Ø 56		0...8.7	580
DRM-606 	R20	G ¾	Capsule Seal with Rotable Male, Capillary	Short capsule	662 °F	0...145	8700
	R28	M28 x 1,5				0...145	8700
DRM-608/1 	R20	G ¾	Capsule Seal with Union Nut, Capillary	Long capsule	662 °F	0...23.2	8700
	R25	G 1	Capsule Seal with Union Nut, Capillary	Long capsule		0...23.2	8700
DRM-611 SMS 	R40	1 ½"	SMS Socket with Union Nut, Capillary	Ø 34.5	392 °F	0...23.2	580
	R50	2"		Ø 45.5		0...8.7	580

* Note: Threaded diaphragm seal only available with PAD-G/A. For PAD-D only flange, clamp connections or union nut are possible

Diaphragm Seal Models (Remote Assembly)

(Standard device without additional options (e.g. coatings, special materials etc.).

For dimensions/technical data, see DRM data sheet. Accuracy: 0.075% of calibrated span + influence of diaphragm seal).

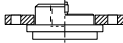
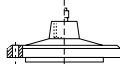
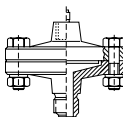
Model DRM	Size Code	Size	Note	Ø Diaphragm (mm)	Max. Media Temperature	Min. Span (PSIG)	Max. Span (PSIG)
DRM-613 Clamp 	R25	1"	Tri-Clamp, Capillary	Ø 18	392 °F	0...8.7	232
	F40	1 ½"		Ø 35.5		0...23.2	232
	F50	2"		Ø 45.5		0...8.7	232
	R65	2 ½"		Ø 52		0...8.7	232
	R80	3"		Ø 64		0...5.8	145
DRM-615 APV-RJT 	R20	1"	Union-nut, Capillary	Ø 29.5	392 °F	0...36.3	1450
	R40	1 ½"		Ø 42.5		0...14.5	1450
	R50	2"		Ø 56		0...8.7	1450
DRM-617 	R45	M45 x 2	Union-nut, Capillary	Ø 23.8	248 °F	0...36.3	23200
DRM-620 	R20	G¾	Union-nut, Capillary	Ø 23.8	662 °F	0...36.3	8700
DRM-620/1 	R20	G¾	Union-nut, capillary	Ø 23.8	662 °F	0...36.3	8700
DRM-622/1 	F48	Ø 48 mm	Flange, Capillary	Ø 48	392 °F	0...8.7	580
	F48 1	Ø 48 mm		Ø 48		0...8.7	580
	F48 2	Ø 48 mm		Ø 48		0...8.7	580
DRM-624/1 	F1H	Ø 100 mm	Flange, Capillary	Ø 63.5	482 °F	0...5.8	580
DRM-625/1 	R15	G½	Fixed male, Capillary	Ø 63.5	482 °F	0...5.8	580
	N15	½" NPT				0...5.8	580
	I15	G½ male				0...5.8	580

* Note: Threaded diaphragm seal only available with PAD-G/A. For PAD-D only flange, clamp connections or union nut are possible



Heavy Duty Differential Pressure Transmitter Model PAD

Diaphragm Seal Models (Direct or Remote Assembly)

(Standard device without additional options (e.g. coatings, special materials etc.).

For dimensions/technical data, see DRM data sheet. Accuracy: 0.075% of calibrated span + influence of diaphragm seal).

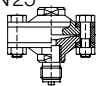
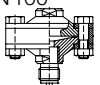
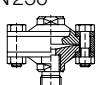
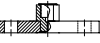
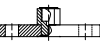
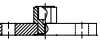
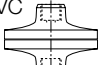
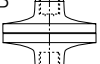
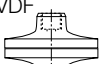
Model DRM	Size Code	Size	Note	Ø Diaphragm (mm)	Max. Media Temperature	Min. Span (PSIG)	Max. Span (PSIG)
DRM-627 PN25 	R08A025	G ¼ male	Fixed Male, Capillary	Ø 56	482 °F	0...8.7	362.5
	R08I025	G ¼ female	Fixed Female, Capillary	Ø 56		0...8.7	362.5
	R15A025	G ½ male	Fixed Male, Capillary	Ø 56		0...8.7	362.5
	R15I025	G ½ female	Fixed Female, Capillary	Ø 56		0...8.7	362.5
	N15A025	½" NPT male	Fixed Male, Capillary	Ø 56		0...8.7	362.5
DRM-627 PN100 	R08A100	G ¼ male	Fixed Male, Capillary	Ø 56	482 °F	0...8.7	1450
	R08I100	G ¼ female	Fixed Female, Capillary	Ø 56		0...8.7	1450
	R15A100	G ½ male	Fixed Male, Capillary	Ø 56		0...8.7	1450
	R15I100	G ½ female	Fixed Female, Capillary	Ø 56		0...8.7	1450
	N15A100	½" NPT male	Fixed Male, Capillary	Ø 56		0...8.7	1450
DRM-627 PN250 	R08A250	G ¼ male	Fixed Male, Capillary	Ø 56	482 °F	0...8.7	3625
	R08I250	G ¼ female	Fixed Female, Capillary	Ø 56		0...8.7	3625
	R15A250	G ½ male	Fixed Male, Capillary	Ø 56		0...8.7	3625
	R15I250	G ½ female	Fixed Female, Capillary	Ø 56		0...8.7	3625
	N15A250	½" NPT male	Fixed Male, Capillary	Ø 56		0...8.7	3625
DRM-629 PN06 	F25P06	DN25	Flange to EN1092-1, Capillary	Ø 24	482 °F	0...36.3	87
	F32P06	DN32		Ø 30		0...36.3	87
	F40P06	DN40		Ø 38		0...14.5	87
	F50P06	DN50		Ø 48		0...8.7	87
	F65P06	DN65		Ø 64		0...5.8	87
	F80P06	DN80		Ø 64		0...5.8	87
	F1HP06	DN100		Ø 64		0...5.8	87
DRM-629 PN16 	F25P16	DN25	Flange to EN1092-1, Capillary	Ø 24	482 °F	0...36.3	232
	F32P16	DN32		Ø 30		0...36.3	232
	F40P16	DN40		Ø 38		0...14.5	232
	F50P16	DN50		Ø 48		0...8.7	232
	F65P16	DN65		Ø 64		0...5.8	232
	F80P16	DN80		Ø 64		0...5.8	232
	F1HP16	DN100		Ø 64		0...5.8	232
DRM-629 PN40 	F25P40	DN25	Flange to EN1092-1, Capillary	Ø 24	482 °F	0...36.3	580
	F32P40	DN32		Ø 30		0...36.3	580
	F40P40	DN40		Ø 38		0...14.5	580
	F50P40	DN50		Ø 48		0...8.7	580
	F65P40	DN65		Ø 64		0...5.8	580
	F80P40	DN80		Ø 64		0...5.8	580
	F1HP40	DN100		Ø 64		0...5.8	580
DRM-630/1 PVC 	R08	G ¼ female	Fixed Female, Capillary	Ø 64	104 °F	0...5.8	145
	R15	G ½ female		Ø 64		0...5.8	145
	N15	½" NPT female		Ø 64		0...5.8	145
DRM-631/1 PP 	R08	G ¼ female	Fixed Female, Capillary	Ø 64	104 °F	0...5.8	145
	R15	G ½ female		Ø 64		0...5.8	145
	N15	½" NPT female		Ø 64		0...5.8	145
DRM-632/1 PVDF 	R08	G ¼ female	Fixed Female, Capillary	Ø 64	122 °F	0...5.8	232
	R15	G ½ female		Ø 64		0...5.8	232
	N15	½" NPT female		Ø 64		0...5.8	232

* Note: Threaded diaphragm seal only available with PAD-G/A. For PAD-D only flange, clamp connections or union nut are possible



Diaphragm Seal Models (Direct or Remote Assembly)

(Standard device without additional options (e.g. coatings, special materials etc.).

For dimensions/technical data, see DRM data sheet. Accuracy: 0.075% of calibrated span + influence of diaphragm seal).

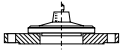
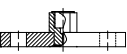
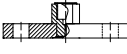
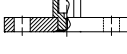
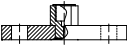
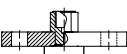
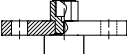
Model DRM	Size Code	Size	Note	Ø Diaphragm (mm)	Max. Media Temperature	Min. Span (PSIG)	Max. Span (PSIG)
 DRM-633/1	F50	DN50	Flange to DIN2527 Form C, Capillary	Ø 64	482 °F	0...3.6	580
	F1H	DN100		Ø 64		0...3.6	580
 DRM-635 150 lbs	A25P150	1"	Flange to ASME B16.5, Capillary	Ø 30	482 °F	0...36.3	145
	A32P150	1¼"		Ø 38		0...14.5	145
	A40P150	1½"		Ø 38		0...14.5	145
	A50P150	2"		Ø 48		0...8.7	145
	A65P150	2½"		Ø 48		0...8.7	145
	A80P150	3"		Ø 64		0...5.8	145
	A90P150	3½"		Ø 64		0...5.8	145
	A1HP150	4"		Ø 64		0...5.8	145
 DRM-635 300 lbs	A25P300	1"	Flange to ASME B16.5, Capillary	Ø 30	482 °F	0...36.3	290
	A32P300	1¼"		Ø 38		0...14.5	290
	A40P300	1½"		Ø 38		0...14.5	290
	A50P300	2"		Ø 48		0...8.7	290
	A65P300	2½"		Ø 48		0...8.7	290
	A80P300	3"		Ø 64		0...5.8	290
	A90P300	3½"		Ø 64		0...5.8	290
	A1HP300	4"		Ø 64		0...5.8	290
 DRM-635 600 lbs	A25P600	1"	Flange to ASME B16.5, Capillary	Ø 30	482 °F	0...36.3	580
	A32P600	1¼"		Ø 38		0...14.5	580
	A40P600	1½"		Ø 38		0...14.5	580
	A50P600	2"		Ø 48		0...8.7	580
	A65P600	2½"		Ø 48		0...8.7	580
	A80P600	3"		Ø 64		0...5.8	580
	A90P600	3½"		Ø 64		0...5.8	580
	A1HP600	4"		Ø 64		0...5.8	580
 DRM-635 1500 lbs	A25P1K5	1"	Flange to ASME B16.5, Capillary	Ø 30	482 °F	0...36.3	1450
	A32P1K5	1¼"		Ø 38		0...14.5	1450
	A40P1K5	1½"		Ø 38		0...14.5	1450
	A50P1K5	2"		Ø 48		0...8.7	1450
	A65P1K5	2½"		Ø 48		0...8.7	1450
	A80P1K5	3"		Ø 64		0...5.8	1450
	A90P1K5	3½"		Ø 64		0...5.8	1450
	A1HP1K5	4"		Ø 64		0...5.8	1450
 DRM-638 PN 06	F25P06	DN25	Flange to EN1092-1, Capillary	Ø 24	482 °F	0...36.3	87
	F32P06	DN32		Ø 30		0...14.5	87
	F40P06	DN40		Ø 38		0...14.5	87
	F50P06	DN50		Ø 48		0...8.7	87
	F65P06	DN65		Ø 64		0...8.7	87
	F80P06	DN80		Ø 64		0...5.8	87
	F1HP06	DN100		Ø 64		0...5.8	87
 DRM-638 PN 16	F25P16	DN25	Flange to EN1092-1, Capillary	Ø 24	482 °F	0...36.3	232
	F32P16	DN32		Ø 38		0...14.5	232
	F40P16	DN40		Ø 38		0...14.5	232
	F50P16	DN50		Ø 48		0...8.7	232
	F65P16	DN65		Ø 48		0...8.7	232
	F80P16	DN80		Ø 64		0...5.8	232
	F1HP16	DN100		Ø 64		0...5.8	232

* Note: Threaded diaphragm seal only available with PAD-G/A. For PAD-D only flange, clamp connections or union nut are possible



Heavy Duty Differential Pressure Transmitter Model PAD

Diaphragm Seal Models (Direct or Remote Assembly)

(Standard device without additional options (e.g. coatings, special materials etc.).

For dimensions/technical data, see DRM data sheet. Accuracy: 0.075% of calibrated span + influence of diaphragm seal).

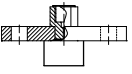
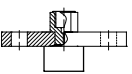
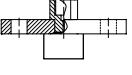
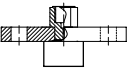
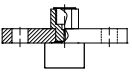
Model DRM	Size Code	Size	Note	Ø Diaphragm (mm)	Max. Media Temperature	Min. Span (PSIG)	Max. Span (PSIG)
DRM-638 PN 40 	F25P40	DN 25	Flange to EN1092-1, Capillary	Ø 30	482 °F	0 ... 36.3	580
	F32P40	DN 32		Ø 38		0 ... 14.5	580
	F40P40	DN 40		Ø 38		0 ... 14.5	580
	F50P40	DN 50		Ø 48		0 ... 8.7	580
	F65P40	DN 65		Ø 48		0 ... 8.7	580
	F80P40	DN 80		Ø 64		0 ... 5.8	580
	F1HP40	DN 100		Ø 64		0 ... 5.8	580
DRM-640 150 lbs 	A25P150	1"	Flange to ASME B16.5, Capillary	Ø 30	482 °F	0 ... 36.3	145
	A32P150	1¼"		Ø 38		0 ... 14.5	145
	A40P150	1½"		Ø 38		0 ... 14.5	145
	A50P150	2"		Ø 48		0 ... 8.7	145
	A63P150	2½"		Ø 48		0 ... 8.7	145
	A75P150	3"		Ø 64		0 ... 5.8	145
	A85P150	3½"		Ø 64		0 ... 5.8	145
	A1HP150	4"		Ø 64		0 ... 5.8	145
DRM-640 300 lbs 	A25P300	1"	Flange to ASME B16.5, Capillary	Ø 30	482 °F	0 ... 36.3	290
	A32P300	1¼"		Ø 38		0 ... 14.5	290
	A40P300	1½"		Ø 38		0 ... 14.5	290
	A50P300	2"		Ø 48		0 ... 8.7	290
	A63P300	2½"		Ø 48		0 ... 8.7	290
	A75P300	3"		Ø 64		0 ... 5.8	290
	A85P300	3½"		Ø 64		0 ... 5.8	290
	A1HP300	4"		Ø 64		0 ... 5.8	290
DRM-640 600 lbs 	A25P600	1"	Flange to ASME B16.5, Capillary	Ø 30	482 °F	0 ... 36.3	580
	A32P600	1¼"		Ø 38		0 ... 14.5	580
	A40P600	1½"		Ø 38		0 ... 14.5	580
	A50P600	2"		Ø 48		0 ... 8.7	580
	A63P600	2½"		Ø 48		0 ... 8.7	580
	A75P600	3"		Ø 64		0 ... 5.8	580
	A85P600	3½"		Ø 64		0 ... 5.8	580
	A1HP600	4"		Ø 64		0 ... 5.8	580
DRM-640 1500 lbs 	A25P1K5	1"	Flange to ASME B16.5, Capillary	Ø 30	482 °F	0 ... 36.3	1450
	A32P1K5	1¼"		Ø 38		0 ... 14.5	1450
	A40P1K5	1½"		Ø 38		0 ... 14.5	1450
	A50P1K5	2"		Ø 48		0 ... 8.7	1450
	A63P1K5	2½"		Ø 48		0 ... 8.7	1450
	A75P1K5	3"		Ø 64		0 ... 5.8	1450
	A85P1K5	3½"		Ø 64		0 ... 5.8	1450
	A1HP1K5	4"		Ø 64		0 ... 5.8	1450

* Note: Threaded diaphragm seal only available with PAD-G/A. For PAD-D only flange, clamp connections or union nut are possible



Diaphragm Seal Models (Direct or Remote Assembly)

(Standard device without additional options (e.g. coatings, special materials etc.).

For dimensions/technical data, see DRM data sheet. Accuracy: 0.075% of calibrated span + influence of diaphragm seal).

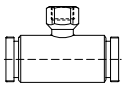
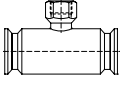
Model DRM	Size Code	Size	Note	Ø Diaphragm (mm)	Max. Media Temperature	Min. Span (PSIG)	Max. Span (PSIG)
DRM 501 ISO Sterile 	D15	DN 15	Inline, Capillary	Inline	176 °F	0 ... 36.3	580
	D20	DN 20		Inline		0 ... 36.3	580
	D25	DN 25		Inline		0 ... 14.5	580
	D32	DN 32		Inline		0 ... 14.5	580
	D40	DN 40		Inline		0 ... 8.7	580
	D50	DN 50		Inline		0 ... 8.7	580
DRM 503 Clamp ISO 2852 	D15	DN 15	Inline, Capillary	Inline	176 °F	0 ... 23.2	580
	D20	DN 20		Inline		0 ... 23.2	580
	D25	DN 25		Inline		0 ... 8.7	580
	D32	DN 32		Inline		0 ... 8.7	580
	D40	DN 40		Inline		0 ... 5.8	580
	D50	DN 50		Inline		0 ... 5.8	580

* Note: Threaded diaphragm seal only available with PAD-G/A. For PAD-D only flange, clamp connections or union nut are possible