

Plastic Vibrating Fork Level Switch



measuring
•
monitoring
•
analyzing

NWP



- All Plastic Construction
- Tolerates Foaming, Turbulence, and Coating
- Reliable, Solid State Design
- No Wearing Components
- NEMA 6 Rating



Order from: **C A Briggs Company**
622 Mary Street; Suite 101; Warminster, PA 18974
Phone: 267-673-8117 - Fax: 267-673-8118
Sales@cabriggs.com - www.cabriggs.com

KOBOLD Instruments, Inc.
1801 Parkway View Drive
Pittsburgh, PA 15205



Description

The KOBOLD NWP level switch operates by the vibrating fork principle and vibrates at a frequency of 400 Hz in air. When the fork is immersed in liquid or slurry, the vibration stops and this is detected by the electronics that activate an SPST relay. The rugged technology provides reliability for tough applications such as foaming, coating, and turbulent media. The all solid state design ensures longevity and the all plastic construction makes it ideal for many aggressive liquids. For optimum performance, the liquid level switch automatically adjusts for coating build up, and if necessary, outputs a proactive maintenance alarm to request cleaning. The low voltage SPST relay can replace semi-conductor outputs when wired appropriately. For a higher power switching capacity, pair the NWP with our RL-5901 or RL-5902 power supply and relay module.



Specifications

- Accuracy:** ± 1mm in Water
- Repeatability:** ± 0.5 mm in Water
- Frequency:** 400 Hz
- Fitting Size:** 3/4" NPT
- Wetted Parts:** Glass Filled PPS
- Housing:** Glass Filled PPS
- Media Temp. Range:** -40...176 °F
- Max. Pressure:** 150 PSIG @ 25 °C
Derated at 1.667 PSI / °C above 25°C

Electrical Ratings

- Protection:** NEMA 6 / IP 68
- Cable:** 10 Ft. Polypropylene Jacket, 24 AWG, 5-Conductor Shielded
- Power Supply:** 12-30 VDC, 25 mA Max
- Output Type:** SPST Relay Selectable NO / NC
- Max. Rating:** 60 VAC/VDC, 1 Amp, 60 VA
- Maintenance Alarm:** NPN Transistor Switch, 10 mA max.

Dimensions

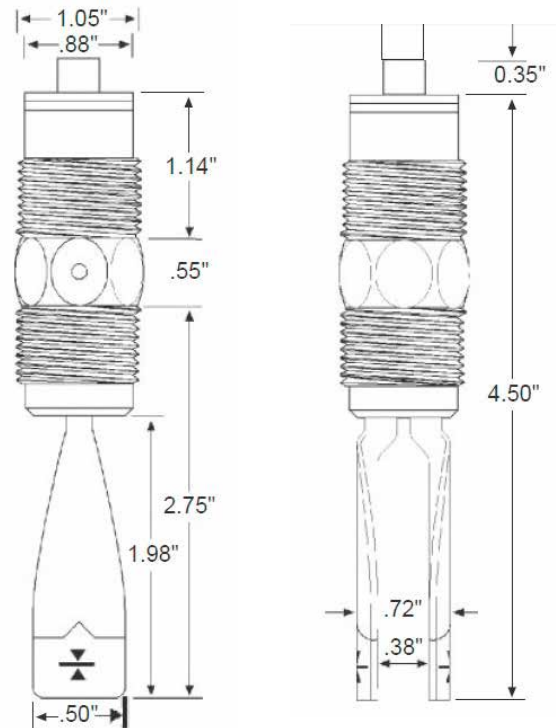

Order Details (Example: NWP-1405)

Model Number	Output
NWP-1405	SPST Relay