

Universal Panel Meter



measuring
•
monitoring
•
analyzing

DAG-T4



- Universal Panel Meter in 96 x 48 mm Format
- Short Mounting Depth of 32 mm
- Universal Input for Process Signals, Thermocouples, Pt100
- 16 mm High, Red LED Display
- 2 Alarm Outputs as Relay
- Programming via Buttons or Software



Order from: **C A Briggs Company**
622 Mary Street; Suite 101; Warminster, PA 18974
Phone: 267-673-8117 - Fax: 267-673-8118
Sales@cabriggs.com - www.cabriggs.com

KOBOLD Instruments, Inc.
1801 Parkway View Drive
Pittsburgh, PA 15205

Description

The KOBOLD DAG-T4 is a versatile process indicator with a totalizing function. It can measure the majority of variables encountered in most industrial processes. It can accept many input types, including: thermocouples, thermo resistance, voltage, and current. It also offers two alarms (six functions), sensor offset, configuration of parameters protected by password, USB communication, and temperature indication in either °C or °F.



Specifications

Display: Red LED, 5-Digit, 16 mm Digits
Range Input: -1999...30000
Range Totalizer: 0...9999999999 (Alternating Display)
Indicators: Ten Red Indicators for Alarm Status, Communication, Totalizer Function, Min/Max Value
°C, °F: On, Depending on Temp. Range
A1, A2: On, When Alarm is Active
TOT: On, When Displaying Totalizer Value
HIGH: On, When Digit 6 to 10 is Displayed
LOW: On, When Digit 1 to 5 is Displayed
Buttons: 4 Front Keys for Programming and Setting Setpoints
Input Range: Setup of Input Signal via Buttons
Thermocouples: Type J, K, T, N, R, S, B, E; Internal Cold Junction
RTD: Pt100 in 3-wire Connection (Alpha = 0.00385)
Linear Inputs: 0 V...5/10 V, 0/4 mA...20 mA, 0 mV...50 mV
Accuracy
Type J, K, T, E: 0.25% of Span, ±1 °C
Type N, R, S, B: 0.25% of Span, ±3 °C
Pt100: 0.2% of Span
Linear Analog Input: 0.2% of Span
Resolution: Internal Resolution with 65535 Steps (16 bits), Display Resolution 32000 Steps
Measurement Rate: 55 Hz with Programmable Digital Filter
Input Impedance: Thermocouples, Pt100, 0...50 mV: >10 MΩ

Excitation: 24 V_{DC} ± 15% @ 50 mA
Relay Outputs: 2 SPST Relays, 1.5 A @ 240 V_{AC}/30 V_{DC}
Supply: 100...240 VAC ± 10%, 50/60 Hz, 6 VA
Protection: IP 65 from the Front with Rubber Seal, IP 20 from the Back
Housing: Polycarbonate Plastic Case L94-V2, ABS & PC UI94 V-0 Back Panel
Dimensions: 96 mm W x 48 mm H x 35 mm D
 Panel Cut-out: 93.0 x 45.5 mm
Mounting: Plastic Clamps
Connection: Plug-in Terminal Blocks, 5 mm Pitch
Ambient Conditions: Operating Temperature: 0...50 °C; Relative Humidity: 80% RH @ 30 °C, for Temperatures above 30 °C, reduce RH by 3% for each °C

Connection Diagram

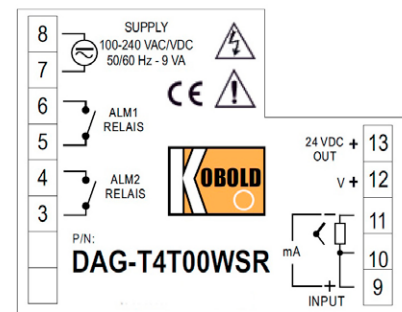

Order Details

Model
DAG-T4T00WSR

Sensor Type	Measurement Range
TC Type J	-166...1742 °F (-110...950 °C)
TC Type K	-238...2498 °F (-150...1370 °C)
TC Type T	-256...752 °F (-160...400 °C)
TC Type N	-454...2372 °F (-270...1300 °C)
TC Type R	-58...3200 °F (-50...1760 °C)
TC Type S	-58...3200 °F (-50...1760 °C)
TC Type B	752...3272 °F (400...1800 °C)
TC Type E	-130...1346 °F (-90...730 °C)
RTD	-328...1562 °F (-200...850 °C)