



All-Metal Variable Area Flowmeter

for liquids and gases



measuring
•
monitoring
•
analysing

BGK



- Measuring range:
0.1 - 1 l/h ... 20 - 200 l/h water
3 - 30 NI/h ... 600 - 6000 NI/h air
- Accuracy:
 $\pm 3\% q_G$ 50 acc. VDE/VDI 3513
- p_{\max} : PN40 bar; t_{\max} : 130°C
- Connection: flange DN10/15/25,
ASME 1/2", 3/4", 1"
- Material: stainless steel
- 1 or 2 inductive contacts
- Analogue output

15



Order from: **C A Briggs Company**

622 Mary Street; Suite 101; Warminster, PA 18974

Phone: 267-673-8117 - Fax: 267-673-8118

Sales@cabriggs.com - www.cabriggs.com

KOBOLD Messring GmbH
Nordring 22-24
D-65719 Hofheim/Ts.



Function

The fluid flows from bottom to top through the meter tube of the flowmeter. The float is lifted until an annular gap between the measuring cone and the float is produced which corresponds to the flow. The forces acting on the float are in equilibrium.

The height of the float resulting from the flow rate is transmitted by the permanent magnet in the float through the magnetic tracking system in a rotation to the pointer axis of the analog indicator unit.

The variable-area flowmeter consists of a stainless steel device with an integrated conical stainless steel measuring tube and a vertically movable float.

Application

The BGK meter is suitable for flow measurement of liquid or gaseous products in pipes.

It shows the current flow rate in volume or mass per unit in time.

Areas of Application

- Flow measurement of liquids and gases
- Can be used in the chemical industry or in medical or laboratory engineering
- Robust mechanical system with a low rate of wear

The devices are available with additional electrical equipment for process monitoring and control

- A variety of sealing materials
- High pressure application (option)
- Analogue output (option)

Technical Details

Materials

Indicator housing: polyamide, cover Ultramid
 Measuring cone, float, armature: stainless steel 1.4404/1.4571 other materials on request

Process connection: flange see order details

Nominal pressure: PN 40/300 lbs

Accuracy liquid/gas: ±3 % q_G 50 acc. VDE/VDI 3513

Process temperature:

Without limit contact/ electronic: -40°C...+130°C

With limit contact: NJ1,5-6,5N -25...+100°C; NJ2-11SN -40...+100°C

With analogue output: -40...+100°C (BGK-..E)

Ambient temperature: -25°C...+70°C

Weight: 2.4 kg

Protection: IP 65 (EN60529)

Display: %-scale measuring range scale

Certificate and Approval

Explosion protection: BVS 03 ATEX H/B 113

Pressure drop

Measuring range	H ₂ O/mbar
A	6
B	7.5
C	7.5
D	8
E	9
F	10
G	11
H	12
I	15
J	20
K	28

Order from: **C A Briggs Company**

622 Mary Street; Suite 101; Warminster, PA 18974

Phone: 267-673-8117 - Fax: 267-673-8118

Sales@cabriggs.com - www.cabriggs.com

No responsibility taken for errors; subject to change without prior notice.



Electrical contacts:

Limit contacts: 1 up to max. 2 inductive limit contacts, NAMUR (Pepperl & Fuchs NJ 1.5-6.5N); 8,2 V (Ri ~1KΩ) (NJ 2-11-SN); 5...25 V_{DC} (safety function)

Analogue output

(BGK-...E): 4-20 mA, 2-wire, passive; 14-30 V; load max. 500 Ω version Ex (intrinsically safe) connection via M12 plug

Ambient

temperature: -40 °C...+70 °C

Certificates and Approvals

Explosion protection

BGK-..E: BVS 12 ATEX E 093 X and IECEx BVS 12.0061X
 II 2 G Ex ib IIC T4 Gb or II 2D Ex ib IIC T135 °C Db
 NJ1,5-6,5N PTB 00 ATEX 2048 X II 2G Ex ia IIC T6-T4
 NJ 2-11SN PTB 00 ATEX 2049 X II 2G Ex ia IIC T6-T4
 ZELM 03 ATEX 0128 X II 1D Ex iaD 20 T...°C

CE-Marking: Explosion Protection Directive 94/9/EG, PED 97/23/EG

Electromagnetic compatibility

For add-on

electrical sensors: EMV-Directive 89/336/EWG EN 61326-1:2006

SIL: SIL Conformity acc. IEC-61508-2:2000 and IEC-61508-2:2010

Order Details (Example: BGK-301B A 0 A 0 0)

	Flange connection	Measuring range	Certificates ²⁾	Scale	Electrical output	Special version
BGK-	301B = DN 10, PN 40, Form B1 DIN EN 1092-1	A = 0.1 - 1.0 l/h H ₂ O; 3-30 NI/h air ¹⁾	0 = without			0 = without (Process temperature -40 °C...+130 °C) 1 = 1 x Inductive contact, initiator (NJ1.5-6.5-N) (Process temperature -25 °C...+100 °C) 2 = 2x Inductive contact (NJ1.5-6.5-N) (Process temperature -25 °C...+100 °C) 3 = 1 x Inductive contact (NJ2-11-SN) (Process temperature -25 °C...+100 °C) E = transmitter 4-20 mA without Hart®, Ex ib X = special acc. to specification
	305B = DN 15, PN 40, Form B1 DIN EN 1092-1	B = 0.25 - 2.5 l/h H ₂ O; 5-50 NI/h air ¹⁾				
	305D = DN 15, PN 40, Form D DIN EN 1092-1	L = special measuring range for gases only; 6-60 NI/h air ¹⁾				
	309B = DN 25, PN 40, Form B1 DIN EN 1092-1	M = special measuring range for gases only; 7-70 NI/h air ¹⁾				
	309D = DN 25, PN 40, Form D DIN EN 1092-1	N = special measuring range for gases only; 11-110 NI/h air ¹⁾				
	201R = ½" Class 150 RF, ASME B16.5-2003	C = 0.6 - 6.0 l/h H ₂ O; 18-180 NI/h air ¹⁾				
	221R = ½" Class 300 RF, ASME B16.5-2003	D = 1.0 - 10 l/h H ₂ O; 30-300 NI/h air ¹⁾				
	202R = ¾" Class 150 RF, ASME B16.5-2003	E = 1.6 - 16 l/h H ₂ O; 48-480 NI/h air ¹⁾				
	222R = ¾" Class 300 RF, ASME B16.5-2003	F = 2.5 - 25 l/h H ₂ O; 75-750 NI/h air ¹⁾				
	203R = 1" Class 150 RF, ASME B16.5-2003	G = 4.0 - 40 l/h H ₂ O; 120-1200 NI/h air ¹⁾				
	223R = 1" Class 300 RF, ASME B16.5-2003	H = 6.0 - 60 l/h H ₂ O; 180-1800 NI/h air ¹⁾				
	203J = 1" Class 150 RTJ, ASME B16.5-2003	I = 10 - 100 l/h H ₂ O; 300-3000 NI/h air ¹⁾				
	223J = 1" Class 300 RTJ, ASME B16.5-2003	J = 16 - 160 l/h H ₂ O; 480-4800 NI/h air ¹⁾				
	XXXX = special connection	K = 20 - 200 l/h H ₂ O; 600-6000 NI/h air ¹⁾				

¹⁾ Air 1,013 bar abs., 20 °C

²⁾ Certificate of compliance with the order 2.1, Test report 2.2, Inspection certificate 3.1 with material certificate (DIN EN 10204:2004) and Inspection certificate 3.2 with material certificate (DIN EN 10204:2004) on request



All-Metal Variable Area Flowmeter Model BGK

Dimensions [mm]

BGK

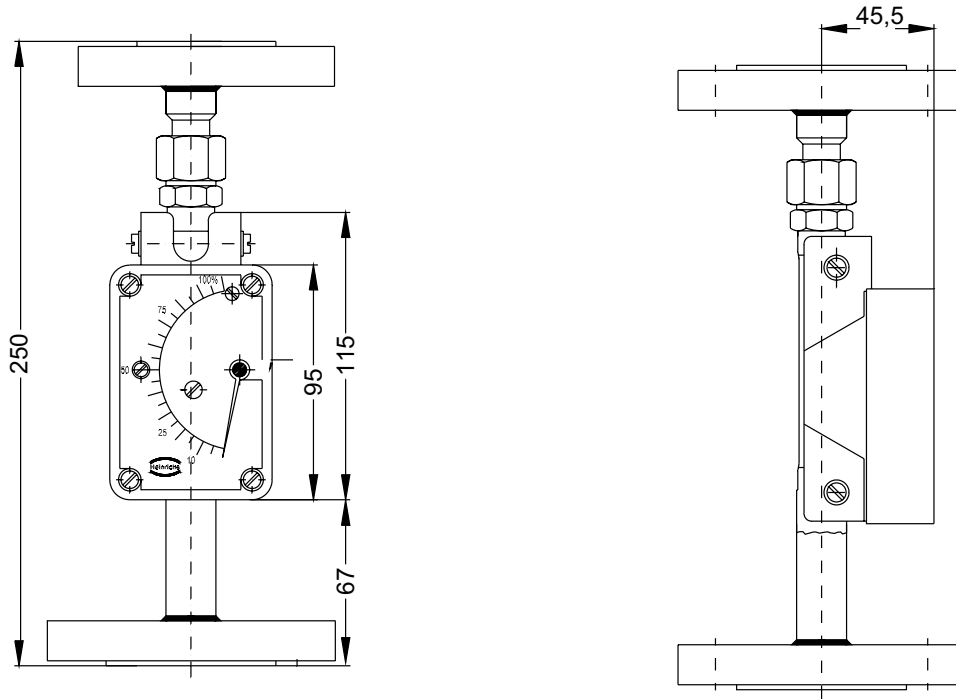

BGK-..E

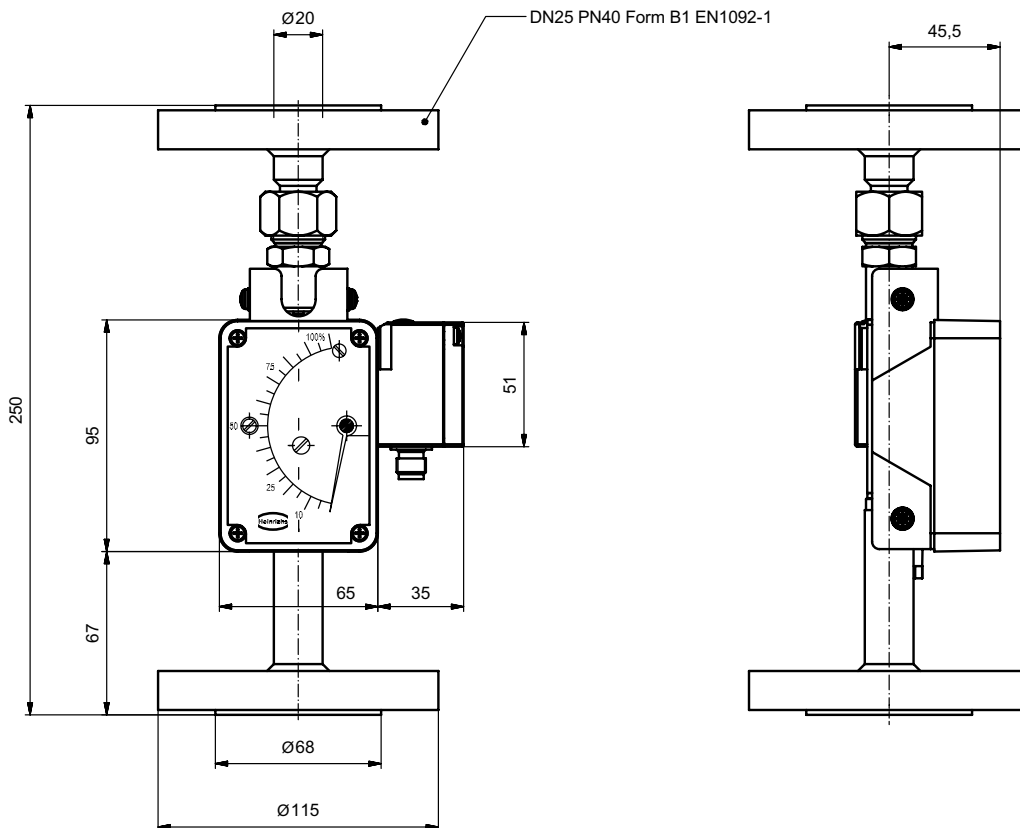

Order from: **C A Briggs Company**

622 Mary Street; Suite 101; Warminster, PA 18974

Phone: 267-673-8117 - Fax: 267-673-8118

Sales@cabriggs.com - www.cabriggs.com

No responsibility taken for errors;
subject to change without prior notice.