

## Small Size – Alloys

### XM/XT-860 Series – Compact, Resistive Output Level Sensors

- ▶ High Volume/Low Cost OEM Design
- ▶ Brass or Stainless Steel Construction
- ▶ 1/2" or 1" Resolution
- ▶ Lengths to 24 inches (610 mm)

OEMs with fluid gauging requirements now have an affordable, yet robust continuous output sensor they can use to great value. Gems XM-860 liquid level sensors are a durable, low-cost solution for applications that don't require high-resolution output. Made of brass or stainless steel, this series offers rugged construction, utilizing a new, coated reed switch core that stands up to high levels of shock and vibration. They are equally at home in applications ranging from tranquil storage day tanks to the challenge of off-highway vehicle fluids tank gauging. Minimum order for this series is 250 units.

#### Gems XM-860 Advantages

- Floats provide true reading of liquid's surface position
- Floats can be used to sense dissimilar liquid interfaces (e.g. water/oil interface), including resulting emulsions.
- Unaffected by dielectric property of fluid
- Intrinsically-safe and Explosion-proof models available
- Unaffected by turbulence and motion

#### Typical Applications

- Generator Sets Fuel Tanks
- Auto Transmissions Fluid Reservoirs
- Reclamation Systems
- OHV Fuel Tanks
- Coolant Reservoirs
- Storage Day Tanks

### 1. Mounting Types

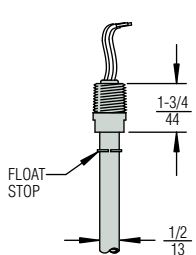
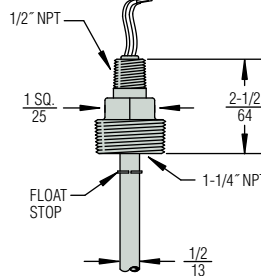
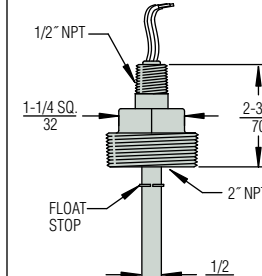
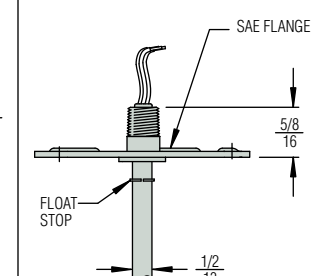
	Type 1 1/2" NPT Internal Mount	Type 2 1-1/4" NPT External Mount	Type 3 2" NPT External Mount	Type 4 SAE Flange External Mount
				
<b>Stem Material</b>	Brass or 316 Stainless Steel			Brass
<b>Mounting Material</b>	Brass or 316 Stainless Steel			Brass
<b>Float Stop Material</b>	Brass Units: Beryllium Copper Grip Rings; Stainless Steel Units: S.S. ARMCO PH-15-7MO Grip Rings			
<b>Stem Length</b>	24 inches (610 mm), Max.			
<b>Output Wiring</b>	Lead Wires Only	Lead Wires or Junction Box*		

\* Explosion-Proof (EP) units are supplied with junction box. Junction boxes for IS- or non-rated units may be ordered separately—P/N 113873.



**ORDER IT!**

Ordering is Easy! See Page C-15.  
Easy online ordering too!

LEVEL SENSORS – CONTINUOUS

## 2. Output Types

Make ordering selections from *either* the 2-wire or 3-wire output types detailed below.

### 2a. 2-Wire Versions, 1-inch Resolution

Designed for simplicity and economy, 2-wire resistive-output versions connect directly to many common automotive-type panel meters. Accuracy is 1 inch. Select the output resistance code from the table below for your Order Check List.

Output Resistance				
Resistance Code	Top Hard Stop	Individual Step R	Full Transition	Unit
R1	33	240-33 A (In.)	240	Ohms
R2	33	255-33 A (In.)	255	Ohms
R3	240	240-33 A (In.)	33	Ohms
R4	255	255-33 A (In.)	33	Ohms

High Resistance =  $\pm 2.75$   
Low Resistance =  $33 \pm 0.50$

#### Electrical Rating – Red to Black Wire

Resistance	33-240 or 33-255
Minimum Resistance	1000 Ohms
Maximum Voltage	30.0 VDC
Maximum Current	0.030 Amps
Maximum Power Dissipation	0.10 Watts/Inch of Indication

### 2b. 3-Wire Versions, 1/2-inch Resolution

These versions connect to Gems signal-conditioners (optionally selected in step 6b) for a variety of VDC and mA outputs. Accuracy is 1/2 inch. The standard resistance code is shown below. Consult factory for other resistance values.

Resistance Code	Resistance Value			
	R <sub>Lead</sub>	R	R <sub>Lag</sub>	Unit
P1	0	100	0	Ohms

Total Indicating R =  $R_{Lead} + (A \text{ (In.)} * R) + R_{Lag}$

#### Electrical Rating – Red to Black Wire

Minimum Resistance	1000 Ohms
Maximum Voltage	30.0 VDC
Maximum Current	0.030 Amps
Maximum Power Dissipation	0.10 Watts/Inch of Indication

## 3. Output Options

- A. Non-Rated Units.** Supplied with lead wire output; junction box optional. (See below.)
- B. Explosion-Proof Rated Units.** Supplied from factory with explosion-proof junction box.
- C. Intrinsically-Safe Rated Units.** Supplied with lead wire output; junction box optional. (See below.)
- D. Optional Junction Boxes – P/N 113873.** Simplify and protect wire connections for any non-Explosion-Proof Rated Unit. Optional Junction Boxes are supplied separately and must be assembled and wired by customer.

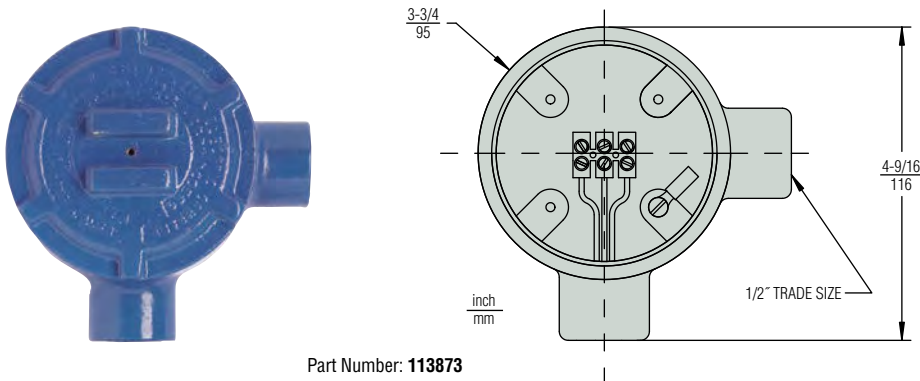

### 4. Float Types

Make selection based on Mounting Type being used and performance requirements.

**IMPORTANT:** If you are specifying either an Explosion-Proof or Intrinsically-Safe output, you must select a stainless steel float here.

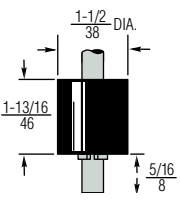
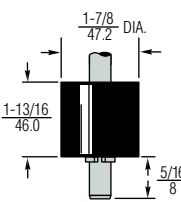
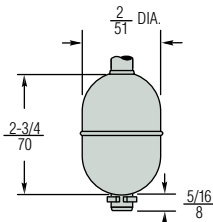
Float Material	Buna N	Buna N	316 Stainless Steel
Compatible Mountings	Type 1, 2, 3, 4	Type 1 & 3	Type 1 & 3
Float Dimensions  inch mm			
Part Number	197428	43359	43590
Min. Liquid Specific Gravity	.63	.55	.75
Operating Pressure, Max*	150 PSI (10.3 bar)		300 PSI (20.7 bar)
Operating Temperature, Max.	Water: 180°F (82°C) Oil: 230°F (110°C)		300°F (149°C)

\*@ Ambient Temperature

### 5. To Determine Dimensions

**X:** Dimensional factor based on selected float (see table below)

**B:** Overall Length = Inches of Indication + C\*\* + X

**C:** Distance from bottom of mounting to float stop (customer specified):

- 1/4" (6.4mm) minimum
- 1-1/4" (31.8mm) minimum on Type 1, XT Series only

**M:** Distance from stem bottom to lowest level of indication

**N:** Distance from upper float stop to highest level of indication

#### Calculating Length

Note: 2-wire output units must specify Inches of Indication in even increments of 1 inch;  
3-wire output units must be specified in even increments of 1/2 inch.

To find Overall Length when Inches or Indication is known:

- Inches of Indication + C\*\* + X = Overall Length

To find Maximum Inches of Indication when Overall Length is known:

- Overall Length - C\*\* - X = Maximum Inches of Indication

\*\* C dimension is determined by customer.

If not specified, the float stop will be located at the minimum value (1/4").

### Float Factors

Float Part Number	X Factor	M Dimension	N Dimension
197428	2.5 (63.5)	1.312 (33.3)	1.187 (30.1)
43359	2.5 (63.5)	1.312 (33.3)	1.187 (30.1)
43590	3.437 (87.3)	2.187 (55.5)	1.25 (31.7)

inch (mm)

M and N Dimensions are based on water (specific gravity 1.0).

Typical Configuration

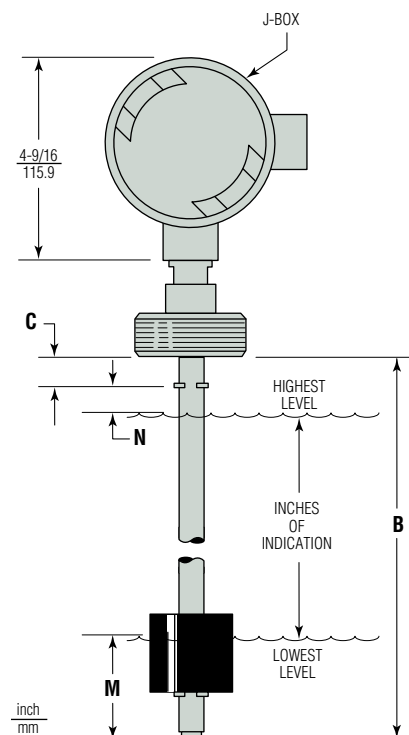

<p style="font-size: 24pt; font-weight: bold;">267-673-8118</p> <p style="font-size: 24pt; font-weight: bold; color: green;">Photocopy This Form</p> <p>Use one form for each product type you are selecting.</p> <p><small>This form may also be completed online at <a href="http://gemssensors.com">gemssensors.com</a> for RFQ.</small></p>	This is a <input type="checkbox"/> Request for a Quote <input type="checkbox"/> Order P.O.# _____ Quantity Needed _____ Date Required ____/____/____ Shipping Method: _____ Partial Accepted: <input type="checkbox"/> Yes <input type="checkbox"/> No	Name _____ Company _____ Street _____ City _____ State ____ Zip _____ Phone (____) _____ Fax (____) _____
---	--	--

## Float Type Level Transmitters – XM/XT-860 Series

### Application Environmental Conditions

This information is essential to the accurate and proper operation of your GEMS configurable sensors. Please complete fully and accurately.

- |   |   |
|---|---|
| <p><b>1. Liquid Media:</b> _____</p> <p><b>2. Pressure:</b> Minimum _____ psig    Maximum _____ psig</p> <p><b>3. Temperature:</b> Minimum _____ °F    Maximum _____ °F</p> <p><b>4. Specific Gravity:</b> Minimum _____    Maximum _____</p> | <p><b>5. Viscosity:</b> _____ SSU</p> <p><b>6. Tank Material:</b> _____</p> <p><b>Tank Depth:</b> _____</p> <p><b>7. Unit is Mounted In:</b> <input type="checkbox"/> Tank Top    <input type="checkbox"/> Tank Bottom</p> <p><b>8. Moisture Protection Required?</b> <input type="checkbox"/> Yes    <input type="checkbox"/> No</p> |
|---|---|

#### 1. Series

- XM/XT-860 (1/2" Resolution) – 3 wire output  
 XM/XT-860 (1" Resolution) – 2 wire output

#### 2. Mounting Type

- Type 1 (1/2" NPT)                       Type 2 (1-1/4" NPT)  
 Type 3 (2" NPT)                          Type 4 (SAE Flange)

#### 3. Materials

- a. Stem:  
 Brass                       316 Stainless Steel
- b. Mounting:  
 Brass                       316 Stainless Steel\*
- \*Type 1, 2, & 3 only

#### 4. Float Type

- 197428** – Buna N (Use with any Mounting Type)  
 **43359** – Buna N (Use **only** with Mounting Type 1 or 3)  
 **43590** – Stainless Steel (Use **only** with Mounting Type 1 or 3)

#### 5. Dimensions

Overall Length (complete one line only):

Float Selected	Indicating Length <sup>1</sup> (Whole Inches)	+	C Dimension ±1/16" (1.6mm)	+	Float Factor X Inch (mm)	=	Overall Length 24" (610 mm) Max.
<b>197428</b>		+		+	2.5 (63.5)	=	
<b>43359</b>		+		+	2.5 (63.5)	=	
<b>43590</b>		+		+	3.44 (87.3)	=	

- Notes:  
 1. Indicating Length: 1" increments  
 2. Minimum C Dimension = 1/4"

#### 6. Input/Output

- a. Optional 24 VDC Power Supply:  
 115 VAC input     230 VAC input
- b. Signal Conditioners  
 Output Shown in Parenthesis:  
 51965 (0-5 VDC – stem)  
 51970 (0-12 VDC – stem)  
 52536 (0-5 VDC – J-box)  
 52537 (0-12 VDC – J-box)  
 52555 (4-20 mA – J-box)  
 112300 (4-20 mA – panel mount)

Please Contact **C A Briggs Company** for any Special Configurations  
 Or requirements not covered on this form. **267-673-8117**

Quote: \$ \_\_\_\_\_    Date Quoted: \_\_\_\_/\_\_\_\_/\_\_\_\_

Order from: **C A Briggs Company**; 622 Mary Street, Suite 101 - Warminster, PA 18974  
 Phone: 267-673-8117 - Fax: 267-673-8118; E-Mail: [Sales@cabriggs.com](mailto:Sales@cabriggs.com) - [www.cabriggs.com](http://www.cabriggs.com)

