

Order from: **C A Briggs Company**  
622 Mary Street; Suite 101; Warminster, PA 18974  
Phone: 267-673-8117 - Fax: 267-673-8118  
[Sales@cabriggs.com](mailto:Sales@cabriggs.com) - [www.cabriggs.com](http://www.cabriggs.com)



# Mark-4™/GP-4™ Yo-Yo™ Installation & Operation Manual







# Mark-4™/GP-4™ Yo-Yo™ Installation & Operation Manual

## CONTENTS

<b>I. HANDLING &amp; STORAGE</b> .....	<b>1</b>
Inspection and Handling	
Disposal and Recycling	
Storage	
<b>II. GENERAL SAFETY</b> .....	<b>2</b>
Authorized Personnel	
Use	
Misuse	
<b>III. PRODUCT DESCRIPTION</b> .....	<b>3</b>
Function	
Applications	
Features	
Technical Specifications	
Approvals	
<b>IV. MECHANICAL INSTALLATION</b> .....	<b>6</b>
Guidelines	
General Installation	
Remote Display Unit Installation	
<b>V. ELECTRICAL INSTALLATION</b> .....	<b>7</b>
General Safety	
Disconnect Requirements for Permanently Installed Equipment	
Protective Earth Ground	
Guidelines	
Set Sensor Address	
Figure 1. Wiring for Multiple Unit-To-Remote Display	
Figure 2. Board Layout - Sensor Address Location	
Figure 3. Board Layout	
Figure 4. Single Unit-To-Remote Display Wiring	
<b>VI. SET-UP</b> .....	<b>11</b>
Lines of Display	
Operating Mode Functions	
Program Mode Functions	
To Program a Sensor	
Settings Menu	
Definitions & Menu Descriptions	
<b>VII. MAINTENANCE</b> .....	<b>19</b>
Preventative Maintenance	
Replacement Parts	
<b>VIII. TROUBLESHOOTING</b> .....	<b>20</b>
<b>IX. DIMENSIONAL DRAWINGS</b> .....	<b>22</b>

## SAFETY SYMBOLS



### **WARNING:**

IDENTIFIES CONDITIONS OR PROCEDURES, WHICH IF NOT FOLLOWED, COULD RESULT IN SERIOUS INJURY. RISK OF ELECTRICAL SHOCK.



### **CAUTION:**

IDENTIFIES CONDITIONS OR PROCEDURES, WHICH IF NOT FOLLOWED, COULD RESULT IN SERIOUS DAMAGE OR FAILURE OF THE EQUIPMENT.

# Mark-4™/GP-4™ Yo-Yo™

## I. HANDLING AND STORAGE

### SAVE THESE INSTRUCTIONS

#### INSPECTION AND HANDLING

Do not dispose of the carton or packing materials.

Each package should be inspected upon receipt for damage that may have occurred due to mishandling during shipping. If the unit is received damaged, notify the carrier or the factory for instructions. Failure to do so may void your warranty. If you have any problems or questions, consult Customer Support at 1-800-778-9242.

#### DISPOSAL AND RECYCLING

This product can be recycled by specialized companies and must not be disposed of in a municipal collection site. If you do not have the means to dispose of properly, please contact Bindicator for return and disposal instructions or options.

#### STORAGE

If the device is not scheduled for immediate installation following delivery, the following steps should be observed:

1. Following inspection, repackage the unit into its original packaging.
2. Select a clean dry site, free of vibration, shock and impact hazards.
3. If storage will be extended longer than 30 days, the unit must be stored at temperatures between 32° and 158° F (0° to 70° C) in non-condensing atmosphere with humidity less than 85%.



**CAUTION: DO NOT STORE A NON-POWERED UNIT OUTDOORS FOR A PROLONGED PERIOD.**

## II. GENERAL SAFETY

### **AUTHORIZED PERSONNEL**

All instructions described in the document must be performed by authorized and qualified service personnel only. Before installing the unit, please read these instructions and familiarize yourself with the requirements and functions of the device. The required personal protective equipment must always be worn when servicing this device.

### **USE**

The device is solely intended for use as described in this manual. Reliable operation is ensured only if the instrument is used according to the specifications described in this document. For safety and warranty reasons, use of accessory equipment not recommended by the manufacturer or modification of this device is explicitly forbidden. All servicing of this equipment must be performed by qualified service personnel only. This device should be mounted in locations where it will not be subject to tampering by unauthorized personnel.

### **MISUSE**

Improper use or installation of this device may cause the following:

- Personal injury or harm
- Application specific hazards such as vessel overfill
- Damage to the device or system

If any questions or problems arise during installation of this equipment, please contact the Customer Support at 800-778-9242.

### III. PRODUCT DESCRIPTION

#### FUNCTION

The Bindicator® Yo-Yo™ is a sensor that is mounted to the top of a vessel and measures the distance to the product in the tank. This is done by lowering a weight to the surface of the product, while measuring the amount of cable used. When the weight contacts the material, the unit senses the loss of weight. The motor reverses and automatically returns the weight to its home position, sealing the weight against a bellows assembly in the bottom of the sensor housing. The cable is measured while traveling in both directions and the readings are compared. If these measured distances do not agree, the sensor automatically takes another measurement reading. A microprocessor located on board has the ability to convert this measured distance to “level of product” or “volume/weight of product” in the vessel. This value is communicated via RS-485 MODBUS to the remote display or ORB™. The signal may also be transmitted via 4-20 mA to other equipment.

#### APPLICATIONS

Bindicator Yo-Yo sensors provide level measurement in most dry bulk solid materials, liquid/solid interfaces, and liquids at atmospheric pressure. These sensors can be used for measurement of materials with temperatures of up to 200° F (93° C). Please consult the Bindicator Applications Department if this device will be used in material with temperatures above 200° F (93° C).

Locating the proper mounting location on the top of the tank is important. When filling bulk materials into a vessel, a positive angle of repose (mound up) is created. When emptying, the angle of repose may become negative. In a round, center fill-and-discharge vessel, the point that best averages this angle of repose is located at  $\frac{1}{6}$  the diameter of the tank (or  $\frac{1}{3}$  the radius) from the outside wall.

The Yo-Yo sensor, like any other plumb bob device, drops a weight into the vessel. If the material in the vessel buries this weight, the sensor will become inoperative. Therefore, it is not recommended that readings be taken when there is a chance the weight will be buried. This could occur when the vessel is being filled or discharged.

If material is sticky and will eventually build up on the weight, this will cause the weight to become stuck at its home position inside the standpipe. In order to avoid this, a tare stop is available. The tare stop will still seal against the bellows when in the “home” position, but the weight is left suspended below the standpipe. If build-up does occur on the weight, it will not become stuck because it never enters the standpipe.

Consideration should be given to air flow characteristics in the vessel when there is no product movement. The internal dynamics of bulk solids storage vessels can vary drastically. If your vessel includes air movement equipment that continuously filters or moves air, this could cause problems with the weight when it is dropped into the vessel. Air currents can cause the weight to swing or spin as it is being lowered or raised inside the vessel. If the weight spins, it can create knots in the cable. Knots in the cable could hinder the movement of the weight as it is being retracted, or on the next measurement when it is lowered. A swinging weight can be the cause of inaccurate readings or can abrade and eventually cut the cable as a result of rubbing on the edge of the standpipe at the top of the vessel.

## FEATURES

The Yo-Yo is the most application flexible and interconnection flexible sensor to date. This sensor provides both RS-485 MODBUS communications and an isolated, reversible 4-20 mA output. It can be cycled using a momentary contact closure such as a spring-loaded push button; or from the remote display by selecting 1 of up to 99 sensors and requesting a measurement; or by requesting the measurement via computer either on-site or off-site.

- Resolution
- Isolated 4-20 mA Output
- RS-485 (Modbus) Communication
- Automatic Cycle Timer
- Remote Measurement Request
- Remote Display

## TECHNICAL SPECIFICATIONS: MARK-4/GP-4 YO-YO

FUNCTIONAL	
Operating Power	115 VAC or 230 VAC
Power Consumption	50/60 Hz, 32 watts (operating), 4 watts (quiescent); with heater add 10 watts
Operating Temperature	32° to 120° F (0° to 49° C); with heater -31° to 120° F (-35° to 49° C)
Output	MODBUS, Analog 4-20 mA optically isolated (user sourced) into 600 ohms max
PERFORMANCE	
Repeatability	0.8 in (2 cm)
Measurement Span	Up to 100 ft standard
Automatic Timer	From 2 to 9999 minutes (approx. 1 week)
PHYSICAL	
Mounting	3" NPT
Conduit Entry	GP-4: 2 each 3/4" NPT, Mark-4: 3 each 3/4" NPT
Air Purge Connection	1/4" NPT
Enclosure Material	GP-4: Minlon® frame, low density polyethylene cover Mark-4: Polyester coated cast aluminum
Enclosure Rating	GP-4: NEMA 4 Mark-4: NEMA 4/7/9
Shipping Weight	GP-4: 13 lbs (6 kg) Mark-4: 26 lbs (12 kg)
OPTIONS	
	Motor Heater
	Yo-Yo Display
	ORB



## TECHNICAL SPECIFICATIONS: DISPLAY/PROGRAMMER

### FUNCTIONAL

Operating Power	Powered from Yo-Yo sensor (9-24 VDC); With optional heater, 120/240 VAC required
Operating Temperature	-4° to 158° F (-20° to 70° C); With optional heater: -40° to 158° F (-40° to 70° C)

### PHYSICAL

Communication	RS-485 MODBUS, Optional Integral Modem
Sensors	Up to 99
Display	4 lines by 20 characters, Backlit LCD Display
Keypad	NEMA 4X soft-touch
Enclosure	NEMA 4X molded fiberglass polyester

### PERFORMANCE

Wiring Requirements	Belden® 9842, 4 wire shielded cable
Wiring Distance	4000 ft max
Speed	115 Kbps
Protocol	MODBUS
Interface	RS-485
Internal Modem	Optional 56 K Modem

### APPROVALS

Mark-4	FM (US) - XP Class I, Division I, Groups C and D; T5, Ta= 60° C DIP Class II, III, Division I, Groups E, F, and G; T5, Ta= 60° C; Type 4 CSA - Class I, Groups C and D; Class II, Groups E, F and G; Class III; Type 5; Type 4 ATEX
GP-4	FM (US) - General Purpose CE

## IV. MECHANICAL INSTALLATION



**WARNING: REMOVE POWER FROM THE UNIT BEFORE INSTALLING, REMOVING OR MAKING ADJUSTMENTS.**

### GUIDELINES

- Should not be close to any fill point.
- To ensure material does not get into the enclosure, it is recommended that the unit be placed where an air purge is available.
- Sensing weights should weigh between 20 - 25 oz (567 - 709 g)
- The standard plastic weight and spike require additional weight to reach recommended weight; it is recommended that the weight be filled with the same material that is in the vessel.
- For round, center fill, center discharging vessels, it is recommended that mounting should be located at a point approximately  $\frac{1}{3}$  of the vessel radius from the vessel wall.
- For other types of vessel shapes, contact Customer Support for assistance in determining ideal mounting locations.

### GENERAL INSTALLATION

1. Determine location of where sensor should be on the top of the tank.
2. Insert unit into the tank with weight going into the vessel.
3. Mount the unit to the top of the vessel using a 3" NPT nozzle or pipe nipple extended vertically from the top.

**NOTE:** Due to how the weight is retracted, for the Digestible Bottle Weight a 12 in. (30.5 cm) nozzle is recommended; for the Stainless Steel Bob Weight a 3 in. (7.62 cm) nozzle is recommended. Other weights do not need additional considerations.

4. Secure the unit to the mounting/flange.
5. Proceed to Electrical Section for wiring instructions.

### REMOTE DISPLAY UNIT INSTALLATION

1. Determine location of display – should be mounted where it can be easily read by user.
2. Install feet on enclosure, tightening at the desired angles for mounting location.
3. Hold the enclosure against the wall in the desired location and mark the positions of the mounting holes. Place the enclosure in a safe location.
4. Drill the mounting holes into the wall.
5. Attach the enclosure to the wall using hardware (provided by the customer) that will secure it firmly in place.
6. Proceed to Electrical Section for wiring instructions.

## V. ELECTRICAL INSTALLATION



**WARNING: REMOVE POWER FROM THE UNIT BEFORE INSTALLING, REMOVING, OR MAKING ADJUSTMENTS.**

### GENERAL SAFETY

When using electrical equipment, you should always follow basic safety precautions, including the following:

- The installation and wiring of this product must comply with all national, federal, state, municipal, and local codes that apply.
- Properly ground the enclosure to an adequate earth ground.
- Do not modify any factory wiring. Connections should only be made to the terminals described in this section.
- All connections to the unit must use conductors with an insulation rating of 300 V minimum, rated for 221°F (105°C), a minimum flammability rating of VW-1, and be of appropriate gauge for the voltage and current required (see specifications).
- Do not allow moisture to enter the electronics enclosure. Conduit should slope downward from the unit housing. Install drip loops and seal conduit with silicone rubber product.

### DISCONNECT REQUIREMENTS FOR PERMANENTLY INSTALLED EQUIPMENT

A dedicated disconnecting device (circuit breaker) must be provided for the proper installation of the unit. If independent circuits are used for power input individual disconnects are required. Disconnects must meet the following requirements:

- Located in close proximity to the device
- Easily accessible to the operator
- Appropriately marked as the disconnect for the device and associated circuit
- Sized appropriately to the requirements of the protected circuit (See specifications)

### GUIDELINES

- Supplied power to sensors should be clean and free of interference.



**CAUTION: THE COMMUNICATIONS AND/OR 4-20 MA WIRING SHOULD NOT BE RUN IN THE SAME CONDUIT AS THE AC SUPPLY WIRING. TWO SEPARATE 3/4" CONDUIT OPENINGS ARE PROVIDED FOR THIS REASON.**

- If wiring multiple Yo-Yo units to the same remote display. Wire units to each other, then add the remote display at the end of the line. Do not wire individually or in the middle. (See Figure 1.)

Figure 1. Wiring for Multiple Unit-To-Remote Display

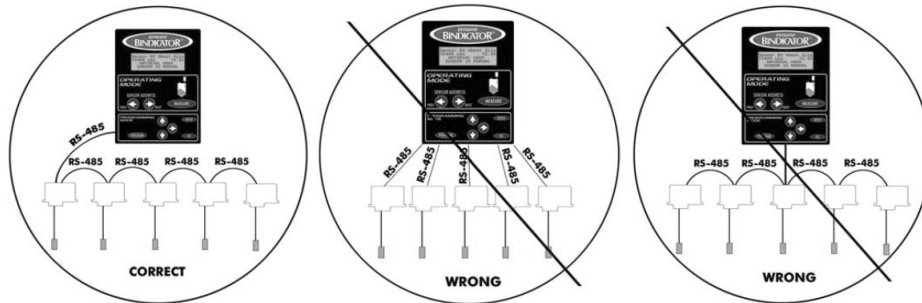

- The recommended communication cable is Belden #9842 (2-pair, AWG 24) or equivalent. Using this cable will allow a network distance up to 4000 ft (1219 m). The communications wiring, which consists of communication and DC Power to remote display, is polarity sensitive.



**WARNING: WIRING POWER INTO THE COMMUNICATION TERMINALS WILL RESULT IN PERMANENT DAMAGE TO THE ELECTRONICS. DOUBLE CHECK ALL COMMUNICATIONS WIRING BEFORE POWERING ANY SENSOR. DAMAGE CAUSED BY INCORRECT WIRING WILL VOID THE WARRANTY.**

- Each system/network must have two (2) End of Line Resistors (EOLR); one on each end of the communication cable. All sensor boards and the display have embedded resistors that introduced into the circuit via the EOLR jumper. See Figures 2 and 3.
- A pull-up resistor is recommended for communication lines greater than 1,000 ft (305 m). Two or three pull-up resistors can be used at various points for long lines, place them one quarter of the cable length away from each end of the network so that each pull-up resistor takes care of half the length of the cable from its middle.

### SET SENSOR ADDRESS

All sensors are shipped from the factory with address #01.

- Determine the sensor address for each unit - each sensor **MUST** have a unique address between 01 and 99 inclusive.

**Note: One Sensor must have an address of 01 or unit will not communicate with the system.**

- If more than one sensor was purchased, or new sensors are being added to an existing network, the sensors will need to be individually addressed.
- Once address switches have been set, the sensor must be re-initialized by pressing the reset button on board or by turning the power to the sensor off and back on again.

Figure 2. Board Layout - Sensor Address Location

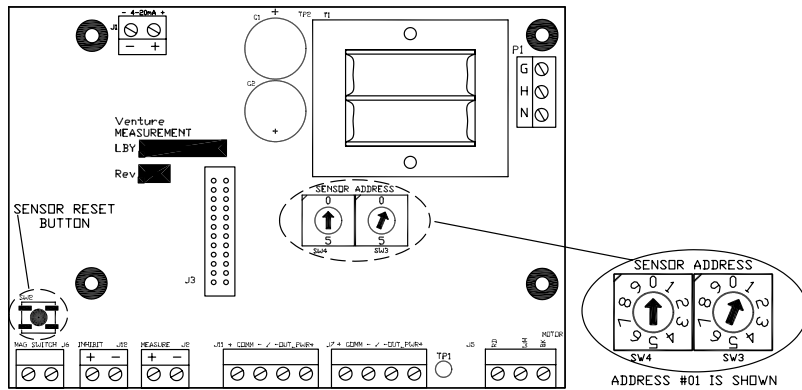
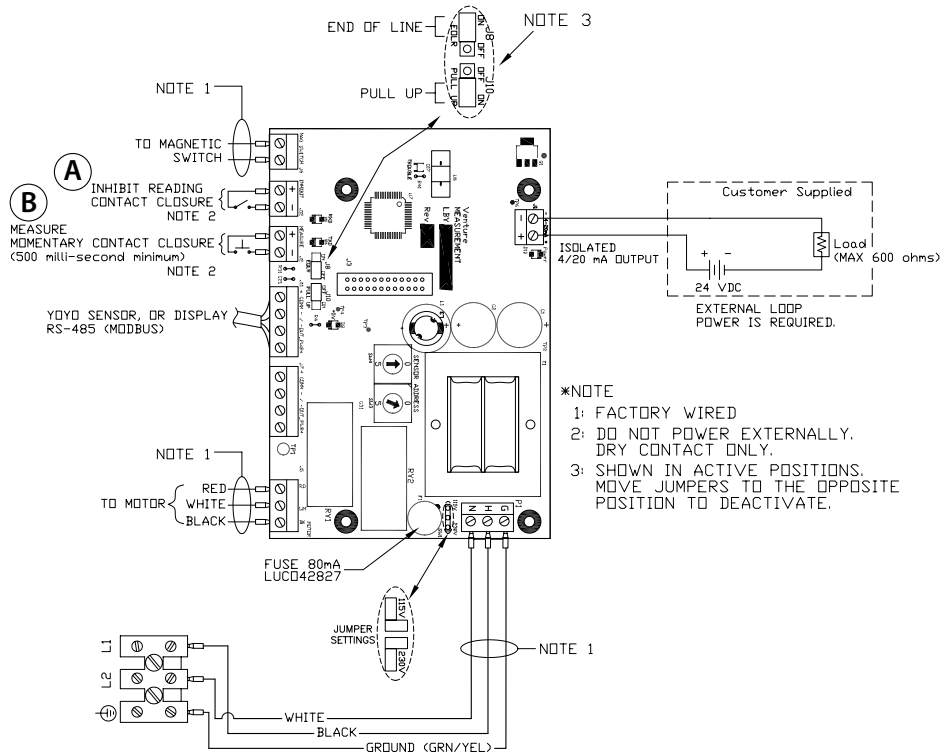

Figure 3. Board Layout



**INHIBIT FEATURE (A)**

Shorting these terminals or closing the circuit inhibits the sensor from taking a measure; regardless of what method the measurement is requested. The inhibit feature should be used to ensure the weight does not get buried by material during the filling process of the vessel. Multiple ways to use this contact closure setting; another device, PLC, or single switch.

**MEASURE FEATURE (B)**

The Yo-Yo level measuring device also allows the connection of a PLC digital output to request a reading of each sensor. This is a momentary contact closure. Recommended “start pulse” is 500 milliseconds.

**CAUTION: VOLTAGE ACROSS THESE TERMINALS, SUPPLIED FROM THE SENSOR BOARD, IS 5 VDC. DO NOT PROVIDE EXTERNAL POWER TO THE INHIBIT AND MEASURE TERMINALS. PROVIDE A DRY CONTACT ONLY**

**Figure 4. Single Unit-To-Remote Display Wiring (with additional sensors) (Units built after October 2003)**

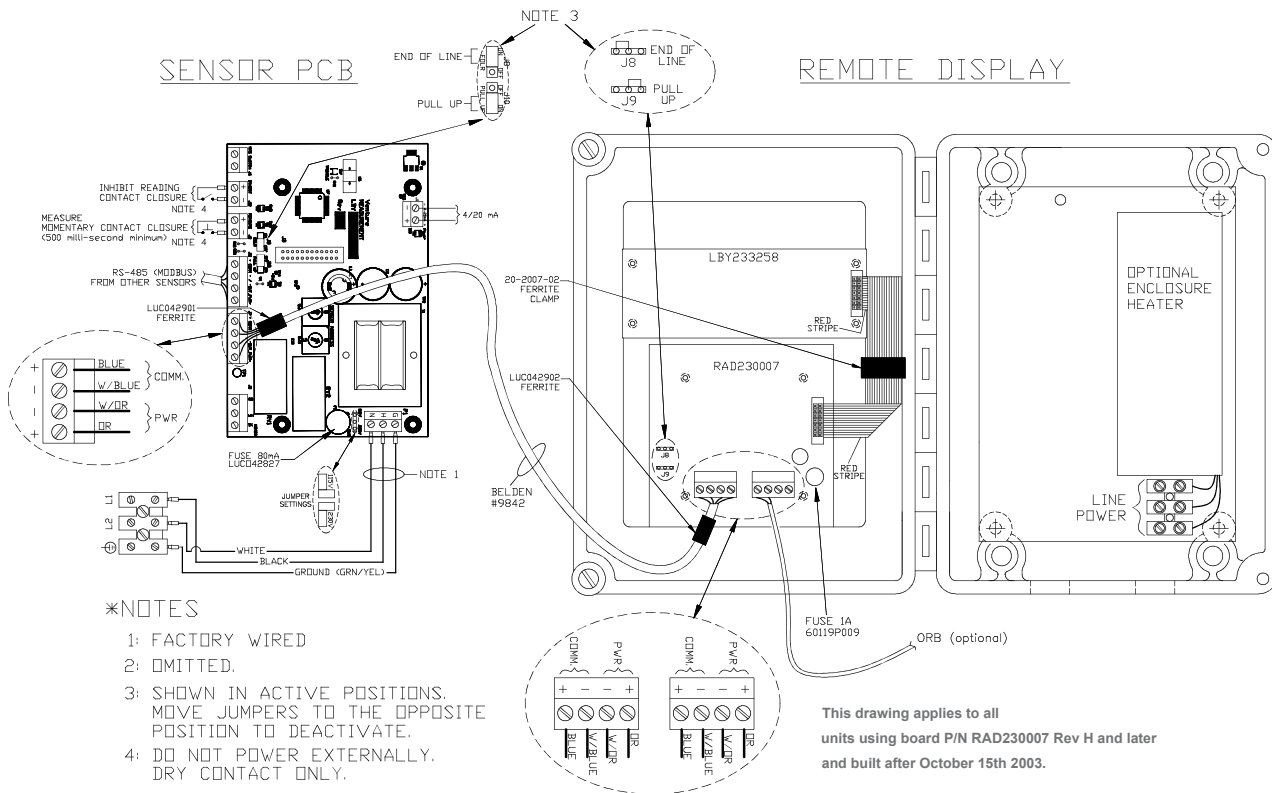

## VI. SET UP

### LINES OF DISPLAY

Line	Description
Top	Sensor address and name
Second	Measurement in units selected and percentage full or empty
Third	Display mode
Fourth	Status of the displayed sensor

S	e	n	s	o	r		2	5		H	D		P	o	l	y	m	e	r			
1	2	3	4	5	6	7	L	b	s													
							M	A	T	R	I	A	L		M	O	D	E				
							S	E	N	S	O	R		I	S		N	O	R	M	A	L



### OPERATING MODE FUNCTIONS

Button	Function
Left/Right Arrow	Used to scroll through the Yo-Yo being modified or programmed; max. number of units is 99
Measure	Take an immediate manual measurement

### PROGRAM MODE FUNCTIONS

Button	Function
Arrows	Use to scroll through menu or move cursor to desired location
Enter	Accept displayed value
ESC	Push to go back to previous menu; to get to Main Menu – continue to push until it is reached on the screen
Program	Push to start set-up of unit

It is recommended that the following characteristics are determined before the start of programming. The chart below can be used for reference, add more columns as necessary. Definitions and requirements for each Function are listed below.

Sensor Address						
Sensor Name						
Units (Check one per sensor)	Distance	Feet				
		Meters				
	Engineering	Cubic Feet				
		Cubic Meters				
		Pounds				
		Kilograms				
		Gallons				
Liters						
Parameters	Tank Height					
	Full Distance					
	Empty Distance					
	Max. Move Distance					
	Cone Height					
	Full Scale Value					
	Auto Timer On/Off					
	Timer Setting in Mins.					
	Air Space or Material Mode					
	20 mA Full or 20 mA Empty					
Jumper Settings	End Of Line Resistor					
	Pull-Up Resistor					

Figure 5. Tank Parameters Reference

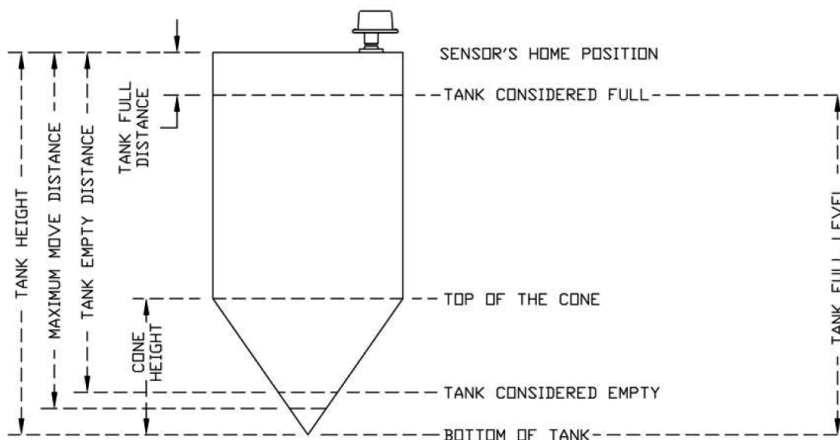

**Note:** While in Programming Mode, no information is transferred between the remote display and the other Yo-Yo sensors; for this reason there is an automatic timeout period. If no keys are pressed for one minute, the remote display will exit the Programming Mode without saving changes and return to the Operating Mode.



## TO PROGRAM A SENSOR

1. Press left/right arrow keys in Operating Mode section of the key pad to move to the desired sensor address. Holding a key down will scroll through the sensors quickly.

**Note:** One sensor must have an address of 01 or unit will not communicate with the system.

2. Push Program on the key pad.
3. Enter the password. Password is 1936 – the system does not allow changes to the password at this time.
4. Press ENTER.
5. Use the arrow buttons to place the asterisk (\*) beside the desired selection and press ENTER. To move back press ESC.

**Note:** After one minute, unit will revert back to previous settings; can be used if mistake has been made to reset.

**Note:** For a multiple sensor system, all sensors need to be enabled individually.

## SETTINGS MENU

- Set Units
  - Units
  - Distance Units
  - Engineering Units
- Set Tank Parameters
  - Tank Height
  - Tank Full Distance
  - Tank Empty Distance
  - Maximum Move Distance
  - Cone Height
  - Full Scale Value
- Display Mode
  - Material
  - Air
- Set 4-20 mA Mode
- Set Autotimer Mode
  - Autotimer Time
- Set Sensor Name
- En(able) /Disable Sensors
- Save & Quit

## **TAKING A MEASUREMENT**

Multiple methods can be used to take a measurement with the Yo-Yo, automatically or manually. The Yo-Yo level sensor also has the ability to offer a variety of remote measurement options.

### **USING THE REMOTE DISPLAY (IMMEDIATE MEASURE)**

The Remote Display is capable of monitoring up to 99 sensors.

1. Press left/right arrow keys in Operating Mode section of the key pad to move to the desired sensor address. Holding a key down will scroll through the sensors quickly.
2. Press the Measure key in the Operating Mode section of the key pad. The initial indication should read “Starting Measure” followed by “Sensor is Measuring”
3. When the measurement is complete, the reading will be updated. Status should read “Sensor is Normal”.

### **AUTO-TIMER MEASUREMENT**

Please use caution when using this feature; sending the sensing weight to the material surface should not be done while the vessel is filling. It is strongly recommended to use the Inhibit Feature when Auto-timer is on. See Electrical Section for details.

1. Press left/right arrow keys in Operating Mode section of the key pad to move to the desired sensor address. Holding a key down will scroll through the sensors quickly.
2. Push Program on the key pad.
3. Enter the password. Password is 1936 (The system does not allow changes to the password at this time.)
4. Press ENTER.
5. Use the arrow buttons to place the asterisk (\*) beside ‘Set Auto-timer Mode’ and press ENTER.
6. Use arrows to set time (duration period can range from from once every 2 minutes to 9999 minutes (approximately 1 week).
7. Press ENTER. The Yo-Yo will now automatically take measurements as requested.

## USING THE ORB

1. Device should be wired to the ORB; see Electrical Section.
2. Login to the ORB normally. NOTE: User permissions have to be set to allow for measurements; see ORB Installation & Operator Manual for detail to change individual permissions.
3. Locate the desired silo on home page screen.
4. Click 'Measure'

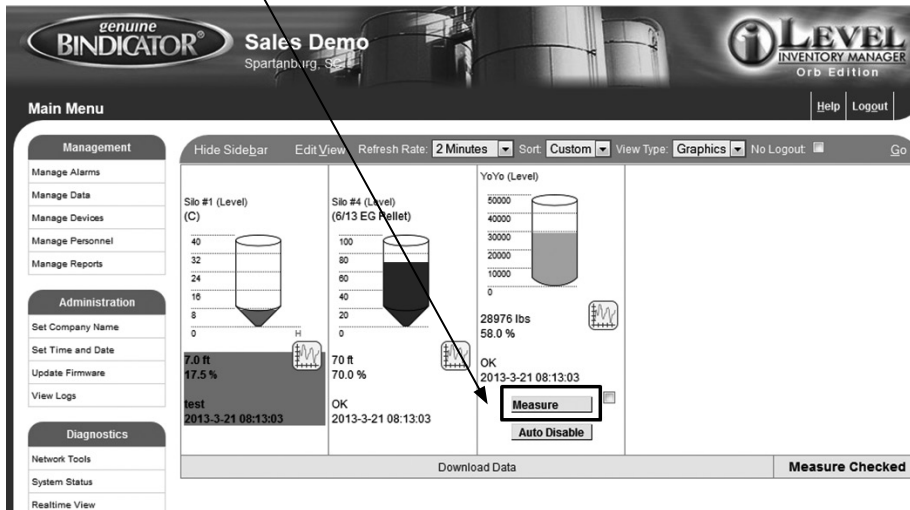

## USING A PLC

1. Device should be wired to accept PLC communication; see Electrical Section.
2. Reference the Modbus to Yo-Yo Guide (Part Number LBY180113) for commands.

## DEFINITIONS & MENU DESCRIPTIONS

### SET UNITS

- UNITS

This item determines if the sensor will display linear distance units in feet or meters, or in engineering units (volume/weight). If English units are selected on this menu, all tank definition distances will be edited using feet. If metric units are selected, all distances will be edited using meters.

When engineering units are selected in conjunction with a cone height greater than 0, the displayed value and the 4-20 mA output are linearized. This linearization assumes a center discharge cone below a round, straight sidewall silo.

**Note:** When selecting any engineering unit, the Full Scale Value (the amount of material that corresponds to the Tank Full Distance) must also be specified.

#### Distance Units

Feet (Default is one decimal place.)

Meters (Default is two decimal places.)

#### Engineering Units (Default is no decimal places.)

Pounds

Kilograms

Gallons

Liters

## TANK PARAMETERS

This menu defines the tank dimensions. All distances except Cone Height are taken from the home position of the sensor. The firmware allows the user to enter only the following possibilities:

Tank Height  $\geq$  Maximum Move Distance  $\geq$  Tank Empty Distance

Tank Empty Distance  $>$  Tank Full Distance  $\geq 0$

Tank Height  $>$  Cone Height  $\geq 0$

Maximum Move Distance  $\geq$  (Tank Height/2)

- TANK HEIGHT

This parameter is the distance from the GP-4 Yo-Yo sensor home position to the bottom of the tank. The default value is 75 ft. (22.86 m) and the range is from 3.3 ft. (1 m) to 199.9 ft. (60.93 m).

**Note: Standard cable length is 100 ft. (30.48 m). DO NOT program a value greater than this length unless a special storage wheel with an extended length of cable has been provided with the sensor.**

The tank height value must be greater than or equal to the Maximum Move Distance and Tank Empty Distance. Therefore, setting this value to less than 75 ft. (22.86 m) will automatically reduce the value of the Tank Empty Distance and Maximum Move Distance to the same value.

- TANK FULL DISTANCE

This parameter is the distance from the GP-4 Yo-Yo sensor home position to the level of material where the tank is considered full. This parameter also determines the 20 mA output point when 20 mA represents a “full” vessel. If 20 mA represents an empty vessel, the Tank Full Distance is also setting the 4 mA point. The default value for the Tank Full Distance is 0. The range is from 0 ft. (0 m) to 1,999.9 ft. (60.93 m).

- TANK EMPTY DISTANCE

This parameter is the distance from the GP-4 Yo-Yo sensor home position to the point where the tank is considered empty. This parameter normally determines the 4 mA output. The default value is 75 ft. (22.86 m) and the range is from half of the Tank Height parameter to 199.9 ft. (60.93 m).

- MAXIMUM MOVE DISTANCE

This parameter is the maximum travel distance from the GP-4 Yo-Yo sensor home position. This parameter is used to limit the sensor from traveling through the discharge of the tank or into discharge equipment such as screw conveyors. When the GP-4 Yo-Yo sensor reaches this travel distance it will

stop the measurement, retract the weight, and display MAXMOVE DIST REACHED. It will also display the distance traveled. The default value of this parameter is 75 ft. (22.86 m) and the range is from the Tank Empty Distance to 199.9 ft. (60.93 m). The Maximum Move Distance value must be less than or equal to the Tank Height value.

- **CONE HEIGHT**

This parameter is only used when engineering units has been selected in the Units menu. It is used to calculate the volume of material in the cone of a center fill, center discharge, round vessel. It is the distance from the bottom of the tank to the top of the cone. The default value is 0 ft. (0 m) and the range is from 0 ft. (0 m) to 199.9 ft. (60.93 m).

- **FULL SCALE VALUE**

This entry is shown only if “engineering units” has been selected in the Units menu. It is the maximum (full) tank weight or volume capacity of the tank from the bottom of the tank to the level where the tank is considered full (See Tank Full Distance in Figure 5.3). The default value is 1 and the range is from 1 to 9,999,999.

- **AUTOTIMER TIME**

This entry is shown only if Autotime Mode is set to ON. This parameter selects the amount of time between automatic cycle requests. The default setting is 1,440 minutes (24 hours). Select a value of 2 minutes to 9,999 minutes (approximately 1 week).

**Note: The motor has a 50% duty cycle. DO NOT run the GP-4 Yo-Yo sensor continuously.**

## **DISPLAY MODES**

- **MATERIAL**

If feet or meters have been selected in the Units menu, the display shows the level of material in the tank. This is the distance from the bottom of the tank to the top of the material. When engineering units are selected in the Units menu, the display shows the weight or volume of material in the vessel. When using the 4-20 mA output, the range is defined as the points between the “Tank Empty Distance” and the “Tank Full Distance”. Material Mode is the default setting. Mathematically: Level Material Mode = Tank Height - Measured Level.

- **AIR**

Insert If feet or meters have been selected in the Units menu, the display will show the distance to the material less the Tank Full Distance value (See Figure 5.4). For example, if the material in the tank is 10 ft. (3.048 m) from the GP-4 Yo-Yo sensor home position and the Tank Full Distance is 0, the display will show 10 ft. (3.048 m). In the same scenario, with the Tank Full Distance set to 3 ft. (0.91 m), the display will now show 8 ft. (2.44 m).

The same rules apply is engineering units is selected in the Units menu. When volumetric or mass units have been selected, the display will indicate the volume or weight available (outage) in the vessel from the Tank Full Distance point. Only the unit of measurement changes.

## 4-20 mA MODE

This parameter is selected independent of the Material Mode or Air Mode. Typically, when the display is programmed for Material Mode, 20 mA will also represent a full tank. Inversely, when displaying in Air Mode, 20 mA will be set to represent an empty tank. However, both functions can be independently reversed if desired.

**Note: If engineering units has been selected in the Units menu and a Cone Height greater than 0 has been specified, the 4-20 mA output will be linearized for the cone section.**

If power is in initial start-up or has been lost and restored, the 4-20 mA output will indicate greater than or equal to a full tank. The actual output could be greater than or equal to 20 mA or less than or equal to 4 mA depending on the selected mode. When a new reading is requested and the cycle is completed within the set tank parameters, a new value (typically between 4 mA and 20 mA) will be produced. Once updated, the Yo-Yo sensor will hold the 4-20 mA value until cycled again.

20 mA = Full (Default)

20 mA = Empty

## AUTO-TIMER MODE

When the Auto-timer Mode is set to ON, the Yo-Yo sensor is able to take a reading automatically at an interval defined in the Auto-timer Time menu. When the Auto-timer Mode is set to OFF, the Yo-Yo sensor will only begin a measurement when manually requested. It is strongly recommended that the inhibit feature is utilized when using the Auto-timer Mode.

ON

OFF (Default)

## SET SENSOR NAME

Name can be up to ten (10) characters; Characters may include the following: A, B, C, D, E, F, G, H, I, J, K, L, M, N, O, P, Q, R, S, T, U, V, W, X, Y, Z, [, \, ], ^, \_, a, b, c, d, e, f, g, h, i, j, k, l, m, n, o, p, q, r, s, t, u, v, w, x, y, z, {, }, Space, !, ", #, \$, %, &, ' , (, ), \*, +, Comma, -, ., /, 0, 1, 2, 3, 4, 5, 6, 7, 8, 9, :, <, +, >, ?, @

## ENABLE/DISABLE SENSORS

All disabled sensors can be enabled or disabled from any active (enabled) sensor address. In a new system, the readout will look for sensor address #01. Addressing is done via an 8-position DIP switch on each sensor. Other sensors can be enabled from that address. Sensor enable/disable status is stored in EEPROM at the display. Sensors do not have to sequentially addressed.

## SAVE AND QUIT

This entry downloads all parameter additions or changes from the display to the selected sensor. All sensor configuration information is stored in EEPROM on board each sensor. Enabled/disabled sensor information is stored in the display.

## VII. MAINTENANCE

### PREVENTIVE

Bindicator does not provide a preventative maintenance schedule for the Yo-Yo Inventory Management System. The interval for preventative maintenance depends on the application of the sensor and how often it is cycled. However, the following checks are recommended.

1. Inspect the inside of the sensor enclosure. Check the mechanical side for excessive coating on the cable or in the enclosure. Clean if necessary. If the problem continues or if dirt and debris are present on the electrical side of the sensor, install a low-pressure air purge on the sensor. A 0.25 in. NPT fitting is provided.
2. Inspect the weight and cable. If there is excessive wear on the cable, the cable may be rubbing on a sharp edge of the nozzle or the entry into the tank.
3. Be sure the weight is securely attached to the cable. If a bottle-style weight is used, ensure that there are no leaks and that the overall weight is between 20 ounces and 25 ounces.
4. Check that all wheels and arms move freely, particularly the count wheel.

### REPLACEMENT PARTS

PART NUMBER	DESCRIPTION		
		LUC039209	Per Foot, Belden #9842 (2-pair, AWG 24)
LBY211182	Plastic Bottle Weight (Poly)	LUC039210	500 ft (152.4 m) Roll, Belden #9842 (2-pair, AWG 24)
LBY211188	Stainless Steel Bob Weight (Poly)	LUC039211	1,000 ft (304.8 m) Roll, Belden #9842 (2-pair, AWG 24)
LBY211384	PVC Jacketed Bob Weight (Includes 50 ft (15.24 m) of monofilament cable)	LBY211416	Sensing Arm Assembly with Wheel & Magnet
LBY211269	Plastic Spike Weight (Poly)	LBY233116	Gasket, Flange (Cover)
LBY211427	Stainless Steel Float	LBY233131	Gasket, Cover (Center Arm)
LBY211305	Low Density Plastic Weight	LHY233201	Gasket, Frame
LBY231290	Polyester Cable		
LBY231293	Monofilament Cable		
LBY233255	Replacement Sensor E/U (120VAC)		
LBY211453	Replacement Sensor E/U (240VAC)		
LUC042827	Fuse, Sensor PCBA 80 mA TR5 Case		
60119P009	Fuse, Display/Driver Board, 1A		
RAD230007	Replacement Display Driver Board		
LBY233258	Replacement LCD Display Board		
LBY211451	GP-4 Motor Assembly (120 VAC)		
LBY211452	GP-4 Motor Assembly (240 VAC)		
LHY211581	Mark-4 Motor Assembly (120 VAC)		
LHY211582	Mark-4 Motor Assembly (240 VAC)		

Please consult with factory if unsure of parts required.  
Not all parts fit all models.

## VIII. TROUBLESHOOTING

When troubleshooting the Yo-Yo Inventory Management System, confirm that all power and communications wiring between the sensor and the remote display or PC are correct. If troubleshooting the sensor outdoors, shield the opto-reader from direct sunlight whenever the cover is removed. Always check the display status message on the remote display.

PROBLEM	SOLUTION
The reading always indicates a full vessel when a measurement is requested.	The sensor is short cycling. Inspect the sensor for the following possible problems: verify the sensor weight is 20 to 25 ounces, check that the weight is not stuck in the home position (possibly due to material build-up), check that the count wheel is free to move through the opto-reader, and check that the motor heater is operational (if the ambient temperature is below 32° F (0° C).
The remote display is blank.	Power to the display is fed from the sensor(s). First check that power is supplied to the sensor(s). Next, check the fuse on the display driver board (1A). If this is a single sensor system and power is present at the sensor, also check the sensor fuse (5A).
The sensor cycles normally, but the displayed value reads “0” or “1”.	The sensor may be set to engineering units in the Units menu, but the Full Scale Value has not been changed from its default value of 1. Set the Full Scale Value to a valid number.
A reading was requested once, but the sensor travels down to the surface multiple times.	If the sensor is programmed to take automatic readings, the sensor may be taking a timed reading following the manual request. If the number of counts up and down does not agree, the sensor automatically takes another reading. The sensor will send the weight to the material surface three times before displaying
Up/Down Do not match.	Check that the count wheel is moving freely and that the cable is not slipping. Check that the Maximum Move Distance is not greater than the length of cable available on the sensor. The cable should be running off of the storage wheel and rewinding backwards.
The sensor does not respond when a measurement is requested.	<p>Check to make sure that the sensor is properly addressed. Check the display. The status should read “Starting Measure” followed by “Sensor is Measuring”. If the status does not change, check the sensor fuse. If a different status message appears, see chart below. Jumper pins on Measure Terminal to test the cycle in the board.</p> <p>If all electrical functions are performing properly, check to see if the nut for the spring of the cable wrap needs to be loosened.</p>



<b>STATUS MESSAGE</b>	<b>DESCRIPTION</b>
SENSOR IS NORMAL	Sensor is normal.
STARTING MEASURE	Sensor is starting measurement. A command has been sent to the sensor to start a measurement and the sensor is ensuring that the weight is in the home position.
SENSOR IS MEASURING	Sensor is taking a measurement.
PERFORMING TEST	Sensor is performing a 4-20 mA test.
INHIBITED TO MEASURE	Sensor measurement is inhibited.
MAXMOVE DIST REACHED	Sensor has reached the "max move distance" without contacting material in the tank.
UP/DOWN DO NOT MATCH	"Up" counts and "Down" measurements do not agree.
LOST WEIGHT	Weight is missing or no weight is on the cable.
STUCK WEIGHT	Weight is stuck.
INVALID REPLY	Communication trouble or invalid reply.
4-20 mA CONFIG ERROR	Error in the configuration of the 4-20 mA output.
INVALID ERROR CODE	The error code received by the display is wrong.
OVRFLOW	If measurement is greater than 9,999,999 engineering units (or 100m if set in meters or 200 ft. if set in feet), this message will be shown instead of level, weight, or volume.
UNIT ERROR	If the unit of measurement received by the display is wrong, this message will be shown instead of level and units.
%ERROR	If the percentage received by the display is wrong, this message will be shown instead of the percentage.
ERROR IN MAT/AIR MOD	If the display mode received by the display is wrong, this message will be shown instead of the display mode.

Please note that the first three items in this list are not errors, but sensor status reports only. The remaining items are actual errors. For obvious reasons, some errors overlay other errors. For example, a sensor without communications cannot report its status.

## IX. DIMENSIONAL DRAWINGS

### Mark-4 Yo-Yo

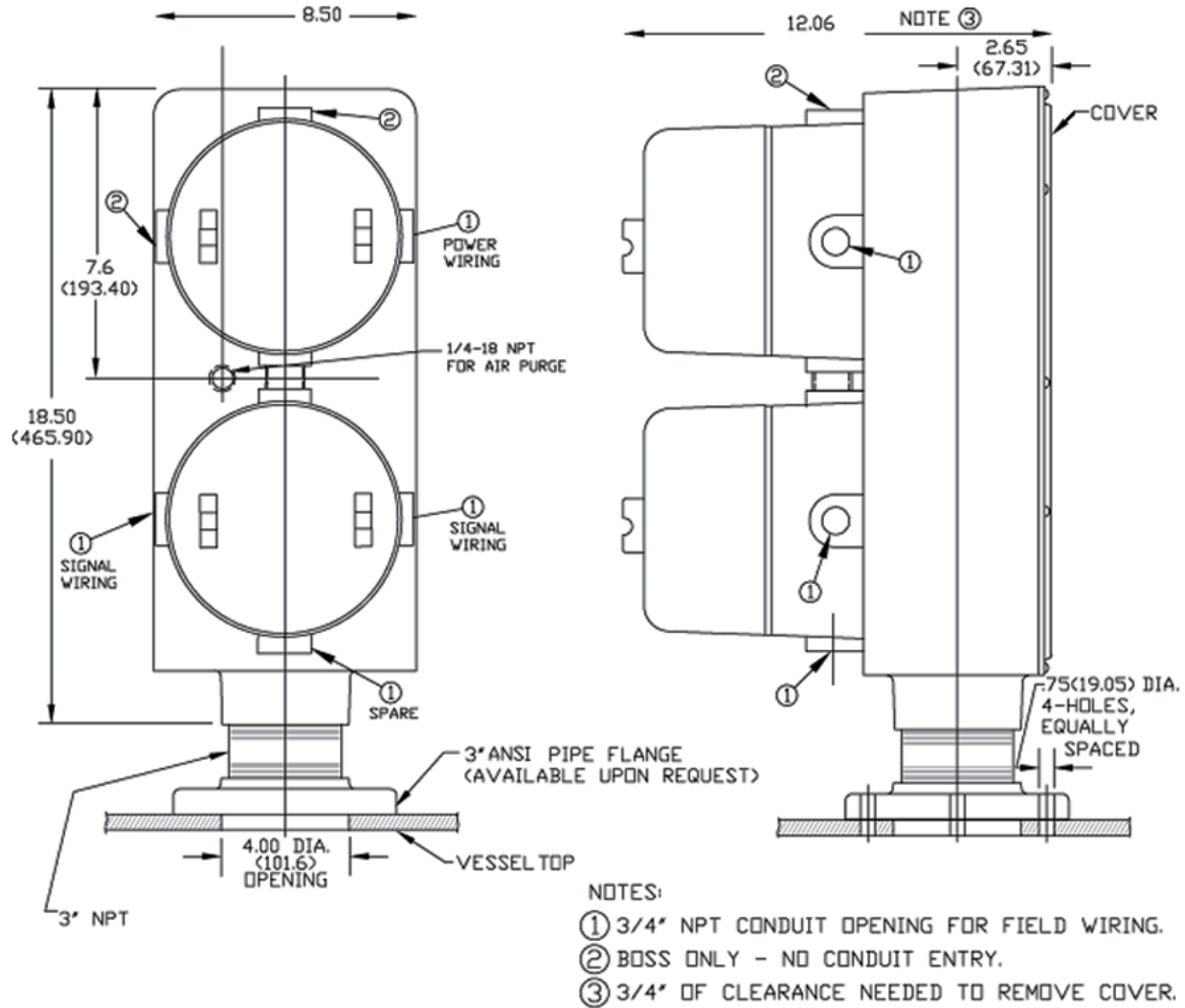

GP-4 Yo-Yo

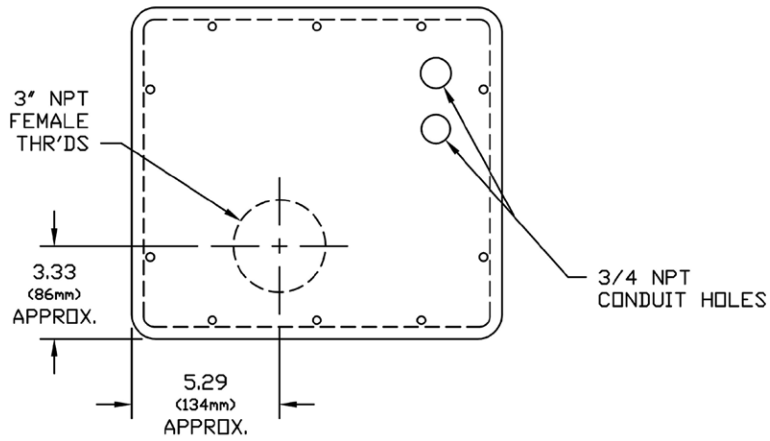
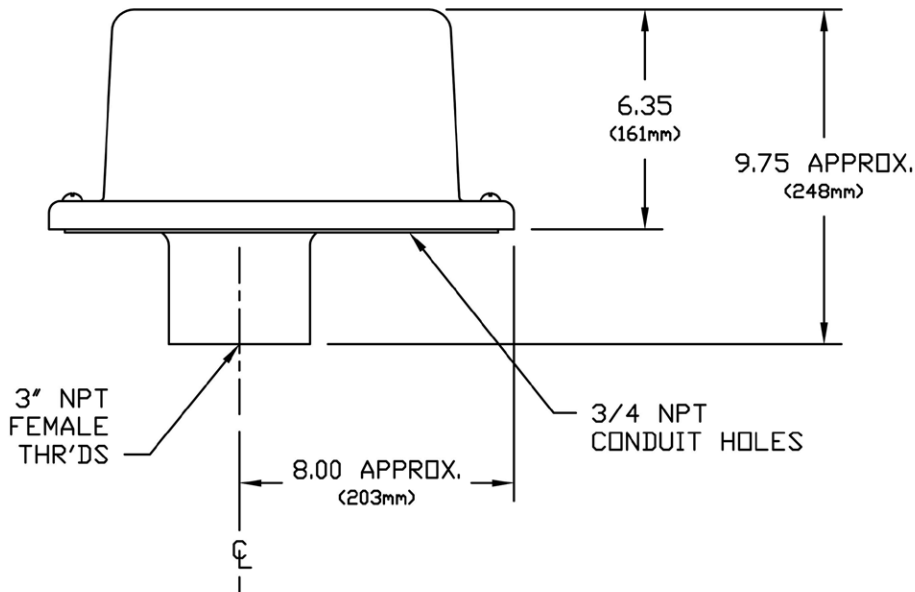
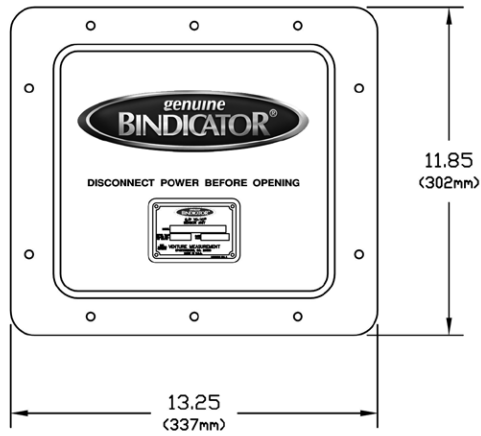

### Display Programmer Dimensions

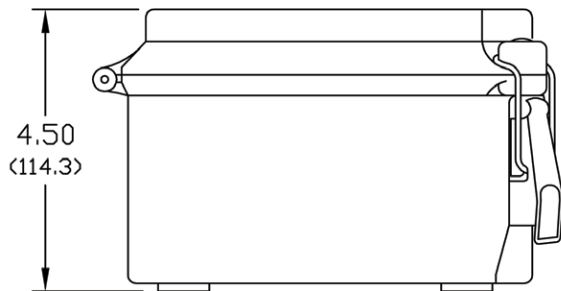
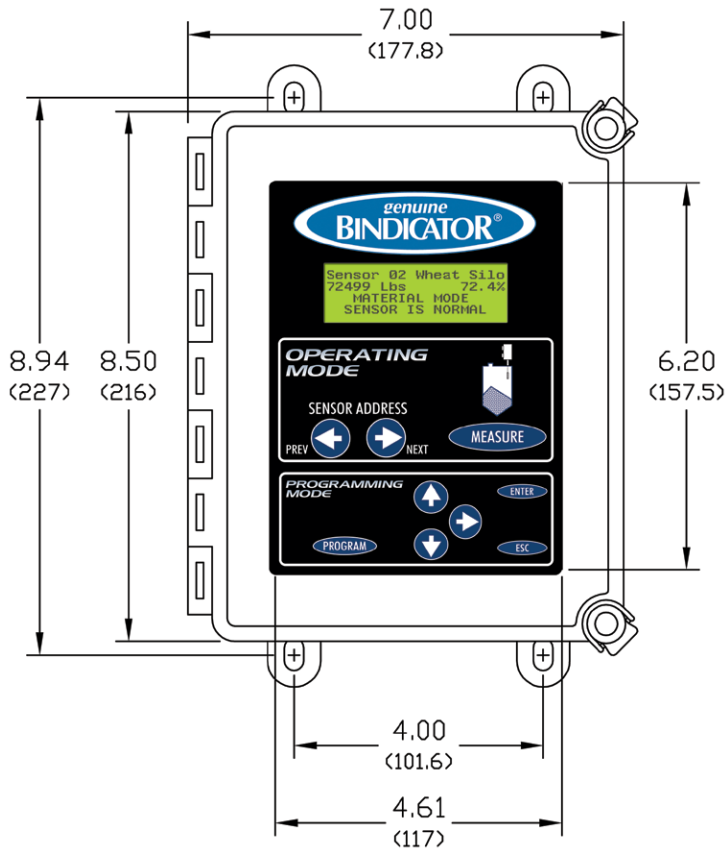

**Low Density Plastic Weight**

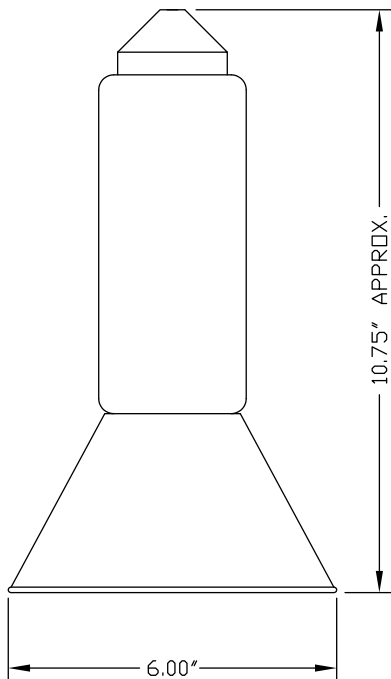

**Low Density Stainless Steel**

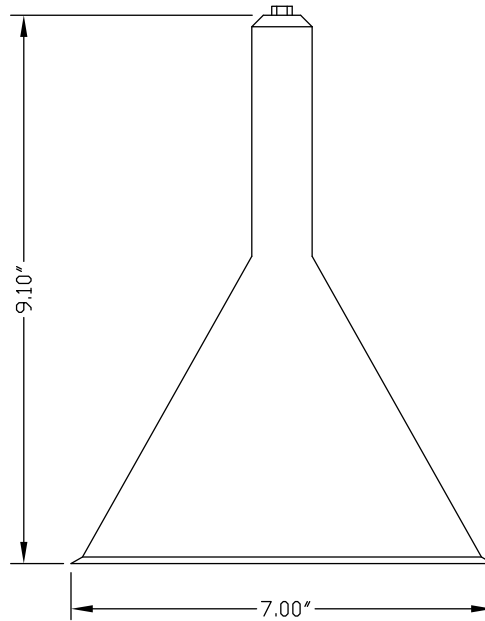

**Plastic Spike Weight**

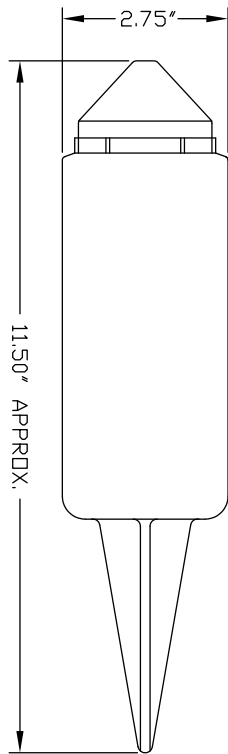

**Plastic Weight Standard**

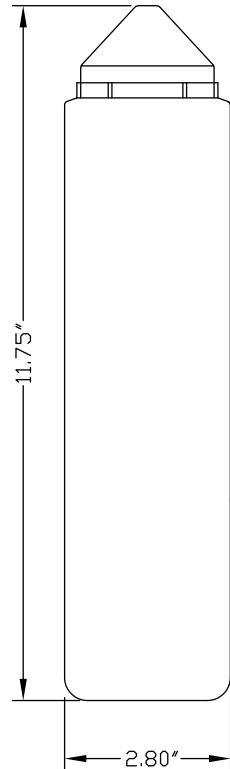

**Stainless Steel Float**

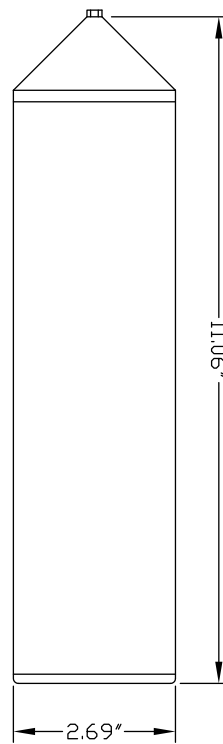

**PVC Jacketed Bob**

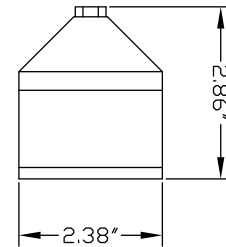

**Stainless Steel Bob**

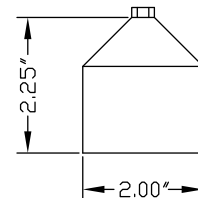

### GP-4 Cable Wrap Guide

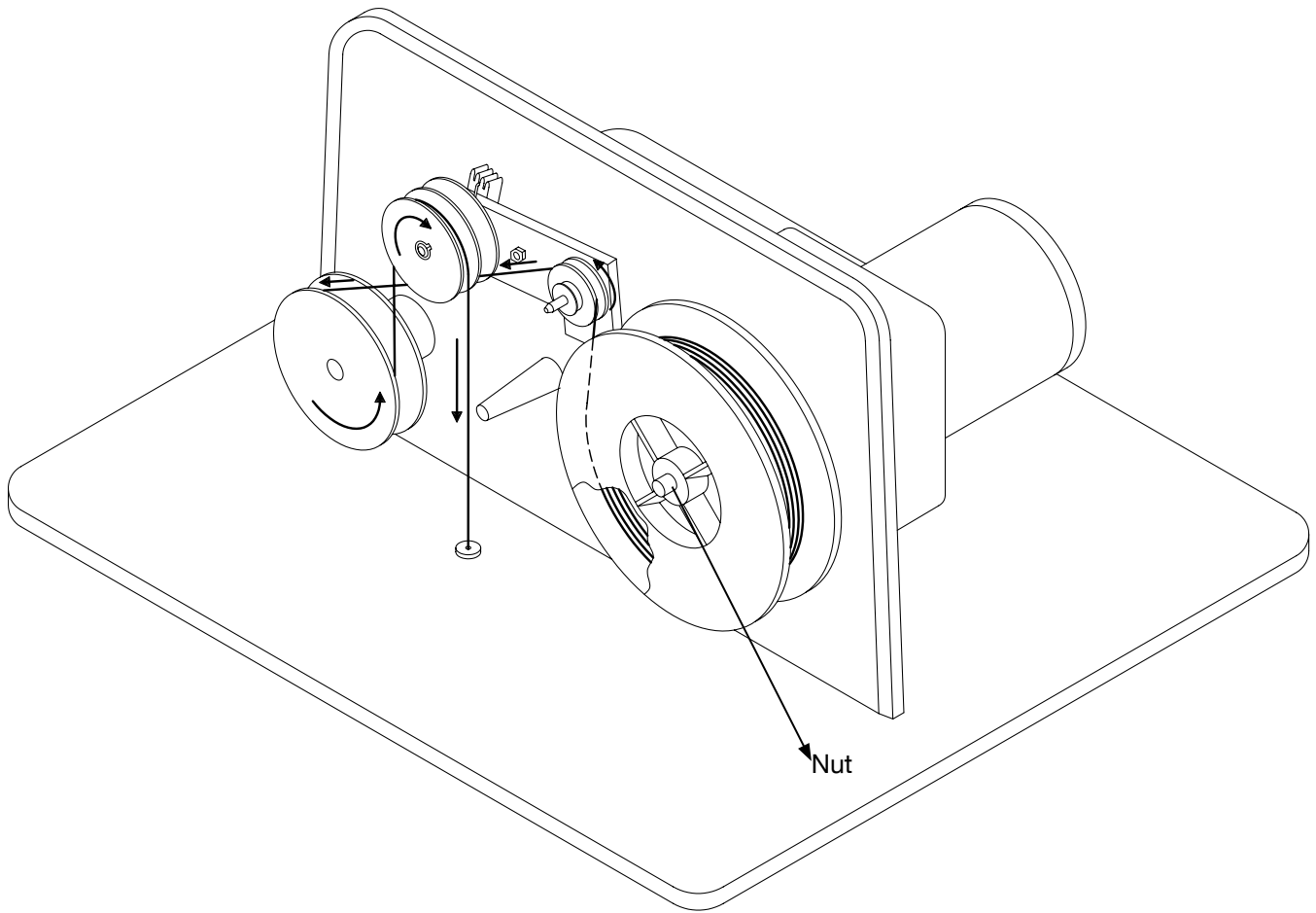

### Mark-4 Cable Wrap Guide

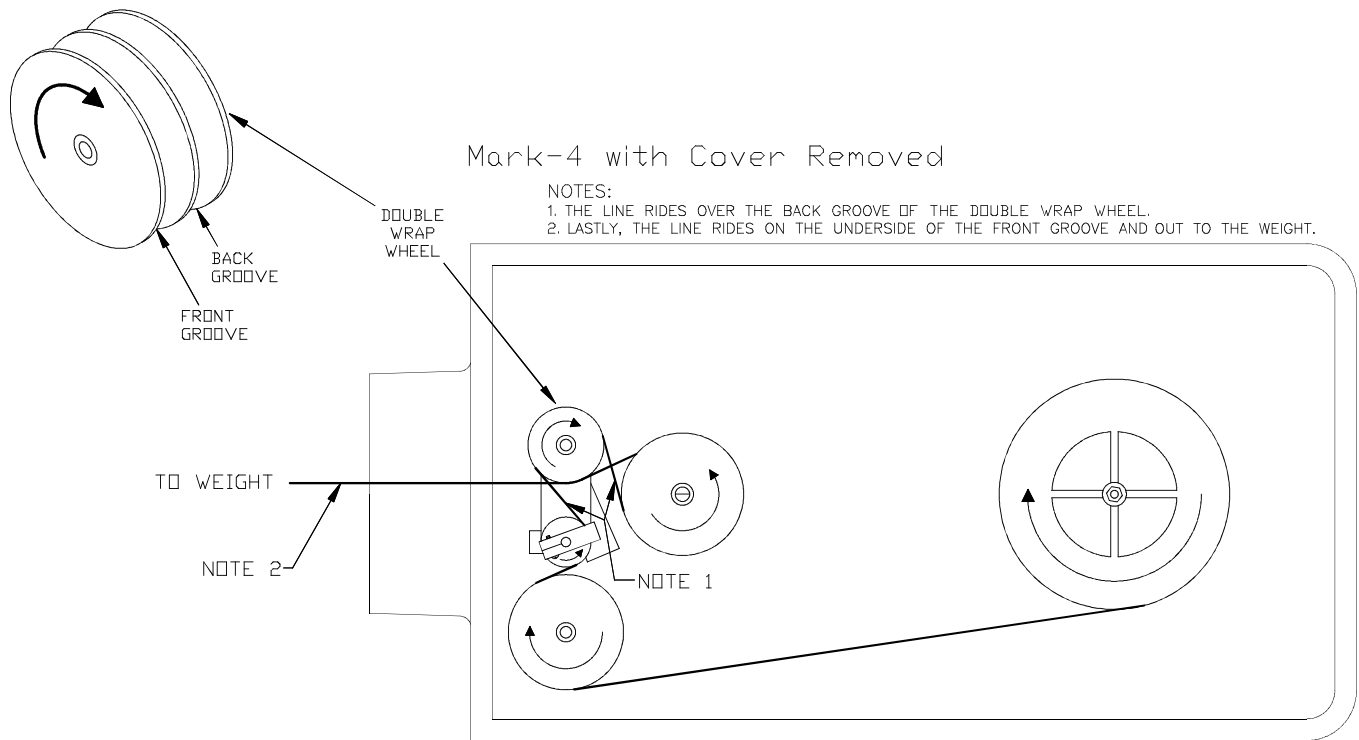



150 Venture Boulevard  
Spartanburg, SC 29306  
Tel: (800) 778-9242  
Fax: (864) 574-8063  
sales@bindicator.com  
www.bindicator.com

**venture**  
MEASUREMENT

2013 All rights reserved.  
All data subject to change without notice.

LBY180112 Rev. B