



Mini-Roto™ Paddle Wheel Installation & Operation Manual

Order from: **C A Briggs Company**

622 Mary Street; Suite 101; Warminster, PA 18974

Phone: 267-673-8117 - Fax: 267-673-8118

Sales@cabriggs.com - www.cabriggs.com



Mini-Roto™ Paddle Wheel Installation & Operation Manual

CONTENTS

I.	HANDLING & STORAGE.....	1
	Inspection and Handling	
	Disposal and Recycling	
	Storage	
II.	GENERAL SAFETY.....	2
	Authorized Personnel	
	Use	
	Misuse	
III.	PRODUCT DESCRIPTION	3
	Theory of Operation	
	Special Feature	
IV.	MECHANICAL INSTALLATION	4
	Location and Installation	
	Mounting Surface Preparation	
V.	ELECTRICAL INSTALLATION.....	5
	Field Wiring	
	Figure 1: AC Circuit Board	
	Figure 2: DC Circuit Board	

SAFETY SYMBOLS



WARNING:

IDENTIFIES CONDITIONS OR PROCEDURES, WHICH IF NOT FOLLOWED, COULD RESULT IN SERIOUS INJURY. RISK OF ELECTRICAL SHOCK.



CAUTION:

IDENTIFIES CONDITIONS OR PROCEDURES, WHICH IF NOT FOLLOWED, COULD RESULT IN SERIOUS DAMAGE OR FAILURE OF THE EQUIPMENT.

Mini-Roto™ Paddle Wheel

I. HANDLING AND STORAGE

SAVE THESE INSTRUCTIONS

INSPECTION AND HANDLING

Do not dispose of the carton or packing materials.

Each package should be inspected upon receipt for damage that may have occurred due to mishandling during shipping. If the unit is received damaged, notify the carrier or the factory for instructions. Failure to do so may void your warranty. If you have any problems or questions, consult Bindicator® Customer Support at 1-800-778-9242.

DISPOSAL AND RECYCLING

This product can be recycled by specialized companies and must not be disposed of in a municipal collection site. If you do not have the means to dispose of properly, please contact Bindicator® for return and disposal instructions or options.

STORAGE

If the Mini-Roto is not scheduled for immediate installation following delivery, the following steps should be observed:

1. Following inspection, repackage the unit into its original packaging.
2. Select a clean dry site, free of vibration, shock and impact hazards.
3. If storage will be extended longer than 30 days, the unit must be stored at temperatures between -40 and 70° C in non-condensing atmosphere with humidity less than 85%.



CAUTION: DO NOT STORE A NON-POWERED UNIT OUTDOORS FOR A PROLONGED PERIOD.

II. GENERAL SAFETY

AUTHORIZED PERSONNEL

All instructions described in the document must be performed by authorized and qualified service personnel only. Before installing the unit, please read these instructions and familiarize yourself with the requirements and functions of the device. The required personal protective equipment must always be worn when servicing this device.

USE

The device is solely intended for use as described in this manual. Reliable operation is ensured only if the instrument is used according to the specifications described in this document. For safety and warranty reasons, use of accessory equipment not recommended by the manufacturer or modification of this device is explicitly forbidden. All servicing of this equipment must be performed by qualified service personnel only. This device should be mounted in locations where it will not be subject to tampering by unauthorized personnel.



WARNING: ALWAYS REMOVE POWER BEFORE SERVICING.

MISUSE

Improper use or installation of this device may cause the following:

- Personal injury or harm
- Application specific hazards such as vessel overfill
- Damage to the device or system

If any questions or problems arise during installation of this equipment, please contact the Bindicator® Customer Support at 800-778-9242.

III. PRODUCT DESCRIPTION

THEORY OF OPERATION

The Mini-Roto™ utilizes a low torque, slow speed permanent magnet synchronous motor and two micro switches.

During normal operation (no material present) the synchronous motor rotates the paddle at 1 RPM. When the paddle rotation is impeded by material surrounding it, the motor rotates and activates two micro switches. One switch is used to control the customer's equipment. The second switch will shut off the motor, illuminate the red Alarm LED and turn on the heater.

SPECIAL FEATURE

The inside lower frame houses a tension spring for torque adjustment. The units are shipped to our customers in high sensitivity for low bulk density materials. The spring should be moved to the next peg (peg furthest away from the motor assembly) for high bulk density material applications.



CAUTION: IF THE SPRING IS MOVED, ENSURE IT IS DIRECTED TOWARDS THE OUTSIDE OF THE PEGS. THIS WILL PREVENT THE SPRING FROM IMPEDING ON THE PIVOT OF THE MOTOR.

FUNCTIONAL

Operating Power	120/240 VAC, 24 VDC or 24 VAC
Motor Rating	Permanent-magnet synchronous, 2 watts
Switch Rating	SPDT 10A 125 VAC 10A 250 VAC ½ A 125 VDC ¼ A 250 VDC
Operating Temperature	-40° F (-40° C) to 200° F (93° C)

PHYSICAL

Drive Shaft Assembly	Precision machined shaft with two shielded ball bearings
Shaft Seal	Teflon®/Viton™ Lipseal™ rated ½ micron @ 30 psi (2.1 kg/cm²) @ 400° F (204° C)
Housing and Cover	Injection Molded Minlon®, corrosion resistant weatherproof (NEMA 4, 4X, 5)
Mounting	¾" NPT
Paddle	Nylon®, Ryton® or Polysulfone Injection Molded; Insertable, 4 Vane and 2 Vane (PVC only)
Shaft Extension	PVC or 304 Stainless Steel
Conduit Entry	½" NPT
Screw Terminals	For power and switch wiring
Shipping Weight	10 lb (4.5 kg)

IV. MECHANICAL INSTALLATION

LOCATION AND INSTALLATION

The paddle and shaft are to be kept out of the direct flow of material. If the Mini Roto-Bin-Dicator® is installed and contacts the flow stream, it is recommended that a protective baffle be installed on the inner wall.



CAUTION: WHEN SIDE MOUNTING, THE CONDUIT OPENING SHOULD BE PLACED DOWN TO ELIMINATE MOISTURE FROM ENTERING THE UNIT FROM THE CONDUIT.

MOUNTING SURFACE PREPARATION

On a 4^{3/4}" (120.65 mm) bolt circle, drill and/or tap 6 equally spaced holes in the bin wall for ^{3/16}" bolts or cap screws. Bolt heads should be tack welded to bin inner wall. Insert gasket between mounting plate and bin wall. Cut a ^{3/4}" diameter hole in order to insert 4-vane paddle. An insertable paddle will pass through a ^{3/4}" coupling at the bin wall.

V. ELECTRICAL INSTALLATION



WARNING: REMOVE POWER FROM THE UNIT BEFORE INSTALLING, REMOVING, OR MAKING ADJUSTMENTS.

GENERAL SAFETY

When using electrical equipment, you should always follow basic safety precautions, including the following:

- The installation and wiring of this product must comply with all national, federal, state, municipal, and local codes that apply.
- Do not modify any factory wiring. Connections should only be made to the terminals described in this section.

DISCONNECT REQUIREMENTS FOR PERMANENTLY INSTALLED EQUIPMENT

A dedicated disconnecting device (circuit breaker) must be provided for the proper installation of the unit. If independent circuits are used for power input and main relay outputs, individual disconnects are required.

Disconnects must meet the following requirements:

- Located in close proximity to the device
- Easily accessible to the operator
- Appropriately marked as the disconnect for the device and associated circuit
- Sized appropriately to the requirements of the protected circuit (See specifications)

CHASSIS GROUND

The input power ground lead must be connected to the chassis ground terminal provided. Wire sizes must be selected such that it can safely carry the sum total of all circuits' maximum amperage.

WIRING

Field wiring should conform to the requirements of the National Electrical Code and any other agency or authority having jurisdiction over the installation.

- Check nameplate for proper operating voltage
- Connect power wires to terminal block (TB-1) located on circuit board (See Figure 1)

Figure 1: AC Circuit Board

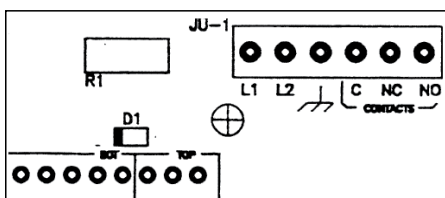
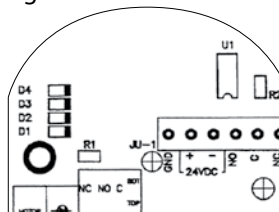

Figure 2: DC Circuit Board



- Connect wiring for alarm output to terminal block. (Diagram is also located in housing cover for position of terminal contacts)



CAUTION: AFTER WIRING CONNECTION ARE COMPLETE, VERIFY THAT THE WIRES AT CONDUIT ENTRY ARE NOT IMPEDING THE SWITCHES FROM ACTUATING.

Top View of Mini Roto

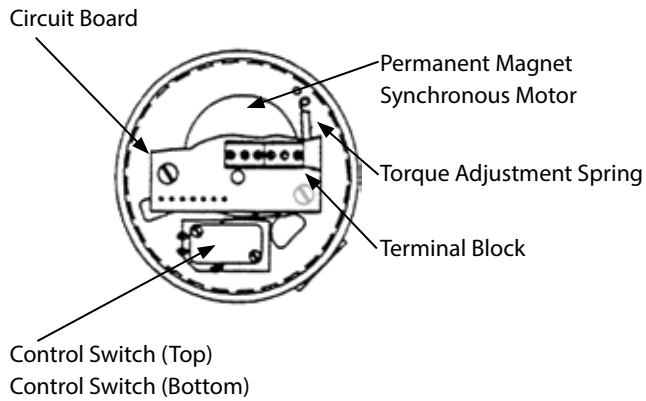

Side Cut-away View of Mini Roto

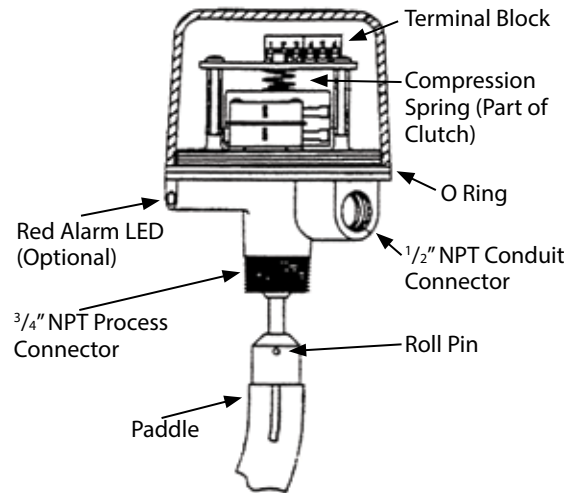

Mounting Plate & 4 Vane Paddle

6 holes .22" (5.5 mm) die equally spaced on a 4.75" (120.65 mm) bolt circle

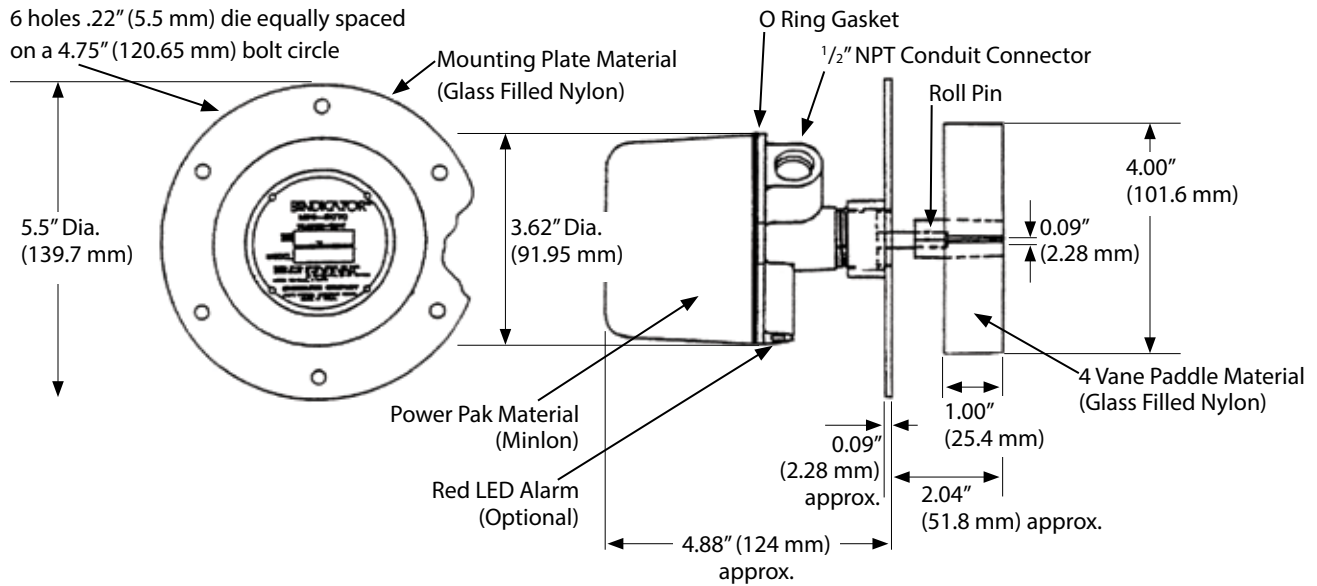

Insertable Paddle

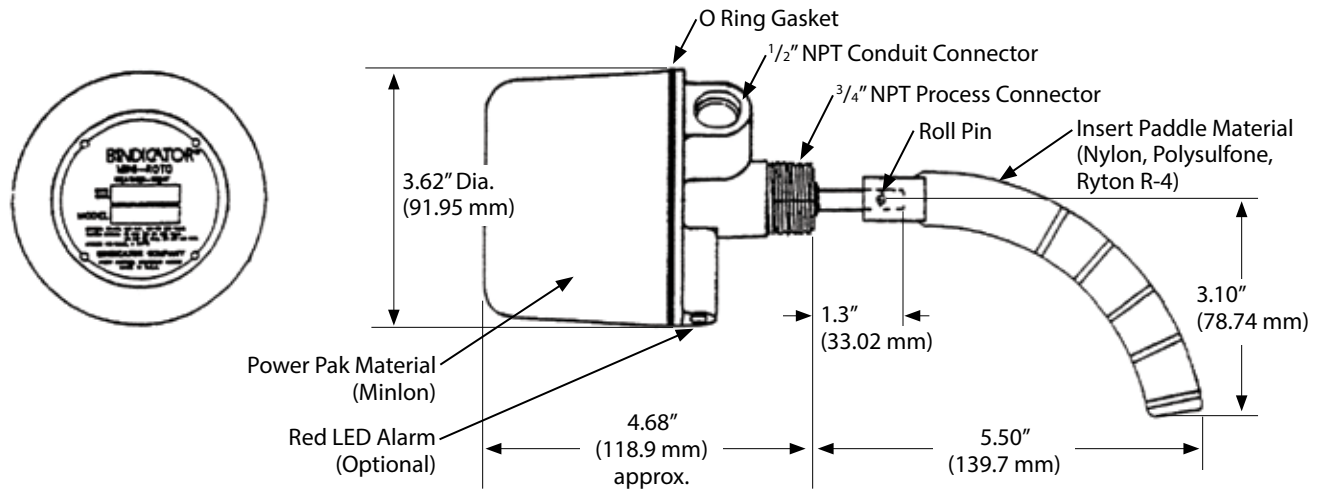

4 Vane Paddle with Shaft & Guard Extension

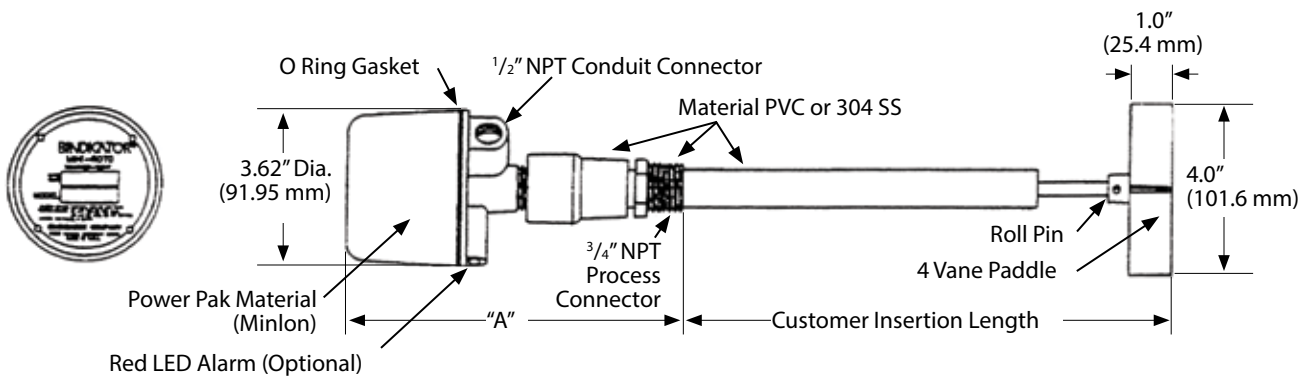

"A" Dimensions

PVC Version	7.56 (192)	LG
SS Version	7.38 (187.45)	LG

4 Vane Paddle with Shaft & Guard Extension

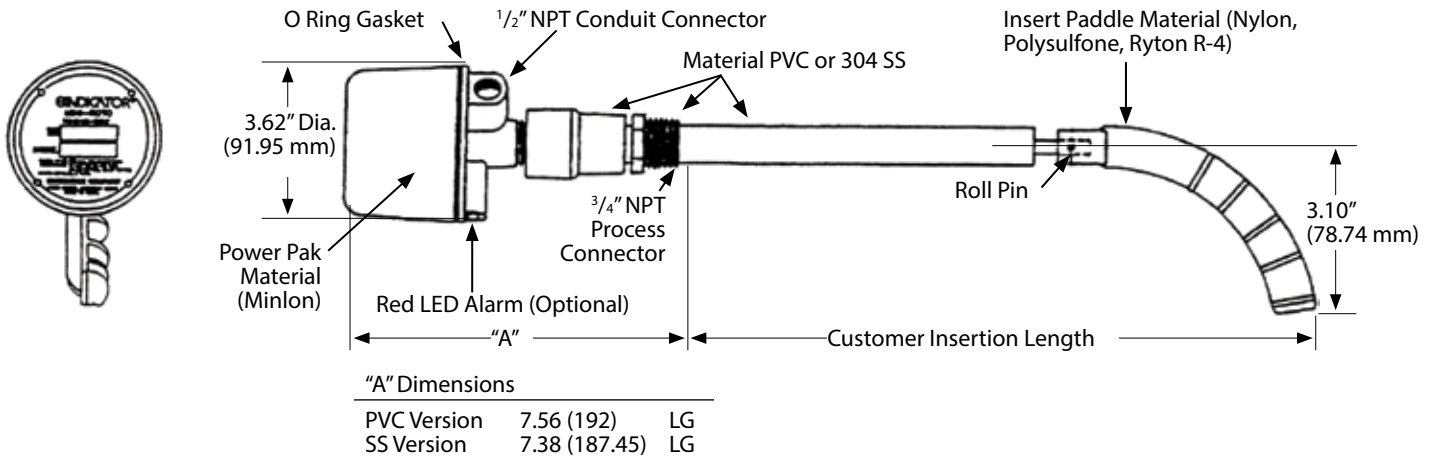

4 Vane Paddle with Shaft & Guard Extension

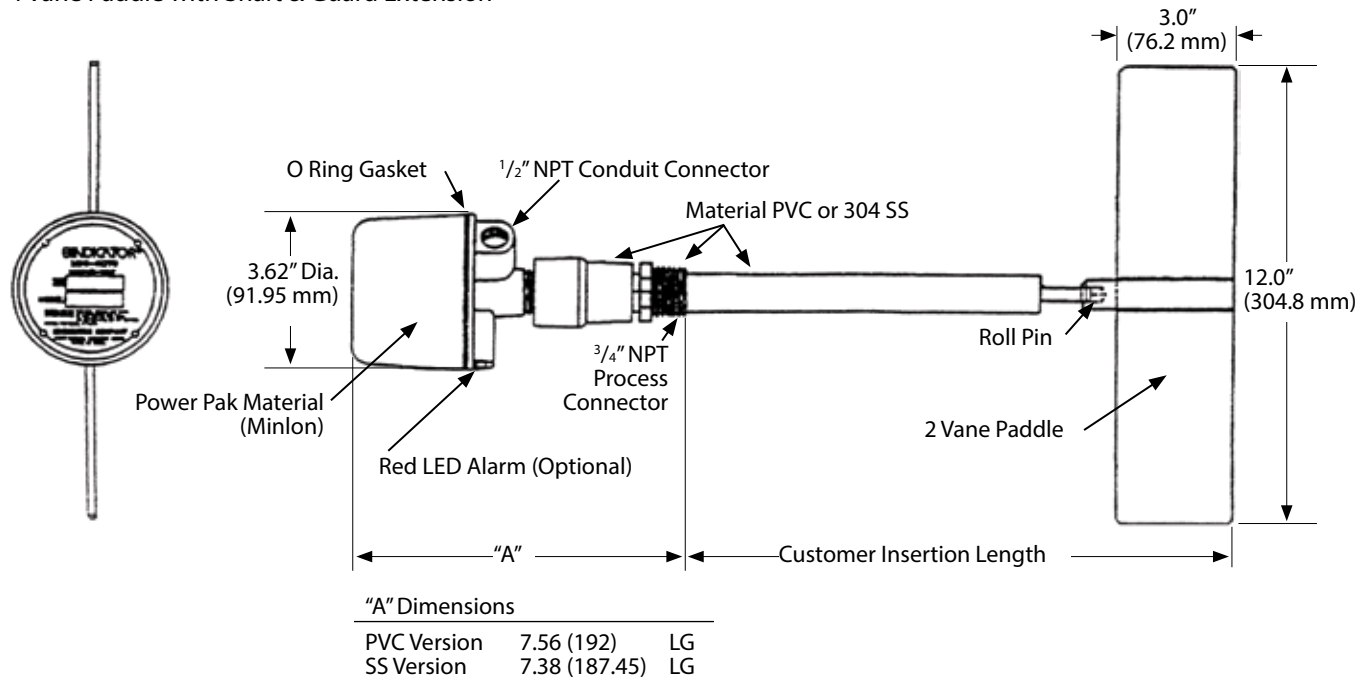

150 Venture Boulevard
 Spartanburg, SC 29306
 Tel: (800) 778-9242
 Fax: (864) 574-8063
 sales@bindicator.com
 www.bindicator.com

venture
 MEASUREMENT

2015 All rights reserved.
 All data subject to change without notice.

LMR180001 Rev F