



# Flo-Guard™ Broken Bag Detector Installation & Operation Manual



Order from: **C A Briggs Company**

622 Mary Street; Suite 101; Warminster, PA 18974

Phone: 267-673-8117 - Fax: 267-673-8118

[Sales@cabriggs.com](mailto:Sales@cabriggs.com) - [www.cabriggs.com](http://www.cabriggs.com)





# Flo-Guard™ Broken Bag Detector Installation & Operation Manual

## CONTENTS

<b>I. HANDLING &amp; STORAGE .....</b>	<b>1</b>
Inspection and Handling	
Disposal and Recycling	
Storage	
<b>II. GENERAL SAFETY .....</b>	<b>2</b>
Authorized Personnel	
Use	
Misuse	
<b>III. PRODUCT DESCRIPTION .....</b>	<b>3</b>
Function	
Figure 1: Process Options	
Applications	
Features	
Technical Specifications	
Approvals	
<b>IV. MECHANICAL INSTALLATION.....</b>	<b>5</b>
Mounting Consideration	
General Installation	
<b>V. ELECTRICAL INSTALLATION .....</b>	<b>6</b>
General Safety	
Wiring	
Figure 2: Board Layout	
Figure 3: Standard Wiring	
Figure 4: Remote Wiring	
Figure 5: Remote Cable Assembly	
<b>VI. SET-UP .....</b>	<b>10</b>
Fail-Safe Selection	
Figure 6: Fail-Safe Operation	
Sensitivity Settings	
Time Delay	
Time Delay Selections	
<b>VII. MAINTENANCE .....</b>	<b>11</b>
<b>VIII. TROUBLESHOOTING .....</b>	<b>11</b>
<b>IX. DIMENSIONAL DRAWINGS.....</b>	<b>12</b>

## SAFETY SYMBOLS



### **WARNING:**

IDENTIFIES CONDITIONS OR PROCEDURES, WHICH IF NOT FOLLOWED, COULD RESULT IN SERIOUS INJURY. RISK OF ELECTRICAL SHOCK.



### **CAUTION:**

IDENTIFIES CONDITIONS OR PROCEDURES, WHICH IF NOT FOLLOWED, COULD RESULT IN SERIOUS DAMAGE OR FAILURE OF THE EQUIPMENT.

# Flo-Guard™ Broken Bag Detector

## I. HANDLING AND STORAGE

### SAVE THESE INSTRUCTIONS

#### INSPECTION AND HANDLING

Do not dispose of the carton or packing materials.

Each package should be inspected upon receipt for damage that may have occurred due to mishandling during shipping. If the unit is received damaged, notify the carrier or the factory for instructions. Failure to do so may void your warranty. If you have any problems or questions, consult Customer Support at 1-800-778-9242.

#### DISPOSAL AND RECYCLING

This product can be recycled by specialized companies and must not be disposed of in a municipal collection site. If you do not have the means to dispose of properly, please contact for return and disposal instructions or options.

#### STORAGE

If the device is not scheduled for immediate installation following delivery, the following steps should be observed:

1. Following inspection, repackage the unit into its original packaging.
2. Select a clean dry site, free of vibration, shock and impact hazards.
3. If storage will be extended longer than 30 days, the unit must be stored at temperatures between -40° and 158° F (-40° to 70° C) in non-condensing atmosphere with humidity less than 85%.



**CAUTION: DO NOT STORE A NON-POWERED UNIT OUTDOORS FOR A PROLONGED PERIOD.**

## II. GENERAL SAFETY

### **AUTHORIZED PERSONNEL**

All instructions described in the document must be performed by authorized and qualified service personnel only. Before installing the unit, please read these instructions and familiarize yourself with the requirements and functions of the device. The required personal protective equipment must always be worn when servicing this device.

### **USE**

The device is solely intended for use as described in this manual. Reliable operation is ensured only if the instrument is used according to the specifications described in this document. For safety and warranty reasons, use of accessory equipment not recommended by the manufacturer or modification of this device is explicitly forbidden. All servicing of this equipment must be performed by qualified service personnel only. This device should be mounted in locations where it will not be subject to tampering by unauthorized personnel.

### **MISUSE**

Improper use or installation of this device may cause the following:

- Personal injury or harm
- Application specific hazards such as vessel overfill
- Damage to the device or system

If any questions or problems arise during installation of this equipment, please contact the Customer Support at 800-778-9242.

### III. PRODUCT DESCRIPTION

#### FUNCTION

The Flo-Guard™ is a supersensitive flow detection switch which can be used to detect dust particles in bag houses or flow loss of dry, solid, powder or granulated materials, such as coal, plastic or salt. The unique combination of detecting the motion of flowing dust or sensing the loss of flow is provided through the micro-controller designed into the circuitry. The micro-controller is also used to provide many other features which make this instrument the most reliable sensor of its type on the market.

Figure 1. Process Options

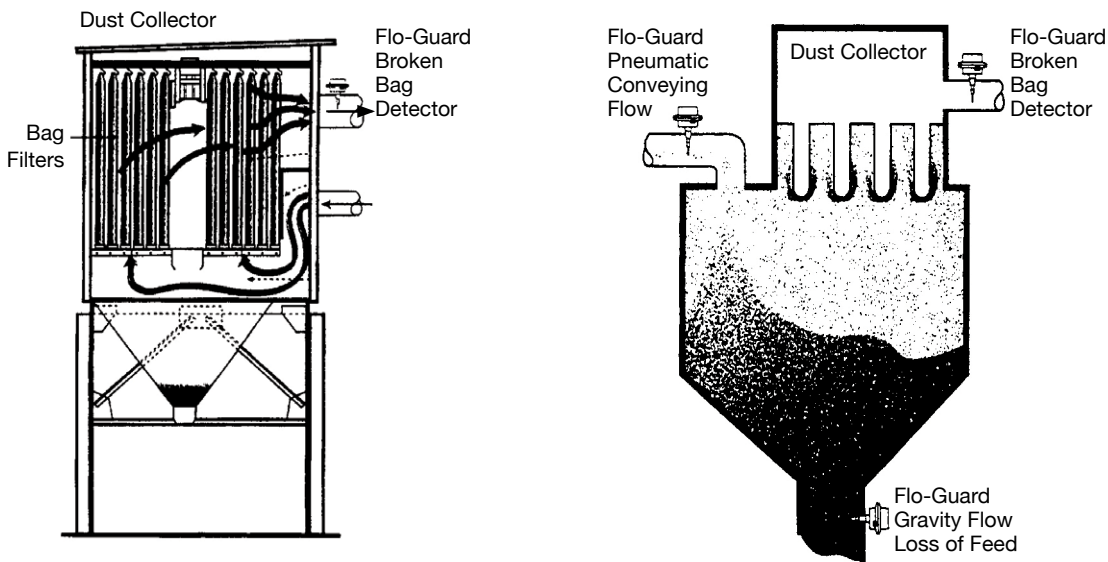

#### APPLICATIONS

The Flo-Guard can be used to detect the flow of dust or granules in nearly any material handling system. It will sense dust resulting from a broken bag in a dust collector and it will also sense solid particles in other material handling equipment, for example, a flow through a chute. This device does not sense the presence or absence of material, rather the flow of material as it moves past the probe.

#### FEATURES

- Lights
- Triboelectric Technology
- Alarm Verification
- Senses Dust particles of Solids Flow
- Patented Temperature Compensation
- External Fob Function Test
- Sensitivity Selection

## TECHNICAL SPECIFICATIONS

FUNCTIONAL	
Output Relay	DPDT, 5A @ 250 VAC or 28 VDC
Input Power	120 or 240 VAC, 60 Hz
Temperature Range	-40° to 180° F (-40° to 80° C)
Probe	325° F (162° C) maximum
Pressure	30 psi (211 kg/cm <sup>2</sup> ) 1 <sup>1</sup> / <sub>4</sub> " NPT aluminum mount 50 psi (3.5 kg/cm <sup>2</sup> ) 3 <sup>4</sup> / <sub>4</sub> " NPT SS mount
Time Delay	0, 5, 10 or 15 seconds field selectable for ON or OFF
Failsafe	Field adjustable to alarm at presence or absence of material flow
PHYSICAL	
Senses Dust at bottom	0.00028 grams/ft <sup>3</sup>
Enclosure Ratings	General purpose NEMA 4X Explosion-proof NEMA 7/9
Enclosure Material	Polyester coated aluminum
Mounting	1 <sup>1</sup> / <sub>4</sub> " NPT aluminum or 3 <sup>4</sup> / <sub>4</sub> " NPT SS
Air Purge	1 <sup>1</sup> / <sub>4</sub> " NPT SS
Probe Material	316 SS
Insulation Material	Teflon <sup>®</sup>
Air Purged	Maximum 1 psi recommended

## APPROVALS

Hazardous Location: UL (US and Canada) Class 1, Groups C & D, Class II, Groups E, F, G



## IV. MECHANICAL INSTALLATION

### MOUNTING CONSIDERATIONS

- The Flo-Guard is mounted on a  $\frac{3}{4}$ " or  $1\frac{1}{4}$ " NPT half coupling welded to the side of a pipe, duct or chute.
- Preferred installation location is in a straight portion of a vertical pipe, at least 12 in. (30 cm) from any elbows, reduction fittings or other obstructions.
- When installed in a straight portion of a horizontal pipe the probe tip must have sufficient clearance from the wall, to eliminate the possibility of product build-up
- Insulator portion of probe should just barely penetrate into the flow stream

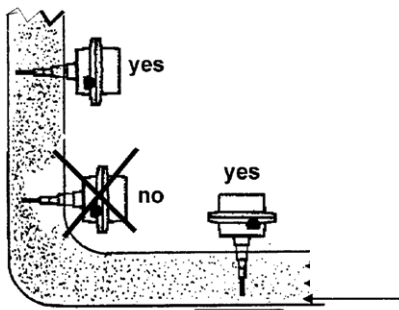

1. Minimum pipe diameter must be 6 inches.
2. Allow 2 pipe diameters from any obstruction to the position of the Flo-Guard.

**NOTE:** If installing unit in a non-metallic pipe, duct or chute, please consult with the factory before installation.

### GENERAL INSTALLATION

1. Determine location of unit.
  - a. Type A assembly is designed to mount on either a  $1\frac{1}{4}$ " aluminum, pressure rating 30 psi (2.1 kg/cm<sup>2</sup>); or  $\frac{3}{4}$ " stainless steel NPT coupling, pressure rating 50 psi (3.5 kg/cm<sup>2</sup>)
2. Insert unit into mounting location.
3. Tighten unit into place using the coupling; do NOT tighten by rotating the housing.
4. Proceed to Electrical Installation.

## V. ELECTRICAL INSTALLATION



**WARNING: REMOVE POWER FROM THE UNIT BEFORE INSTALLING, REMOVING, OR MAKING ADJUSTMENTS**

### GENERAL SAFETY

When using electrical equipment, you should always follow basic safety precautions, including the following:

- The installation/wiring of this product must comply with all national, federal, state, municipal, and local codes that apply.
- Properly ground the enclosure to an adequate earth ground.
- Do not modify any factory wiring. Connections should only be made to the terminals described in this section.
- All connections to the unit must use conductors with an insulation rating of 300 V minimum, rated for 105 C, a minimum flammability rating of VW-1, and be of appropriate gauge for the voltage and current required (see specs).
- Do not allow moisture to enter the electronics enclosure. Conduit should slope downward from the housing. Install drip loops and seal conduit with silicone rubber product.

### DISCONNECT REQUIREMENTS FOR PERMANENTLY INSTALLED EQUIPMENT

A dedicated disconnecting device (circuit breaker) must be provided for the proper installation of the unit. If independent circuits are used for power input and main relay outputs, individual disconnects are required.

Disconnects must meet the following requirements:

- Located in close proximity to the device
- Easily accessible to the operator
- Appropriately marked as the disconnect for the device and associated circuit
- Sized appropriately to the requirements of the protected circuit (See Specifications)

### WIRING

1. Attach power leads to terminal block (L1, L2) shown in Figure 2.
2. Attach ground lead to green grounding screw inside the enclosure; see Figure 2
3. Ground unit chassis to earth using green grounding screw outside the enclosure. See Figure 5.



**WARNING: UNIT MUST BE GROUNDED FOR PROPER OPERATION**

Figure 2. Board Layout

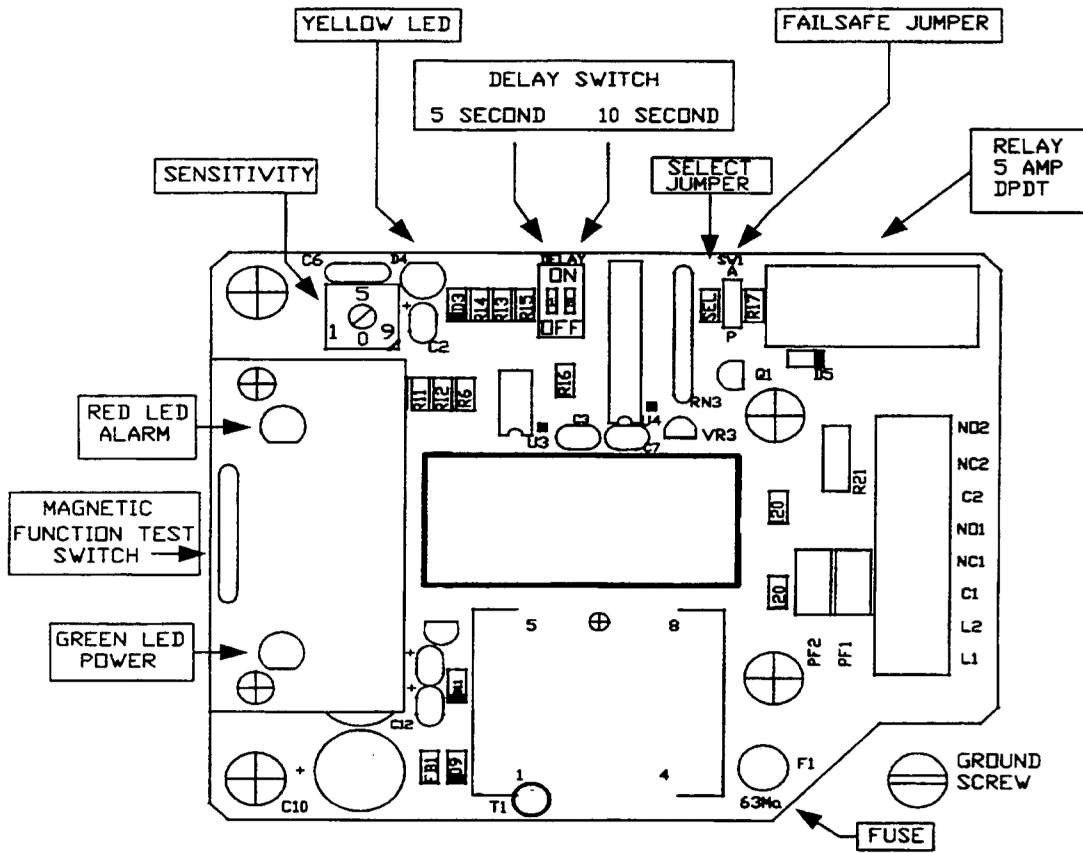

Figure 3. Standard Wiring

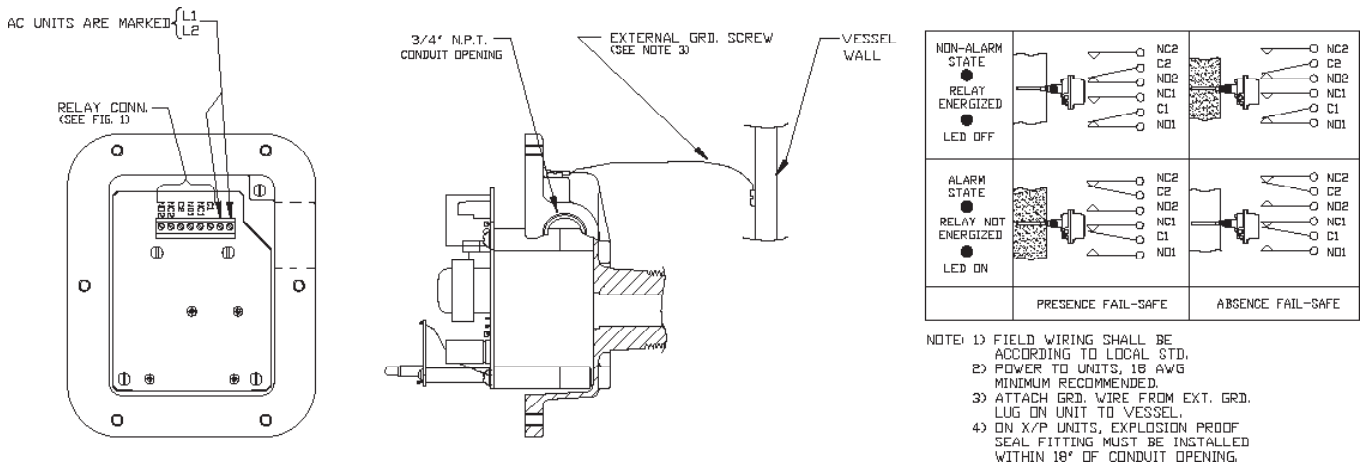

Figure 4. Remote Wiring

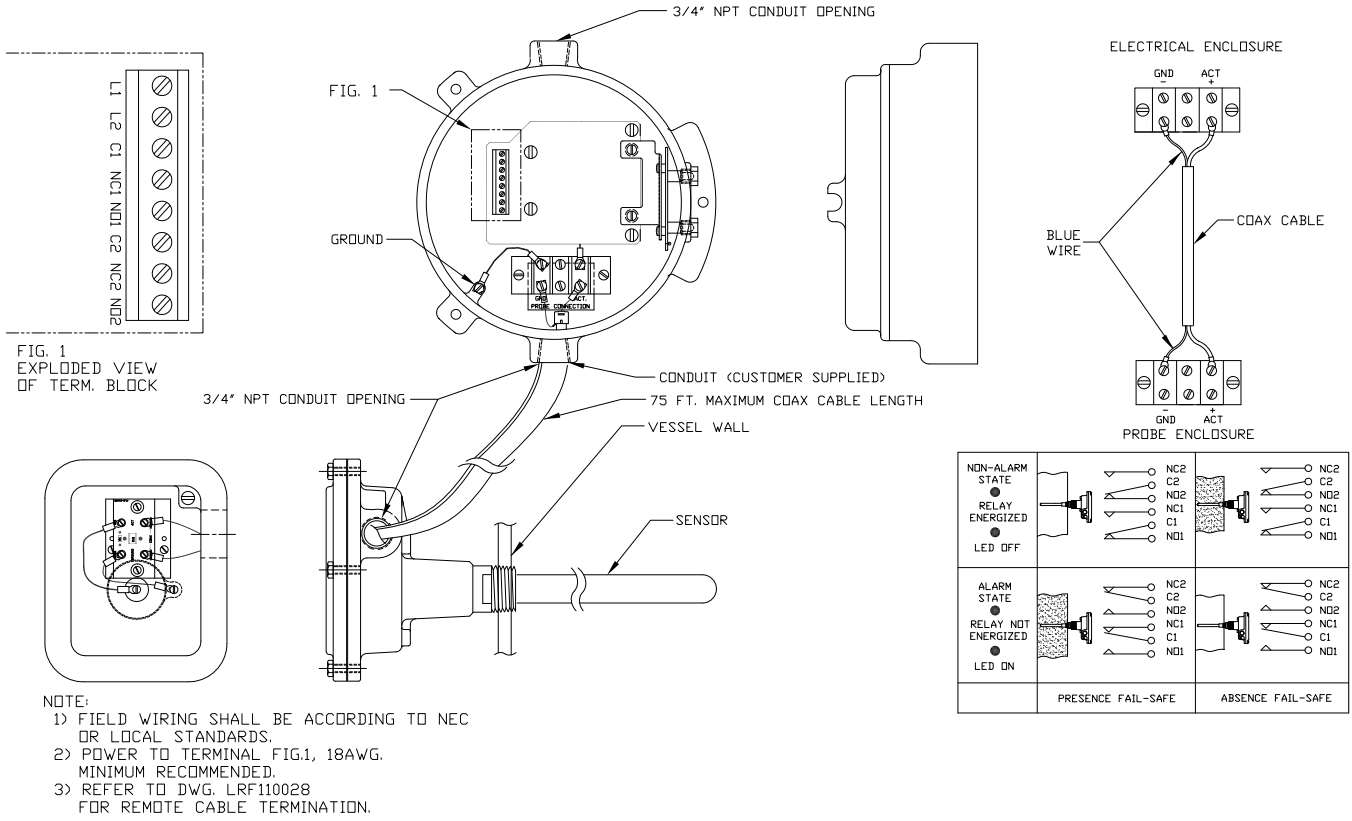
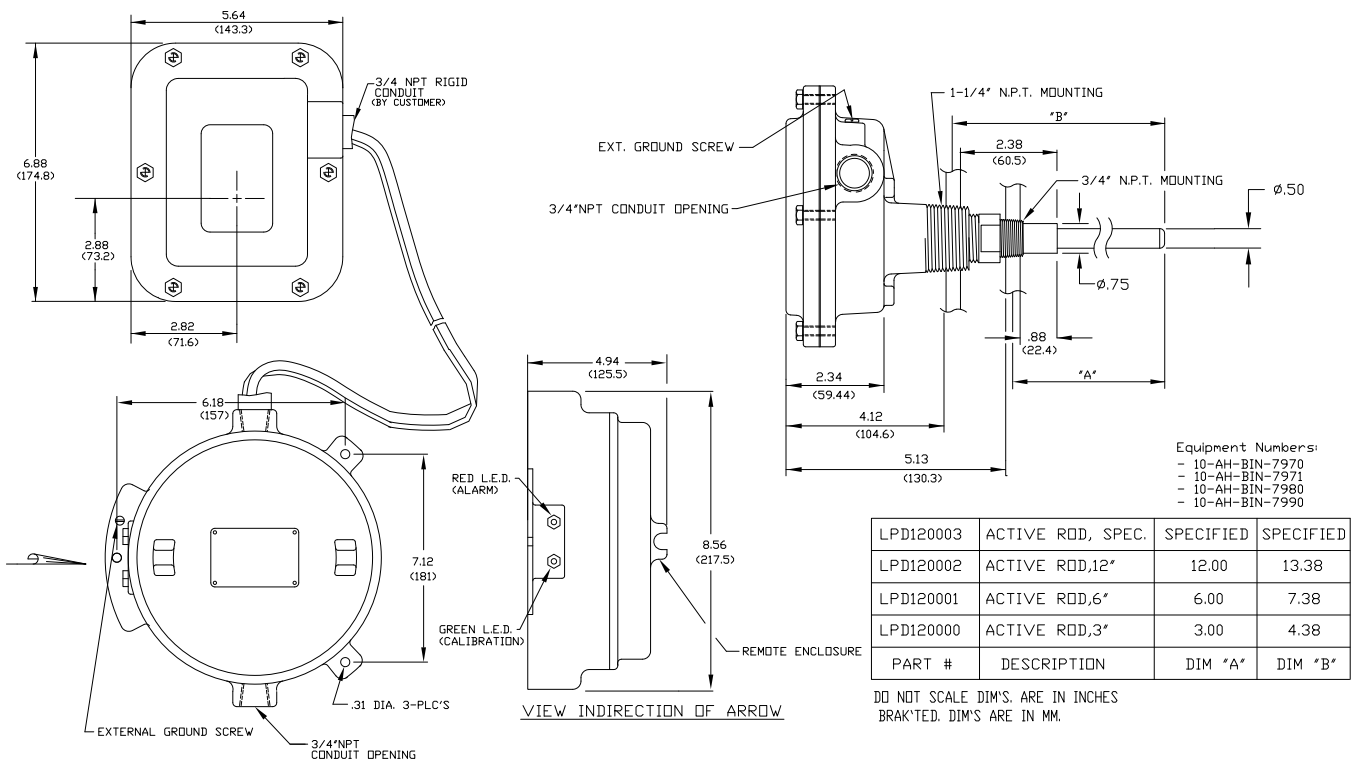

Figure 5. Remote Cable Assembly



## VI. SET-UP

### FAIL-SAFE SELECTION

The Flo-Guard is shipped from the manufacturer in the “P” Fail-Safe condition, meaning the alarm occurs at the presence of flow of material.

Presence Operation (Fail-Safe Jumper Position P) – When material flow is present, the output relay de-energizes indicating an alarm condition. Use this setting in broken filter bag applications.

Absence Operation (Fail-Safe Jumper Position A) – When material flow is absent, the output relay de-energizes indicating an alarm condition. Use this setting in flow sensing applications, where flow is normal and an alarm is needed if the flow of material stops.

Figure 6. Fail-Safe Operation

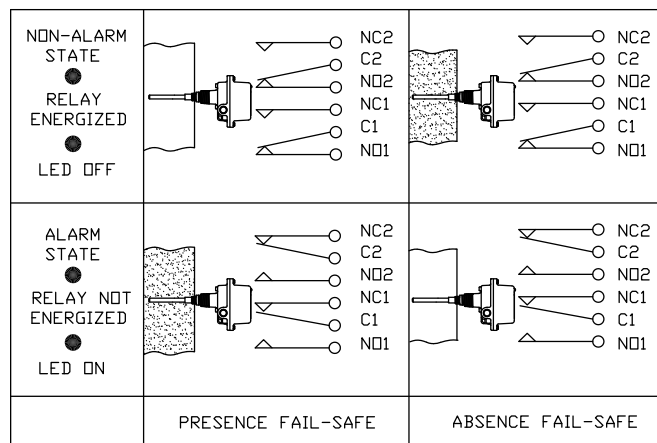

### SENSITIVITY SETTINGS

Sensitivity is adjusted with the unit installed in a clean air system. From position “0” rotate sensitivity switch clockwise until yellow LED is off. If yellow LED flickers, increase switch position to next higher value until yellow LED remains off.

Position 0 = Most Sensitive

Position 9 = Least Sensitive

### TIME DELAY

SWITCH 1	SWITCH 2	TIME DELAY
OFF	OFF	1 second
ON	OFF	5 seconds
OFF	ON	10 seconds
ON	ON	15 seconds

## TIME DELAY SELECTIONS

The 'SELECT' jumper determines when the TIME-DELAY is activated. The jumper is normally in place when shipped from the factory and can be removed to alter the delay sequence.

**SELECT Jumper Intact:** The unit is configured as a Dust-Sensor; the delay is activated when particle (dust) flow is detected, and an alarm will occur after the predetermined delay. The alarm will reset instantly once the airstream has cleared.

**SELECT Jumper Removed:** The unit is configured as a Flow-Sensor; the delay is activated upon loss of particle flow, and the alarm will occur after the predetermined delay. The alarm will reset instantly once particle flow returns.

## VII. MAINTENANCE

It is not recommended that any preventative maintenance be performed on this unit.

## VIII. TROUBLESHOOTING

Please consult with the factory for any technical issues.

# XI. DIMENSIONAL DRAWINGS

## Standard Unit

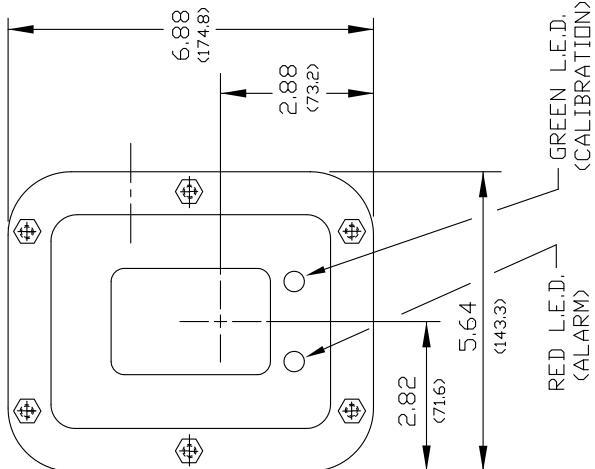
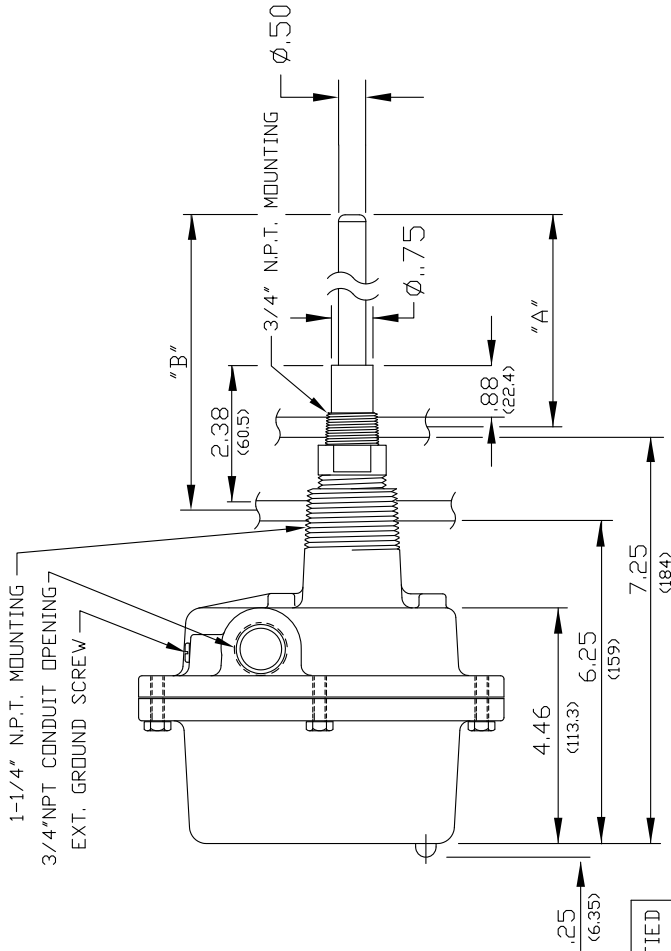

PART #	DESCRIPTION	DIM "A"	DIM "B"
LPD120003	ACTIVE ROD, SPEC.	SPECIFIED	SPECIFIED
LPD120002	ACTIVE ROD,12"	12.00	13.38
LPD120001	ACTIVE ROD,6"	6.00	7.38
LPD120000	ACTIVE ROD,3"	3.00	4.38

Remote Unit

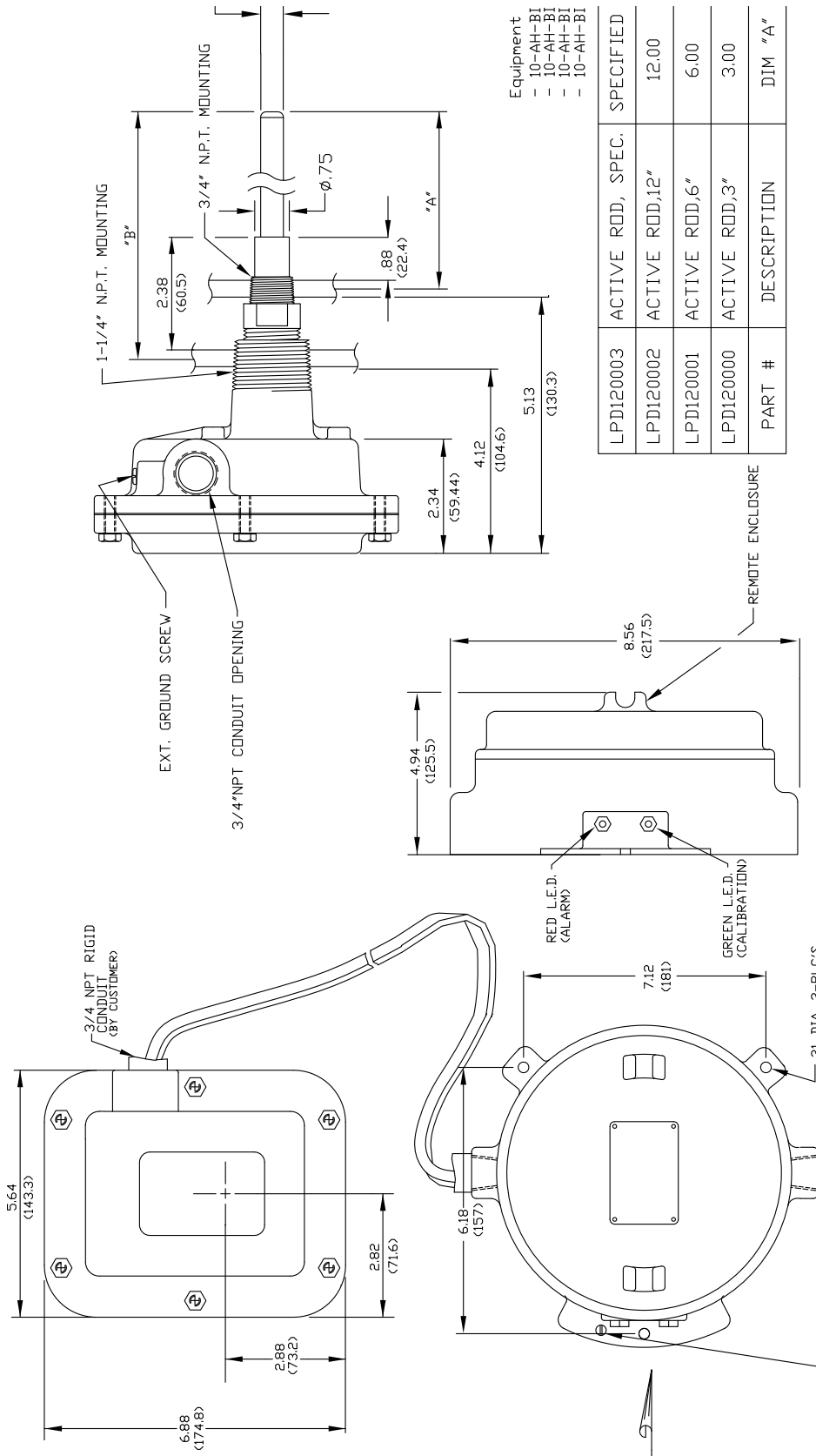

PART #	DESCRIPTION	DIM "A"
LPD120003	ACTIVE ROD, SPEC.	
LPD120002	ACTIVE ROD, 12"	12.00
LPD120001	ACTIVE ROD, 6"	6.00
LPD120000	ACTIVE ROD, 3"	3.00



Standard Unit with Air Purge

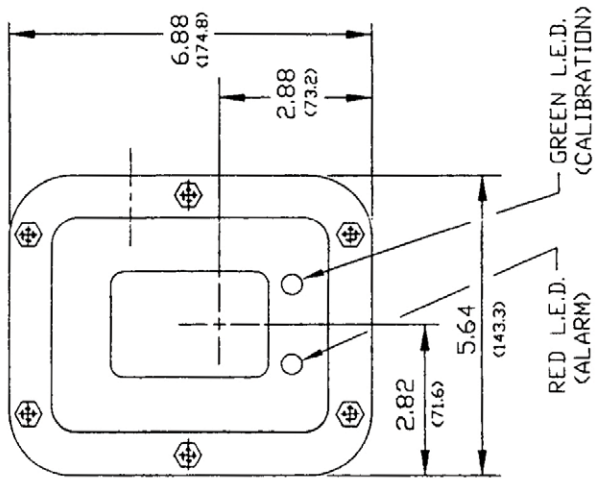
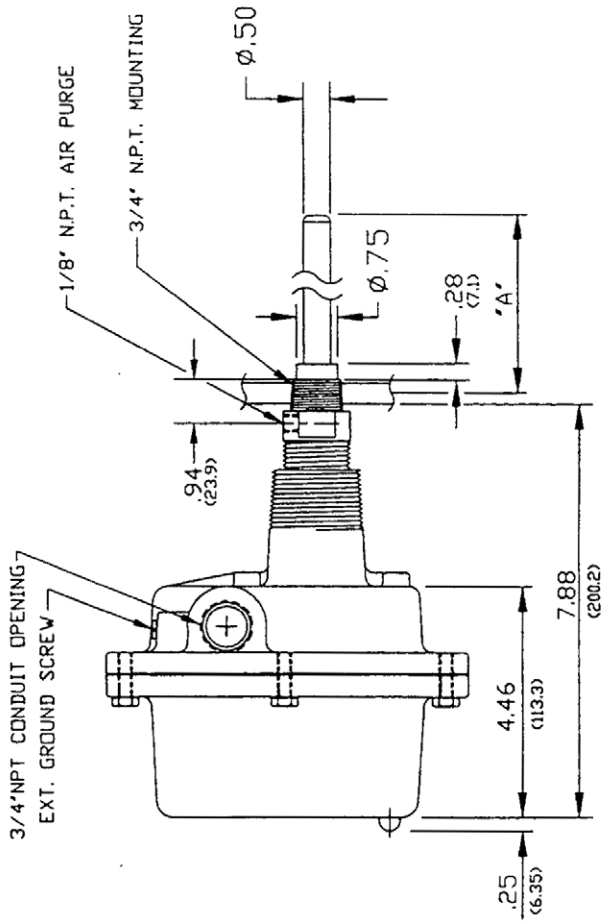

PART #	DESCRIPTION	SPECIFIED	SPECIFIED
LPD120003	ACTIVE ROD, 12'	11.37	
LPD120002	ACTIVE ROD, 6'	5.37	
LPD120000	ACTIVE ROD, 3'	2.37	
			DIM 'A'

Remote Unit with Air Purge

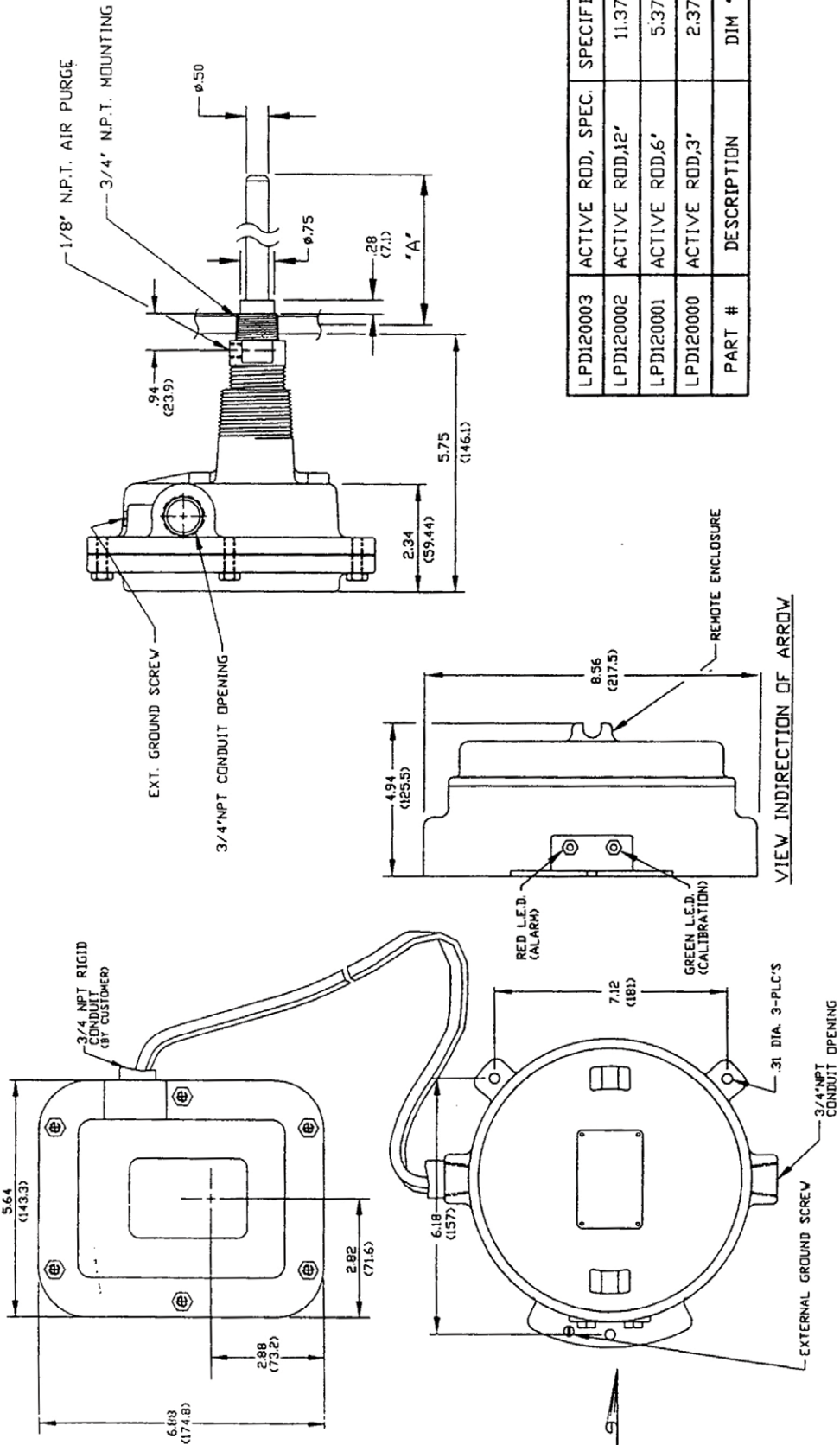

PART #	DESCRIPTION	SPECIFIED	DIM 'A'
LPD120003	ACTIVE ROD, 12'	11.37	
LPD120002	ACTIVE ROD, 6'	5.37	
LPD120001	ACTIVE ROD, 3'	2.37	

DO NOT SCALE. DIM'S. ARE IN INCHES  
BRACKETED DIM'S ARE IN MM.

**Notes:**



150 Venture Boulevard  
Spartanburg, SC 29306  
Tel: (800) 778-9242  
Fax: (864) 574-8063  
sales@bindicator.com  
www.bindicator.com

**venture**  
MEASUREMENT

2013 All rights reserved.  
All data subject to change without notice.

LPD180001 Rev. C