



Order from: **C A Briggs Company**

622 Mary Street; Suite 101; Warminster, PA 18974

Phone: 267-673-8117 - Fax: 267-673-8118

Sales@cabriggs.com - www.cabriggs.com

PRODUCT CATALOGUE

Level Sensors, Switches and Controls

CABriggs.com



Table of Contents

Remote Tank Level Monitoring	4
Non-Contact Radar Level Sensors	6
Liquid Radar Level Sensor R-LIQ	8
Solid Material Radar Level Sensor R-SLD	9
Explosion Proof Radar Level Sensor R-EXP	10
Interface Detection Radar Level Sensor R-ID	11
Sanitary / Hygienic Radar Level Sensor R-SAN	12
High Temperature Radar Level Sensor R-HT	13
Very High Temperature Radar Level Sensor R-VHT	14
High Pressure Radar Level Sensor R-HPR	15
Remote Radar Level Sensor (continuous power) R-RM	16
Wireless Remote Radar Level Sensor (battery or solar panel) R-RMB	17
Flood Monitoring Radar Level Sensor R-FM	18
Fast Response Marine Radar Level Sensor R-FR	19
Anti-Collision Radar Level Sensors R-AC	20
Non-Contact Ultrasonic Level Sensors	21
Liquid Ultrasonic Level Sensor UL-LIQ	24
Solid Material Ultrasonic Level Sensor UL-SLD	25
Sanitary / Hygienic Ultrasonic Level Sensor UL-SAN	26
High Temperature Ultrasonic Level Sensor UL-HT	27
Remote Ultrasonic Level Sensor (continuous power) UL-RM	28
Wireless Remote Ultrasonic Level Sensor (battery or solar panel) UL-RMB	29
Fast Response Ultrasonic Level Sensor (2-wire loop-powered) UL-FR	30
Ultrasonic Transmitter with Detached Transducer UL-RT	31
Non-Contact Mini Ultrasonic Level Transmitters	32
Liquid Mini Ultrasonic Level Transmitter UM-LIQ	32
Sanitary / Hygienic Mini Ultrasonic Level Transmitter UM-SAN	33
High Temperature Mini Ultrasonic Level Transmitter UM-HT	34
Short Blanking Mini Ultrasonic Level Transmitter UM-SB	35
Submersible Ultrasonic Level Sensor	36
Liquid Submersible Ultrasonic Level Sensor UMM-LIQ	36
Non-Invasive Ultrasonic Level Switch	37
Liquid Non-Invasive Level Switch US-LIQ	37
High Temperature Non-Invasive Level Switch US-HT	38
High Pressure Non-Invasive Level Switch US-HPR	39
Controllers and Displays	40
Cellular Gateway	41
Remote Dry Contact Monitor	42
Relay Controller	43
Wall Mount Readout Display	44
Sensor Mount Readout Display	45
Mounting Accessories	46
Approvals	47

Level Sensors, Switches and Controls



Remote Tank Level Monitoring

Complete platform with cellular enabled level sensors and controllers, a cloud-based customer portal and 24/7 ABM remote support.



Non-Contact Radar Sensors

Ideal for continuous level measurement for liquid, slurry or solid material applications in challenging environments.



Non-Contact Ultrasonic Sensors

Ideal for continuous level measurement for liquid, slurry or solid material applications without vapours / gases or heavy dust.



Non-Contact Mini Ultrasonic Transmitters

Ideal for continuous level measurement in short range liquid applications measuring weirs, small tanks, drums, totes or barrels.



Submersible Ultrasonic Sensor

Ideal for continuous level measurement in liquid applications for underwater pump control / protection and liquid-solid interface detection.



Non-Invasive Ultrasonic Switches

Ideal for point level measurement in liquid tanks that benefit from non-invasive operation such as high pressure or high viscous materials.



Controllers and Displays

Various options to meet your need with Cellular Gateways, Dry Contact Monitors, Relay Controller, and Loop-Powered Displays.



Mounting Accessories

ABM provides various mounting and aiming accessories to make installation simple and optimize the performance of your sensor.



Remote Tank Level Monitoring

Gain real-time visibility into your process 24/7. Remote tank level monitoring lets you check the level in multiple tanks, bins, silos or reservoirs, across multiple sites, all from your computer or smart phone. Monitor inventory, optimize operations, improve your efficiency, and maximize profitability.



Cellular Level Sensors

ABM's non-contact level sensors with built-in cellular modems are plug-and-play, automatically connecting to the ABM secured servers for ease of installation. Battery, solar panel or continuous power options are available.



Cellular Devices

The Cellular Gateway connects up to eight new or existing ABM level sensors for remote monitoring and total sensor control. The Remote Dry Contact Monitor (RDCM) is designed to monitor a single dry relay or switch contact.



Sensor Access Website

Users can remotely monitor their assets from one location for real-time data visibility. The cloud-based Sensor Access website features full sensor configuration, tank collection dashboards, and 5 alarms and email notification alerts.



Remote Active Control

Gain peace of mind with ABM sitting remotely next to your level sensor. Unlike any other remote monitoring solution, ABM's platform has full online support for setup, sensor control and optimization, and process insights.

ABM Technology Advantage

ABM's self-adjusting sensors continually monitor conditions in the environment and automatically adjust the transmitted energy and receiver sensitivity to match to the current tank conditions. This technique allows the receiver to detect only one echo from the measured media while all false echoes are pushed under the noise level and eliminated. The self-adjusting technique also gives the same amplitude of wanted echoes regardless of distance to the target. With one echo only, signal processing is very simple and the certainty of the measured echo being the target is 100%. This makes the ABM sensors very accurate and reliable.

- Plug-and-play operation, no mapping or downloading several parameters
- No influence from mounting, walls or small obstructions on sensors performance
- Non-contact and self-cleaning nature provides maintenance free operation

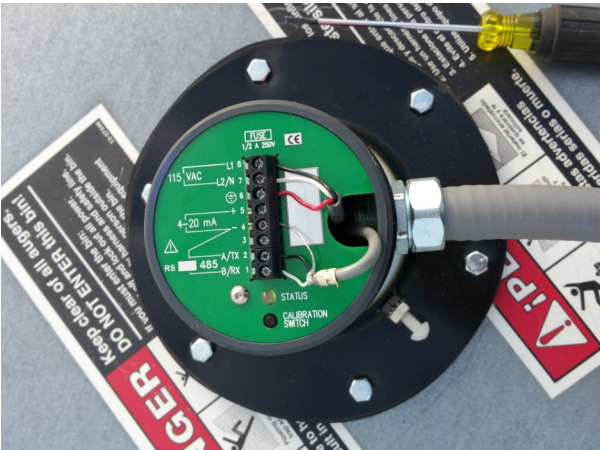

Radar Features:

- High resolution with short transmitted pulses ensures accuracy and enables liquid interface detection
- Very narrow radiation beam enables installation close to tank walls
- Fast response (up to 20 updates per second) for fast moving applications such as vehicles or boats
- High dynamics enables detection of very low dielectric constant liquids (>2)
- Teflon rod antenna resists material and moisture build-up
- No influence from temperature, pressure or humidity on measurement

Ultrasonic Features:

- Very uniform polar pattern, negligible side lobes
- Very uniform near field
- Wide frequency bandwidth that produces uniform echoes, short ringing and wide temperature operation
- Automatic temperature compensation
- Fast response (up to 20 echoes per second) for fast moving applications such as conveyor belts
- Highly active driver automatically removes condensation and solid material build-up from transducer face

Radar Applications



Liquid Level Monitoring

Radar is ideal for monitoring liquids with vapors, gases or volatile surfaces. Choose a radar sensor with the range for your application.



Solid Material Level Monitoring

For dusty solids and powder applications, the dual frequency and higher 26 GHz frequency radar models help to penetrate the dusty environment found in solids-level storage silos and bins.

Explosion Proof Applications

For measurement in areas classified as hazardous (Class I, Division 1), such as those with gases, petrochemicals, vapors, and dust. These areas require containment of the atmosphere.

Interface Detection Applications

Ideal for monitoring the interface between liquids and solids, such as oil-water. The non-contact radar sensor measures the oil-water interface and the top of the oil. The current output shows both levels.



Sanitary / Hygienic Applications

Ideal for sanitary/hygienic applications, the radar sensor has a food-grade Teflon antenna with sanitary ferrule tri-clamp mounting. The sensor withstands steam cleaning or clean-in-place (CIP), is quickly removable, and easily re-installed.

High Temperature Applications

The radar sensor is ideal for applications with elevated process temperatures and has a Teflon decoupler designed for thermal isolation. Environmental (ambient) temperature does not affect the sensor's performance. A horn antenna with a bottom flange is recommended for very high temperature applications above 177°C (350°F).



High Pressure Applications

A radar sensor with a special high-pressure Teflon antenna is used for monitoring processes with elevated pressure up to 70 bar (1015 PSI).

Remote Monitoring Applications

Remote non-contact radar level sensors have a built-in cellular modem for remote communication and ABM support. Continuous power and battery or solar panel (wireless) power options are available.

Outdoor Flood Monitoring

The dual frequency radar is used to reliably monitor levels of rivers, lakes and oceans without influence from weather conditions. The radar works even in dry seasons when there is no water in riverbeds.



Marine Fast Response Applications

The radar with fast response protocols (10 to 30 updates per second) is ideal for measuring wave profiles to control optimal vessel trimming.

Anti-Collision Systems

An anti-collision system based on two radar sensors operating at different frequencies maintains a safe working distance between two cranes operating on the same track.

Non-Contact Radar Level Sensors

An electromagnetic pulse is transmitted from the sensor. The pulse travels to the surface being monitored and is reflected off the surface back to the sensor. The time-of-flight is divided by two and converted to an output signal directly proportional to the level.

Radar should be your choice when dealing with challenging environments such as vapor, temperature variations, extreme temperatures, extreme dust, wind, foam, ice or acoustic noise.

Family	Application	Maximum Range	Frequency	Process Temperature	Process Pressure	Antenna	Mounting
R-LIQ	Liquids	Up to 340 ft (103.6 m)	6.3 GHz 5.8 GHz	-40 to 80°C (-40 to 176°F)	≤ 5 Bar (72.5 psi)	Teflon Rod or SS316L Horn	1.5", 2" or 3" NPT
R-SLD	Solid Material	Up to 340 ft (103.6 m)	6.3 / 26 GHz 26 GHz 26 / 78 GHz	-40 to 80°C (-40 to 176°F)	≤ 5 Bar (72.5 psi)	SS316L Horn	3" NPT
R-EXP	Explosion Proof (Class I, Division 1)	Up to 240 ft (73.2 m)	6.3 GHz 5.8 GHz	-40 to 80°C (-40 to 176°F)	≤ 5 Bar (72.5 psi)	Teflon Rod or SS316L Horn	1.5", 2" or 3" NPT
R-ID	Interface Detection (Class I, Division 1)	Up to 240 ft (73.2 m)	6.3 GHz 5.8 GHz	-40 to 80°C (-40 to 176°F)	≤ 5 Bar (72.5 psi)	Teflon Rod	1.5" or 2" NPT
S-SAN	Sanitary / Hygienic	Up to 100 ft (30.5 m)	6.3 GHz 5.8 GHz	-40 to 204°C (-40 to 400°F)	≤ 2 Bar (29 psi)	Food Grade Teflon Rod	2" Tri-Clamp
R-HT	High Temperature	Up to 100 ft (30.5 m)	6.3 GHz 5.8 GHz	-40 to 177°C (-40 to 350°F)	≤ 2 Bar (29 psi)	Teflon Rod with Decoupler	2" or 3" NPT
R-VHT	Very High Temperature	Up to 100 ft (30.5 m)	6.3 GHz 5.8 GHz	-40 to 300°C (-40 to 572°F)	≤ 2 Bar (29 psi)	SS316L Horn with Bottom Flange	8" Flange
R-HPR	High Pressure	Up to 100 ft (30.5 m)	6.3 GHz 5.8 GHz	-40 to 80°C (-40 to 176°F)	≤ 70 Bar (1015 psi)	High Pressure Teflon Rod	1.5", 2" or 3" NPT
R-RM	Remote Monitoring (continuous power)	Up to 340 ft (103.6 m)	6.3 GHz 5.8 GHz 6.3 / 26 GHz	-40 to 80°C (-40 to 176°F)	≤ 5 Bar (72.5 psi)	Teflon Rod or SS316L Horn	1.5", 2" or 3" NPT
R-RMB	Remote Monitoring (battery or solar panel)	Up to 340 ft (103.6 m)	6.3 GHz 5.8 GHz 6.3 / 26 GHz	-40 to 80°C (-40 to 176°F)	≤ 5 Bar (72.5 psi)	Teflon Rod or SS316L Horn	1.5", 2" or 3" NPT
R-FM	Flood Monitoring	Up to 340 ft (103.6 m)	6.3 / 26 GHz	-40 to 80°C (-40 to 176°F)	≤ 5 Bar (72.5 psi)	SS316L Horn	3" NPT
R-FR	Fast Response	Up to 340 ft (103.6 m)	6.3 GHz 5.8 GHz	-40 to 80°C (-40 to 176°F)	≤ 5 Bar (72.5 psi)	Teflon Rod or SS316L Horn	1.5", 2" or 3" NPT
R-AC	Anti-Collision	Up to 240 ft (73.2 m)	6.3 GHz and 26 GHz	-40 to 80°C (-40 to 176°F)	≤ 5 Bar (72.5 psi)	Teflon Rod or SS316L Horn	3" NPT

Non-Contact Radar Level Sensors for Liquid Applications | R-LIQ



The R-LIQ pulse radar level sensor is the ideal solution for liquid level applications in challenging environments with vapours, gases, foaming, ice or volatile surfaces.

Features

- Maintenance-free, non-contact continuous level measurements
- Build-up resistant Teflon rod antenna (sheds condensation) or SS316L horn antenna options
- Plug-and-play installation with simple calibration
- 2-wire loop-powered, 3-wire or 4-wire operation
- 4-20 mA / 20-4 mA output standard
- Optional HART, RS232 or RS485 communications with free calibration, diagnostics and data logging software
- PLC compatible (Modbus RTU)
- Aluminum and SS316L housing options to withstand any environment
- Ingress protection IP68 rating (NEMA 6)



Applications

Liquid level measurement for: Water, Wastewater, Chemical, Food, Beverage and more.

Technical Data	
Measuring Range:	Up to 340 ft (103.6 m)
Temperature:	-40 to 80°C (-40 to 176°F)
Pressure Rating:	≤ 5 Bar (72.5 psi)
Mounting:	1.5" - 3" NPT

Catalogue Number Ordering		
Supply Voltage:	16-30 VDC Loop-Powered (2-wire)	200
	12-30 VDC Power (3-wire)	300
	115 VAC Power (4-wire)	400
	230 VAC Power (4-wire)	430
Maximum Range:	17 ft (5.2 m)	017
	33 ft (10.1 m)	033
	50 ft (15.2 m)	050
	100 ft (30.5 m)	100
	140 ft (42.7 m)	140
	240 ft (73.2 m)	240
Frequency:	170 ft (51.8 m)	170
	340 ft (103.6 m)	340
	5.8 GHz	R5
	6.3 GHz	R6
Communication:	HART	CH
	RS232	C2
	RS485	C4
Enclosure:	Aluminum	AL
	SS316L	SS
Antenna:	Teflon Rod 10" (extendable)	ATE
	Teflon Rod 12"	ATL
	SS316L Horn 6"	HR6

Dimensions

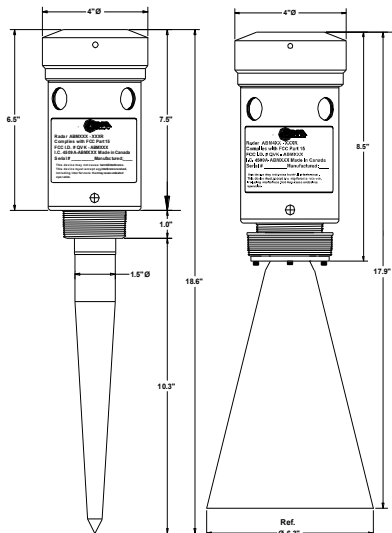

Model:	ABM	- - -	-	- - -	- -	- -	-	- - -	- - -
---------------	-----	-------	---	-------	-----	-----	---	-------	-------

Non-Contact Radar Level Sensors for Solid Material Applications | R-SLD



The R-SLD pulse radar level sensor is the ideal solution for solid material level applications in challenging environments with temperature variations, heavy dust, or acoustic noise.

Features

- No influence from heavy dust, tracks during filling conditions
- Maintenance-free, non-contact continuous level measurements
- Build-up resistant Teflon rod antenna or SS316L horn antenna options
- Swivel aimer mounting recommended for optimal performance
- Plug-and-play installation with simple calibration
- 2-wire loop-powered, 3-wire or 4-wire operation
- 4-20 mA / 20-4 mA output standard
- Optional HART, RS232 or RS485 communications with free calibration, diagnostics and data logging software
- PLC compatible (Modbus RTU)
- Aluminum and SS316L housing options to withstand any environment
- Ingress protection IP68 rating (NEMA 6)



Applications

Solid level measurement for: Cement, Aggregates, Plastics, Animal Feed and more.

Technical Data	
Measuring Range:	Up to 340 ft (103.6 m)
Temperature:	-40 to 80°C (-40 to 176°F)
Pressure Rating:	≤ 5 Bar (72.5 psi)
Mounting:	3" NPT

Catalogue Number Ordering		
Supply Voltage:	16-30 VDC Loop-Powered (2-wire) 12-30 VDC Power (3-wire) 115 VAC Power (4-wire) 230 VAC Power (4-wire)	200 300 400 430
Maximum Range:	17 ft (5.2 m) 33 ft (10.1 m) 50 ft (15.2 m) 100 ft (30.5 m) 140 ft (42.7 m) 240 ft (73.2 m) 340 ft (103.6 m)	017 033 050 100 140 240 340
Frequency:	6.3 / 26 GHz 26 / 78 GHz 26 GHz	R6R2 R2R7 R2
Communication:	HART RS232 RS485	CH C2 C4
Enclosure:	Aluminum SS316L	AL SS
Antenna:	SS316L Horn 6" SS316L Horn 5"	HR6 HR5

Dimensions

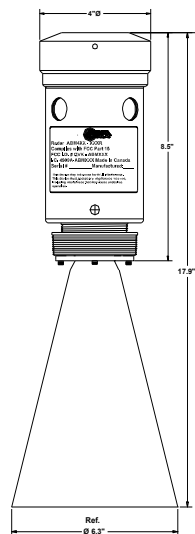

Model:	ABM	-	-	-	-	-	-	-	-	-	SOLIDS
---------------	-----	---	---	---	---	---	---	---	---	---	--------

Non-Contact Radar Level Sensors for Explosion Proof Applications | R-EXP



The R-EXP pulse radar level sensor is the ideal solution for liquid, slurry or solid materials with heavy dust, vapours, gases, foaming, ice or volatile surfaces in areas classified as hazardous.

Features

- Explosion proof - Class I, Division 1 (CID1) approvals
- Maintenance-free, non-contact continuous level measurements
- Build-up resistant Teflon rod antenna or SS316L horn antenna options
- Plug-and-play installation with simple calibration
- 2-wire loop-powered or 3-wire operation
- 4-20 mA / 20-4 mA output standard
- Optional HART, RS232 or RS485 communications with free calibration, diagnostics and data logging software
- PLC compatible (Modbus RTU)
- Aluminum and SS316L housing options to withstand any environment
- Ingress protection IP68 rating (NEMA 6)



Applications

Level measurement for: Petrochemical, Wastewater, Chemical, Beverage and more.

Technical Data	
Measuring Range:	Up to 240 ft (73.2 m)
Temperature:	-40 to 80°C (-40 to 176°F)
Pressure Rating:	≤ 5 Bar (72.5 psi)
Mounting:	1.5" - 3" NPT with rod antenna 3" NPT with horn antenna

Catalogue Number Ordering		
Supply Voltage:	16-30 VDC Loop-Powered (2-wire) 12-30 VDC Power (3-wire)	200 300
Maximum Range:	17 ft (5.2 m) 33 ft (10.1 m) 50 ft (15.2 m) 100 ft (30.5 m) 140 ft (42.7 m) 240 ft (73.2 m)	017 033 050 100 140 240
Frequency:	5.8 GHz 6.3 GHz	R5 R6
Communication:	HART RS232 RS485	CH C2 C4
Enclosure:	Aluminum SS316L	AL SS
Antenna:	Teflon Rod 10" (extendable) Teflon Rod 12" SS316L Horn 6"	ATE ATL HR6
Approvals:	Explosion Proof (CID1)	EXP

Dimensions

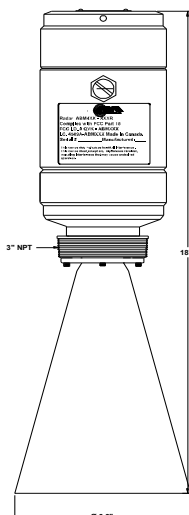

Model:	ABM	- - -	-	- - -	- -	- -	-	- -	- - -	EXP
---------------	-----	-------	---	-------	-----	-----	---	-----	-------	-----

Non-Contact Radar Level Sensors for Interface Detection Applications | R-ID



The R-ID pulse radar level sensor is the ideal solution for oil-water interface detection applications in challenging environments.

Features

- Custom firmware enables detection of oil-water interface and top of oil
- Explosion proof - Class I, Division 1 (CID1) approvals
- Non-contact continuous level measurements
- Maintenance-free operation with build-up resistant Teflon rod antenna
- Plug-and-play installation with simple calibration
- 3-wire operation with 4-20 mA / 20-4 mA output standard
- Optional RS232 or RS485 communications with free calibration, diagnostics and data logging software
- PLC compatible (Modbus RTU)
- Aluminum and SS316L housing options to withstand any environment
- Ingress protection IP68 rating (NEMA 6)



Applications

Oil-Water Interface level measurement for: Oil, Gas, Petrochemical, Refinery, and more.

Technical Data	
Measuring Range:	Up to 240 ft (73.2 m)
Temperature:	-40 to 80°C (-40 to 176°F)
Pressure Rating:	≤ 5 Bar (72.5 psi)
Mounting:	1.5" - 3" NPT

Catalogue Number Ordering		
Supply Voltage:	12-30 VDC Power (3-wire)	300
Maximum Range:	17 ft (5.2 m)	017
	33 ft (10.1 m)	033
	50 ft (15.2 m)	050
	100 ft (30.5 m)	100
	140 ft (42.7 m)	140
Frequency:	5.8 GHz	R5
	6.3 GHz	R6
Communication:	RS232	C2
	RS485	C4
Enclosure:	Aluminum	AL
	SS316L	SS
Antenna:	Teflon Rod 10" (extendable)	ATE
	Teflon Rod 12"	ATL
Approvals:	Explosion Proof (CID1)	EXP

Dimensions

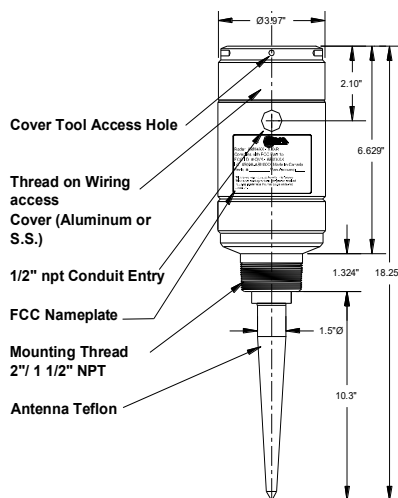

Model:	ABM	300	-	- - -	- -	- -	-	- -	- - - -	EXP
---------------	-----	-----	---	-------	-----	-----	---	-----	---------	-----

Non-Contact Radar Level Sensors for Sanitary / Hygienic Applications | R-SAN



The R-SAN pulse radar level sensor is the ideal solution for hygienic liquid, slurry or solid level applications with vapours, gases, foaming or volatile surfaces.

Features

- Food Grade Teflon antenna with 2" tri-clamp mounting
- Withstands clean-in-place (CIP) processes up to 204°C (400°F)
- Maintenance-free, non-contact continuous level measurements
- Build-up resistant Teflon rod antenna easily sheds condensation
- Plug-and-play installation with simple calibration
- 2-wire loop-powered, 3-wire or 4-wire operation with 4-20 mA / 20-4 mA output standard
- Optional HART, RS232 or RS485 communications with free calibration, diagnostics and data logging software
- PLC compatible (Modbus RTU)
- Aluminum and SS316L housing options to withstand any environment
- Ingress protection IP68 rating (NEMA 6)



Applications

Liquid and solid level measurement for: Water, Food, Beverage and Pharmaceutical.

Technical Data	
Measuring Range:	Up to 100 ft (30.5 m)
Temperature:	-40 to 204°C (-40 to 400°F)
Pressure Rating:	≤ 2 Bar (29 psi)
Mounting:	2" tri-clamp

Catalogue Number Ordering		
Supply Voltage:	16-30 VDC Loop-Powered (2-wire) 12-30 VDC Power (3-wire) 115 VAC Power (4-wire) 230 VAC Power (4-wire)	200 300 400 430
Maximum Range:	17 ft (5.2 m) 33 ft (10.1 m) 50 ft (15.2 m) 100 ft (30.5 m)	017 033 050 100
Frequency:	5.8 GHz 6.3 GHz	R5 R6
Communication:	HART RS232 RS485	CH C2 C4
Enclosure:	Aluminum SS316L	AL SS
Antenna:	Sanitary Teflon Rod	S20
Process Connection:	2" Tri-Clamp	C20

Dimensions

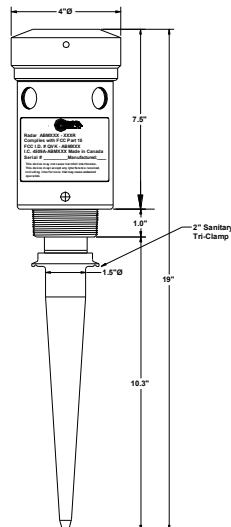

Model:	ABM	-	-	-	-	-	-	-	S20C20
---------------	-----	---	---	---	---	---	---	---	--------

Non-Contact Radar Level Sensors for High Temperature Applications | R-HT



The R-HT pulse radar level sensor is the ideal solution for liquid, slurry or solid level applications with vapours, gases, foaming or volatile surfaces in high temperature processes.

Features

- Teflon decoupler to handle process temperatures up to 177°C (350°F)
- Non-contact continuous level measurements
- Maintenance-free operation with build-up resistant Teflon rod antenna
- Plug-and-play installation with simple calibration
- 2-wire loop-powered, 3-wire or 4-wire operation
- 4-20 mA / 20-4 mA output standard
- Optional HART, RS232 or RS485 communications with free calibration, diagnostics and data logging software
- PLC compatible (Modbus RTU)
- Aluminum and SS316L housing options to withstand any environment
- Ingress protection IP68 rating (NEMA 6)



Applications

Liquid and solid level measurement for: Chemical, Petrochemical, Asphalt, Molten Metal and more.

Technical Data	
Measuring Range:	Up to 100 ft (30.5 m)
Temperature:	-40 to 177°C (-40 to 350°F)
Pressure Rating:	≤ 2 Bar (29 psi)
Mounting:	2" or 3" NPT

Catalogue Number Ordering		
Supply Voltage:	12-30 VDC Power (3-wire) 115 VAC Power (4-wire) 230 VAC Power (4-wire)	200 300 400 430
Maximum Range:	17 ft (5.2 m) 33 ft (10.1 m) 50 ft (15.2 m) 100 ft (30.5 m)	017 033 050 100
Frequency:	5.8 GHz 6.3 GHz 6.3 / 26 GHz	R5 R6 R6R2
Communication:	HART RS232 RS485	CH C2 C4
Enclosure:	Aluminum SS316L	AL SS
Antenna:	Teflon Rod 10" (extendable) Teflon Rod 12"	ATE ATL
Process Connection:	Teflon Decoupler 2" NPT Teflon Decoupler 3" NPT	H20 H30

Dimensions

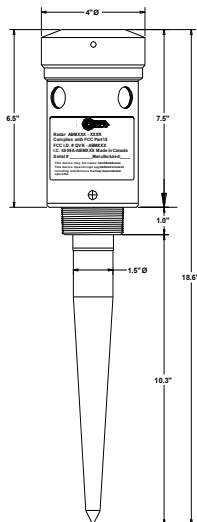

Model:	ABM	- - -	-	- - -	- -	- -	-	- -	- - -	- - -
---------------	-----	-------	---	-------	-----	-----	---	-----	-------	-------

Non-Contact Radar Level Sensors for Very High Temperature Applications | R-VHT



The R-VHT pulse radar level sensor is the ideal solution for liquid, slurry or solid level applications with vapours, gases, foaming or volatile surfaces in very high temperature processes.

Features

- Three thermal barriers to withstand temperatures up to 300°C (572°F)
- SS316L horn antenna with 8" bottom flange and thermal gasket
- Maintenance-free, non-contact continuous level measurements
- Plug-and-play installation with simple calibration
- 3-wire or 4-wire operation
- 4-20 mA / 20-4 mA output standard
- Optional RS232 or RS485 communications with free calibration, diagnostics and data logging software
- PLC compatible (Modbus RTU)
- Aluminum and SS316L housing options to withstand any environment
- Ingress protection IP68 rating (NEMA 6)



Applications

Liquid and solid level measurement for: Chemical, Petrochemical, Asphalt, Molten Metal and more.

Technical Data	
Measuring Range:	Up to 100 ft (30.5 m)
Temperature:	-40 to 300°C (-40 to 572°F)
Pressure Rating:	≤ 2 Bar (29 psi)
Mounting:	8" flange

Catalogue Number Ordering		
Supply Voltage:	12-30 VDC Power (3-wire) 115 VAC Power (4-wire) 230 VAC Power (4-wire)	300 400 430
Maximum Range:	17 ft (5.2 m) 33 ft (10.1 m) 50 ft (15.2 m) 100 ft (30.5 m)	017 033 050 100
Frequency:	5.8 GHz 6.3 GHz 6.3 / 26 GHz	R5 R6 R6R2
Communication:	RS232 RS485	C2 C4
Enclosure:	Aluminum SS316L	AL SS
Antenna:	SS316L Horn 6"	HR6
Process Connection:	Flange 8" w/ Thermal Gasket	BF8

Dimensions

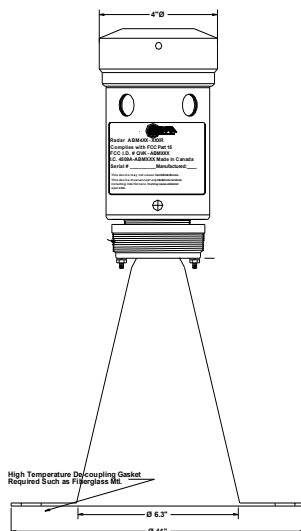

Model:	ABM	- - -	-	- - -	- -	- -	-	- -	HR6	BF8
---------------	-----	-------	---	-------	-----	-----	---	-----	-----	-----

Non-Contact Radar Level Sensors for High Pressure Applications | R-HPR



The R-HPR pulse radar level sensor is the ideal solution for liquid, slurry or solid level applications with vapours, gases, foaming or volatile surfaces in high pressure processes.

Features

- Withstands process pressure up to 70 bar (1015 psi)
- Non-contact continuous level measurements
- Maintenance-free operation with build-up resistant Teflon antenna
- Plug-and-play installation with simple calibration
- 3-wire or 4-wire operation
- 4-20 mA / 20-4 mA output standard
- Optional RS232 or RS485 communications with free calibration, diagnostics and data logging software
- PLC compatible (Modbus RTU)
- Aluminum and SS316L housing options to withstand any environment
- Ingress protection IP68 rating (NEMA 6)



Applications

Liquid and solid level measurement for: Chemical, Food, Beverage and more.

Technical Data	
Measuring Range:	Up to 100 ft (30.5 m)
Temperature:	-40 to 177°C (-40 to 350°F)
Pressure Rating:	≤ 70 Bar (1015 psi)
Mounting:	2" NPT

Catalogue Number Ordering		
Supply Voltage:	12-30 VDC Power (3-wire) 115 VAC Power (4-wire) 230 VAC Power (4-wire)	300 400 430
Maximum Range:	17 ft (5.2 m) 33 ft (10.1 m) 50 ft (15.2 m) 100 ft (30.5 m)	017 033 050 100
Frequency:	5.8 GHz 6.3 GHz	R5 R6
Communication:	RS232 RS485	C2 C4
Enclosure:	Aluminum SS316L	AL SS
Antenna:	High Pressure Teflon Rod	ATP

Dimensions

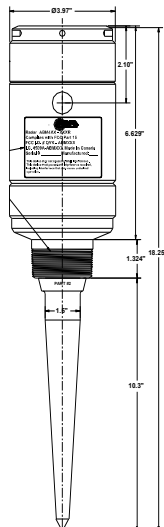

Model:	ABM	-	-	-	-	-	-	-	-	ATP
---------------	-----	---	---	---	---	---	---	---	---	-----

Non-Contact Radar Level Sensors (Continuous Power) for Remote Monitoring | R-RM



The R-RM pulse radar level sensor is the ideal solution for remote level applications in challenging environments with vapours, gases, foaming, ice or volatile surfaces.

Features

- Built-in cellular modem for remote communication and monitoring
- Maintenance-free, non-contact continuous level measurements
- Build-up resistant Teflon rod antenna or SS316L horn antenna options
- Plug-and-play installation with simple remote setup
- 3-wire operation with 4-20 mA / 20-4 mA output standard
- Sensor Access Website for measurement history, calibration and diagnostics
- 24/7 remote active control support from ABM engineers
- Side mount or detached magnetic mount cellular antenna options
- Aluminum and SS316L housing options to withstand any environment
- Ingress protection IP68 rating (NEMA 6)



Applications

Level measurement for: Water, Wastewater, Petrochemical, Environmental and more.

Technical Data	
Measuring Range:	Up to 340 ft (103.6 m)
Temperature:	-40 to 80°C (-40 to 176°F)
Pressure Rating:	≤ 5 Bar (72.5 psi)
Mounting:	1.5" or 2" NPT with rod antenna 3" NPT with horn antenna

Catalogue Number Ordering		
Supply Voltage:	12-30 VDC Power (3-wire)	300
Maximum Range:	17 ft (5.2 m)	017
	33 ft (10.1 m)	033
	50 ft (15.2 m)	050
	100 ft (30.5 m)	100
	140 ft (42.7 m)	140
Frequency:	240 ft (73.2 m)	240
	340 ft (103.6 m)	340
	5.8 GHz	R5
Communication:	6.3 GHz	R6
	6.3 / 26 GHz	R6R2
Enclosure:	Cellular Modem	CM
Antenna:	Aluminum	AL
	SS316L	SS
Antenna:	Teflon Rod 10" (extendable)	ATE
	Teflon Rod 12"	ATL
	SS316L Horn 6"	HR6

Dimensions

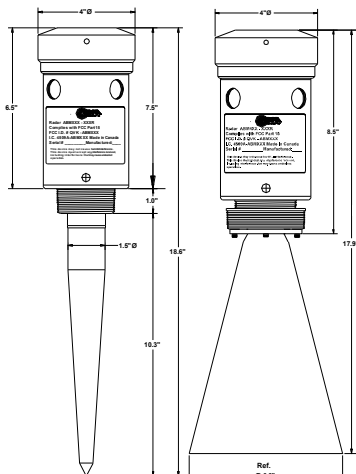

Model:	ABM	300	-	--	--	CM	-	--	---
---------------	-----	-----	---	----	----	----	---	----	-----

Non-Contact Radar Level Sensors (Battery or Solar Panel) for Wireless Remote Monitoring | R-RMB



The low-power R-RMB pulse radar level sensor is the ideal solution for remote level applications in challenging environments with vapours, gases, foaming, ice or volatile surfaces.

Features

- Built-in cellular modem for remote communication and monitoring
- Battery or solar panel power operation
- Internal or external battery pack options
- Maintenance-free, non-contact level measurements
- Build-up resistant Teflon rod antenna or SS316L horn antenna options
- Plug-and-play installation with simple remote setup
- Sensor Access Website for measurement history, calibration and diagnostics
- 24/7 remote active control support from ABM engineers
- Side mount or magnetic mount cellular antenna options
- Aluminum and SS316L housing options to withstand any environment
- Ingress protection IP68 rating (NEMA 6)



Applications

Level measurement for: Water, Wastewater, Petrochemical, Environmental and more.

Technical Data	
Measuring Range:	Up to 340 ft (103.6 m)
Temperature:	-40 to 80°C (-40 to 176°F)
Pressure Rating:	≤ 5 Bar (72.5 psi)
Mounting:	1.5" or 2" NPT with rod antenna 3" NPT with horn antenna

Catalogue Number Ordering		
Supply Voltage:	12-30 VDC Power (Battery)	100
Maximum Range:	17 ft (5.2 m) 33 ft (10.1 m) 50 ft (15.2 m) 100 ft (30.5 m) 140 ft (42.7 m) 240 ft (73.2 m) 340 ft (103.6 m)	017 033 050 100 140 240 340
Frequency:	5.8 GHz 6.3 GHz 6.3 / 26 GHz	R5 R6 R6R2
Communication:	Cellular Modem	CM
Enclosure:	Aluminum SS316L	AL SS
Antenna:	Teflon Rod 10" (extendable) Teflon Rod 12" SS316L Horn 6"	ATE ATL HR6
Battery Pack:	Internal 11AA Holder External 8D Enclosure External 18D Enclosure	AA 8D 18D

Dimensions

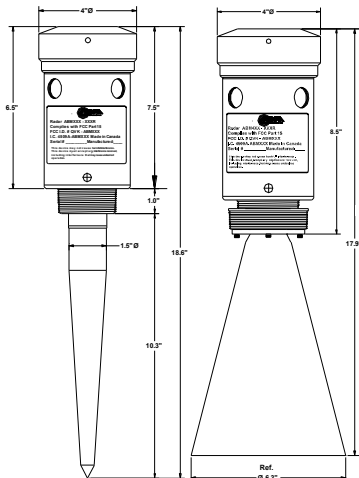

Model:	ABM	100	-	- - -	- -	CM	-	- -	- - - -	- - - -
---------------	-----	-----	---	-------	-----	----	---	-----	---------	---------

Non-Contact Radar Level Sensors for Flood Monitoring Applications | R-FM



The R-FM dual frequency pulse radar level sensor is the ideal solution for liquid level flood monitoring applications with temperature variations, extreme temperatures, rain or wind.

Features

- Low-power consumption ideal for solar panels
- Maintenance-free, non-contact continuous level measurements
- Dual frequency radar with SS316L horn antenna
- Plug-and-play installation with simple calibration
- 2-wire loop-powered or 3-wire operation
- 4-20 mA / 20-4 mA output standard
- Optional HART, RS232 or RS485 communications with free calibration, diagnostics and data logging software
- PLC compatible (Modbus RTU)
- Aluminum and SS316L housing options to withstand any environment
- Ingress protection IP68 rating (NEMA 6)



Applications

Liquid level measurement for: Environmental, Water, Wastewater and more.

Technical Data	
Measuring Range:	Up to 340 ft (103.6 m)
Temperature:	-40 to 80°C (-40 to 176°F)
Pressure Rating:	≤ 5 Bar (72.5 psi)
Mounting:	3" NPT

Catalogue Number Ordering		
Supply Voltage:	16-30 VDC Loop-Powered (2-wire) 12-30 VDC Power (3-wire)	200 300
Maximum Range:	17 ft (5.2 m) 33 ft (10.1 m) 50 ft (15.2 m) 100 ft (30.5 m) 140 ft (42.7 m) 240 ft (73.2 m) 340 ft (103.6 m)	017 033 050 100 140 240 340
Frequency:	6.3 / 26 GHz	R6R2
Communication:	HART RS232 RS485	CH C2 C4
Enclosure:	Aluminum SS316L	AL SS
Antenna:	SS316L Horn 6"	HR6

Dimensions

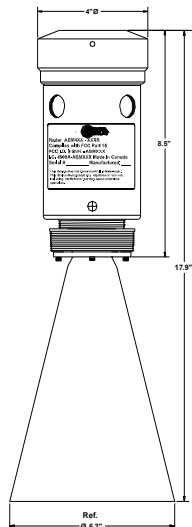

Model:	ABM	-	-	-	-	-	-	-	-	-	Solar Panel
---------------	-----	---	---	---	---	---	---	---	---	---	-------------

Non-Contact Radar Level Sensors for Fast Response Marine Applications | R-FR



The R-FR pulse radar level sensor is the ideal solution for liquid level applications that require fast response in challenging marine environments.

Features

- Fast response 10-30 echoes per second
- Maintenance-free, non-contact continuous level measurements
- Corrosion-resistant SS316L enclosure and horn antenna for marine environments
- Plug-and-play installation with simple calibration
- 3-wire operation
- 4-20 mA / 20-4 mA output standard
- Optional RS232 or RS485 communications with free calibration, diagnostics and data logging software
- PLC compatible (Modbus RTU)
- Ingress protection IP68 rating (NEMA 6)



Applications

Level measurement for: Marine, Environmental, Water, Wastewater and more.

Technical Data	
Measuring Range:	Up to 340 ft (103.6 m)
Temperature:	-40 to 80°C (-40 to 176°F)
Pressure Rating:	≤ 5 Bar (72.5 psi)
Mounting:	3" NPT

Catalogue Number Ordering		
Supply Voltage:	12-30 VDC Power (3-wire)	300
Maximum Range:	17 ft (5.2 m) 33 ft (10.1 m) 50 ft (15.2 m) 100 ft (30.5 m) 140 ft (42.7 m) 240 ft (73.2 m) 340 ft (103.6 m)	017 033 050 100 140 240 340
Frequency:	5.8 GHz 6.3 GHz	R5 R6
Communication:	RS232 RS485	C2 C4
Enclosure:	SS316L	SS
Antenna:	SS316L Horn 6"	HR6

Dimensions

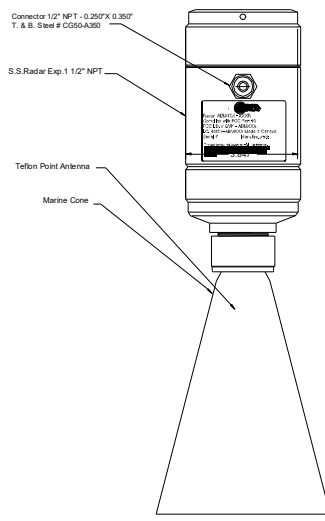

Model:	ABM	300	-	- - -	- -	- -	-	SS	HR6
---------------	-----	-----	---	-------	-----	-----	---	----	-----

Non-Contact Radar Level Sensors for Anti-Collision Applications | R-AC



The R-AC radar system is the ideal solution for anti-collision applications with cranes, vehicles or other machinery.

Features

- Two radar sensors operating at different frequencies
- Very fast response (up to 20 updates per second)
- Maintenance-free, non-contact continuous level measurements
- Plug-and-play installation with simple calibration
- 3-wire operation with 4-20 mA / 20-4 mA output standard
- RS485 communications with free calibration, diagnostics and data logging software
- PLC compatible (Modbus RTU)
- Aluminum and SS316L housing options to withstand any environment
- Ingress protection IP68 rating (NEMA 6)



Applications

Distance measurement for: Construction, Steel, Power Generation, Shipping, and Mining.

Technical Data	
Measuring Range:	Up to 240 ft (73.2 m)
Temperature:	-40 to 80°C (-40 to 176°F)
Pressure Rating:	≤ 5 Bar (72.5 psi)
Mounting:	3" NPT and 2" NPT

Catalogue Number Ordering		
Supply Voltage:	12-30 VDC Power (3-wire)	300
Maximum Range:	17 ft (5.2 m)	017
	33 ft (10.1 m)	033
	50 ft (15.2 m)	050
	100 ft (30.5 m)	100
	140 ft (42.7 m)	140
Frequency:	6.3 GHz (Radar #1)	R6
	26 GHz (Radar #2)	R2
Communication:	RS485	C4
Enclosure:	Aluminum	AL
	SS316L	SS
Antenna:	SS316L Horn 6"	HR6
	SS316L Horn 5"	HR5

Dimensions

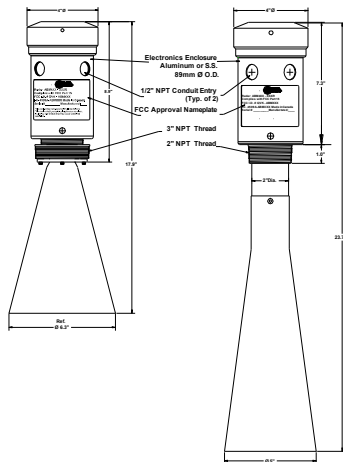

Model #1:	ABM	300	-	---	R6	C4	-	--	HR6	-	CRANE
Model #2:	ABM	300	-	---	R2	C4	-	--	HR5	-	CRANE

Ultrasonic Applications



Liquid Level Monitoring

To monitor stable liquids with no gases or volatile surfaces. Pick a sensor with the range for your application. This will determine the frequency of your sensor. For corrosive applications the transducer material can be chosen that is compatible with the liquid.

Solid Material Level Monitoring

To monitor solid material; the lower operating frequency helps to penetrate dusty the atmosphere found in solids level storage vessels, tanks and bins. They are usually larger in size and require the larger and more powerful transducers for reliable measurement.

High Temperature Applications

To monitor applications with elevated temperatures sensor material selection is important. Special sensor design with thermal isolation is required. Temperature in environment does not effect the ABM sensors performance, because of special and innovative construction of the sensor's drivers.

Sanitary / Hygienic Applications

For sanitary applications ABM provides continuous ultrasonic sensors with 1.5" and 2" tri-clamp mounting. For the food industry the sensor must withstand steam cleaning or clean-in-place (CIP), be quickly removable, and easy to re-install. For high pressure and/or temperature applications, the sensors are available with custom stainless steel transducer.

Remote Monitoring Applications

Remote non-contact ultrasonic level sensors have a built-in cellular modem for remote communication and ABM support. Continuous power and battery or solar panel power (wireless) options are available.

Fast Response Applications

Monitoring fast moving objects is possible with the revolutionary fast response protocol design. ABM ultrasonic sensors measure 10-30 echoes per second, allowing for measurement of any solid material profile.

Liquid-Solid Interface Detection

Monitoring the interface between liquids and solids using the submersible ultrasonic level sensor matched to water. The sensor can be used to monitor the sand, sludge or sediment level at the bottom of the tank or pond.

Ultrasonic Level Sensors and Switches

ABM's ultrasonic technologies are applied to non-contact continuous level sensors matched to air, submersible continuous level sensors matched to water and non-invasive point level switches.

Non-Contact Ultrasonic Level Sensors and Mini Ultrasonic Level Transmitters

An ultrasonic pulse is transmitted from the sensor. The pulse travels through air to the surface being monitored and is reflected off the surface back to the sensor. The time-of-flight is divided by two, corrected with temperature, and converted to an output signal directly proportional to the material level.

Ultrasonic is the ideal solution for measuring the level of liquids or solids without gases or vapours such as CO₂, CO, H₂S, H₂. Select a mini ultrasonic model for short range liquid applications measuring small tanks, drums, totes, barrels or weirs.

Family	Application	Maximum Range	Frequency	Temperature	Pressure	Transducer	Mounting
UL-LIQ	Liquids	Up to 100 ft (30.5 m)	25, 45, 52, 70, 80, 81 or 148 kHz	-40 to 60°C (-40 to 140°F)	≤ 2 Bar (29 psi)	PVC or Teflon	1" - 6" NPT
UL-SLD	Solid Material	Up to 100 ft (30.5 m)	25 or 45 kHz	-40 to 60°C (-40 to 140°F)	≤ 2 Bar (29 psi)	PVC or Teflon	1" - 6" NPT
UL-SAN	Sanitary / Hygienic	Up to 30 ft (9.1 m)	70, 80, 81 or 148 kHz	-40 to 130°C (-40 to 266°F)	≤ 5 Bar (72.5 psi)	SS316L	1.5" or 2" Tri-Clamp
UL-HT	High Temperature / Corrosion Resistant	Up to 60 ft (18.2 m)	45, 52, 70, 80, 81 or 148 kHz	-40 to 130°C (-40 to 266°F)	≤ 2 Bar (29 psi)	Teflon	1" - 3" NPT
UL-RM	Remote Monitoring (continuous power)	Up to 60 ft (18.2 m)	45, 52, 70, 80, 81 or 148 kHz	-40 to 60°C (-40 to 140°F)	≤ 2 Bar (29 psi)	PVC, Teflon or SS316L	1" - 3" NPT
UL-RMB	Remote Monitoring (battery or solar panel)	Up to 60 ft (18.2 m)	45, 52, 70, 80, 81 or 148 kHz	-40 to 60°C (-40 to 140°F)	≤ 2 Bar (29 psi)	PVC, Teflon or SS316L	1" - 3" NPT
UL-FR	Fast Response (2-wire loop-powered)	Up to 100 ft (30.5 m)	25, 45, 52, 70, 80, 81 or 148 kHz	-40 to 60°C (-40 to 140°F)	≤ 2 Bar (29 psi)	PVC	1" - 6" NPT
UL-RT	Extreme Temperature	Up to 60 ft (18.2 m)	45, 52, 70, 80, 81 or 148 kHz	-40 to 130°C (-40 to 266°F)	≤ 2 Bar (29 psi)	Teflon (detached)	1" - 3" NPT

Mini Family	Application	Maximum Range	Frequency	Temperature	Pressure	Transducer	Mounting
UM-LIQ	Liquids	Up to 50 ft (15.2 m)	52, 70, 80, 81 or 148 kHz	-40 to 60°C (-40 to 140°F)	≤ 2 Bar (29 psi)	PVC	1", 1.5" or 2" NPT
UM-SAN	Sanitary / Hygienic	Up to 33 ft (10.1 m)	70, 80, 81 or 148 kHz	-40 to 130°C (-40 to 266°F)	≤ 5 Bar (72.5 psi)	SS316L	1.5" or 2" Tri-Clamp
UM-HT	High Temperature / Corrosion Resistant	Up to 50 ft (15.2 m)	52, 70, 80, 81 or 148 kHz	-40 to 130°C (-40 to 266°F)	≤ 2 Bar (29 psi)	Teflon	1", 1.5" or 2" NPT
UM-SB	Short Blanking	Up to 6 ft (1.8 m)	148 kHz	-40 to 60°C (-40 to 140°F)	≤ 2 Bar (29 psi)	PVC	1" NPT

Submersible Ultrasonic Level Sensor

An ultrasonic pulse matched to water is transmitted from the sensor. The pulse travels through water to the surface being monitored and is reflected off the surface back to the sensor. The time-of-flight is divided by two, corrected with temperature and converted to an output signal directly proportional to the material level.

ABM's submersible ultrasonic is ideal for solid layer detection underwater, underwater pump control and interface detection.

Family	Application	Maximum Range	Frequency	Temperature	Pressure	Transducer	Mounting
UMM-LIQ	Liquids	Up to 40 ft (12.2 m)	148 kHz	-40 to 60°C (-40 to 140°F)	≤ 5 Bar (72.5 psi)	Teflon	Clamp

Non-Invasive Ultrasonic Level Switch

The switch emits a short burst of ultrasonic energy. The energy is coupled through a rubber membrane to the tank causing the tank to vibrate. The tank vibrations are detected and analysed by the switch. Based on the vibration patterns the switch is able to detect the presence or absence of liquid inside the tank, directly opposite the switch.

The switch is ideal for non-invasive point level measurement of liquids in plastic or metal tanks.

Family	Application	Frequency	Temperature	Transducer	Mounting
US-LIQ	Liquids	148 kHz	-40 to 60°C (-40 to 140°F)	PVC	Magnetic Flange or Ratchet Strap
US-HT	High Temperature	148 kHz	-40 to 130°C (-40 to 266°F)	Teflon	Magnetic Flange or Ratchet Strap
US-HP	High Pressure / Thick Wall Tanks	148 kHz	-40 to 60°C (-40 to 140°F)	PVC or Teflon	Magnetic Flange or Ratchet Strap

Non-Contact Ultrasonic Level Sensors for Liquid Applications | UL-LIQ



The UL-LIQ ultrasonic level sensor is the ideal solution for liquid level applications without vapours or gases.

Features

- Maintenance-free, non-contact continuous level measurements
- Self-cleaning design, no build-up or condensation on transducer face
- Plug-and-play installation with simple calibration
- Built-in temperature compensation
- 2-wire loop-powered, 3-wire or 4-wire operation
- 4-20 mA / 20-4 mA output standard
- Optional HART, RS232 or RS485 communications with free calibration, diagnostics and data logging software
- PLC compatible (Modbus RTU)
- PVC, aluminum and SS316L housing options to withstand any environment
- Ingress protection IP68 rating (NEMA 6)



Applications

Liquid level measurement for: Water, Wastewater, Chemical, Food, Beverage and more.

Technical Data	
Measuring Range:	0.4 to 100 ft (0.12 to 30.5 m)
Temperature:	-40 to 60°C (-40 to 140°F)
Pressure Rating:	≤ 2 Bar (29 psi)
Mounting:	1" - 6" NPT

Catalogue Number Ordering		
Supply Voltage:	12-30 VDC Loop-Powered (2-wire) 12-30 VDC Power (3-wire) 120 VAC Power (4-wire) 230 VAC Power (4-wire)	200 300 400 430
Maximum Range:	9 ft (2.7 m) - 148 kHz 16 ft (4.9 m) - 81 kHz 20 ft (6.1 m) - 80 kHz 30 ft (9.1 m) - 70 kHz 50 ft (15.2 m) - 52 kHz 60 ft (18.2 m) - 45 kHz 100 ft (30.5 m) - 25 kHz	148 081 080 070 052 045 148
Product Series:	Ultrasonic Sensor	UL
Communication:	HART RS232 RS485	CH C2 C4
Enclosure:	PVC Aluminum SS316L	PV AL SS
Transducer:	PVC Teflon	PVC TEF

Dimensions

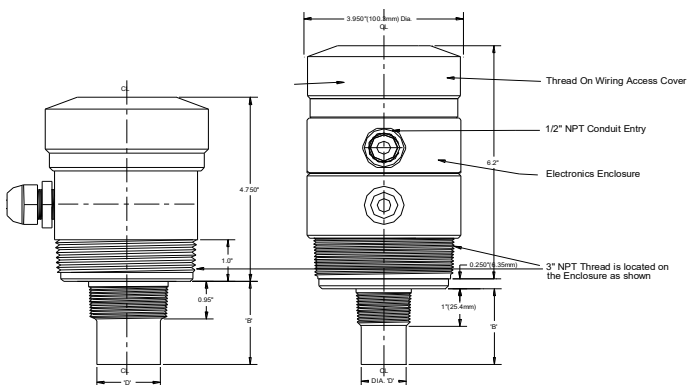

Model:	ABM	-	-	-	UL	-	-	-	-
---------------	-----	---	---	---	----	---	---	---	---

Non-Contact Ultrasonic Level Sensors for Solid Material Applications | UL-SLD



The UL-SLD ultrasonic level sensor is the ideal solution for solid material level applications with dust and steep angle of repose.

Features

- Maintenance-free, non-contact continuous level measurements
- Self-cleaning design, no build-up on transducer face
- Plug-and-play installation with simple calibration
- Built-in temperature compensation
- 2-wire loop-powered, 3-wire or 4-wire operation
- 4-20 mA / 20-4 mA output standard
- Optional HART, RS232 or RS485 communications with free calibration, diagnostics and data logging software
- PLC compatible (Modbus RTU)
- PVC, aluminum and SS316L housing options to withstand any environment
- Ingress protection IP68 rating (NEMA 6)



Applications

Solid level measurement for: Plastics, Cement, Animal Feed, and more.

Technical Data	
Measuring Range:	0.4 to 100 ft (0.12 to 30.5 m)
Temperature:	-40 to 60°C (-40 to 140°F)
Pressure Rating:	≤ 2 Bar (29 psi)
Mounting:	1" - 6" NPT

Catalogue Number Ordering		
Supply Voltage:	12-30 VDC Loop-Powered (2-wire)	200
	12-30 VDC Power (3-wire)	300
	120 VAC Power (4-wire)	400
	230 VAC Power (4-wire)	430
Maximum Range:	60 ft (18.2 m) - 45 kHz	045
	100 ft (30.5 m) - 25 kHz	025
Product Series:	Ultrasonic Sensor	UL
Communication:	HART	CH
	RS232	C2
	RS485	C4
Enclosure:	PVC	PV
	Aluminum	AL
	SS316L	SS
Transducer:	PVC	PVC
	Teflon (045 only)	TEF

Dimensions

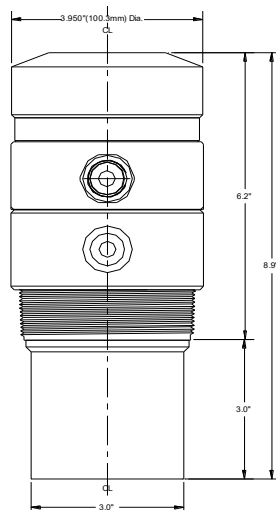

Model:	ABM	- - - -	-	- - - -	UL	- -	-	- -	- - - -
---------------	-----	---------	---	---------	----	-----	---	-----	---------

Non-Contact Ultrasonic Level Sensors for Sanitary Applications | UL-SAN



The UL-SAN ultrasonic level sensor is the ideal solution for hygienic liquid, slurry or solid level applications.

Features

- SS316L transducer face with 1.5" or 2" tri-clamp mounting
- Surface finish exposed to process exceeds a No.4 / dairy finish
- Withstands clean-in-place (CIP) processes with high temp. / pressure upgrade
- Maintenance-free, non-contact continuous level measurements
- Self-cleaning design, no build-up or condensation on transducer face
- Plug-and-play installation with simple calibration
- Built-in temperature compensation
- 2-wire loop-powered, 3-wire or 4-wire operation with 4-20 mA / 20-4 mA output standard
- Optional HART, RS232 or RS485 communications with free calibration, diagnostics and data logging software. PLC compatible (Modbus RTU)
- PVC, aluminum and SS316L housing options to withstand any environment
- Ingress protection IP68 rating (NEMA 6)



Applications

Level measurement for: Food, Beverage, Pharmaceutical, Water and more.

Technical Data	
Measuring Range:	0.4 to 30 ft (0.12 to 9.1 m)
Temperature:	-40 to 60°C (-40 to 140°F) or -40 to 130°C (-40 to 266°F) with HTP
Pressure Rating:	≤ 2 Bar (29 psi) or ≤ 5 Bar (72.5 psi) with HTP
Mounting:	1.5" or 2" tri-clamp

Catalogue Number Ordering		
Supply Voltage:	12-30 VDC Loop-Powered (2-wire) 12-30 VDC Power (3-wire) 120 VAC Power (4-wire) 230 VAC Power (4-wire)	200 300 400 430
Maximum Range:	9 ft (2.7 m) - 148 kHz 16 ft (4.9 m) - 81 kHz 20 ft (6.1 m) - 80 kHz 30 ft (9.1 m) - 70 kHz	148 081 080 070
Product Series:	Ultrasonic Sensor	UL
Communication:	HART RS232 RS485	CH C2 C4
Enclosure:	PVC Aluminum SS316L	PV AL SS
Transducer:	SS316L 1.5" Tri-Clamp SS316L 2" Tri-Clamp	S15 S20
Optional:	High Temperature and Pressure	HTP

Dimensions

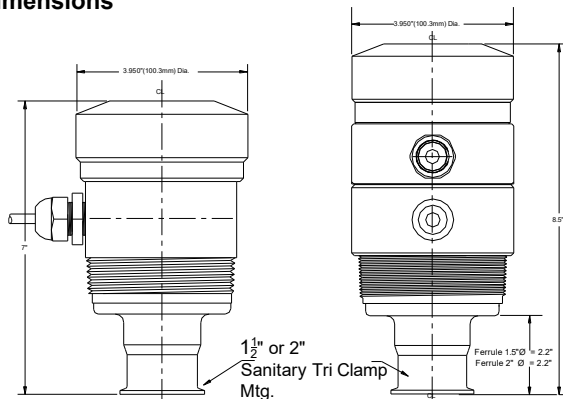

Model:	ABM	-	-	-	UL	-	-	-	-	-
---------------	-----	---	---	---	----	---	---	---	---	---

Non-Contact Ultrasonic Level Sensors for High Temperature Applications | UL-HT



The UL-HT ultrasonic level sensor is the ideal solution for liquid level applications in high temperature processes.

Features

- High temperature processes up to 130°C (266°F)
- Maintenance-free, non-contact continuous level measurements
- Self-cleaning design, no build-up or condensation on transducer face
- Plug-and-play installation with simple calibration
- Built-in temperature compensation
- 2-wire loop-powered, 3-wire or 4-wire operation
- 4-20 mA / 20-4 mA output standard
- Optional HART, RS232 or RS485 communications with free calibration, diagnostics and data logging software
- PLC compatible (Modbus RTU)
- PVC, aluminum and SS316L housing options to withstand any environment
- Ingress protection IP68 rating (NEMA 6)



Applications

Liquid and solid level measurement for: Water, Wastewater, Chemical and more.

Technical Data	
Measuring Range:	0.4 to 100 ft (0.12 to 30.5 m)
Temperature:	-40 to 130°C (-40 to 266°F)
Pressure Rating:	≤ 2 Bar (29 psi)
Mounting:	1" - 6" NPT

Catalogue Number Ordering		
Supply Voltage:	12-30 VDC Loop-Powered (2-wire) 12-30 VDC Power (3-wire) 120 VAC Power (4-wire) 230 VAC Power (4-wire)	200 300 400 430
Maximum Range:	9 ft (2.7 m) - 148 kHz 16 ft (4.9 m) - 81 kHz 20 ft (6.1 m) - 80 kHz 30 ft (9.1 m) - 70 kHz 50 ft (15.2 m) - 52 kHz 60 ft (18.2 m) - 45 kHz 100 ft (30.5 m) - 25 kHz	148 081 080 070 052 045 025
Product Series:	Ultrasonic Sensor	UL
Communication:	HART RS232 RS485	CH C2 C4
Enclosure:	PVC Aluminum SS316L	PV AL SS
Transducer:	Teflon	TEF

Dimensions

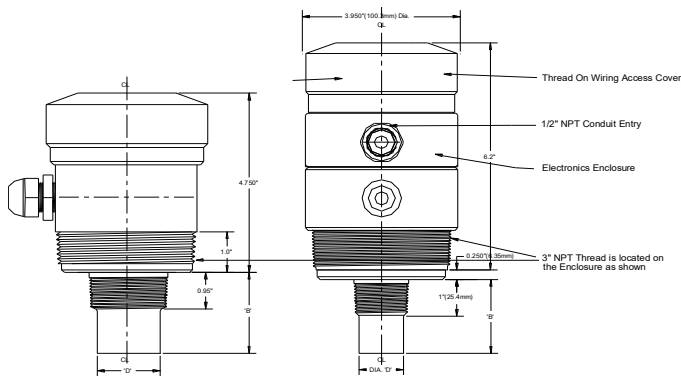

Model:	ABM	-	-	-	UL	-	-	TEF
---------------	-----	---	---	---	----	---	---	-----

Non-Contact Ultrasonic Level Sensors (Continuous Power) for Remote Monitoring | UL-RM



The UL-RM ultrasonic level sensor is the ideal solution for liquid and solids remote monitoring level applications.

Features

- Built-in cellular modem for remote communication and monitoring
- Maintenance-free, non-contact continuous level measurements
- Self-cleaning design, no build-up or condensation on transducer face
- Plug-and-play installation with simple remote setup
- Built-in temperature compensation
- 3-wire operation with 4-20 mA / 20-4 mA output standard
- Sensor Access Website for measurement history, calibration and diagnostics
- Side mount or detached magnetic mount cellular antenna options
- PVC, aluminum and SS316L housing options to withstand any environment
- Ingress protection IP68 rating (NEMA 6)



Applications

Level measurement for: Water, Chemical, Cement, Plastic, Environmental and more.

Technical Data	
Measuring Range:	0.4 to 60 ft (0.12 to 18.2 m)
Temperature:	-40 to 60°C (-40 to 140°F)
Pressure Rating:	≤ 2 Bar (29 psi)
Mounting:	1" - 3" NPT

Catalogue Number Ordering		
Supply Voltage:	12-30 VDC Power (3-wire)	300
Maximum Range:	9 ft (2.7 m) - 148 kHz 16 ft (4.9 m) - 81 kHz 20 ft (6.1 m) - 80 kHz 30 ft (9.1 m) - 70 kHz 50 ft (15.2 m) - 52 kHz 60 ft (18.2 m) - 45 kHz	148 081 080 070 052 045
Product Series:	Ultrasonic Sensor	UL
Communication:	Cellular Modem	CM
Enclosure:	PVC Aluminum SS316L	PV AL SS
Transducer:	PVC Teflon	PVC TEF

Dimensions

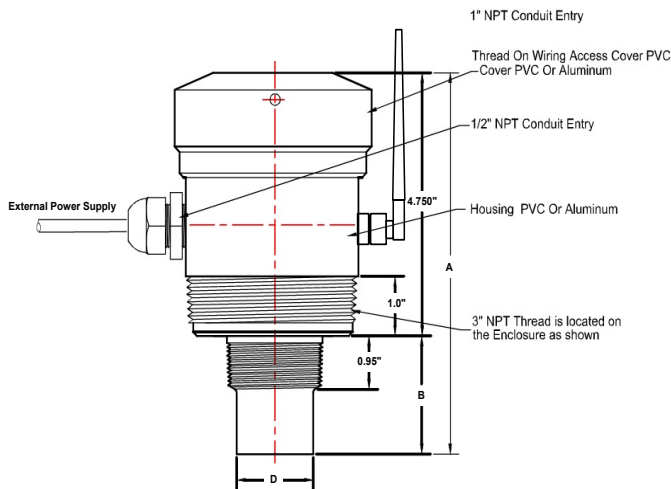

Model:	ABM	300	-	- - -	UL	CM	-	- -	- - -
---------------	-----	-----	---	-------	----	----	---	-----	-------

Non-Contact Ultrasonic Level Sensors (Battery or Solar Panel) for Wireless Remote Monitoring | UL-RMB



The wireless UL-RMB battery powered ultrasonic level sensor is the ideal solution for liquid and solids remote monitoring level applications.

Features

- Battery or solar panel power operation
- Internal or external battery pack options
- Maintenance-free, non-contact level measurements
- Self-cleaning design, no build-up or condensation on transducer face
- Plug-and-play installation with simple remote setup
- Built-in temperature compensation
- Sensor Access Website for measurement history, calibration and diagnostics
- Side mount or detached magnetic mount cellular antenna options
- PVC, aluminum and SS316L housing options to withstand any environment
- Ingress protection IP68 rating (NEMA 6)



Applications

Level measurement for: Water, Chemical, Cement, Plastic, Environmental and more.

Technical Data	
Measuring Range:	0.4 to 60 ft (0.12 to 18.2 m)
Temperature:	-40 to 60°C (-40 to 140°F)
Pressure Rating:	≤ 2 Bar (29 psi)
Mounting:	1" - 3" NPT

Catalogue Number Ordering		
Supply Voltage:	6-30 VDC Power (Battery)	100
Maximum Range:	9 ft (2.7 m) - 148 kHz	148
	16 ft (4.9 m) - 81 kHz	081
	20 ft (6.1 m) - 80 kHz	080
	30 ft (9.1 m) - 70 kHz	070
	50 ft (15.2 m) - 52 kHz	052
	60 ft (18.2 m) - 45 kHz	045
Product Series:	Ultrasonic Sensor	UL
Communication:	Cellular Modem	CM
Enclosure:	PVC	PV
	Aluminum	AL
	SS316L	SS
Transducer:	PVC	PVC
	Teflon	TEF
Battery Pack:	Internal 12AA Holder	AA
	External 8D Enclosure	8D
	External 18D Enclosure	18D

Dimensions

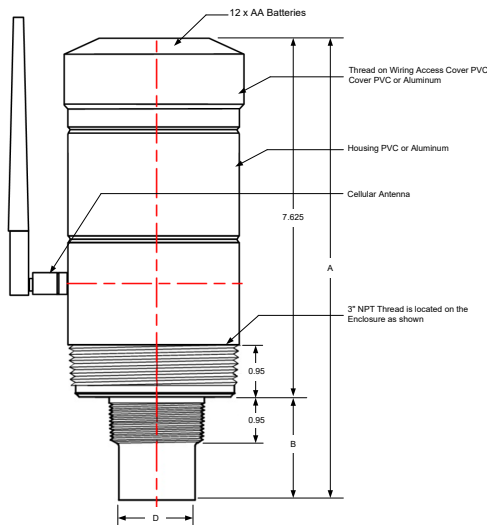

Model:	ABM	100	-	---	UL	CM	-	--	---	-	---
---------------	-----	-----	---	-----	----	----	---	----	-----	---	-----

Non-Contact Ultrasonic Level Sensors (2-Wire Loop-Powered) for Fast Response Applications | UL-FR



The UL-FR is the fastest 2-wire loop-powered ultrasonic level sensor, ideal for liquid or solid level applications that require rapid response.

Features

- At least three (3) updates per second and the fastest HART communication
- Maintenance-free, non-contact continuous level measurements
- Self-cleaning design, no build-up or condensation on transducer face
- Plug-and-play installation with simple calibration
- Built-in temperature compensation
- 2-wire loop-powered operation
- 4-20 mA / 20-4 mA output standard
- HART communications with free calibration, diagnostics and data logging software
- PVC, aluminum and SS316L housing options to withstand any environment
- Ingress protection IP68 rating (NEMA 6)



Applications

Liquid and solid level measurement for: Water, Wastewater, Chemical, Food, Beverage and more.

Technical Data	
Measuring Range:	0.4 to 100 ft (0.12 to 30.5 m)
Temperature:	-40 to 60°C (-40 to 140°F)
Pressure Rating:	≤ 2 Bar (29 psi)
Mounting:	1" - 6" NPT

Catalogue Number Ordering		
Supply Voltage:	12-30 VDC Loop-Powered (2-wire)	200
Maximum Range:	9 ft (2.7 m) - 148 kHz 16 ft (4.9 m) - 81 kHz 20 ft (6.1 m) - 80 kHz 30 ft (9.1 m) - 70 kHz 50 ft (15.2 m) - 52 kHz 60 ft (18.2 m) - 45 kHz 100 ft (30.5 m) - 25 kHz	148 081 080 070 052 045 148
Product Series:	Ultrasonic Sensor	UL
Communication:	HART	CH
Enclosure:	PVC Aluminum SS316L	PV AL SS
Transducer:	PVC Teflon	PVC TEF

Dimensions

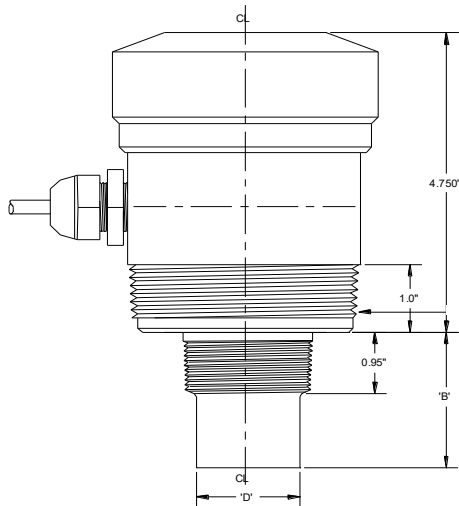

Model:	ABM	200	-	--	UL	CH	-	--	---
---------------	-----	-----	---	----	----	----	---	----	-----

Ultrasonic Transmitter with Remote Transducer for Very High Temperature Applications | UL-RT



The UL-RT ultrasonic transmitter with detached transducer is the ideal solution for liquid and solid level applications in very high temperature environments.

Features

- Transmitter with detached high temperature Teflon transducer (up to 130°C / 266°F)
- Maintenance-free, non-contact continuous level measurements
- Self-cleaning design, no build-up or condensation on transducer face
- Plug-and-play installation with simple calibration
- Built-in temperature compensation
- 2-wire loop-powered, 3-wire or 4-wire operation
- 4-20 mA / 20-4 mA output standard
- Optional HART, RS232 or RS485 communications with free calibration, diagnostics and data logging software
- PLC compatible (Modbus RTU)
- PVC, aluminum and SS316L housing options to withstand any environment
- Ingress protection IP68 rating (NEMA 6)



Applications

Level measurement for: Construction, Chemical, Food, Beverage and more.

Technical Data	
Measuring Range:	0.4 to 60 ft (0.12 to 18.2 m)
Temperature:	-40 to 130°C (-40 to 266°F)
Pressure Rating:	≤ 2 Bar (29 psi)
Mounting:	1" - 2" NPT

Catalogue Number Ordering		
Supply Voltage:	12-30 VDC Loop-Powered (2-wire)	200
	12-30 VDC Power (3-wire)	300
	120 VAC Power (4-wire)	400
	230 VAC Power (4-wire)	430
Maximum Range:	9 ft (2.7 m) - 148 kHz	148
	16 ft (4.9 m) - 81 kHz	081
	20 ft (6.1 m) - 80 kHz	080
	30 ft (9.1 m) - 70 kHz	070
	50 ft (15.2 m) - 52 kHz	052
	60 ft (18.2 m) - 45 kHz	045
Product Series:	Ultrasonic Sensor	UL
Communication:	HART	CH
	RS232	C2
	RS485	C4
Enclosure:	PVC	PV
	Aluminum	AL
	SS316L	SS
Transducer:	Teflon	TEF

Dimensions

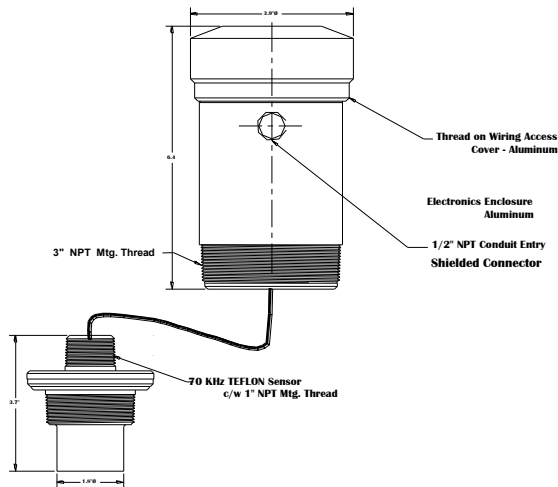

Model:	ABM	- - -	-	- - -	UL	- -	-	- -	TEF
---------------	-----	-------	---	-------	----	-----	---	-----	-----

Non-Contact Mini Ultrasonic Level Transmitters for Liquid Applications | UM-LIQ



The UM-LIQ mini ultrasonic level transmitter is the ideal solution for short range liquid level applications.

Features

- Maintenance-free, non-contact continuous level measurements
- Self-cleaning design, no build-up or condensation on transducer face
- Plug-and-play installation with simple push-button calibration
- Built-in temperature compensation
- 3-wire operation
- 4-20 mA / 20-4 mA output standard
- RS485 communications with free calibration, diagnostics and data logging software
- PLC compatible (Modbus RTU)
- Optional relay SPDT 8A / 230 VAC for alarm or pump control
- Ingress protection IP68 rating (NEMA 6)



Applications

Liquid level measurement for: Water, Wastewater, Chemical, Food, Beverage and more.

Technical Data	
Measuring Range:	0.33 to 50 ft (0.10 to 15.2 m)
Temperature:	-40 to 60°C (-40 to 140°F)
Pressure Rating:	≤ 2 Bar (29 psi)
Mounting:	1", 1.5" or 2" NPT

Catalogue Number Ordering		
Supply Voltage:	12-30 VDC Power (3-wire)	300
Maximum Range:	6 ft (1.8 m) - 148 kHz	148
	16 ft (4.9 m) - 81 kHz	081
	20 ft (6.1 m) - 80 kHz	080
	33 ft (10.1 m) - 70 kHz	070
	50 ft (15.2 m) - 52 kHz	052
Product Series:	Mini Ultrasonic Transmitter	UM
Communication:	RS485	C4
Enclosure:	PVC	PV
Transducer:	PVC	PVC

Dimensions

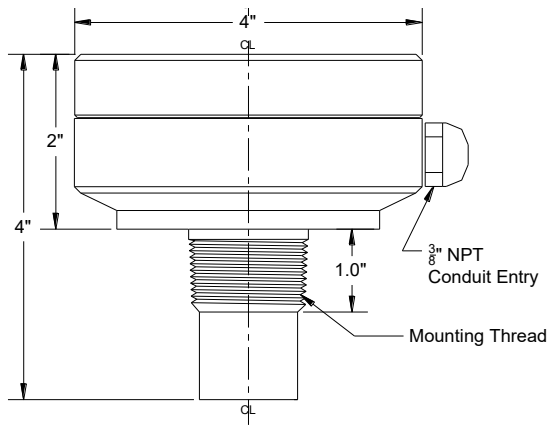

Model:	ABM	300	-	- - -	UM	C4	-	PV	PVC
---------------	-----	-----	---	-------	----	----	---	----	-----

Non-Contact Mini Ultrasonic Level Transmitters for Sanitary Applications | UM-SAN



The UM-SAN mini ultrasonic level transmitter is the ideal solution for short range sanitary / hygienic liquid level applications.

Features

- SS316L transducer face with 1.5" or 2" tri-clamp mounting
- Surface finish exposed to process exceeds a No.4/dairy finish
- Withstands clean-in-place (CIP) processes with high temp. / pressure upgrade
- Maintenance-free, non-contact continuous level measurements
- Self-cleaning design, no build-up or condensation on transducer face
- Plug-and-play installation with simple push-button calibration
- Built-in temperature compensation
- 3-wire operation with 4-20 mA / 20-4 mA output standard
- RS485 communications with free calibration, diagnostics and data logging software
- PLC compatible (Modbus RTU)
- Optional relay SPDT 8A / 230 VAC for alarm or pump control
- Ingress protection IP68 rating (NEMA 6)



Applications

Liquid level measurement for: Water, Food, Beverage, Pharmaceutical and more.

Technical Data	
Measuring Range:	0.33 to 33 ft (0.12 to 9.1 m)
Temperature:	-40 to 60°C (-40 to 140°F) or -40 to 130°C (-40 to 266°F) with HTP
Pressure Rating:	≤ 2 Bar (29 psi) or ≤ 5 Bar (72.5 psi) with HTP
Mounting:	1.5" or 2" tri-clamp

Catalogue Number Ordering		
Supply Voltage:	12-30 VDC Power (3-wire)	300
Maximum Range:	6 ft (1.8 m) - 148 kHz 16 ft (4.9 m) - 81 kHz 20 ft (6.1 m) - 080 kHz 33 ft (10.1 m) - 070 kHz	148 081 080 070
Product Series:	Mini Ultrasonic Transmitter	UM
Communication:	RS485	C4
Enclosure:	PVC	PV
Transducer:	SS316L 1.5" Tri-Clamp SS316L 2" Tri-Clamp	S15 S20
Optional:	High Temperature and Pressure	HTP

Dimensions

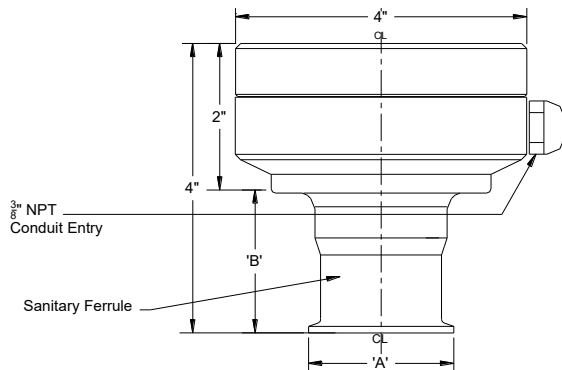

Model:	ABM	300	-	- - -	UM	C4	-	PV	- - -	-	- - -
---------------	-----	-----	---	-------	----	----	---	----	-------	---	-------

Non-Contact Mini Ultrasonic Level Transmitters for High Temperature Applications | UM-HT



The UM-HT mini ultrasonic level transmitter is the ideal solution for short range liquid level applications in high temperature processes.

Features

- High temperature Teflon transducer withstands up to 130°C (266°F)
- Maintenance-free, non-contact continuous level measurements
- Self-cleaning design, no build-up or condensation on transducer face
- Plug-and-play installation with simple push-button calibration
- Built-in temperature compensation
- 3-wire operation with 4-20 mA / 20-4 mA output standard
- RS485 communications with free calibration, diagnostics and data logging software
- PLC compatible (Modbus RTU)
- Optional relay SPDT 8A / 230 VAC for alarm or pump control
- Ingress protection IP68 rating (NEMA 6)



Applications

Liquid level measurement for: Water, Wastewater, Chemical and more.

Technical Data	
Measuring Range:	0.33 to 50 ft (0.10 to 15.2 m)
Temperature:	-40 to 130°C (-40 to 266°F)
Pressure Rating:	≤ 2 Bar (29 psi)
Mounting:	1", 1.5" or 2" NPT

Catalogue Number Ordering		
Supply Voltage:	12-30 VDC Power (3-wire)	300
Maximum Range:	6 ft (1.8 m) - 148 kHz	148
	16 ft (4.9 m) - 81 kHz	081
	20 ft (6.1 m) - 80 kHz	080
	30 ft (9.1 m) - 70 kHz	070
	50 ft (15.2 m) - 52 kHz	052
Product Series:	Mini Ultrasonic Transmitter	UM
Communication:	RS485	C4
Enclosure:	PVC	PV
Transducer:	Teflon	TEF

Dimensions

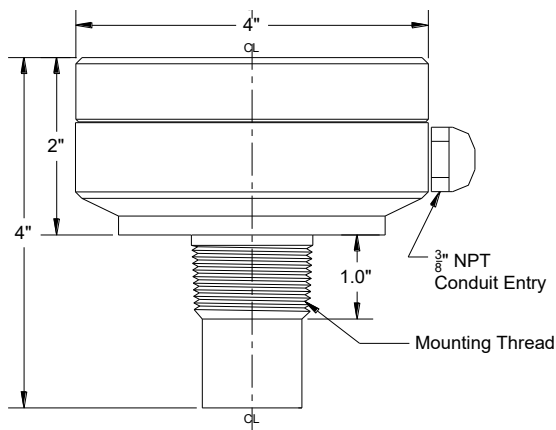

Model:	ABM	300	-	- - -	UM	C4	-	PV	TEF
---------------	-----	-----	---	-------	----	----	---	----	-----

Non-Contact Mini Ultrasonic Level Transmitters for Short Blanking Applications | UM-SB



The UM-SB mini ultrasonic level transmitter is the ideal solution for short range liquid level applications that require minimal blanking distance.

Features

- Short blanking distance of 2" (50.8 mm)
- Maintenance-free, non-contact continuous level measurements
- Self-cleaning design, no build-up or condensation on transducer face
- Plug-and-play installation with simple push-button calibration
- Built-in temperature compensation
- 3-wire operation with 4-20 mA / 20-4 mA output standard
- RS485 communications with free calibration, diagnostics and data logging software
- PLC compatible (Modbus RTU)
- Optional relay SPDT 8A / 230 VAC for alarm or pump control
- Ingress protection IP68 rating (NEMA 6)



Applications

Liquid level measurement for: Water, Wastewater, Chemical and more.

Technical Data	
Measuring Range:	0.16 to 6 ft (0.05 to 1.8 m)
Temperature:	-40 to 60°C (-40 to 140°F)
Pressure Rating:	≤ 2 Bar (29 psi)
Mounting:	1" NPT

Catalogue Number Ordering		
Supply Voltage:	12-30 VDC Power (3-wire)	300
Maximum Range:	6 ft (1.8 m) - 148 kHz	148
Product Series:	Mini Ultrasonic Transmitter	UM
Communication:	RS485	C4
Enclosure:	PVC	PV
Transducer:	PVC	PVC
Special:	Short Blanking	SB

Dimensions

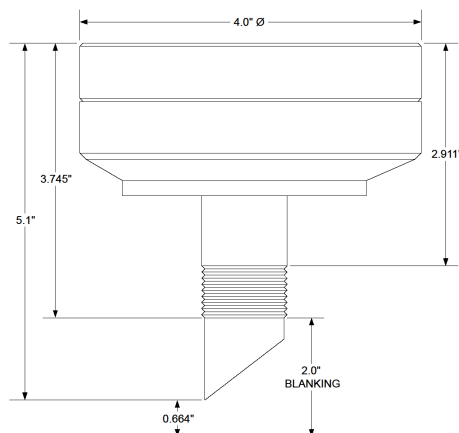

Model:	ABM	300	-	148	UM	C4	-	PV	PVC	-	SB
---------------	-----	-----	---	-----	----	----	---	----	-----	---	----

Submersible Ultrasonic Level Sensor for Liquid Applications | UMM-LIQ



The UMM-LIQ submersible ultrasonic level sensor is the ideal solution for underwater pump control / protection applications and liquid-solid interface detection.

Features

- Underwater continuous level measurements
- Self-cleaning, automatic removal of air bubbles from transducer face
- SS316L housing with Teflon transducer face
- Clamp mount installation with simple two point calibration
- Built-in temperature compensation
- 3-wire operation
- 4-20 mA / 20-4 mA output standard
- RS485 communication with free calibration, diagnostics and data logging software
- PLC compatible (Modbus RTU)



Applications

Liquid level measurement for: Wastewater, Environmental, Automotive, Oil and more.

Technical Data		Catalogue Number Ordering		
Measuring Range:	0.7 to 40 ft (0.45 to 12.2 m)	Supply Voltage:	12-30 VDC Power (3-wire)	300
Resolution:	0.03 inches (0.7 mm)	Maximum Range:	40 ft (12.2 m) - 148 kHz	148
Temperature:	-40 to 60°C (-40 to 140°F)	Product Series:	Submersible Ultrasonic Sensor	UMM
Pressure Rating:	≤ 5 Bar (72.5 psi)	Communication:	RS485	C4
Mounting:	Clamp	Enclosure:	SS316L	SS
		Transducer:	Teflon	TEF

Dimensions

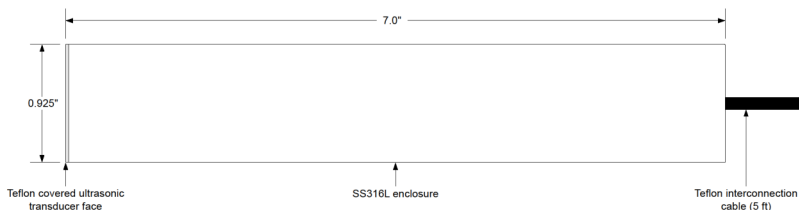

Model:	ABM	300	-	148	UMM	C4	-	SS	TEF
---------------	-----	-----	---	-----	-----	----	---	----	-----

Non-Invasive Ultrasonic Level Switch for Liquid Applications | US-LIQ



The US-LIQ ultrasonic level switch is the ideal solution for any liquid level application that benefits from non-invasive operation (i.e. high pressure, sanitary, high purity, corrosive).

Features

- Maintenance-free non-invasive point level measurements, no cleaning
- Easy to install on metal or plastic tank exterior, no drilling
- No down-time or shut-down during installation
- Simple push-button calibration or free communication software
- 3-wire operation
- RS485 communications with free calibration, diagnostics and data logging software
- SPDT relay output 8A / 230 VAC for alarm or pump control
- Ingress protection IP68 rating (NEMA 6)



Applications

Liquid level measurement for: Water, Chemical, Food, Beverage, Pharmaceutical and more.

Technical Data	
Accuracy:	+/- 1 mm
Temperature:	-40 to 60°C (-40 to 140°F)
Tank Material:	Plastic or metal
Tank Wall Thickness:	0.25" (6 mm) maximum
Mounting:	Flange with ratchet strap or magnetic flange

Catalogue Number Ordering		
Supply Voltage:	12-30 VDC Power (3-wire)	300
Frequency:	148 kHz	148
Product Series:	Ultrasonic Switch	US
Communication:	RS485	C4
Enclosure:	PVC	PV
Transducer:	PVC	PVC

Dimensions

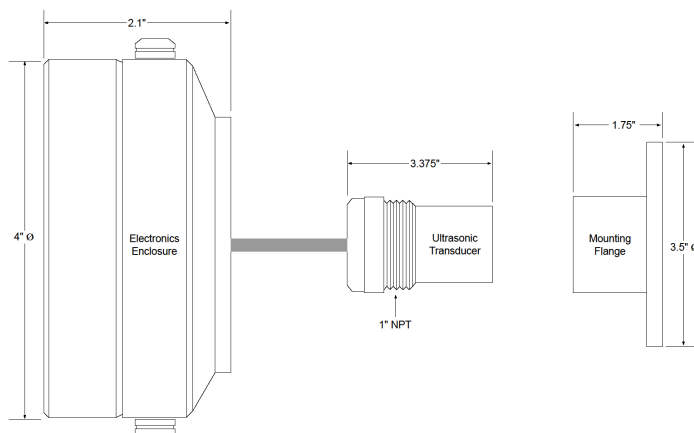

Model:	ABM	300	-	148	US	C4	-	PV	PVC
---------------	-----	-----	---	-----	----	----	---	----	-----

Non-Invasive Ultrasonic Level Switch for High Temperature Applications | US-HT



The US-HT ultrasonic level switch is the ideal solution for any high temperature liquid level application that benefits from non-invasive operation (i.e. high pressure, sanitary, corrosive).

Features

- Teflon transducer for high temperature processes (up to 130°C / 266°F)
- Maintenance-free non-invasive point level measurements, no cleaning
- Easy to install on metal or plastic tank exterior, no drilling
- No down-time or shut-down during installation
- Simple push-button calibration or free communication software
- 3-wire operation
- RS485 communications with free calibration, diagnostics and data logging software
- SPDT relay output 8A / 230 VAC for alarm or pump control
- Ingress protection IP68 rating (NEMA 6)



Applications

Liquid level measurement for: Water, Chemical, Food, Beverage, Pharmaceutical and more.

Technical Data	
Accuracy:	+/- 1 mm
Temperature:	-40 to 130°C (-40 to 266°F)
Tank Material:	Plastic or metal
Tank Wall Thickness:	0.25" (6 mm) maximum
Mounting:	Flange with ratchet strap or magnetic flange

Catalogue Number Ordering		
Supply Voltage:	12-30 VDC Power (3-wire)	300
Frequency:	148 kHz	148
Product Series:	Ultrasonic Switch	US
Communication:	RS485	C4
Enclosure:	PVC	PV
Transducer:	Teflon	TEF

Dimensions

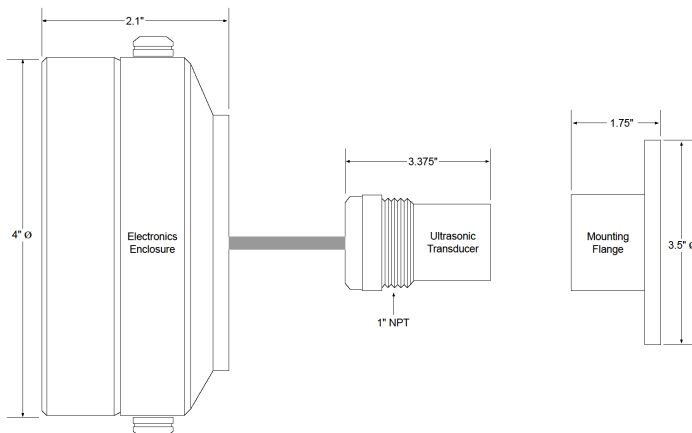

Model:	ABM	300	-	148	US	C4	-	PV	TEF
---------------	-----	-----	---	-----	----	----	---	----	-----

Non-Invasive Ultrasonic Level Switch for High Pressure Applications | US-HPR



The US-HPR ultrasonic level switch is the ideal solution for very thick tank walls and high pressure liquid level applications that benefit from non-invasive operation.

Features

- Operation on very thick metal tank walls (>2") and high pressure processes (>10,000 PSI)
- Maintenance-free non-invasive point level measurements, no cleaning
- Easy to install on metal tank exterior, no drilling
- No down-time or shut-down during installation
- Simple push-button calibration or free communication software
- 3-wire operation
- RS485 communications with free calibration, diagnostics and data logging software
- SPDT relay output 8A / 230 VAC for alarm or pump control
- Ingress protection IP68 rating (NEMA 6)



Applications

Liquid level measurement for: Water, Chemical, Food, Beverage, Pharmaceutical and more.

Technical Data	
Accuracy:	+/- 1 mm
Temperature:	-40 to 130°C (-40 to 266°F)
Tank Material:	Metal
Tank Wall Thickness:	> 2" (50.8 mm)
Mounting:	Flange with ratchet strap or magnetic flange

Catalogue Number Ordering		
Supply Voltage:	12-30 VDC Power (3-wire)	300
Frequency:	148 kHz	148
Product Series:	Ultrasonic Switch	US
Communication:	RS485	C4
Enclosure:	PVC	PV
Transducer:	PVC Teflon (high temperature)	PVC TEF

Dimensions

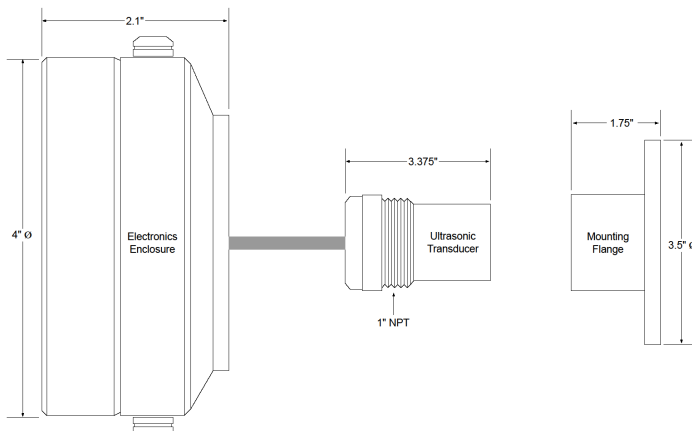

Model:	ABM	300	-	148	US	C4	-	PV	TEF
---------------	-----	-----	---	-----	----	----	---	----	-----

Controllers and Displays

Whether you're monitoring liquid or solid material levels in tanks, reservoirs, or any other industrial application, our range of products ensures seamless data collection and monitoring. Our controllers offer precise control and automation, while our displays provide real-time data for easy interpretation. With our cellular gateways, you can access sensor data remotely, ensuring you're always informed, no matter where you are.

Product	Display	Inputs	Communication	Relay	Supply Voltage
Cellular Gateway	Remote via Sensor Access Website	Eight (8) Sensors with RS485 or One (1) Sensor with RS232	Wireless via Cellular Network	None	12-30 VDC Power
Remote Dry Contact Monitor	Remote via Sensor Access Website	One (1) Dry Relay or Switch Contact	Wireless via Cellular Network	None	12-30 VDC Power
Relay Controller	LCD with LED Indicators	One (1) Sensor with 4-20 mA Output	None	Three (3) or Six (6) Relay	12-30 VDC Power (3-wire) 115 VAC Power (4-wire) 230 VAC Power (4-wire)
Wall Mount Display	3 Digit LCD	One (1) Sensor with 4-20 mA Output	None	None	Loop-Power from Sensor
Sensor Mount Display	4 1/2 Digit LCD	One (1) Sensor with 4-20 mA Output	None	None	Loop-Power from Sensor

Cellular Gateway



The Cellular Gateway enables new or existing ABM level sensors to connect to the ABM servers for remote monitoring, control and 24/7 online virtual support.

Features

- Remote monitoring for any ABM level sensor with RS232 or RS485
- Wireless communication via cellular network
- Web-based ABM Sensor Access portal for monitoring, configuration and alarm via email message setup
- Up to five (5) alarm types per sensor by email application
- Low-power feature for extended battery life
- NEMA 4 / 4X enclosure, suitable for outdoor installation
- Optional explosion proof approvals - Class I Division 1 (CID1)

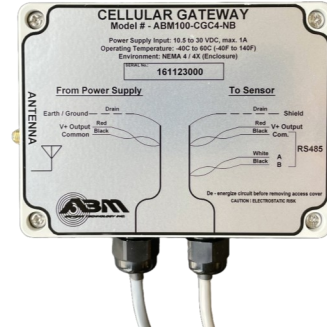

Technical Data	
Input:	Eight (8) sensors with RS485 or one (1) sensor with RS232
Output:	Cellular data transmission to ABM servers
Configuration:	Remote via Sensor Access website
Temperature:	-40 to 60°C (-40 to 140°F)
Antenna:	Detached magnetic base antenna or side mounted antenna
Enclosure:	NEMA 4 / 4X, wall mountable

Catalogue Number Ordering		
Supply Voltage:	10.5-30 VDC Power (Battery) 12-30 VDC Power	100 300
Product:	Cellular Gateway	CG
Communication Input:	RS232 RS485	C2 C4
Enclosure:	No Voltage Boost Voltage Boost	NB VB
Optional Approvals:	Explosion Proof (CID1)	EXP

Dimensions

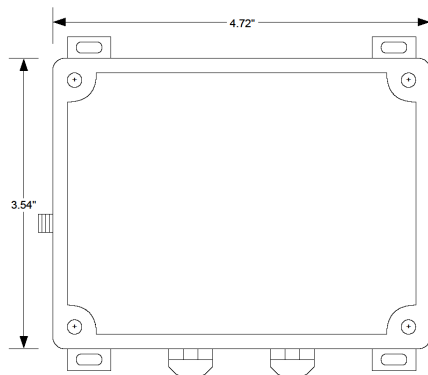

Model:	ABM	- - -	-	CG	- -	-	- -	-	- - -
---------------	-----	-------	---	----	-----	---	-----	---	-------

Remote Dry Contact Monitor



The Remote Dry Contact Monitor (RDCM) is designed to monitor a single dry relay or switch contact and reports its status to the ABM Sensor Access server. Users can login to the ABM Sensor Access server to configure their monitor, view alarm history and setup emails to receive alarm messages.

Features

- Remote monitoring for single dry relay or switch contact
- Wireless communication via cellular network
- Web-based ABM Sensor Access portal for monitoring, configuration and alarm via email message setup
- NEMA 4 / 4X enclosure, suitable for outdoor installation

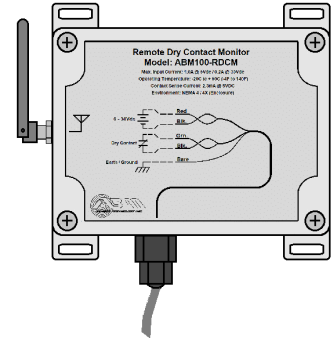

Technical Data	
Supply Voltage:	12-30 VDC Power
Input:	Single dry relay or switch contact
Current:	2.3 mA @ 5 VDC
Output:	Cellular data transmission to ABM servers
Configuration:	Remote via Sensor Access website
Temperature:	-40 to 60°C (-40 to 140°F)
Antenna:	Detached magnetic base antenna or side mounted antenna
Enclosure:	NEMA 4 / 4X, wall mountable

Dimensions

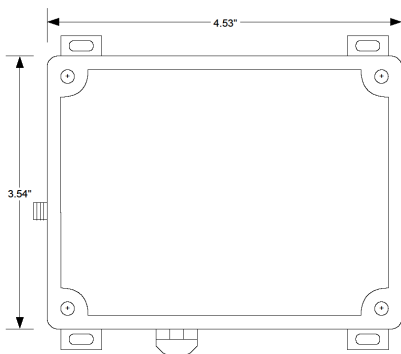

Model:	ABM	100	-	RDCM
---------------	-----	-----	---	------

[Table of Contents >](#)

Order from: **C A Briggs Company**; 622 Mary Street; Suite 101 - Warminster, PA 18974
 Phone: 267-673-8117 - Fax: 267-673-8118; E-Mail: Sales@cabriggs.com - www.cabriggs.com

Relay Controller



The Relay Controller provides a simple and low cost means of monitoring ABM's radar and ultrasonic level sensors and controlling pumps and alarms according to the level measured.

Features

- Pump control and alarms applications
- Connects with ABM level sensors via 4-20 mA output
- Wall mountable for convenient measurement readout
- Three (3) or six (6) relay options
- Simple push-button programming
- Ingress protection IP66 rating (NEMA 4X)



Technical Data	
Display:	LCD display and LED indicators (3 or 6)
Display Units:	Percentage (%)
Display Range:	100% @ 20 mA, 0% @ 4 mA
Input:	One (1) sensor with 4-20 mA output
Relays:	<p>Three (3) Relays: 2 relays each with a form A normally open contact. 1 relay with a form C contact.</p> <p>Six (6) Relays: 4 relays each with a form A normally open contact. 2 relays with a form C contact.</p>
Contact Rating:	8A at 240 VAC non-inductive
Configuration:	Three (3) push-buttons for programming
Temperature:	-20 to 50°C (-5 to 122°F)
Humidity:	0 - 95% non-condensing
Current:	0 to 25 mA (max. overload 70 mA)
Enclosure:	NEMA 4X / IP66, wall mountable

Catalogue Number Ordering		
Supply Voltage:	12-30 VDC Power (3-wire) 115 VAC Power (4-wire) 230 VAC Power (4-wire)	300 400 430
Relays:	Three (3) Six (6)	3 6
Product:	Relay Controller	RCON

Dimensions

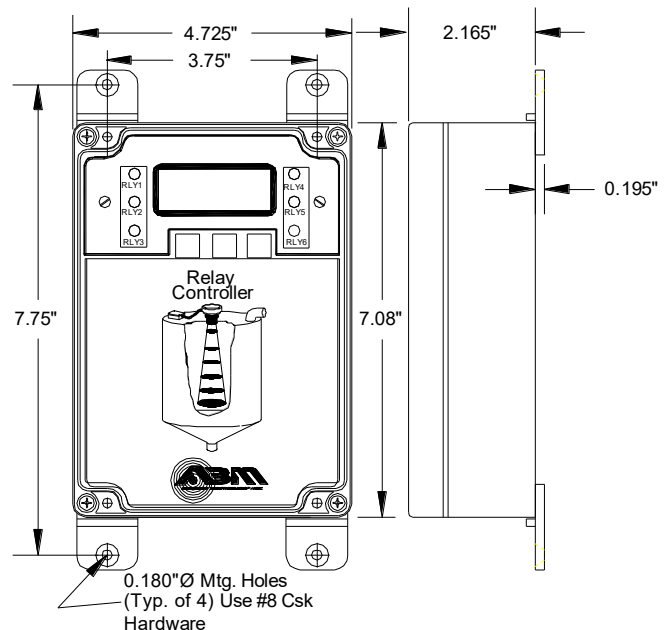

Model:	ABM	-	-	-	RCON
---------------	-----	---	---	---	------

Wall Mount Loop-Powered Display



The Wall Mount loop-powered display can be installed in any location for convenient readout of the current level measurement from an ABM ultrasonic or radar level sensor.

Features

- Level data display (% , meters, feet, gallons, liters)
- Connects with ABM level sensors via 4-20 mA output
- Wall mountable for convenient measurement readout
- Three (3) digit LCD display
- Ingress protection IP65 rating (NEMA 4X)



Technical Data	
Display:	3 digit LCD 1/2" (12.7 mm) high
Display Units:	Percentage (%), meters (m), feet (ft) or user defined
Display Range:	Normal mode 100% @ 20 mA and 0% @ 4 mA Reverse model 100% @ 4 mA and 0% @ 20 mA 22 mA and above = LOE (Loss of Echo)
Accuracy:	Reading +/- 0.5%
Range:	3.5 mA to 22 mA
Maximum Current:	150 mA
Voltage Drop:	0.95V @ 20 mA
Temperature:	-40 to 60°C (-40 to 140°F)
Humidity:	0 - 95% non-condensing
Enclosure:	NEMA 4X / IP65, wall mountable

Dimensions

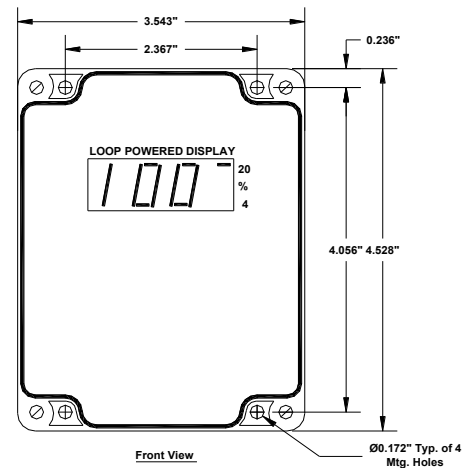

Model:	LPD	-	WM	-	02
---------------	-----	---	----	---	----

Sensor Mount Loop-Powered Display



The Sensor Mount loop-powered display is conveniently installed on the top of the sensor for display of the current level measurement from an ABM ultrasonic or radar level sensor.

Features

- Level data display (% , meters, feet, gallons, liters)
- Connects with ABM level sensors via 4-20 mA output
- Sensor mount for convenient measurement readout
- 4 1/2 digit LCD display
- Ingress protection IP65 rating (NEMA 4X)



Technical Data	
Display:	4 1/2 digit LCD 1/2" (12.7 mm) high
Display Units:	Percentage (%), meters (m), feet (ft) or user defined
Display Range:	Normal mode 100% @ 20 mA and 0% @ 4 mA Reverse model 100% @ 4 mA and 0% @ 20 mA 22 mA and above = LOE (Loss of Echo)
Accuracy:	Reading +/- 0.5%
Range:	3.5 mA to 22 mA
Maximum Current:	150 mA
Voltage Drop:	0.95V @ 20 mA
Temperature:	-40 to 60°C (-40 to 140°F)
Humidity:	0 - 95% non-condensing
Enclosure:	NEMA 4X, IP65

Dimensions

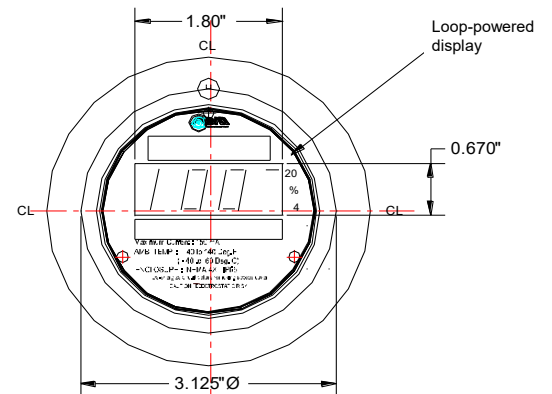

Model:	LPD	-	PM	-	02
---------------	-----	---	----	---	----

Mounting Accessories

Aimers are used for positioning non-contact level sensors for optimal performance. Ideal for bulk solids, the aimers make it simple to point a sensor toward the tank / silo discharge hole.



Outside Tank Mount Aimer

- Simple alignment with swivel ball
- For tanks up to 40 ft with short or no standpipes
- 8" or 9" O.D. flange with 3" NPT for sensor mounting

Model: AIM3-OM



Inside Tank Mount Aimer

- Used to bypass standpipes or shield a sensor from RF interference
- Simple alignment with joystick swivel ball
- 8" or 9" O.D. flange with 1" NPT for sensor mounting

Model: AIM3-IM

Mounting bracket for radar level sensors installed in manholes.



Radar Manhole Mounting Bracket

- Aluminum mounting bracket with backing plate for simple removal
- Sliding mounting adapter for easy alignment over water channel
- 2" NPT for sensor mounting

Model: SMMB-AL

Antenna extensions for stand pipes ensure the radar level sensors Teflon rod antenna exceeds the mounting and sits inside the tank.



Radar Antenna Extension

- Extension for stand pipe mounting
- SS316L sleeve with 1/2" SPT
- 6" or 8" extension length options

Model (6" Extension): AE6 **Model (8" Extension):** AE8

Adapters for mini ultrasonic level transmitters reduce mounting to meet smaller NPT mounting requirements.



Mini Ultrasonic Mounting Adapter

- Adapter to reduce mounting
- PVC adapter threads onto transducer
- 1" NPT to 1/2" NPT adapter or 1" NPT to 3/4" NPT adapter options

Model (1/2" Adapter): A12 **Model (3/4" Adapter):** A34

Approvals

Ultrasonic Approvals	
CE	IEC 61010-1:90 + A1:92 + A2:95
FM (USA)*	FM3810 (2005): Electrical Electronic Test, Measuring and Process Control Equipment
	ANSI/NEMA 250 (1991): Enclosures for Electrical Equipment
FM (CAN)*	CSA C22.2 No. 1010.1 (2004): Safety Requirements for Electrical Equipment for Measurement, Control and Laboratory Use. Part 1: General Requirements
	CSA C22.2 No. 94 (2011): Special Purpose Enclosures
* For sensor models with aluminum or stainless steel enclosures only.	

Radar Approvals	
FCC	Part 15 - Low Power Communication Device. View Certification
FM (USA)	FM3810 (2005): Electrical Electronic Test, Measuring and Process Control Equipment
	ANSI/NEMA 250 (1991): Enclosures for Electrical Equipment
FM (CAN)	CSA C22.2 No. 1010.1 (2004): Safety Requirements for Electrical Equipment for Measurement, Control and Laboratory Use. Part 1: General Requirements
	CSA C22.2 No. 94 (2011): Special Purpose Enclosures

Radar Explosion Proof Approvals	
FM & CSA (US & CAN)	Explosion Proof For Class I, Div.1, Groups B, C, D
	Dust-Ignition Proof Enclosure for Class II / III Div. 1, Groups E, F, G
	Certificate of Compliance (USA) Certificate of Compliance (Canada)

Contact

Order from: **C A Briggs Company**
 622 Mary Street; Suite 101; Warminster, PA 18974
 Phone: 267-673-8117 - Fax: 267-673-8118
Sales@cabriggs.com - www.cabriggs.com



For more information please Contact:
The C A Briggs Company

Technical data subject to change without notice.