

PROVU PD6300 Pulse Input Rate/Totalizer Instruction Manual



PROVU[®]
SERIES



Rate/Totalizer

- Pulse, Open Collector, NPN, PNP, TTL, Switch Contact, Sine Wave (Coil), Square Wave Inputs
- 5, 10, or 24 V Flowmeter Power Supply
- Displays Rate and Total Simultaneously
- Count Up or Down, Total & Grand Total
- Gate Function for Rate Display of Slow Pulse Rates
- K-Factor, Internal Scaling, or External Calibration
- Non-Resettable Grand Total
- Dual-Line Display
- NEMA 4X and IP65 Rated Front Panel
- UL Listed & CE Marked
- Display Features 0.6" & 0.46" Digits
- Six Full Digits on Each Line
- Optional Superluminous Sunlight Readable Display
- Free USB Programming Software & Cable
- 2 or 4 Relays + Isolated 4-20 mA Output Options
- USB, RS-232, & RS-485 Serial Communication Options
- External 4-Relay & Digital I/O Expansion Modules
- Input Power Options Include 85-265 VAC or 12-24 VDC
- Isolated 24 VDC @ 200 mA Transmitter Power Supply
- Modbus[®] RTU Communication Protocol Standard

Order from:

C A Briggs Company

622 Mary Street; Suite 101
Warminster, PA 18974



Phone: 267-673-8117 - Fax: 267-673-8118
Sales@cabriggs.com - www.cabriggs.com

**PRECISION
DIGITAL**

www.predig.com

Disclaimer

The information contained in this document is subject to change without notice. Precision Digital makes no representations or warranties with respect to the contents hereof; and specifically disclaims any implied warranties of merchantability or fitness for a particular purpose.

 CAUTION: <i>Read complete instructions prior to installation and operation of the meter.</i>	 WARNING: <i>Risk of electric shock or personal injury.</i>
--	--

 WARNING: <i>This product is not recommended for life support applications or applications where malfunctioning could result in personal injury or property loss. Anyone using this product for such applications does so at his/her own risk. Precision Digital Corporation shall not be held liable for damages resulting from such improper use.</i>

Limited Warranty

Precision Digital Corporation warrants this product against defects in material or workmanship for the specified period under “Specifications” from the date of shipment from the factory. Precision Digital’s liability under this limited warranty shall not exceed the purchase value, repair, or replacement of the defective unit.

Registered Trademarks

PROVU® and MeterView® Pro are registered trademarks of Precision Digital Corporation. Modbus® is a Registered Trademark of Schneider Automation Inc. All other trademarks mentioned in this document are the property of their respective owners.

© 2017 Precision Digital Corporation. All rights reserved.

www.predig.com

Table of Contents

Table of Contents	3
Table of Figures	4
Introduction	4
Ordering Information	5
Specifications	6
General	6
Rate Input	6
Rate/Totalizer	7
Relays	7
Isolated 4-20 mA Transmitter Output	8
Modbus® RTU Serial Communications	8
PDA1044 Digital Input & Output Expansion Module	8
MeterView Pro	8
Compliance Information	9
Safety	9
Electromagnetic Compatibility	9
Safety Information	10
Installation	10
Unpacking	10
Panel Mounting Instructions	10
Mounting Dimensions	11
Transmitter Supply Voltage Selection (P+, P-)	11
Connections	12
Connectors Labeling	12
Power Connections	12
Signal Connections	13
Modbus RTU Serial Communications	13
Relay Connections	13
Switching Inductive Loads	14
F4 Digital Input Connections	14
4-20 mA Output Connections	15
Analog Output Transmitter Power Supply	15
External Relay & Digital I/O Connections	15
Interlock Relay Feature	16
Setup and Programming	17
Front Panel Buttons and Status LED Indicators	17
MeterView® Pro Software	18
MeterView Pro Installation	18
Display Functions and Messages	19
Main Menu	21
Setting Numeric Values	21
Setting Up the Rate/Totalizer Meter (SEtUP)	22
Setting the Input Signal (<i>inPUt</i>)	22
Setting the Totalizer Features (<i>taTAL</i>)	22
Setting the Input Units or Custom Tags (<i>unITS</i>)	23
Setting the Decimal Point (<i>dEc Pt</i>)	23
Programming the Rate/Totalizer (<i>PrGr</i>)	24
K-Factor Calibration (<i>FRctOr</i>)	24
Multi-Point Calibration & Scaling	24
Scaling the Meter (<i>ScALe</i>)	25
Gate Function (<i>GRtE</i>)	26
Contact De-Bounce Filter (<i>FiltEr</i>)	26
Time Base, Total Conversion Factor & Total Reset	27
Calibrating the Meter with External Source (<i>LRl</i>)	27
Setting the Display Parameter & Intensity (<i>dSPLY</i>)	28
Setting the Relay Operation (<i>rELAY</i>)	29
Relay Assignment (<i>R55 in</i>)	30
Setting the Relay Action	30
Programming Set and Reset Points	30
Setting Fail-Safe Operation	30
Programming Time Delay	30
Relay and Alarm Operation Diagrams	31
High Alarm Operation (Set > Reset)	31
Low Alarm Operation (Set < Reset)	31
High Alarm with Fail-Safe Operation (Set > Reset)	31
Low Alarm with Fail-Safe Operation (Set < Reset)	31
Pump Alternation Control Operation	32
Rate Relay Sampling Operation	32
Total Relay Sampling Operation	32
Time Delay Operation	33
Relay Operation Details	34
Overview	34
Relays Auto Initialization	34
Fail-Safe Operation	34
Front Panel LEDs	34
Latching and Non-Latching Relay Operation	35
Non-Latching Relay (<i>RuLo</i>)	35
Non-Latching Relay (<i>R-nnRn</i>)	35
Latching Relay (<i>LRtCH</i>)	35
Latching Relay (<i>Lt-Lr</i>)	35
Acknowledging Relays	36
Setting Up the Interlock Relay (Force On) Feature	36
Interlock Relay Operation Example	37
Scaling the 4-20 mA Analog Output (<i>Rout</i>)	37
Reset Menu (<i>rESEt</i>)	37
Control Menu (<i>CoNtRl</i>)	37
Setting Up the Password (<i>PR55</i>)	38
Protecting or Locking the Meter	38
Total Reset Password & Non-Resettable Total	38
Making Changes to a Password Protected Meter	39
Disabling Password Protection	39
Advanced Features Menu	40
Advanced Features Menu & Display Messages	40
Rounding Feature (<i>rouNd</i>)	41
Modbus RTU Serial Communications (<i>5Er RL</i>)	41
Select Menu (<i>SELEct</i>)	42
Signal Input Conditioning (<i>FunctiOn</i>)	42
Multi-Point Linearization (<i>LiNEAr</i>)	42
Low-Flow Cutoff (<i>CuTOff</i>)	42
Analog Output Programming (<i>RoutPr</i>)	42
Programmable Function Keys User Menu (<i>u5Er</i>)	43
Meter Operation	45
Front Panel Buttons Operation	45
Function Keys Operation	45
F4 Operation	45
Maximum/Minimum Readings	46
Troubleshooting	47
Diagnostics Menu (<i>d iAG</i>)	47
Determining Software Version	47

Reset Meter to Factory Defaults -----	47	Troubleshooting Tips -----	50
Factory Defaults & User Settings-----	48	EU Declaration of Conformity-----	51

Table of Figures

Figure 1: 1/8 DIN Panel Cutout and Mounting	10	Figure 12: Switch Input Connections.....	13
Figure 2: Meter Dimensions - Side View	11	Figure 13: Relay Connections	13
Figure 3: Meter Dimensions - Top View	11	Figure 14: AC and DC Loads Protection.....	14
Figure 4: Transmitter Supply Voltage Selection.....	11	Figure 15: Low Voltage DC Loads Protection	14
Figure 5: Connector Labeling for Fully Loaded PD6300	12	Figure 16: F4 Digital Input Connections	14
Figure 6: Power Connections.....	12	Figure 17: 4-20 mA Output Connections	15
Figure 7: Flowmeter Powered by Internal Power Supply	13	Figure 18: Expansion Modules & DIN Rail Mounting Kit.....	15
Figure 8: Flowmeter Powered by External Supply ...	13	Figure 19: External Relays Module Connections.....	15
Figure 9: Self-Powered Magnetic Pickup Coil Flowmeter	13	Figure 20: Digital I/O Module Connections.....	15
Figure 10: NPN open Collector Input.....	13	Figure 21: Interlock Connections	16
Figure 11: PNP Sensor Powered by Internal Supply	13	Figure 22: Acknowledge Relays w/Function Key or Digital Input	36

Introduction

The PROVU® PD6300 is a multipurpose, easy to use pulse rate/totalizer ideal for flow rate, total, and control applications. Its superluminous LED digits make it easily readable in smoke, dust, fog, and, with the optional SunBright® display, even direct sunlight. It accepts pulse (40 mVp-p to 8 Vp-p), square wave (0-5 V, 0-12 V, or 0-24 V), open collector, NPN, PNP, TTL or switch contact signals. Three of the front panel buttons can be custom-programmed for specific operation.

The basic model includes an isolated 24 VDC transmitter power supply that can be used to power the input transmitter or other devices. An additional isolated 24 VDC power supply is included with the 4-20 mA output option. A digital input is standard.

A fully loaded PD6300 pulse rate/totalizer meter has the following: four SPDT relays, 4-20 mA output, and two 24 VDC power supplies. The PD6300 capabilities may be enhanced by adding the following external expansion modules: four SPST relays (creating an eight-relay rate/totalizer), two digital I/O modules with four inputs and four outputs each, and RS-232, RS-485, and USB communication adapters.

The eight relays can be used for alarm indication or process control applications. The 4-20 mA isolated output, Modbus RTU serial communications, and digital I/O options make the PD6300 an excellent addition to any system.

Ordering Information

Standard Models

85-265 VAC Model	12-24 VDC Model	Options Installed
PD6300-6R0	PD6300-7R0	No options
PD6300-6R2	PD6300-7R2	2 relays (PD1102*)
PD6300-6R3	PD6300-7R3	4-20 mA output (PD1103*)
PD6300-6R4	PD6300-7R4	4 relays (PD1104*)
PD6300-6R5	PD6300-7R5	2 relays & 4-20 mA output (PD1105*)
PD6300-6R7	PD6300-7R7	4 relays & 4-20 mA output (PD1107*)
*Model number for replacement option card.		

SunBright Display Models

85-265 VAC Model	12-24 VDC Model	Options Installed
PD6300-6H0	PD6300-7H0	No options
PD6300-6H2	PD6300-7H2	2 relays (PD1102*)
PD6300-6H3	PD6300-7H3	4-20 mA output (PD1103*)
PD6300-6H4	PD6300-7H4	4 relays (PD1104*)
PD6300-6H5	PD6300-7H5	2 relays & 4-20 mA output (PD1105*)
PD6300-6H7	PD6300-7H7	4 relays & 4-20 mA output (PD1107*)
*Model number for replacement option card.		

Accessories

Model	Description
PDA1002	DIN-Rail mounting kit for two expansion modules
PDA1004	4 SPST (Form A) relays
PDA1044	4 digital inputs & 4 digital outputs (2 may be connected)
PDA1232	RS-232 serial adapter
PDA1485	RS-485 serial adapter
PDA7485-I	RS-232 to RS-422/485 isolated converter
PDA8232-N	USB to RS-232 non-isolated converter
PDA8485-I	USB to RS-422/485 isolated converter
PDA2811	1 Meter Plastic NEMA 4X Enclosure
PDA2812	2 Meter Plastic NEMA 4X Enclosure
PDX6901	Suppressor (snubber): 0.01 μ F/470 Ω , 250 VAC

Specifications

Except where noted all specifications apply to operation at +25°C.

General

Display	Line 1: 0.6" (15 mm) high, red LEDs Line 2: 0.46" (12 mm) high, red LEDs 6 digits: each (-99999 to 999999), with lead zero blanking.
Display Intensity	Eight user selectable intensity levels
Display Update Rate	Rate: 10 per second; up to 1 per 100 seconds (and is a function of Low Gate setting) Total: 10 per second (fixed)
Overrange	Display flashes 999999
Display Assignment	Display lines 1 & 2 may be assigned to rate, total, grand total, alternate rate & total, max/min, units (line 2 only), set points, Modbus input, & more.
Programming Methods	Four front panel buttons, digital inputs, PC and MeterView Pro software, or Modbus registers.
Recalibration	All ranges are calibrated at the factory to read frequency in Hz. No recalibration required.
Max/Min Display	Max/min readings reached by the process are stored until reset by the user or until power to the meter is cycled.
Password	Three programmable passwords restrict modification of programmed settings and two prevent resetting the totals. Pass 1: Allows use of function keys and digital inputs Pass 2: Allows use of function keys, digital inputs and editing set/reset points Pass 3: Restricts all programming, function keys, and digital inputs. Total: Prevents resetting the total manually Gtotal: Prevents resetting the grand total manually
Non-Volatile Memory	All programmed settings are stored in non-volatile memory for a minimum of ten years if power is lost.
Power Options	85-265 VAC 50/60 Hz, 90-265 VDC, 20 W max or 12-24 VDC ± 10%, 15 W max Powered over USB for configuration only
Fuse	Required external fuse: UL Recognized, 5 A max, slow blow; up to 6 meters may share one 5 A fuse
Isolated Transmitter Power Supply	Terminals P+ & P-: 24 VDC ± 10%. 12-24 VDC powered models selectable for 24, 10, or 5 VDC supply (internal jumper J4). 85-265 VAC models rated @ 200 mA max, 12-24 VDC powered models rated @ 100 mA max, @ 50 mA max for 5 or 10 VDC supply.
Isolation	4 kV input/output-to-power line 500 V input-to-output or output-to-P+ supply

Overvoltage Category	Installation Overvoltage Category II: Local level with smaller transient overvoltages than Installation Overvoltage Category III.
Environmental	Operating temperature range: -40 to 65°C Storage temperature range: -40 to 85°C Relative humidity: 0 to 90% non-condensing
Connections	Removable screw terminal blocks accept 12 to 22 AWG wire, RJ45 for external relays, digital I/O, and serial communication adapters.
Enclosure	1/8 DIN, high impact plastic, UL 94V-0, color: black
Mounting	1/8 DIN panel cutout required: 3.622" x 1.772" (92 mm x 45 mm) Two panel mounting bracket assemblies are provided.
Tightening Torque	Screw terminal connectors: 5 lb-in (0.56 Nm)
Overall Dimensions	4.68" x 2.45" x 5.64" (119 mm x 62 mm x 143 mm) (W x H x D)
Weight	9.5 oz (269 g)
Warranty	3 years parts & labor

Rate Input

Inputs	Field selectable: Pulse or square wave 0-5 V, 0-12 V, or 0-24 V @ 30 kHz; TTL; open collector 4.7 kΩ pull-up to 5 V @ 30 kHz; NPN or PNP transistor, switch contact 4.7 kΩ pull-up to 5 V @ 40 Hz; Modbus PV (Slave)
Low Voltage Mag Pickup (Isolated)	Sensitivity: 40 mVp-p to 8Vp-p
Minimum Input Frequency	0.001 Hz Minimum frequency is dependent on high gate setting.
Maximum Input Frequency	30,000 Hz (10,000 for low voltage mag pickup)
Input Impedance	Pulse input: Greater than 300 kΩ @ 1 kHz. Open collector/switch input: 4.7 kΩ pull-up to 5 V.
Accuracy	±0.03% of calibrated span ±1 count
Temperature Drift	Rate display is not affected by changes in temperature.
Multi-Point Linearization	2 to 32 points
Low-Flow Cutoff	0-999999 (0 disables cutoff function)
Decimal Point	Up to five decimal places or none: <i>dddddd, dddddd, dddd, ddd, dd, or dddddd</i>
Calibration	May be calibrated using K-factor, internal calibration, or by applying an external calibration signal.

K-Factor	Field programmable K-factor converts input pulses to rate in engineering units. May be programmed from 0.00001 to 999,999 pulses/unit.
Calibration Range	Input 1 signal may be set anywhere in the range of the meter; input 2 signal may be set anywhere above or below input 1 setting. Minimum input span between any two inputs is 10 Hz. An error message will appear if the input 1 and input 2 signals are too close together.
Filter	Programmable contact de-bounce filter: 40 to 999 Hz maximum input frequency allowed with low speed filter.
Time Base	Second, minute, hour, or day
Gate	Low gate: 0.1-99.9 seconds High gate: 2.0-999.9 seconds
F4 Digital Input Contacts	3.3 VDC on contact. Connect normally open contacts across F4 to COM.
F4 Digital Input Logic Levels	Logic High: 3 to 5 VDC Logic Low: 0 to 1.25 VDC

Rate/Totalizer

Display Assignment	Display lines 1 & 2 may be assigned to rate, total, grand total, alternate rate/total, alternate rate/grand total, set points, alternate rate/units, alternate total/units, alternate grand total/units, display Hi, display Lo, display Hi/Lo, display modbus, display units (line 2) and display off (line 2).
Rate Display Indication	-99999 to 999999, lead zero blanking. "R" LED illuminates while displaying rate or frequency.
Total Display & Total Overflow	0 to 999,999; automatic lead zero blanking. "T" LED is illuminated while displaying total or grand total. Up to 999,999,999 with total-overflow feature. "OF" is displayed to the left of total overflow and ▲ LED is illuminated.
Alternating Display	Either display may be programmed to alternate between rate and total or rate and grand total every 10 seconds.
Total Decimal Point	Up to five decimal places or none: d.dddd, d.ddddd, d.d, or d.dddd Total decimal point is independent of rate decimal point.
Totalizer	Calculates total based on rate and field programmable multiplier to display total in engineering units. Time base must be selected according to the time units in which the rate is displayed.
Totalizer Rollover	Totalizer rolls over when display exceeds 999,999,999. Relay status reflects display.
Total Overflow Override	Program total reset for automatic with 0.1 second delay and set point 1 for 999,999
Totalizer Presets	Up to eight, user selectable under setup menu. Any set point can be assigned to total and may be programmed anywhere in the range of the meter for total alarm indication.

Programmable Delay On Release	0.1 and 999.9 seconds; applied to the first relay assigned to total or grand total. If the meter is programmed to reset total to zero automatically when the preset is reached, then a delay will occur before the total is reset.
Total Reset	Via front panel button, external contact closure on digital inputs, automatically via user selectable preset value and time delay, or through serial communications.
Total Reset Password	Total and grand total passwords may be entered to prevent resetting the total or grand total from the front panel.
Non-Resetable Total	The grand total can be programmed as a non-resetable total by entering the password "050873".  <i>Once the Grand Total has been programmed as "non-resetable" the feature cannot be disabled.</i>

Relays

Rating	2 or 4 SPDT (Form C) internal and/or 4 SPST (Form A) external; rated 3 A @ 30 VDC and 125/250 VAC resistive load; 1/14 HP (≈ 50 W) @ 125/250 VAC for inductive loads
Noise Suppression	Noise suppression is recommended for each relay contact switching inductive loads; see page 14 for details.
Relay Assignment	Relays may be assigned to rate, total, or grand total.
Deadband	0-100% of span, user programmable
High Or Low Alarm	User may program any alarm for high or low trip point. Unused alarm LEDs and relays may be disabled (turn off).
Relay Operation	Automatic (non-latching) Latching (requires manual acknowledge) Sampling (based on time) Alternation control (2 to 8 relays) Off (disable unused relays and enable Interlock feature) Manual on/off control mode
Relay Reset	User selectable via front panel buttons, digital inputs, or PC <ol style="list-style-type: none"> 1. Automatic reset only (non-latching), when the input passes the reset point or total is reset to zero. 2. Automatic + manual reset at any time (non-latching) 3. Manual reset only, at any time (latching) 4. Manual reset only after alarm condition has cleared (Latching with clear) <p><i>Note: Front panel button or digital input may be assigned to acknowledge relays programmed for manual reset.</i></p>
Time Delay	0 to 999.9 seconds, on & off relay time delays Programmable and independent for each relay.

Fail-Safe Operation	Programmable and independent for each relay. <i>Note: Relay coil is energized in non-alarm condition. In case of power failure, relay will go to alarm state.</i>
Auto Initialization	When power is applied to the meter, relays will reflect the state of the input to the meter.

Isolated 4-20 mA Transmitter Output

Output Source	Rate/process, total, grand total, max, min, set points 1-8, Modbus input or manual control mode		
Scaling Range	1.000 to 23.000 mA for any display range.		
Calibration	Factory calibrated: 0.0 to 1000.0 = 4-20 mA output		
Analog Out Programming	23.000 mA maximum for all parameters: Overrange, underrange, max, min, and break		
Accuracy	± 0.1% FS ± 0.004 mA		
Temperature Drift	0.4 µA/°C max from 0 to 65°C ambient, 0.8 µA/°C max from -40 to 0°C ambient <i>Note: Analog output drift is separate from input drift.</i>		
Isolated Transmitter Power Supply	Terminals I+ & R: 24 VDC ± 10%. May be used to power the 4-20 mA output or other devices. Refer to Figure 6 on page 12 and Figure 15 on page 15. All models rated @ 40 mA max.		
External Loop Power Supply	35 VDC maximum		
Output Loop Resistance	Power supply	Minimum	Maximum
	24 VDC	10 Ω	700 Ω
	35 VDC (external)	100 Ω	1200 Ω

Modbus® RTU Serial Communications

Slave Id	1 – 247 (Meter address)
Baud Rate	300 - 19,200 bps

Transmit Time Delay	Programmable between 0 and 199 ms
Data	8 bit (1 start bit, 1 or 2 stop bits)
Parity	Even, Odd, or None with 1 or 2 stop bits
Byte-To-Byte Timeout	0.01 – 2.54 second
Turn Around Delay	Less than 2 ms (fixed)

Note: Refer to the PROVU® Modbus Register Tables located at www.predig.com for details.

PDA1044 Digital Input & Output Expansion Module

Channels	4 digital inputs & 4 digital outputs per module
System	Up to 2 modules for a total of 8 inputs & 8 outputs
Digital Input Logic High	3 to 5 VDC
Digital Input Logic Low	0 to 1.25 VDC
Digital Output Logic High	3.1 to 3.3 VDC
Digital Output Logic Low	0 to 0.4 VDC
Source Current	10 mA maximum output current
Sink Current	1.5 mA minimum input current
+5 V Terminal	To be used as pull-up for digital inputs only. Connect normally open contacts across +5 V & DI 1-4.

MeterView Pro

System Requirements	Microsoft® Windows® XP/Vista/7/8/10
Communications	USB 2.0 (Standard USB A to Micro USB B)
Configuration	Configure meters one at a time

Compliance Information

Safety

UL & c-UL Listed	USA & Canada UL 508 Industrial Control Equipment
UL File Number	E160849
Front Panel	UL Type 4X, NEMA 4X, IP65; panel gasket provided
Low Voltage Directive	EN 61010-1:2010 Safety requirements for measurement, control, and laboratory use

Electromagnetic Compatibility



Emissions	EN 55022:2010 Class A ITE emissions requirements
Radiated Emissions	Class A
AC Mains Conducted Emissions	Class A
Immunity	EN 61326-1:2013 Measurement, control, and laboratory equipment EN 61000-6-2:2005 EMC heavy industrial generic immunity standard
RFI - Amplitude Modulated	80 -1000 MHz 10 V/m 80% AM (1 kHz) 1.4 - 2.0 GHz 3 V/m 80% AM (1 kHz) 2.0 - 2.7 GHz 1 V/m 80% AM (1 kHz)
Electrical Fast Transients	±2kV AC mains, ±1kV other
Electrostatic Discharge	±4kV contact, ±8kV air
RFI - Conducted	10V, 0.15-80 MHz, 1kHz 80% AM
AC Surge	±2kV Common, ±1kV Differential
Surge	1KV (CM)
Power-Frequency Magnetic Field	30 A/m 70%V for 0.5 period
Voltage Dips	40%V for 5 & 50 periods 70%V for 25 periods
Voltage Interruptions	<5%V for 250 periods

Note:

Testing was conducted on PD6300 meters installed through the covers of grounded metal enclosures with cable shields grounded at the point of entry representing installations designed to optimize EMC performance.

Declaration of Conformity available at www.predig.com

Safety Information

 CAUTION: <i>Read complete instructions prior to installation and operation of the meter.</i>	 WARNING: <i>Risk of electric shock or personal injury.</i>
 Warning! <i>Hazardous voltages exist within enclosure. Installation and service should be performed only by trained service personnel.</i>	

Installation

There is no need to remove the meter from its case to complete the installation, wiring, and setup of the meter for most applications. Instructions are provided for changing the transmitter power supply to output 5 or 10 VDC instead of 24 VDC on page 11.

Unpacking

Remove the meter from box. Inspect the packaging and contents for damage. Report damages, if any, to the carrier.

If any part is missing or the meter malfunctions, please contact your supplier or the factory for assistance.

Panel Mounting Instructions

- Prepare a standard 1/8 DIN panel cutout – 3.622" x 1.772" (92 mm x 45 mm). Refer to Figure 1 for more details.
- Clearance: allow at least 6.0" (152 mm) behind the panel for wiring.
- Panel thickness: 0.04" - 0.25" (1.0 mm - 6.4 mm).
Recommended minimum panel thickness to maintain Type 4X rating: 0.06" (1.5 mm) steel panel, 0.16" (4.1 mm) plastic panel.
- Remove the two mounting brackets provided with the meter (back-off the two screws so that there is 1/4" (6.4 mm) or less through the bracket. Slide the bracket toward the front of the case and remove).
- Insert meter into the panel cutout.
- Install mounting brackets and tighten the screws against the panel. To achieve a proper seal, tighten the mounting bracket screws evenly until meter is snug to the panel along its short side. **DO NOT OVER TIGHTEN**, as the rear of the panel may be damaged.

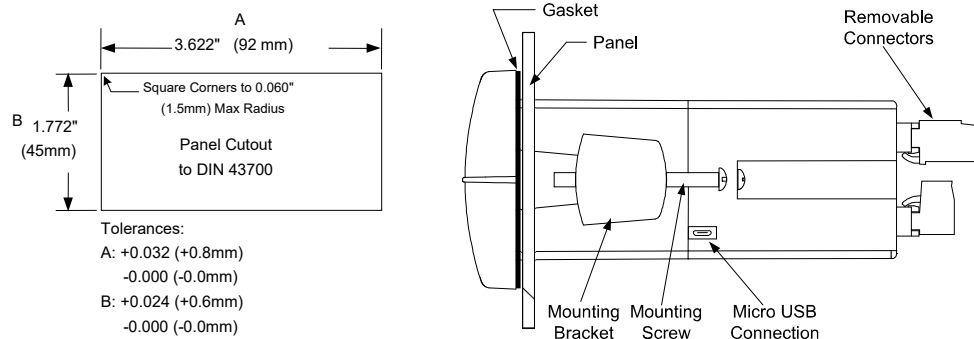

Figure 1: 1/8 DIN Panel Cutout and Mounting

Mounting Dimensions

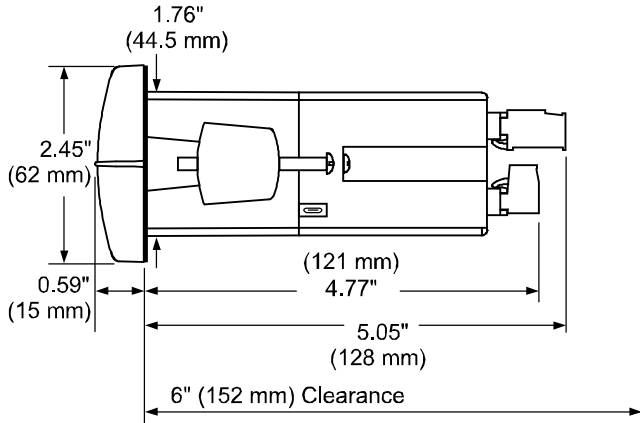

Figure 2: Meter Dimensions - Side View

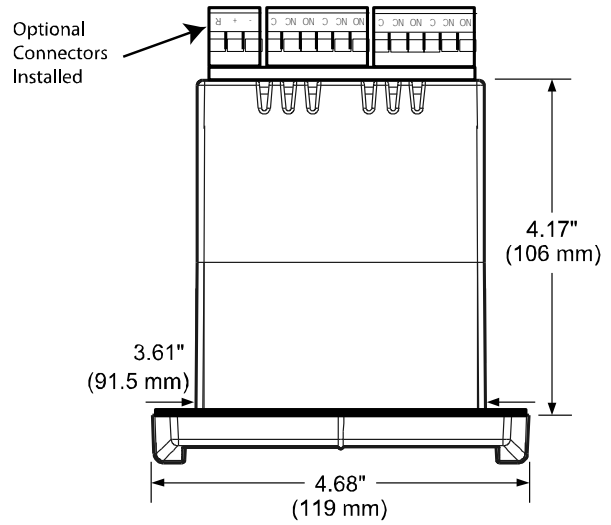

Figure 3: Meter Dimensions - Top View

Transmitter Supply Voltage Selection (P+, P-)

All meters, including models equipped with the 12-24 VDC power option, are shipped from the factory configured to provide 24 VDC power for the transmitter or sensor.

If the transmitter requires 5 or 10 VDC excitation, the internal jumper J4 must be configured accordingly.

To access the voltage selection jumper:

1. Remove all the connectors.
2. Unscrew the back cover.
3. Slide the back cover about 1 inch.
4. Configure the J4 jumper, located behind the input signal connector, for the desired excitation voltage as shown.

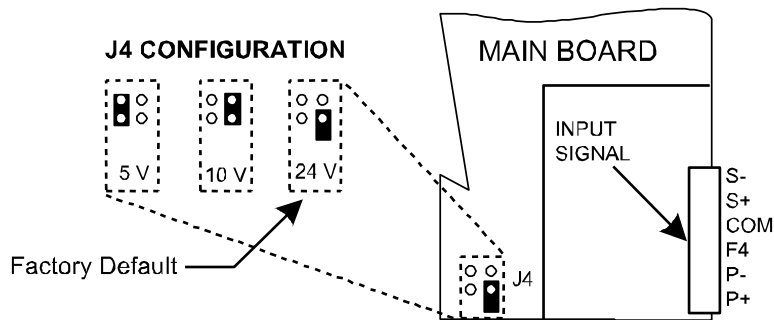



Figure 4: Transmitter Supply Voltage Selection

Connections

All connections are made to removable screw terminal connectors located at the rear of the meter.

 Caution!	<p><i>Use copper wire with 60°C or 60/75°C insulation for all line voltage connections. Observe all safety regulations. Electrical wiring should be performed in accordance with all applicable national, state, and local codes to prevent damage to the meter and ensure personnel safety.</i></p>
--	--

Connectors Labeling

The connectors' label, affixed to the meter, shows the location of all connectors available with requested configuration.

 Warning!	<p>Do not connect any equipment other than Precision Digital's expansion modules, cables, or meters to the RJ45 M-LINK connector. Otherwise damage will occur to the equipment and the meter.</p>
--	--

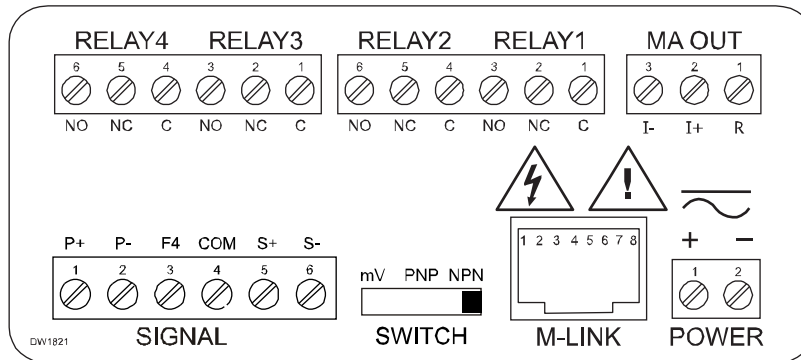
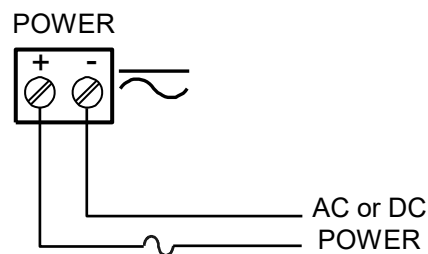

Figure 5: Connector Labeling for Fully Loaded PD6300

Power Connections

Power connections are made to a two-terminal connector labeled POWER on Figure 5. The meter will operate regardless of DC polarity connection. The + and - symbols are only a suggested wiring convention.



Required External Fuse:
5 A max, 250 V Slow Blow

Figure 6: Power Connections

Signal Connections

Signal connections are made to a six-terminal connector labeled SIGNAL on Figure 5. The COM (common) terminal is the return for the input signals.

The following figures show examples of signal connections.

Setup and programming is performed through the front panel buttons.

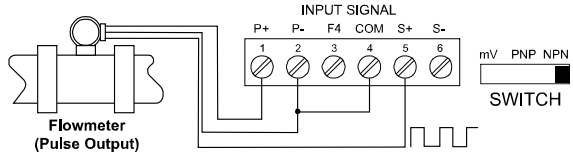

Figure 7: Flowmeter Powered by Internal Power Supply

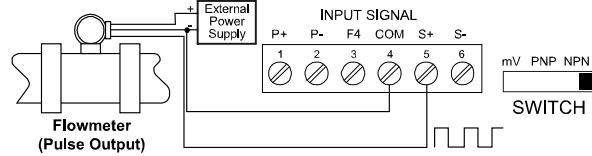

Figure 8: Flowmeter Powered by External Supply

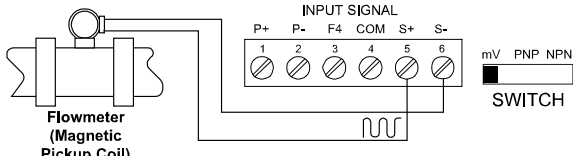

Figure 9: Self-Powered Magnetic Pickup Coil Flowmeter

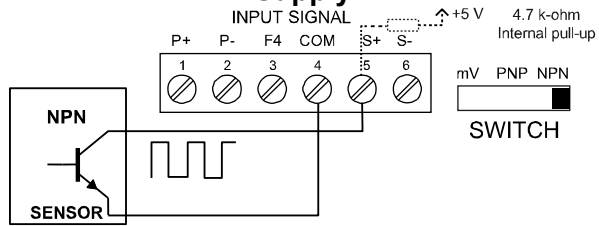

Figure 10: NPN open Collector Input

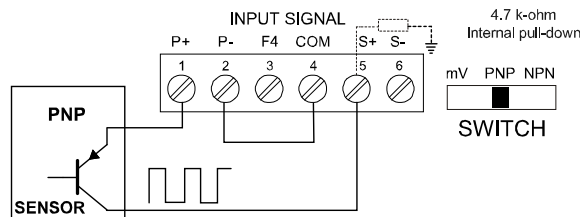

Figure 11: PNP Sensor Powered by Internal Supply

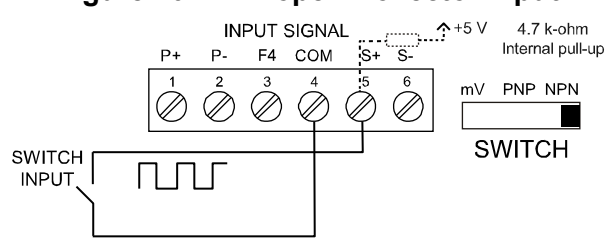

Figure 12: Switch Input Connections

Modbus RTU Serial Communications

Serial communications connection is made to an RJ45 connector labeled M-LINK on Figure 5. For interfacing to the PROVu®, use the PDA1232 for RS-232 or the PDA1485 for RS-485. The same port is used for interfacing with all expansion modules (e.g. external relays, digital I/O).

Relay Connections

Relay connections are made to two six-terminal connectors labeled RELAY1 – RELAY4 on Figure 5. Each relay's C terminal is common only to the normally open (NO) and normally closed (NC) contacts of the corresponding relay. The relays' C terminals should not be confused with the COM (common) terminal of the INPUT SIGNAL connector.

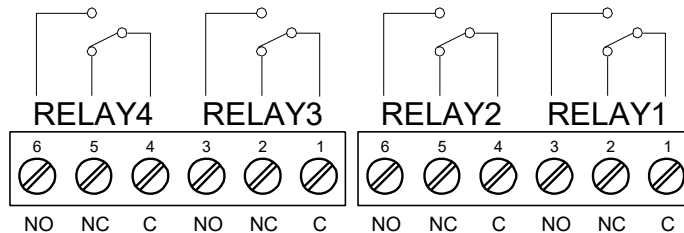

Figure 13: Relay Connections

Switching Inductive Loads

The use of suppressors (snubbers) is strongly recommended when switching inductive loads to prevent disrupting the microprocessor's operation. The suppressors also prolong the life of the relay contacts. Suppression can be obtained with resistor-capacitor (RC) networks assembled by the user or purchased as complete assemblies. Refer to the following circuits for RC network assembly and installation:

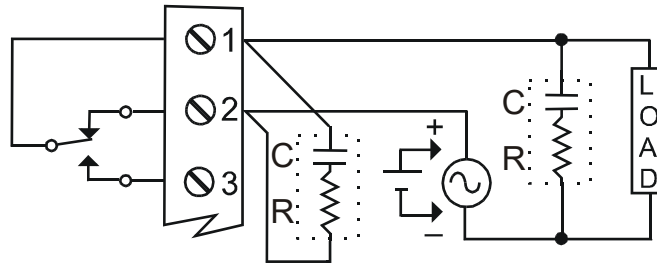

Figure 14: AC and DC Loads Protection

Choose R and C as follows:

R: 0.5 to 1 Ω for each volt across the contacts

C: 0.5 to 1 μF for each amp through closed contacts

Notes:

1. Use capacitors rated for 250 VAC.
2. RC networks may affect load release time of solenoid loads. Check to confirm proper operation.
3. Install the RC network at the meter's relay screw terminals. An RC network may also be installed across the load. Experiment for best results.

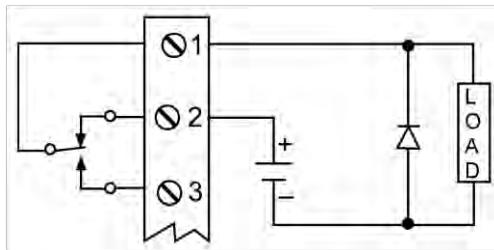

Use a diode with a reverse breakdown voltage two to three times the circuit voltage and forward current at least as large as the load current.

Figure 15: Low Voltage DC Loads Protection

RC Networks Available from Precision Digital

RC networks are available from Precision Digital and should be applied to each relay contact switching an inductive load. Part number: PDX6901.

Note: Relays are de-rated to 1/14th HP (50 watts) with an inductive load.

F4 Digital Input Connections

A digital input, F4, is standard on the meter. This digital input connected with a normally open closure across F4 and COM, or with an active low signal applied to F4.

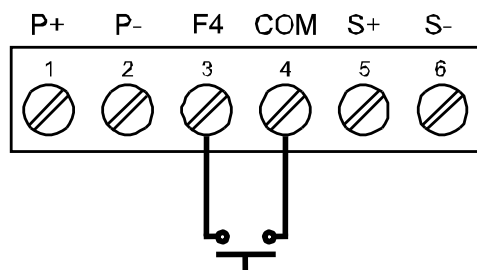

Figure 16. F4 Digital Input Connections

4-20 mA Output Connections

Connections for the 4-20 mA transmitter output are made to the connector terminals labeled MA OUT. The 4-20 mA output may be powered internally or from an external power supply.

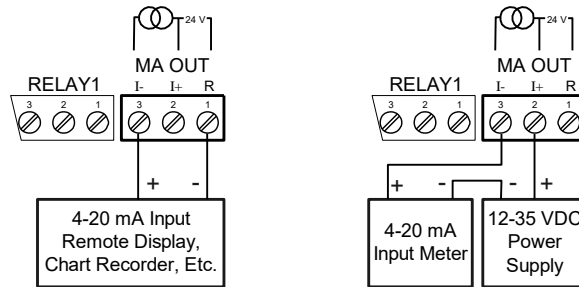

Figure 17: 4-20 mA Output Connections

Analog Output Transmitter Power Supply

The internal 24 VDC power supply powering the analog output may be used to power other devices, if the analog output is not used. The I+ terminal is the +24 V and the R terminal is the return.

External Relay & Digital I/O Connections

The relay and digital I/O expansion modules PDA1004 & PDA1044 are connected to the meter using the CAT5 cable provided with each module. The two RJ45 connectors on the expansion modules are identical and interchangeable; they are used to connect additional modules to the system.

Note: The jumper located between the RJ45 connectors of the PDA1044 must be removed on the second digital I/O module in order for the system to recognize it as module #2.



Warning! Do not connect or disconnect the expansion modules with the power on! More detailed instructions are provided with each optional expansion module.

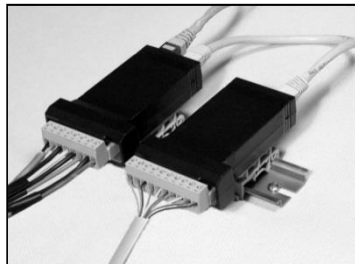

Figure 18: Expansion Modules & DIN Rail Mounting Kit

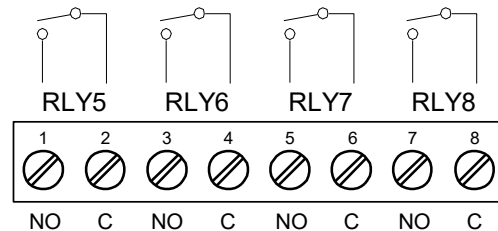

Figure 19: External Relays Module Connections

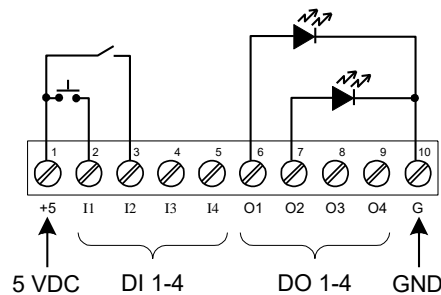

Figure 20: Digital I/O Module Connections

Interlock Relay Feature

As the name implies, the interlock relay feature reassigns one, or more, alarm/control relays for use as interlock relay(s). Interlock contact(s) are wired to digital input(s) and trigger the interlock relay. This feature is enabled by configuring the relay, and relative digital input(s) (see page 36). In one example, dry interlock contacts are connected in series to one digital input which will be used to force on (energize) the assigned interlock power relay when all interlock contacts are closed (safe). The interlock relay front panel LED flashes when locked out. The interlock relay would be wired in-series with the load (N/O contact). See below.

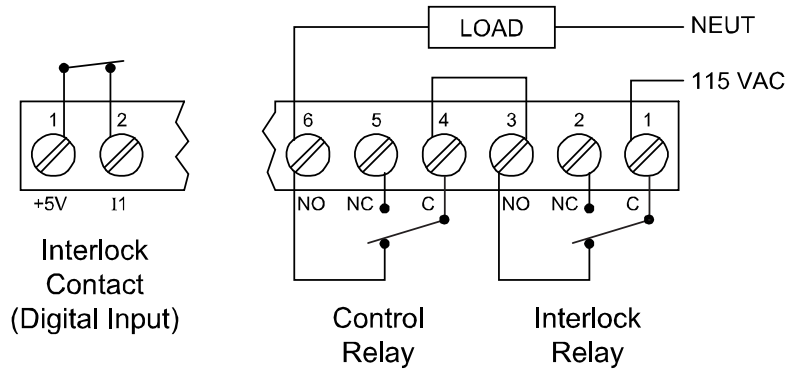

Figure 21: Interlock Connections

Setup and Programming

- The meter has been factory calibrated to read input frequency in Hz (pulses/sec). The calibration equipment is certified to NIST standards.
- Use the *K-Factor* menu to match the rate/totalizer with a flowmeter's k-factor (pulse/unit of measure).
- Or use the *Scale* menu to scale the pulse input (pulse/sec) without a signal source.
- Or use *Cal* menu to calibrate the rate/totalizer using a signal source.
-

Overview

There are two switches, located to the right of the input connector, which must be configured according to the input level and type. Jumper J4 located inside the meter, behind the input signal connector, is used to select the excitation voltage (24 V*, 10 V or 5 V) which is supplied to the P+ and P- wiring terminals.

Setup and programming is done through the front panel buttons.

After power and input signal connections have been completed and verified, apply power to the meter.

**Default setting*

Front Panel Buttons and Status LED Indicators



Button Symbol	Description
	Menu
	Right arrow/F1
	Up arrow/F2
	Enter/F3
<i>Note:</i> F4 is a digital input. Alarms 5-8 are enabled when relay expansion module is installed.	

LED	Status
1-8	Alarm 1 – 8 indicator
R	Rate indicator
T	Total indicator
G T	Grand Total indicator
▲	Total overflow indicator
M	Manual control relays &/or analog output

- Press the Menu button to enter or exit the Programming Mode at any time.
- Press the Right arrow button to move to the next digit during digit or decimal point programming.
- Press or hold the Up arrow button to scroll through the menus, decimal point, or press or hold to increment the value of a digit.
- Press the Enter button to access a menu or to accept a setting.
- Press and hold the Menu button for three seconds to access the advanced features of the meter.

MeterView® Pro Software

The meter can also be programmed using the PC-based MeterView Pro software included with the meter. This software can be installed on any Microsoft® Windows® (XP/Vista/7/8/10) computer by connecting the meter's onboard USB. The meter is powered by the USB connection, so there is no need to wire anything prior to programming the meter, though USB is intended only for meter configuration.

MeterView Pro Installation

1. Connect one end of the provided USB cable to the meter and the other end to the computer. The computer will automatically install the driver software it needs to talk to the meter.

**Only one meter may be connected at a time.
Attaching multiple meters will cause a conflict with the meter software.**

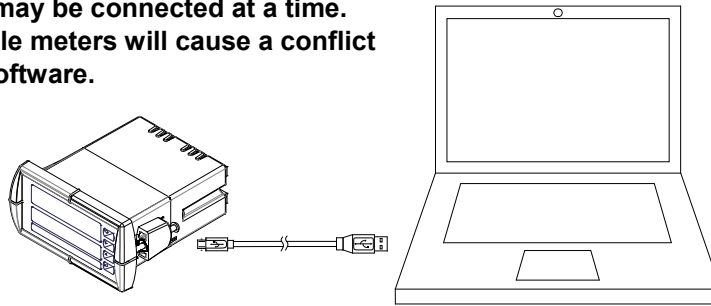

2. Once the driver is installed, an AutoPlay dialog should appear for the drive "MAINSTAL." Click "Open folder to view files." If the computer does not display an AutoPlay dialog for the drive "MAINSTAL," you should open My Computer and double-click on the drive labeled "MAINSTAL."
3. Double-click on the file named "MAStart." The program will open a few windows and install two programs on your computer. Simply follow the onscreen instructions until you see one of the dialogs below. If you receive a "User Account Control" warning, click "Yes."
4. If there is an update available, click the "Update" button to install the new version. Otherwise, click "Configure" to begin programming your meter.

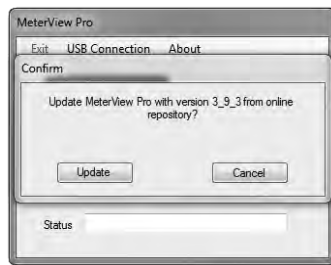
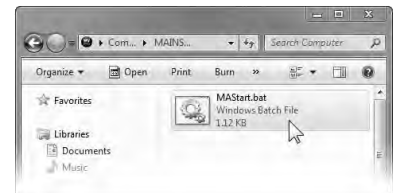

Note: If you decide to update your MeterView Pro software, once the installation has completed, you will be asked if you want to update the setup files located on the meter itself. This way, you will always have the most current version on the meter for future installs.



Do not unplug the meter while the new installation files are being written to it. The meter will display μ ν τ ϵ during the process and you will receive an onscreen notification once the process is complete.

Data logging for one meter at a time is available with MeterView Pro software. More advanced data acquisition may be accomplished by using any Modbus RTU compliant software. Additional information regarding configuration and monitoring of the meter using MeterView Pro software is available online. Go to www.predig.com/meterview-pro.

Display Functions and Messages

The meter displays various functions and messages during setup, programming, and operation. The following table shows the main menu functions and messages in the order they appear in the menu.

Display	Parameter	Action/Setting Description	Display	Parameter	Action/Setting Description
SEtUP	Setup	Enter Setup menu	t CF	Total conversion factor	Program total conversion factor
INPut	Input	Enter Input selection menu	t rSt	Total reset	Program total reset mode: auto or manual
tOtAL	Total	Enable or disable totalizer features	GrT tB	Grand total time base	Program grand total time base
UNtS	Units	Select the display units/tags	GrT CF	Grand total conversion factor	Program grand total conversion factor
rAtE	Rate	Select the display units for rate	GrT rSt	Grand total reset	Program grand total reset mode: auto or manual
tOtAL	Total	Select the display units for total	Auto	Automatic	Press Enter to set automatic total reset
GrTAL	Grand Total	Select the display units for grand total	t dLY	Time delay	Program time delay for total auto reset
dEc Pt	Decimal point	Set decimal point for rate, total, grand total	MAAn	Manual	Press Enter to reset total manually
PrOG	Program	Enter the Program menu	dSPLY	Display	Enter the Display menu
INCAL	Input Calibration	Enter the Input Calibration menu	LnE 1	Line 1	Press Enter to assign the Upper display parameter (default: PV or rate)
FActoR	K-factor Scaling	Programs unit to convert input pulse to rate in engineering units	LnE 2	Line 2	Press Enter to assign the lower display parameter (default: total)
SCALE	Scale	Enter the Scale menu	d-IntY	Display intensity	Set display intensity level from 1 to 8
CAL	Calibrate	Enter the Calibrate menu	rELAY	Relay	Enter the Relay menu
INP 1	Input 1	Calibrate input 1 signal or program input 1 value	R55 n	Assignment	Assign relays to rate, total, grand total, or Modbus
d 1 1	Display 1	Program display 1 value	R5 n 1	Assign 1	Relay 1 assignment
INP 2	Input 2	Calibrate input 2 signal or program input 2 value (up to 32 points)	rAtE	Rate	Assign relay to rate
d 1 2	Display 2	Program display 2 value (up to 32 points)	tOtAL	Total	Assign relay to total
Error	Error	Error, calibration not successful, check signal or programmed value	GrTAL	Grand total	Assign relay to grand total
t tB	Total time base	Program total time base	rLY 1	Relay 1	Relay 1 setup
			Rct 1	Action 1	Set relay 1 action

Display	Parameter	Action/Setting Description
<i>RuLo</i>	<i>Automatic</i>	Set relay for automatic reset
<i>R-man Rn</i>	<i>Auto-manual</i>	Set relay for automatic & manual reset any time
<i>LRLcH</i>	<i>Latching</i>	Set relay for latching operation (relays assigned to rate)
<i>Lc-ELr</i>	<i>Latching-cleared</i>	Set relay for latching operation with manual reset only after alarm condition has cleared (relays assigned to rate)
<i>RLtErn</i>	<i>Alternate</i>	Set relay for alternation control (relays assigned to rate)
<i>SRnnr PL</i>	<i>Sampling</i>	Set relay for sampling operation
<i>OFF</i>	<i>Off</i>	Disable relay and front panel status LED (Select Off to enable Interlock feature)
<i>SEt 1</i>	<i>Set 1</i>	Program set point 1
<i>rSt 1</i>	<i>Reset 1</i>	Program reset point 1
<i>rLY 2</i>	<i>Relay 2</i>	Relays 2-8 setup <i>Note: Relays 5-8 are shown, only if expansion relay module is installed.</i>
<i>FR LSF</i>	<i>Fail-safe</i>	Enter <i>Fail-safe</i> menu
<i>FLS 1</i>	<i>Fail-safe 1</i>	Set relay 1 fail-safe operation
<i>on</i>	<i>On</i>	Enable fail-safe operation
<i>off</i>	<i>Fail-safe off</i>	Disable fail-safe operation
<i>dELAY</i>	<i>Delay</i>	Enter relay <i>Time Delay</i> menu
<i>dLY 1</i>	<i>Delay 1</i>	Enter relay 1 time delay setup
<i>On 1</i>	<i>On</i>	Set relay 1 On time delay
<i>OFF 1</i>	<i>Off</i>	Set relay 1 Off time delay
<i>Rout</i>	<i>Analog output</i>	Enter the <i>Analog output</i> scaling menu

Display	Parameter	Action/Setting Description
<i>d i 1</i>	<i>Display 1</i>	Program display 1 value
<i>Out 1</i>	<i>Output 1</i>	Program output 1 value (e.g. 4.000 mA)
<i>d i 2</i>	<i>Display 2</i>	Program display 2 value
<i>Out 2</i>	<i>Output 2</i>	Program output 2 value (e.g. 20.000 mA)
<i>rESEt</i>	<i>Reset</i>	Press Enter to access the <i>Reset</i> menu
<i>rSt H i</i>	<i>Reset high</i>	Press Enter to reset max display
<i>rSt Lo</i>	<i>Reset low</i>	Press Enter to reset min display
<i>rSt HL</i>	<i>Reset high & low</i>	Press Enter to reset max & min displays
<i>rSt t</i>	<i>Reset total</i>	Press Enter to reset total
<i>rSt Gt</i>	<i>Reset grand total</i>	Press Enter to reset grand total
<i>Control</i>	<i>Control</i>	Enter <i>Control</i> menu
<i>RuLo</i>	<i>Automatic</i>	Press Enter to set meter for automatic operation
<i>man Rn</i>	<i>Manual</i>	Press Enter to manually control relays or analog output operation
<i>PASS</i>	<i>Password</i>	Enter the <i>Password</i> menu
<i>PASS 1*</i>	<i>Password 1*</i>	Set or enter Password 1* (*1, 2, or 3)
<i>total</i>	<i>Total password</i>	Set or enter password for manual reset
<i>Gtotal</i>	<i>Grand total password</i>	Set or enter password for manual reset
<i>nonrSt</i>	<i>Non-resettable</i>	Non-resettable grand total set after entering "050873" for Gtotal password
<i>unLoc</i>	<i>Unlocked</i>	Program password to lock meter
<i>Locd</i>	<i>Locked</i>	Enter password to unlock meter
<i>999999</i>	<i>Flashing display</i>	Overrange condition

Main Menu

The main menu consists of the most commonly used functions: *Reset*, *Control*, *Setup*, and *Password*.

- Press Menu button to enter Programming Mode then press the Up arrow button to scroll through the main menu.
- Press Menu, at any time, to exit and return to Run Mode. Changes made to settings prior to pressing Enter are not saved.
- Changes to the settings are saved to memory only after pressing Enter.
- The display moves to the next menu every time a setting is accepted by pressing Enter.

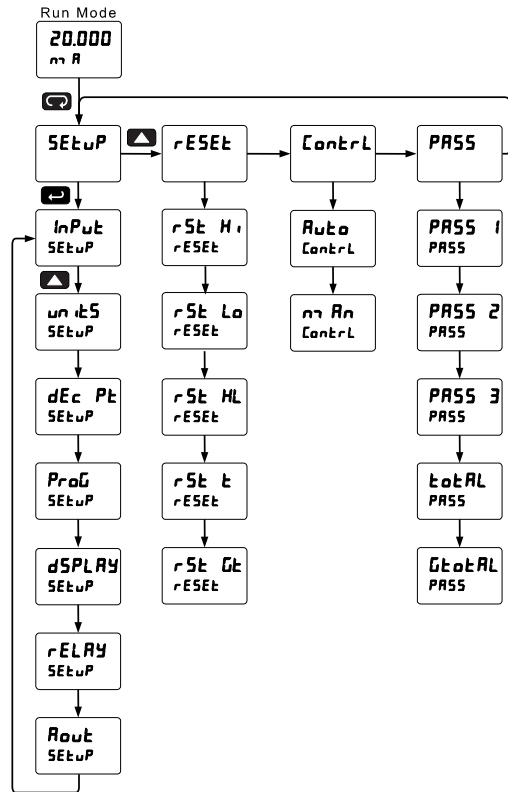

Setting Numeric Values

The numeric values are set using the Right and Up arrow buttons. Press Right arrow to select next digit and Up arrow to increment digit value. The digit being changed is displayed brighter than the rest. Press and hold Up to auto-increment the display value. If negative numbers are allowed, the first digit position will include a negative symbol (-) after the 9.

Press the Enter button, at any time, to accept a setting or Menu button to exit without saving changes.

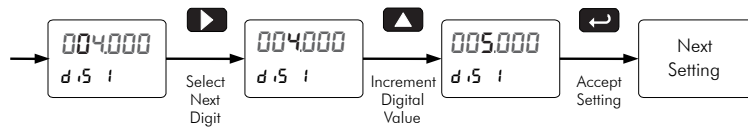

Setting Up the Rate/Totalizer Meter (SEtUP)

The *Setup* menu is used to select:

1. Enable or disable totalizer features
2. Units for Rate, Total, and Grand Total
3. Decimal point position
4. Input Calibration
5. Display parameter and intensity
6. Relay operation
7. 4-20 mA analog output scaling

Press the Enter button to access any menu or press Up arrow button to scroll through choices. Press the Menu button to exit at any time.

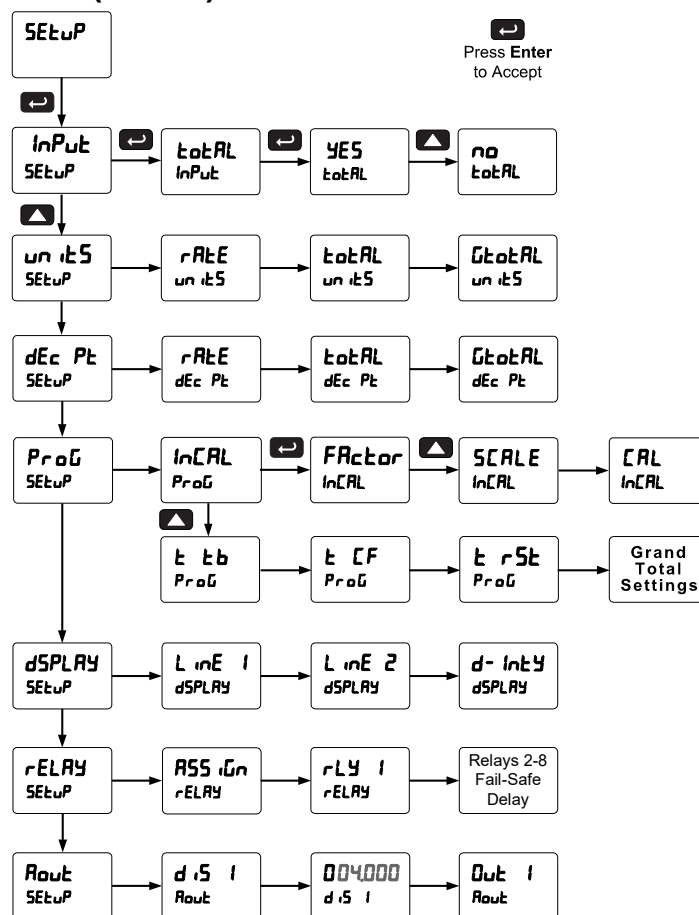

Setting the Input Signal (InPUt)

There is a switch, located to the right of the input connector, which must be configured according to the input level and type. Jumper J4 located inside the meter, behind the input signal connector, is used to select the excitation voltage (24 V [Default setting], 10 V or 5 V) which is supplied to the P+ and P- wiring terminals.

Enter the Input menu to enable or disable the totalizer features.

Setting the Totalizer Features (tOtAL)

Enable or disable the totalizer features by selecting “YES” or “no” after the input type has been set up. If the totalizer features are disabled, most totalizer features and functions are hidden from the menus.

Note: The totalizer continues working in the background.

Setting the Input Units or Custom Tags (u n t5)

Enter the input unit or custom tag that will be displayed if alternating rate, total, or grand total and units is selected in the u n t5 menu, or d u n t is selected as the line 2 parameter. See the flow chart on page 28 to access the display menu to show the unit or tag on line 2. The engineering units or custom legends can be set using the following 7-segment character set:

Display	Character	Display	Character	Display	Character	Display	Character
0	0	C	C	K	K	v	V
1	1	c	c	L	L	v J	w
2	2	d	d	m	m	X	X
3	3	E	E	n	n	Y	Y
4	4	F	F	O	O	Z	Z
5	5	G	G	o	o	-	-
6	6	g	g	P	P	/	/
7	7	H	H	q	q	[]
8	8	h	h	r	r]	[
9	9	I	I	S	S	=	=
A	A	i	i	t	t	°	Degree(<)
b	b	J	J	u	u		Space

Notes:

Degree symbol represented by (<) if programming with MeterView® Pro.

The letters “m” and “w” use two 7-segment LEDs each; when selected the characters to the right are shifted one position.

Press and hold up arrow to auto-scroll the characters in the display.

Setting the Decimal Point (dEc Pt)

The decimal point may be set with up to five decimal places or with no decimal point at all. The rate, total, and grand total decimal points are independent.

Pressing the right arrow moves the decimal point one place to the right until no decimal point is displayed, then it moves to the leftmost position.

Pressing the up arrow moves the decimal point to the left.

Programming the Rate/Totalizer (Prog)

It is **very important** that one reads the following information before programming the meter:

- The meter has been factory calibrated to read input frequency in Hz (pulses/sec). The calibration equipment is certified to NIST standards.
- Use the *K-Factor* menu to match the rate/totalizer with a flowmeter's k-factor (pulse/unit of measure).
- Or use the *Scale* menu to scale the pulse input (pulse/sec) without a signal source.
- Or use *Cal* menu to calibrate the rate/totalizer using a signal source.

The *Program* menu contains the following menus:

1. K-Factor calibration
2. Scale without a signal source
3. Calibrate with a calibrated signal source
4. Total time base & conversion factor
5. Grand total time base & conversion factor
6. Total reset mode for total & grand total

Note: The Scale, Calibrate, and K-Factor functions are exclusive of each other. The meter uses the last function programmed. Only one of these methods can be employed at a time. The Scale and Calibrate functions can use up to 32 points (default is 2). The number of points should be set in the Advanced menu under the Multi-Point Linearization (LINEAR) menu selection prior to scaling and calibration of the meter, see page 42 for details.

The pulse inputs may be calibrated or scaled to any display value within the range of the meter.

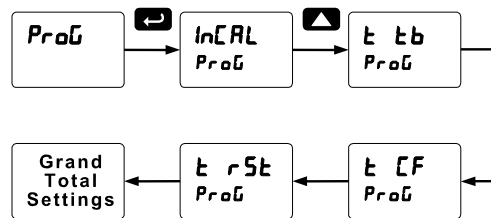

Additional parameters, not needed for most applications, are programmed in the *Advanced Features* menu; see *Advanced Features Menu*, page 40.

K-Factor Calibration (FRactor)

The meter may be calibrated using the *K-Factor* function. Most flowmeter manufacturers provide this information with the device. Enter the *K-Factor* (FRactor) menu and select the decimal point with highest resolution possible and program the k-factor value (i.e. pulses/gal). The meter will automatically calculate the flow rate using the k-factor and the time base selected.



Multi-Point Calibration & Scaling

The meter is set up at the factory for 2-point linear calibration. The number of points for multi-point calibration/scaling is set up in the *Advanced Features* menu. Up to 32 linearization points may be selected. See page 42 for details.

Scaling the Meter (SCALE)

The pulse inputs can be scaled to display the process variable in engineering units.

A signal source is not needed to scale the meter; simply program the inputs and corresponding display values.

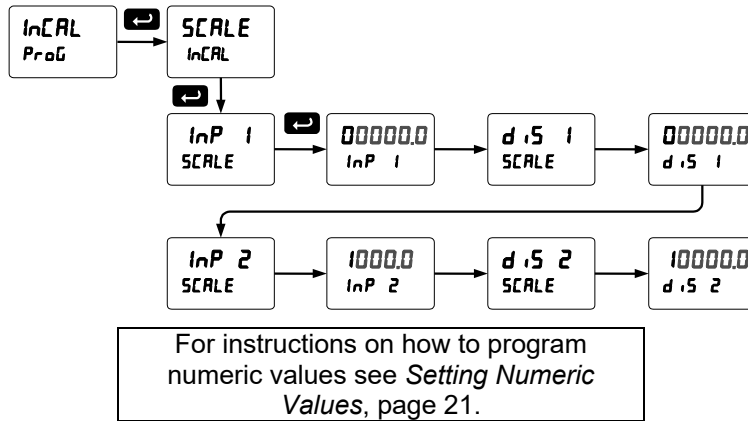

Note: The display values (*d,5 1* and *d,5 2*) need to be in units of measure per second.

For example: If the rate at 1000 Hz is 13.2 gal/min, this must be converted to gal/sec. In this scenario, the numbers input into the *SCALE* menu would be as follows:

```
InP 1: 0.0
d,5 1: 0.000
InP 2: 1000.0
d,5 2: 0.220
```

Set the time base set to minutes (see page 27) and the meter will display 13.2 gal/min at 1000 Hz

Error Message (Error)

An error message indicates that the calibration or scaling process was not successful. After the error message is displayed, the meter reverts to input 2 during calibration or scaling, allowing the appropriate input signal to be applied or programmed.

The error message might be caused by any of the following conditions:

1. Input signal is not connected to the proper terminals or it is connected backwards.
2. Minimum input span requirements not maintained.
3. Input 1 signal inadvertently applied to calibrate input 2.

Minimum Input Span

The minimum allowed input span is 1.0 Hz, which is the minimum difference between input 1 and input 2 signals required to complete the calibration or scaling of the meter.

Gate Function (GATE)

The gate function is used for displaying slow pulse rates. Using the programmable gate, the meter is able to display pulse rates as slow as 1 pulse every 999.9 seconds (0.001 Hz). The gate function can also be used to obtain a steady display reading with a fluctuating input signal.

The gate function (GATE) is the first option in the Advanced Features menu. There are two settings for the GATE, low gate (Lo G) and high gate (Hi G).

Low Gate (Lo G)

For most applications, low gate setting should be left at 1.0 second. Increase low gate setting to obtain a steadier rate display. The rate display will update in accordance with the low gate setting, for example if low gate is set at 10.0, the display will update every 10 seconds; changes in rate between updates will not be reflected until next display update.

High Gate (Hi G)

Set the high gate value to correspond to the highest expected pulse period (lowest pulse rate). For instance, if the meter must display a rate when there is 1 pulse coming into the meter every 10 seconds, set the high gate to 11.0 seconds. When the signal is removed from the meter, the display will show the last reading for 11 seconds; then it will read zero.

Gate Settings

Slow Pulse Rate		
Low Gate* (sec)	High Gate (sec)	Min Freq** (Hz)
1.0	2.0	0.5000
1.0	10.0	0.1000
1.0	20.0	0.0500
1.0	100.0	0.0100
1.0	200.0	0.0050
1.0	400.0	0.0025
1.0	800.0	0.0012
1.0	999.9	0.0010
*The low gate setting corresponds to the display update rate and is used to stabilize the display reading with a fluctuating signal.		
**The minimum frequency is dependent on high gate setting.		

Contact De-Bounce Filter (FILTER)

The filter function (FILTER) can be used for applications where the meter is set up to count pulses generated by switch contacts. The filter value can be set anywhere between 2 and 50, the higher the value, the greater the filtering.

The filter function (FILTER) is the second option in the Advanced Features menu. There are two settings, Hi SPd (high speed) and Lo SPd (low speed), press ENTER when Lo SPd is displayed to enable the filter function. Program the filter value, so that there are no extra counts when a contact closure is completed.

Filter Settings

Contact De-Bounce Filter		
Filter Setting	Speed Setting	Max Freq (Hz)
2	Lo SPd	999
4	Lo SPd	499
8	Lo SPd	249
16	Lo SPd	124
32	Lo SPd	62
40	Lo SPd	50
50	Lo SPd	40
N/A	Hi SPd	30,000

Time Base, Total Conversion Factor & Total Reset

The time base, total conversion factor, and total reset menus are located in the *Program* menu. The total and grand total have their own independent settings. This means that one can be displaying the value in gallons while the other displays in million gallons, liters, m³, etc.

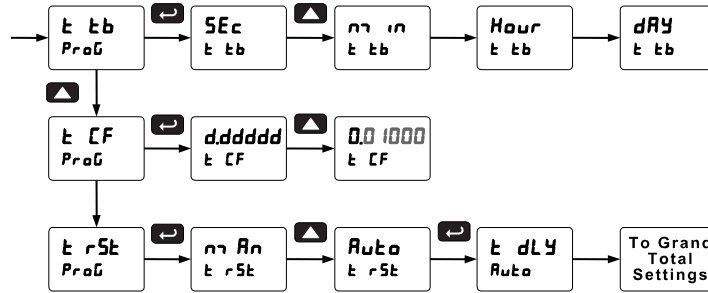

Time Base

The time base is the amount of time over which the rate parameter should accrue. For example, if the rate was ten and the time base was in minutes, then the total would increase by ten every one minute.

Total & Grand Total Conversion Factor

The total & grand total conversion factor is the amount by which the rate is multiplied before it is added to the total or grand total. For Example, if the rate was ten per second and the total conversion factor was 100, the total would increase by 1000 every second. This is useful, for instance, if you want to show rate in gallons and total in thousands of gallons.

Total & Grand Total Reset

The totals can be programmed for manual or automatic reset. In the automatic reset mode, a programmable time delay is available to reset the total or grand total after the assigned preset is reached.

Non-Resettable Totalizer

The total and grand total can be password-protected to prevent unauthorized resets. The grand total can be programmed as a non-resettable total, see page 38 for details.

Calibrating the Meter with External Source (CAL)

To scale the meter without a signal source, refer to K-Factor Calibration on page 24 or Scaling the Meter on page 25

The meter can be calibrated to display the process variable in engineering units by applying the appropriate input signal and following the calibration procedure.

The use of a calibrated signal source is strongly recommended to calibrate the meter.

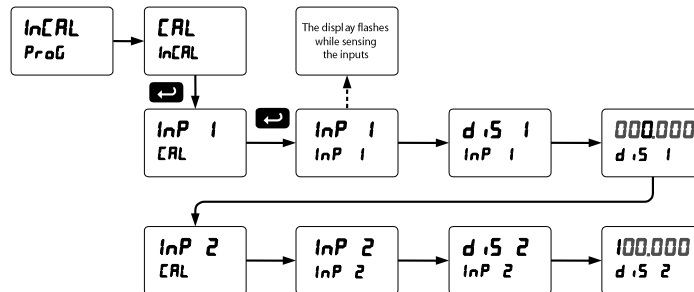

Note: The display values (d .5 1 and d .5 2) need to be in units of measure per second.

There is no need to warm up the meter before performing the calibration procedure.

Setting the Display Parameter & Intensity (dDISPLAY)

Display line 1 (LINE 1) can be programmed to display:

1. Rate value
2. Total or grand total
3. Relay set points
4. Max & min values
5. Modbus input
6. Display rate and units
7. Rate and total
8. Rate and grand total
9. Total and units
10. Grand total and units

Display line 2 (LINE 2) can be programmed to display:

1. Rate value
2. Total or grand total
3. Relay set points
4. Max & min values
5. Engineering units or custom legends
6. Modbus input
7. Off (no display)
8. Display rate and units
9. Rate and total
10. Rate and grand total
11. Total and units
12. Grand total and units

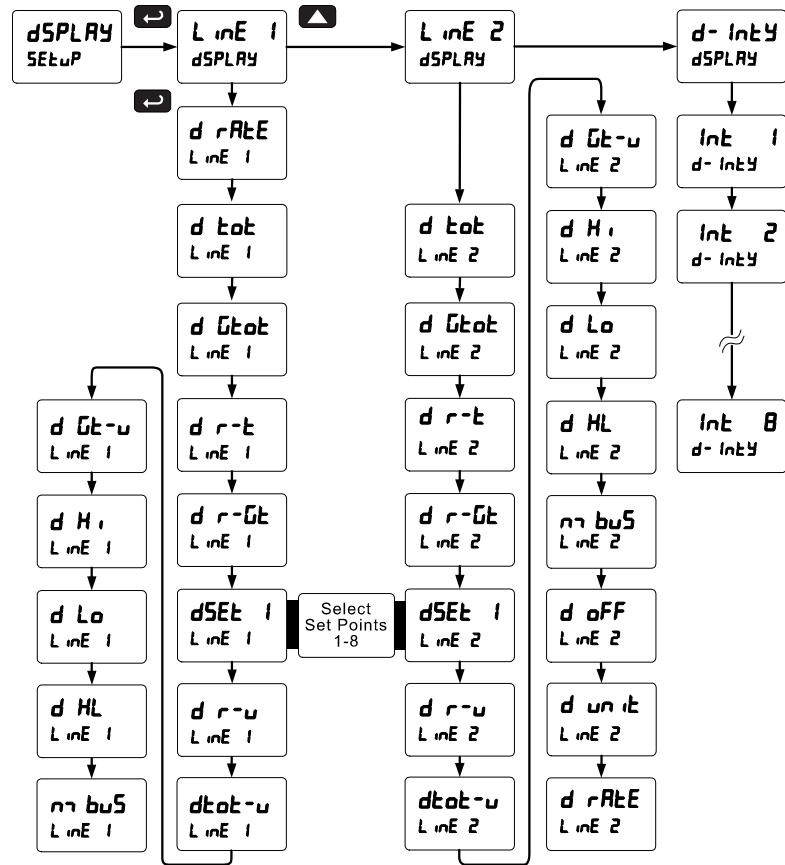

Display Intensity: The meter has eight display intensity levels to give the best performance under various lighting conditions. Select intensity 8 for outdoor applications. The default display intensity setting is 8.

After setting up the input and the display, press the Menu button to exit programming and skip the rest of the setup menu. Press the Menu button again and the Up arrow to reach the *Program* menu and complete the scaling or calibration of the meter.

Setting the Relay Operation (rELAY)

This menu is used to set up the operation of the relays.



Caution! *During setup, the relays do not follow the input and they will remain in the state found prior to entering the Relay menu.*

1. Relay assignment
 - a. Rate for low and high alarm
 - b. Total
 - c. Grand total
 - d. Modbus input
2. Relay action
 - a. Automatic reset only (non-latching)
 - b. Automatic + manual reset at any time (non-latching)
 - c. Latching (manual reset only)
 - d. Latching with Clear (manual reset only after alarm condition has cleared)
 - e. Alternation control (automatic reset only)
 - f. Sampling (the relay is activated for a user-specified time)
 - g. Off (relay state controlled by Interlock feature)
3. Set and reset points
4. Fail-safe operation
 - a. On (enabled)
 - b. Off (disabled)
5. Time delay
 - a. On delay (0-999.9 seconds)
 - b. Off delay (0-999.9 seconds)

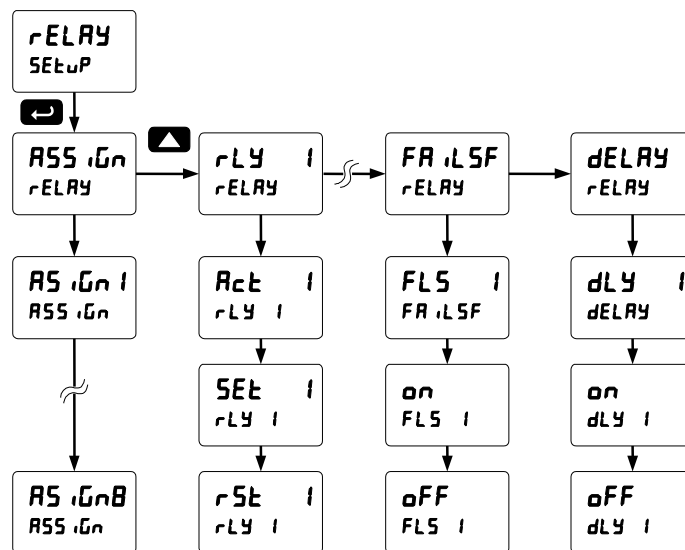

Note: The setup of relays 2-8 follows the same pattern shown here for relay 1.

Relay Assignment (RSS, rLN)

The relays can be assigned to any of the following parameters:

1. Rate for low or high alarm indication
2. Total for alarm indication
3. Grand total for alarm indication
4. Modbus input

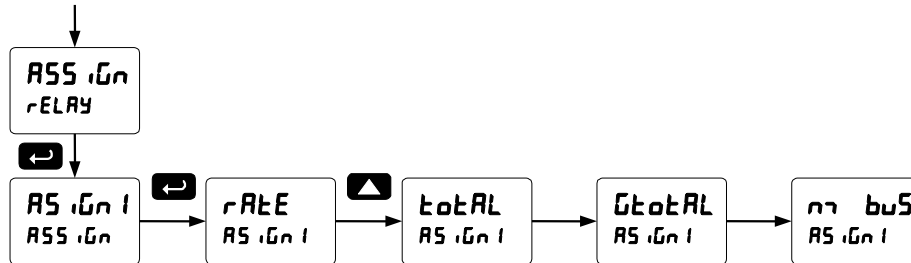

Setting the Relay Action

Operation of the relays is programmed in the *Action* menu. The relays may be set up for any of the following modes of operation:

1. Automatic reset (non-latching)
2. Automatic + manual reset at any time (non-latching)
3. Latching (manual reset only, at any time)
4. Latching with Clear (manual reset only after alarm condition has cleared)
5. Alternation control (automatic reset only)
6. Sampling (the relay is activated for a user-specified time)
7. Off (relay state controlled by Interlock feature)

The following graphic shows relay 1 action setup; relay 2-8 are set up in a similar fashion.

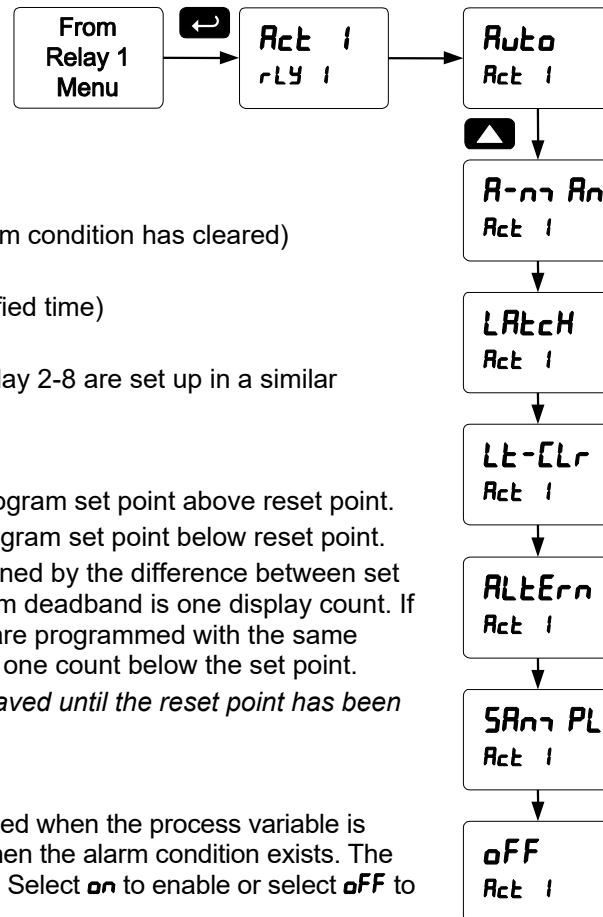

Programming Set and Reset Points

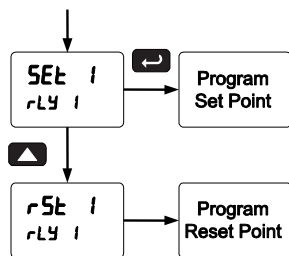

High alarm indication: program set point above reset point.
 Low alarm indication: program set point below reset point.
 The deadband is determined by the difference between set and reset points. Minimum deadband is one display count. If the set and reset points are programmed with the same value, the relay will reset one count below the set point.
Note: Changes are not saved until the reset point has been accepted.

Setting Fail-Safe Operation

In fail-safe mode of operation, the relay coil is energized when the process variable is within safe limits and the relay coil is de-energized when the alarm condition exists. The fail-safe operation is set independently for each relay. Select **on** to enable or select **off** to disable fail-safe operation.

Programming Time Delay

The *On* and *Off* time delays may be programmed for each relay between 0 and 999.9 seconds. The relays will transfer only after the condition has been maintained for the corresponding time delay.

The *On* time delay is associated with the set point.

The *Off* time delay is associated with the reset point.

Relay and Alarm Operation Diagrams

The following graphs illustrate the operation of the relays, status LEDs, and ACK button.

High Alarm Operation (Set > Reset)

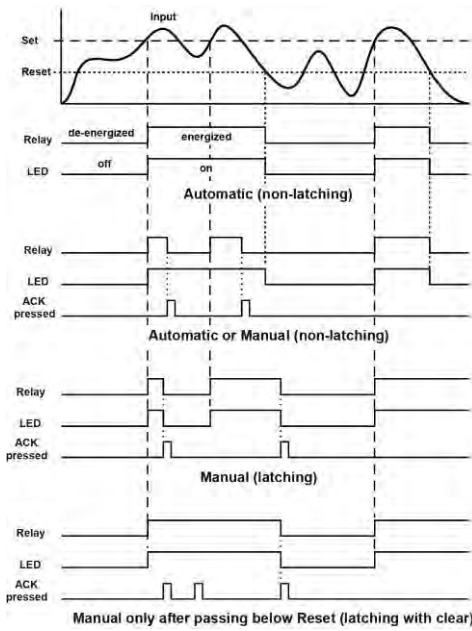

Low Alarm Operation (Set < Reset)

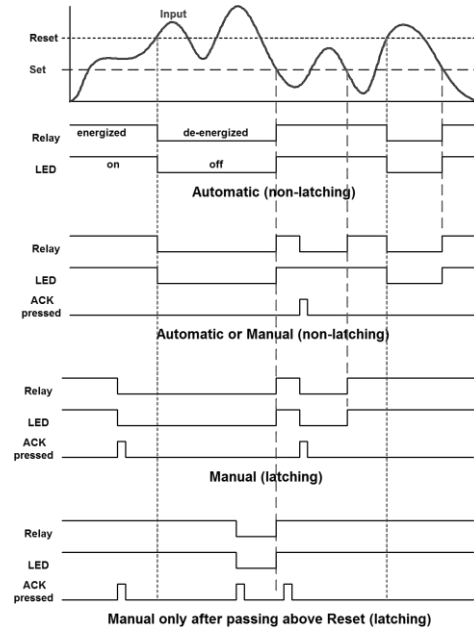

For Manual reset mode, ACK can be pressed anytime to turn "off" relay. To detect a new alarm condition, the signal must go below the set point, and then go above it.

High Alarm with Fail-Safe Operation (Set > Reset)

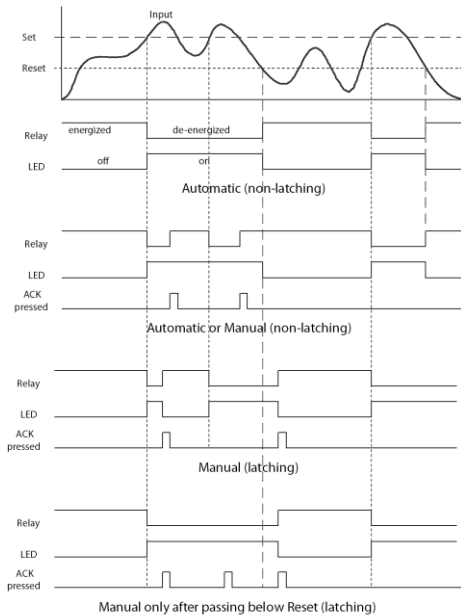

Low Alarm with Fail-Safe Operation (Set < Reset)

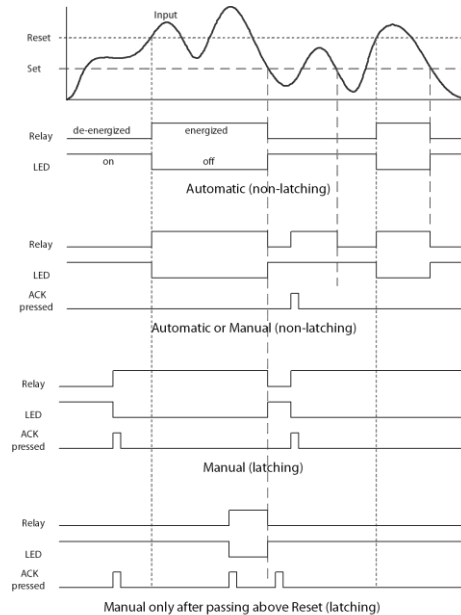

Note: Relay coil is energized in non-alarm condition. In case of power failure, relay will go to alarm state.

Pump Alternation Control Operation

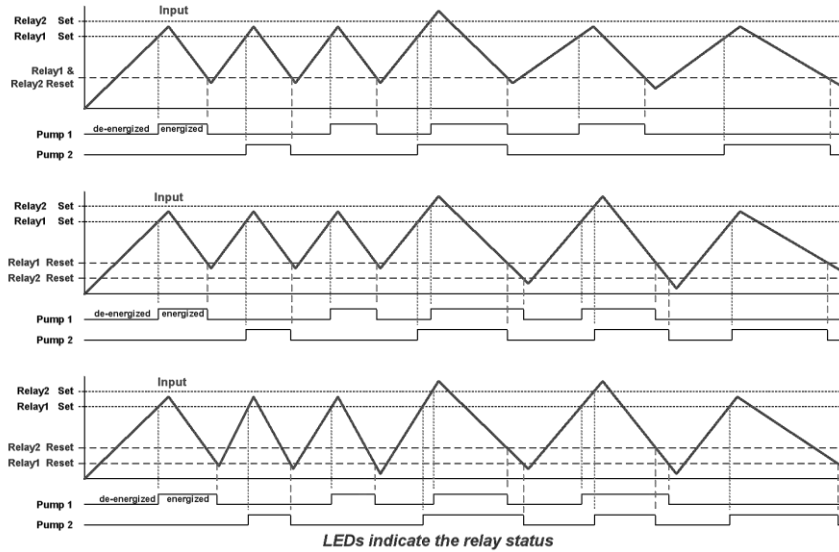

Rate Relay Sampling Operation

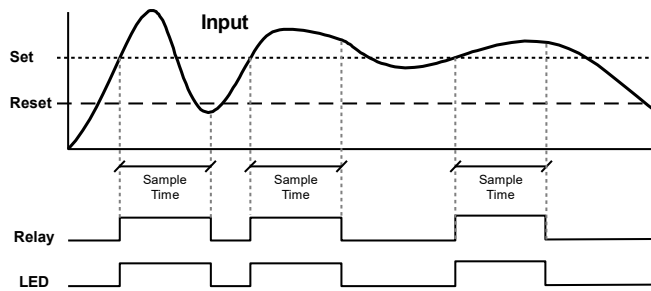

When the signal crosses the set point, the relay trips and the sample time starts. After the sample time has elapsed, the relay resets. The cycle repeats every time the set point is crossed, going up for high alarms and going down for low alarms.

The sample time can be programmed between 0.1 and 5999.9 seconds.

Total Relay Sampling Operation

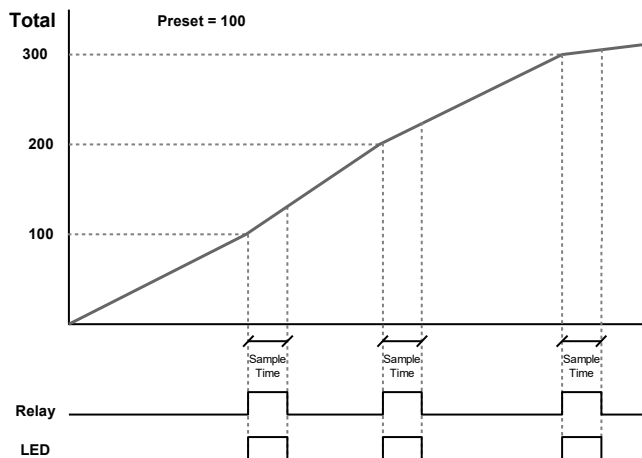

When the total reaches the preset, the relay trips and the sample time starts. After the sample time has elapsed, the relay resets. The cycle repeats every time the preset value is added to the total.

Time Delay Operation

The following graphs show the operation of the time delay function.

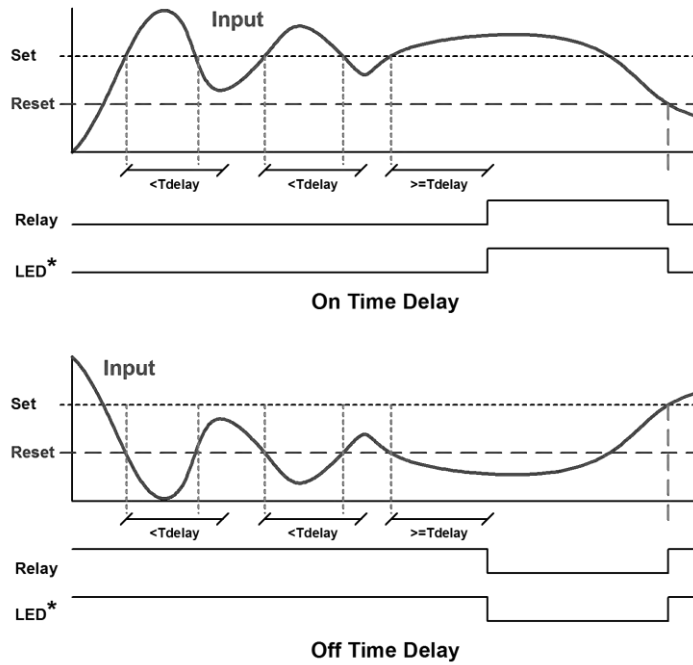

When the signal crosses the set point, the *On* time delay timer starts and the relay trips when the time delay has elapsed. If the signal drops below the set point (high alarm) before the time delay has elapsed, the *On* time delay timer resets and the relay does not change state. The same principle applies to the *Off* time delay.

Note: If "Automatic or Manual" (R-n-Rn) reset mode is selected, the LED follows the reset point and not the relay state when the relay is acknowledged.

Relay Operation Details

Overview

The relay capabilities of the meter expand its usefulness beyond simple indication to provide users with alarm and control functions. These capabilities include front panel alarm status LEDs as well as either 2 or 4 optional internal relays and/or 4 external relays expansion module. Typical applications include high or low flow alarms and basic batch control. There are four basic ways the relays can be used:

1. High or Low Alarms with Latching or Non-Latching Relays
2. Simple On/Off Control with 100% Adjustable Deadband
3. Sampling (Based on Time)
4. Alternation Control for up to 8 Relays

Relays Auto Initialization

When power is applied to the meter, the front panel LEDs and alarm relays will reflect the state of the input to the meter. The following table indicates how the alarm LEDs and relays will react on power-up based on the set and reset points:

Alarm #	HI or LO Alarm	Set Point	Reset Point	Power-Up Reading	Relay & LED
1	HI	1000	500	499	Off
2	LO	700	900	499	On
3	LO	250	400	499	Off
4	HI	450	200	499	On

Fail-Safe Operation

The following table indicates how the relays behave based on the fail-safe selection for each relay:

Note: NO = Normally Open, NC = Normally Closed. This refers to the condition of the relay contacts when the power to the meter is off.

Fail-Safe Selection	Non-Alarm State		Alarm State		Power Failure
	NO	NC	NO	NC	
Off	Open	Closed	Closed	Open	Relays go to non-alarm state
On	Closed	Open	Open	Closed	Relays go to alarm state

Front Panel LEDs

The LEDs on the front panel provide status indication for the following:

The meter is supplied with four alarm points that include front panel LEDs to indicate alarm conditions. This standard feature is particularly useful for alarm applications that require visual-only indication. The LEDs are controlled by the set and reset points programmed by the user. When the display reaches a set point for a high or low alarm, the corresponding alarm LED will turn on. When the display returns to the reset point the LED will go off. The front panel LEDs respond differently for latching and non-latching relays.

LED	Status
1	Alarm 1
2	Alarm 2
3	Alarm 3
4	Alarm 4

LED	Status
5	Alarm 5
6	Alarm 6
7	Alarm 7
8	Alarm 8

For non-latching relays, the LED is always off during normal condition and always on during alarm condition, regardless of the state of the relay (e.g. Relay acknowledged after alarm condition).

For latching relays, the alarm LEDs reflects the status of the relays, regardless of the alarm condition. The following tables illustrate how the alarm LEDs function in relation to the relays and the acknowledge button (Default: F3 key assigned to ACK):

Latching and Non-Latching Relay Operation

The relays can be set up for latching (manual reset) or non-latching (automatic reset) operation.

The On and Off terminology does not refer to the status of the relay's coil, which depends on the fail-safe mode selected.

Relay terminology for following tables	
Terminology	Relay Condition
On	Alarm (Tripped)
Off	Normal (Reset)
Ack	Acknowledged



Warning! *In latching relay mode, latched relays will reset (unlatch) when power is cycled.*

Non-Latching Relay (Automatic reset)

In this application, the meter is set up for automatic reset (non-latching relay). Acknowledging the alarm while it is still present has no effect on either the LED or the relay. When the alarm finally goes away, the relay automatically resets and the LED also goes off.

Automatic reset only		
Condition	LED	Relay
Normal	Off	Off
Alarm	On	On
Ack (No effect)	On	On
Normal	Off	Off

Non-Latching Relay (Automatic + manual reset)

In this application, the meter is set up for automatic and manual reset at any time (non-latching relay). The LED and the relay automatically reset when the meter returns to the normal condition.

The next time an alarm occurs, the operator acknowledges the alarm manually while the alarm condition still exists. This causes the relay to reset, but the LED stays on until the meter returns to the normal condition.

Automatic + manual reset at any time		
Condition	LED	Relay
Normal	Off	Off
Alarm	On	On
Normal	Off	Off
Next Alarm	On	On
Ack	On	Off
Normal	Off	Off

Latching Relay (Manual reset)

In this application, the meter is set up for manual reset at any time. Acknowledging the alarm even if the alarm condition is still present resets the relay and turns off the LED.

Manual reset any time		
Condition	LED	Relay
Normal	Off	Off
Alarm	On	On
Ack	Off	Off

Latching Relay (Manual reset only after alarm cleared)

In this application, the meter is set up for manual reset only after the signal passes the reset point (alarm condition has cleared). Acknowledging the alarm while it is still present has no effect on either the LED or the relay. When the alarm is acknowledged after it returns to the normal state, the LED and the relay go off. Notice that the LED remains on, even after the meter returns to the normal condition. This is because, for latching relays, the alarm LED reflects the status of the relay, regardless of the alarm condition.

Manual reset only after alarm condition has cleared		
Condition	LED	Relay
Normal	Off	Off
Alarm	On	On
Ack (No effect)	On	On
Normal	On	On
Ack	Off	Off

Acknowledging Relays

There are two ways to acknowledge relays programmed for manual reset:

1. Via the programmable front panel function keys F1-F3 (Default: F3 assigned to ACK).
2. Remotely via a normally open pushbutton wired across one of the digital inputs and the +5 V terminals on the digital I/O modules, or using the F4 digital input, which is triggered with a contact closure to COM, or with an active low signal (see page 14).

When the ACK button or the assigned digital input is closed, all relays programmed for manual reset are acknowledged.

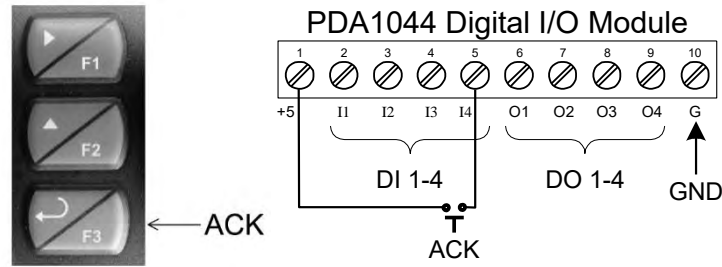
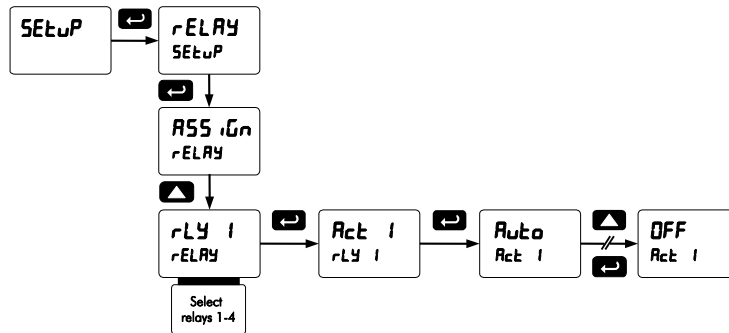

Figure 22: Acknowledge Relays w/Function Key or Digital Input

Setting Up the Interlock Relay (Force On) Feature

Relays 1-4 can be set up as interlock relays. To set up the relays for the interlock feature:

1. Access the *Setup – Relay – Action* menu and set the action to off.



2. In the *Advanced features – User* menu program any of the digital inputs to *Force On* any of the internal relays (1-4).



3. Connect a switch or dry contact between the +5V terminal and the corresponding digital input (DI-1 to DI-4) terminal.

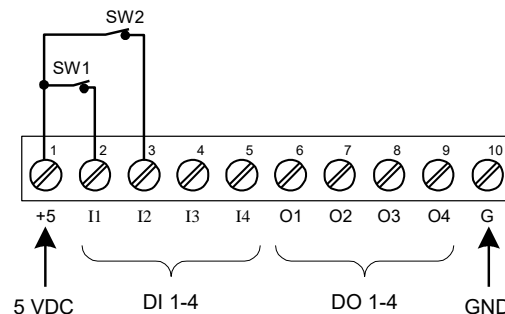

Interlock Relay Operation Example

Relays 1 & 2 are configured to energize (their front panel LEDs are off) when SW1 & SW2 switches (above) are closed. If the contacts to these digital inputs are opened, the corresponding front panel LEDs flash indicating this condition. The processes being controlled by the interlock relay will stop, and will re-start only after the interlock relay is re-activated by the digital inputs (switches).

Note: If multiple digital inputs are assigned to the same relay, then the corresponding logic is (AND) – i.e. both switches must be closed to trip the relay.

Scaling the 4-20 mA Analog Output (Rout)

The 4-20 mA analog output can be scaled to provide a 4-20 mA signal for any display range selected.

No equipment is needed to scale the analog output; simply program the display values to the corresponding mA output signal.

The *Analog Output* menu is used to program the 4-20 mA output based on display values.

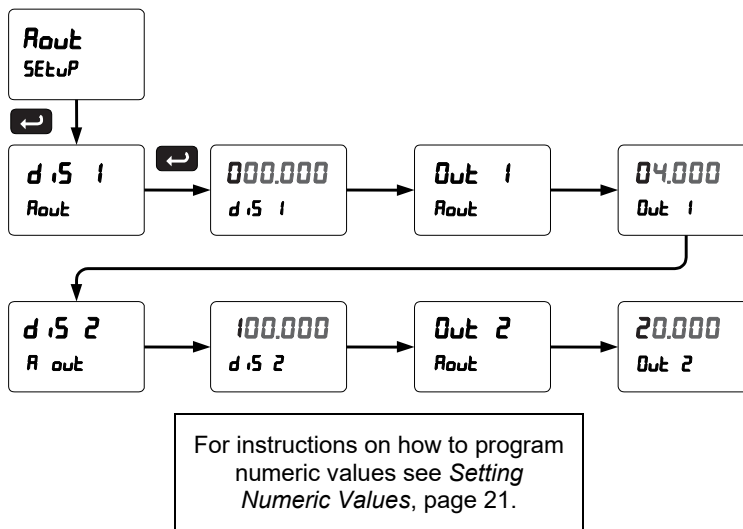

Reset Menu (rESEt)

The *Reset* menu is used to reset the totals, maximum or minimum reading (peak or valley) reached by the process; both may be reset at the same time by selecting “reset high & low” (rSE HL).

Control Menu (Contrl)

The *Control* menu is used to control the 4-20 mA analog output and the relays manually, ignoring the input. Each relay and analog output can be programmed independently for manual control. Selecting automatic control sets all relays and the analog output for automatic operation.

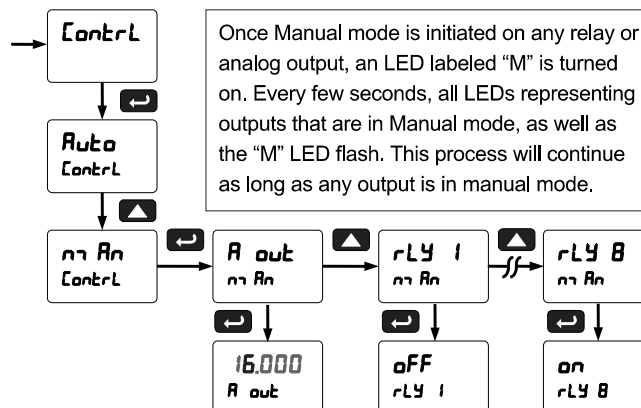

Setting Up the Password (PASS)

The *Password* menu is used for programming three levels of security to prevent unauthorized changes to the programmed parameter settings and to program the non-resettable totalizer.

Pass 1: Allows use of function keys and digital inputs
 Pass 2: Allows use of function keys, digital inputs and editing set/reset points
 Pass 3: Restricts all programming, function keys, and digital inputs.
 Total: Prevents resetting the total manually
 Gtotal: Prevents resetting the grand total manually

Protecting or Locking the Meter

Enter the *Password* menu and program a six-digit password.

For instructions on how to program numeric values see *Setting Numeric Values*, page 21.

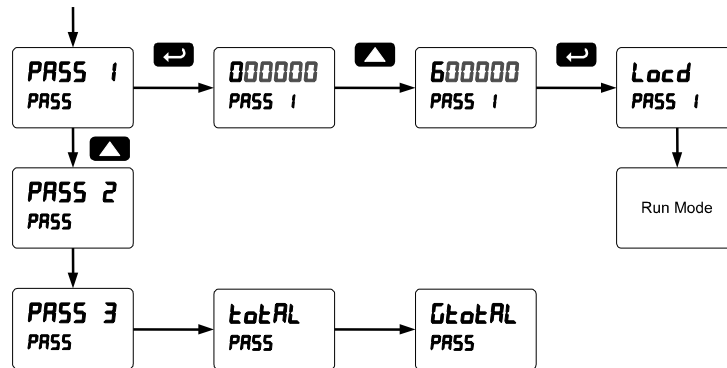

Total Reset Password & Non-Resettable Total

The total and the grand total can be password-protected to prevent unauthorized total resets.

The grand total can be programmed as a non-resettable total by entering the password "050873".

 **Caution!** Once the Grand Total has been programmed as "non-resettable" the feature **cannot** be disabled.

Making Changes to a Password Protected Meter

If the meter is password protected, the meter will display the message *Locd* (*Locked*) when the Menu button is pressed. Press the Enter button while the message is being displayed and enter the correct password to gain access the menu. After exiting the programming mode, the meter returns to its password protected condition.

Disabling Password Protection

To disable the password protection, access the *Password* menu and enter the correct password twice, as shown below. The meter is now unprotected until a new password is entered.

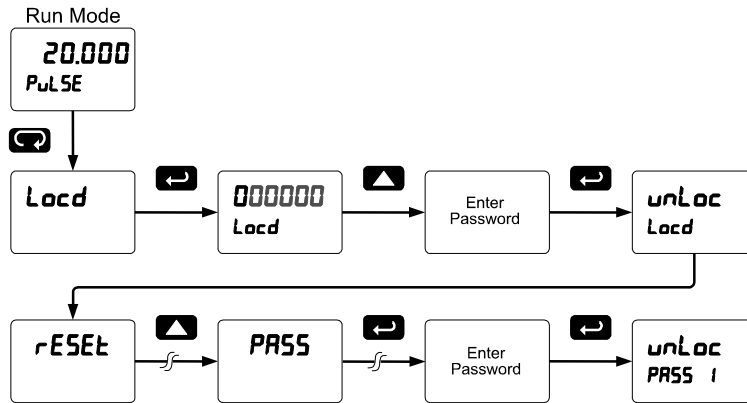

If the correct six-digit password is entered, the meter displays the message *unLoc* (*unlocked*) and the protection is disabled until a new password is programmed.

If the password entered is incorrect, the meter displays the message *Locd* (*Locked*) for about two seconds, and then it returns to Run Mode. To try again, press Enter while the *Locked* message is displayed.

Did you forget the password?

The password may be disabled by entering a master password once. If you are authorized to make changes, enter the master password 508655 to unlock the meter.

Advanced Features Menu

To simplify the setup process, functions not needed for most applications are located in the *Advanced Features* menu.

Press and hold the Menu button for three seconds to access the advanced features of the meter.

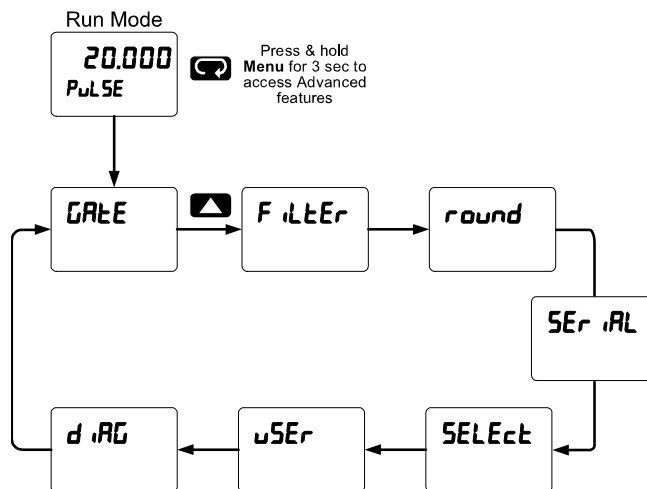

Advanced Features Menu & Display Messages

The following table shows the functions and messages of the *Advanced Features* menu in the order they appear in the menu.

Display	Parameter	Action/Setting
GATE	Gate	Enter Gate function menu
Lo G	Low gate	Program Low gate value
Hi G	High gate	Program High gate value
FILTER	Filter	Enter the Filter menu
Lo SPD	Low speed	Set the contact de-bounce filter value
Hi SPD	High speed	Select high speed filter
round	Round	Set the rounding value for display variables
SERIAL	Serial	Set serial communication parameters
SLAVE ID	Slave ID	Set slave ID or meter address
baud	Baud rate	Select baud rate
tr dLY	Transmit delay	Set transmit delay for serial communication
PARITY	Parity	Select parity: Even, Odd, or None with 1 or 2 stop bits
t-bytE	Time byte	Set byte-to-byte timeout
SELEct	Select	Enter the Select menu (function, cutoff, out)
FunctiOn	Signal input conditioning	Select linear only, other functions are not applicable to pulse input
LineAR	Linear	Set meter for linear function and select number of linearization points

Display	Parameter	Action/Setting
no Pts	Number of points	Set meter for 2 to 32-point linearization
Cutoff	Cutoff	Set low-flow cutoff
Count	Count	Set the totals to count up or down from a set value
tot C	Total count	Set the total to count up to or down from the programmed total value
Grand C	Grand total count	Set the grand total to count up or down from from the programmed grand total value
Analog Pr	Analog output programming	Program analog output parameters
Source	Source	Select source for the 4-20 mA output
Overrange	Overrange	Program mA output for display overrange
Underrange	Underrange	Program mA output for display underrange
max MA	Maximum	Program maximum mA output allowed
min MA	Minimum	Program minimum mA output allowed
CALIB	Calibrate	Calibrate 4-20 mA output (internal reference source used for scaling the output)

Display	Parameter	Action/Setting
4 mA R	4 mA output	Enter mA output value read by milliamp meter with at least 0.001 mA resolution
20 mA R	20 mA output	Enter mA output value read by milliamp meter with at least 0.001 mA resolution
uSEr	User I/O	Assign function keys and digital I/O
F 1	F1 function key	Assign F1 function key
F 2	F2 function key	Assign F2 function key
F 3	F3 function key	Assign F3 function key

Display	Parameter	Action/Setting
F4	F4 function	Assign F4 function (digital input)
d i 1	Digital input 1	Assign digital input 1 – 8, if expansion modules are connected
d o 1	Digital output 1	Assign digital output 1 – 8, if expansion modules are connected
d iRG	Diagnostics	Display parameter settings
LED t	LED test	Test all LEDs
inFo	Information	Display software and S/N information
ErASE	Erase	Erase MeterView Pro software stored in meter's memory

Rounding Feature (round)

The rounding feature is used to give the user a steadier display with fluctuating signals. Rounding is used in addition to the filter function.

Rounding causes the display to round to the nearest value according to the rounding selected. This setting affects the last two digits, regardless of decimal point position.

Modbus RTU Serial Communications (SEr ,AL)

The meter is equipped with serial communications capability as a standard feature using Modbus RTU Serial Communication Protocol.

The meter may be connected to a PC for initial configuration via the onboard micro USB connection. For ongoing digital communications with a computer or other data terminal equipment, an RS-232, or RS-485 option is required; see *Ordering Information* on page 5 for details.



Warning! Do not connect any equipment other than Precision Digital's expansion modules, cables, or meters to the RJ45 M-LINK connector. Otherwise damage will occur to the equipment and the meter.

Note: More detailed instructions are provided with each optional serial communications adapter. Note: Refer to the ProVu® Modbus Register Tables located at www.predig.com for details.

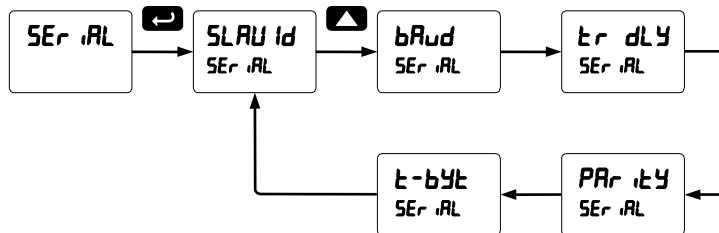

When using more than one meter in a multi-drop mode, each meter must be provided with its own unique address. The meter address (Slave ID) may be programmed between 1 and 247. The transmit delay may be set between 0 and 199 ms. The parity can be set to even, odd, or none with 1 or 2 stop bits.

Select Menu (SELEct)

The *Select* menu is used to select the signal input conditioner applied to the input (linear), low-flow cutoff, and analog output programming. The multi-point linearization is part of the linear function selection.

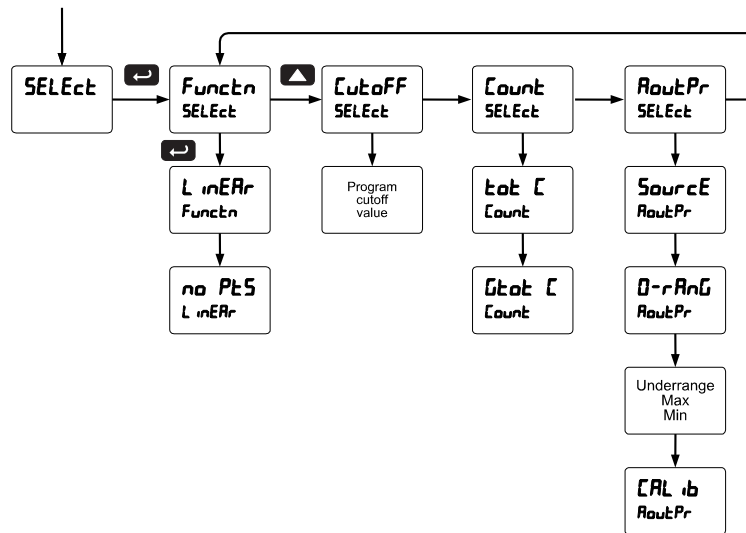

Signal Input Conditioning (Functn)

The *Function* menu is used to select the signal input conditioner applied to the input: linear, where the multi-point linearization is part of the linear function selection.

Meters are set up at the factory for linear function with 2-point linearization. The linear function provides a display that is linear with respect to the input signal.

Multi-Point Linearization (L inERr)

Meters are set up at the factory for linear function with 2-point linearization. Up to 32 linearization points can be selected under the linear function. The multi-point linearization can be used to linearize the display for non-linear signals.

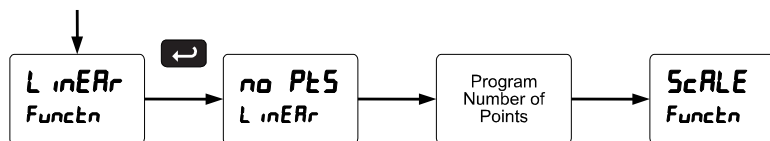

Low-Flow Cutoff (Cutoff)

The low-flow cutoff feature allows the meter to be programmed so that the often-unsteady output from a differential pressure transmitter, at low flow rates, always displays zero on the meter.

The cutoff value may be programmed from 0 to 999999. The meter will display zero below the cutoff value. Programming the cutoff value to zero disables the cutoff feature.

Analog Output Programming (RoutPr)

The *Analog Output Programming* menu is used to program the behavior of the 4-20 mA output. The following parameters and functions are programmed in this menu:

1. Source: Source for generating the 4-20 mA output (e.g. PV)
2. Overrange: Analog output value with display in overrange condition
3. Underrange: Analog output value with display in underrange condition
4. Max: Maximum analog output value allowed regardless of input
5. Min: Minimum analog output value allowed regardless of input
6. Calibrate: Calibrate the internal 4-20 mA source reference used to scale the 4-20 mA output

Analog Output Source

The source for generating the 4-20 mA output may be assigned to the rate/process variable, total, grand total, maximum or minimum value reached by the rate/process, one of the set points, or the Modbus PV input.

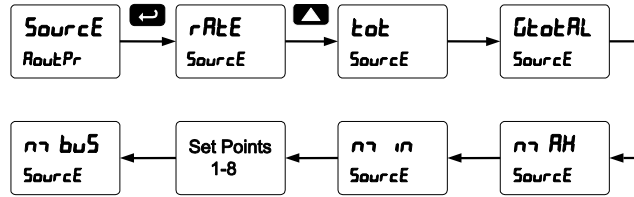

Analog Output Calibration

To perform the analog output calibration, it's recommended to use a milliamp meter with a resolution of at least 0.1 μ A to measure the output current. The values saved internally during this procedure are used for scaling the 4-20 mA output in the *Setup* menu.

Programmable Function Keys User Menu (uSEr)

The *User* menu allows the user to assign the front panel function keys F1, F2, and F3, the digital input F4 (a digital input located on the signal input connector), and up to eight additional digital inputs to access most of the menus or to activate certain functions immediately (e.g. reset max & min, hold relay states, etc.). This allows the meter to be greatly customized for use in specialized applications.

Up to eight digital outputs can be assigned to a number of actions and functions executed by the meter (i.e. alarms, relay acknowledgement, reset max, min, or max & min, tare, and reset tare). The digital outputs can be used to trigger external alarms or lights to indicate these specific events.

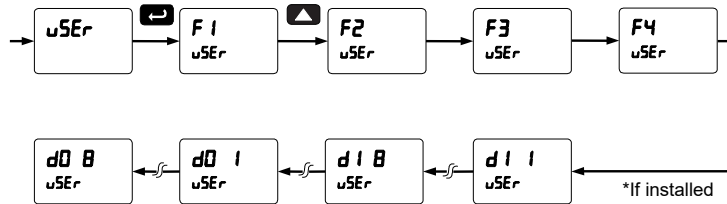

Function Keys & Digital I/O Available Settings

Refer to the following table for descriptions of each available function key or digital I/O setting.

Display	Description	Display	Description
rELRY	Directly access the relay menu	፮ጠ፩፫	Directly access the control menu
፮፫፩ *	Directly access the set point menu for relay 1 (*through 8)	d,፮፫፩	Disable the selected function key or digital I/O
rLY d	Disable all relays until a button assigned to <i>enable relays (rLY E)</i> is pressed	፫፫	Acknowledge all active relays that are in a manual operation mode such as auto-manual or latching
rLY E	Enable all relays to function as they have been programmed	r፫፫፫፫	Directly access the reset menu
፫ ፫፫፩	Hold current relay states and analog output as they are until a button assigned to <i>enable relays (rLY E)</i> is pressed	r፮፫ ፫	Reset the total
d ፫፫፩	Hold the current display value, relay states, and analog output momentarily while the function key or digital input is active. The process value will continue to be calculated in the background.	r፮፫ ፮፫	Reset the grand total
፫፫ ፫፫	Display maximum display value on line 1	r፮፫ ፫፫	Reset the stored maximum display value
፫፫ ፫፫	Display minimum display value on line 1	r፮፫ ፫፫	Reset the stored minimum display value
፫፫ ፫፫	Display maximum & minimum display values on line 1	r፮፫ ፫፫	Reset the stored maximum & minimum display values
፫፫፫ ፫፫	Display maximum display value on line 2	d፮፫፫፫	Directly access the display menu
፫፫፫ ፫፫	Display minimum display value on line 2	፫፫፫ ፫	Directly access the display line 1 menu
፫፫፫ ፫፫	Display maximum & minimum display values on line 2	፫፫፫ ፫፫	Directly access the display line 2 menu
፫፫፫ ፮፫	Display the grand total on line 2	፫፫፫፫	Mimic the menu button functionality (digital inputs only)
F ፫፫ *	Force relay 1 (*through 4) into the on state. This function is used in conjunction with a digital input expansion module to achieve interlock functionality. See page 36 for details about interlock relays.	r፫፫፫፫	Mimic the right arrow/F1 button functionality (digital inputs only)
		፫፫	Mimic the up arrow/F2 button functionality (digital inputs only)
		፫፫፫፫	Mimic the enter/F3 button functionality (digital inputs only)
		፫፫፫ ፫*	Provide indication when alarm 1 (*through 8) has been triggered (digital outputs only)





Meter Operation

The meter accepts pulses (e.g. $\pm 40\text{mV}$ to $\pm 8\text{V}$), square wave (0-5, 0-12V, or 0-24V), open collector NPN, PNP, TTL, or switch contact signals and displays these signals in engineering units from -99999 to 999999.

The dual-line display can be customized by the user to operate in such a way as to satisfy a specific application. Typically, line 1 is used for the process variable; while line 2 is used for engineering units, custom legend, total, grand total, or set point indication.

The meter can be set up to display the pulse input on line 1 and the Modbus input on line 2. The relays and analog output can be programmed to operate from the Modbus PV input.

Front Panel Buttons Operation

Button Symbol	Description
	Press to enter or exit Programming Mode, view settings, or exit max/min readings
	Press to reset max/min readings or other parameter/function assigned through the <i>User</i> menu
	Press to display max/min readings or other parameter/function assigned through the <i>User</i> menu
	Press to acknowledge relays or other parameters/function assigned through the <i>User</i> menu

Function Keys Operation

During operation, the programmable function keys operate according to the way they have been programmed in the *Advanced Features – User* menu.

The table above shows the factory default settings for F1, F2, and F3.

F4 Operation

A digital input, F4, is standard on the meter. This digital input is programmed identically to function keys F1, F2, and F3. The input is triggered with a contact closure to COM, or with an active low signal. During operation, F4 operates according to the way it has been programmed in the *Advanced Features – User* menu.

Maximum/Minimum Readings

The max & min readings (peak & valley) reached by the process can be displayed either continuously or momentarily:

1. Display briefly by assigning to the F1-F3 function keys, F4 (digital input) or to the digital inputs in the *User* menu.
2. Display continuously by assigning either display to max/min through the *Display* menu.

Any of the F1-F3 function keys (buttons), F4 (digital input), and the digital inputs can be programmed to reset the max & min readings. The meters are set at the factory to display the max reading by pressing the Up arrow/F2 button and to use the Right arrow/F1 button to access the *Reset* menu.

To display max reading using function key with factory defaults:

1. Press Up arrow/F2 button to display maximum reading since the last reset/power-up.
2. To reset max/min press Right arrow/F1 button to access the Reset menu. The max & min displays are reset to actual values.
3. Press Menu to exit max/min display reading.

To display max/min readings continuously:

Assign either display to Max (*d H i*), Min (*d L o*), or toggle between Max and Min (*d H L*) every 10 seconds.

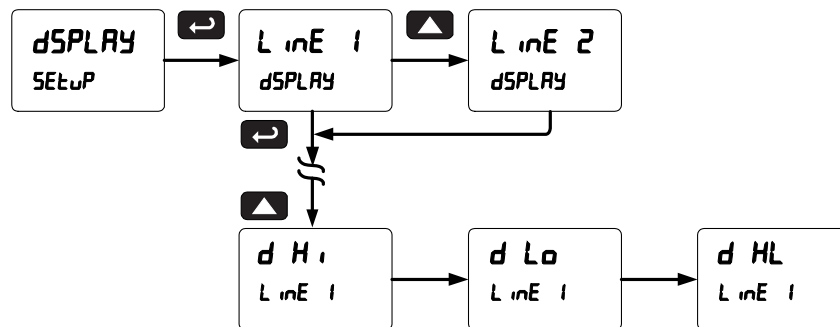

Troubleshooting

The rugged design and the user-friendly interface of the meter should make it unusual for the installer or operator to refer to this section of the manual. However, due to the many features and functions of the meter, it's possible that the setup of the meter does not agree with what an operator expects to see. If the meter is not working as expected, refer to the *Diagnostics* menu and recommendations below.

Diagnostics Menu (d rG)

The *Diagnostics* menu is located in the *Advanced Features* menu, to access *Diagnostics* menu see *Advanced Features Menu*, page 40.

This menu allows the user to test the functionality of all the meter LEDs, check the meter's software and version information, and erase the MeterView Pro software installation files from the meter. Press the Enter button to view the settings and the Menu button to exit at any time.

For a description of the diagnostic messages, see *Advanced Features Menu & Display Messages*, page 40.

Determining Software Version

To determine the software version of a meter:

1. Go to the *Diagnostics* menu (d rG) and press Enter button.
2. Press Up arrow button and scroll to Information menu (InFo).
3. Press Enter to access the software number (5Ft) and version (vEr) information. Write down the information as it is displayed. Continue pressing Enter until all the information is displayed.
4. The meter returns to Run Mode after displaying all the settings.

Reset Meter to Factory Defaults

When the parameters have been changed in a way that is difficult to determine what's happening, it might be better to start the setup process from the factory defaults.

Instructions to load factory defaults:

1. Enter the *Advanced Features* menu. See *Advanced Features Menu*, page 40.
2. Press Up arrow to go to *Diagnostics* menu
3. Press and hold Right arrow for three seconds, press Enter when display flashes rESEt.
Note: If Enter is not pressed within three seconds, the display returns to the *Diagnostics* menu.
4. The meter goes through an initialization sequence (similar as on power-up), and loads the factory default settings.

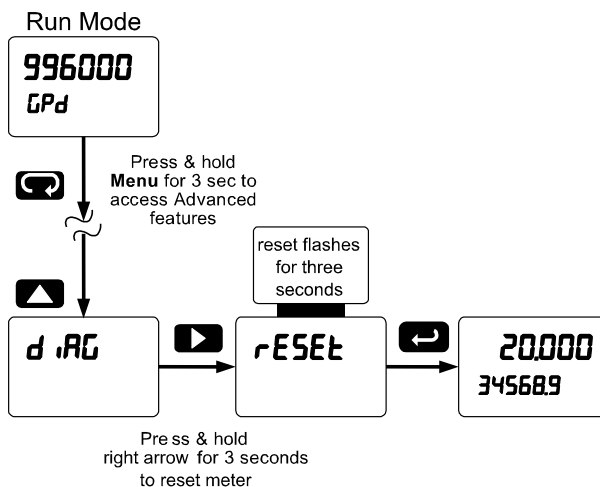

Factory Defaults & User Settings

The following table shows the factory setting for most of the programmable parameters on the meter.

Parameter	Display	Default Setting	Parameter	Display	Default Setting
Input type	INPUL	Pulse	Relay 1 set point	SEt 1	100.0
Total	YES	Total enabled	Relay 1 reset point	rSEt 1	000.0
Units	units	Rate / total / gr. total pulse / pulse / pulse	Relay 2 action	Act 2	Automatic
Filter	FILTEr	Hi Spd	Relay 2 set point	SEt 2	200.0
K-factor	FACTOR	1.000	Relay 2 reset point	rSEt 2	000.0
Function	FUNCTION	Linear	Relay 3 action	Act 3	Automatic
Number of points	no Pts	2	Relay 3 set point	SEt 3	300.0
Input 1	INP 1	00000.0	Relay 3 reset point	rSEt 3	250.0
Display 1	dis 1	00000.0	Relay 4 action	Act 4	Automatic
Input 2	INP 2	10000.0	Relay 4 set point	SEt 4	400.0
Display 2	dis 2	10000.0	Relay 4 reset point	rSEt 4	350.0
Decimal point	dddddd	1 place	Fail-safe relay 1	FLS 1	Off
Cutoff value	CUTOFF	0.000 (disabled)	Fail-safe relay 2	FLS 2	Off
Display assignment	DISPLAY		Fail-safe relay 3	FLS 3	Off
Display line 1	LINE 1	Rate/Process	Fail-safe relay 4	FLS 4	Off
Display line 2	LINE 2	Total value	On delay relay 1	On 1	0.0 sec
Display intensity	diNtY	8	Off delay relay 1	OFF 1	0.0 sec
Total time base	t tb	Second	On delay relay 2	On 2	0.0 sec
Total conversion factor	t CF	1.000	Off delay relay 2	OFF 2	0.0 sec
Total reset	t rSEt	Manual	On delay relay 3	On 3	0.0 sec
Grand total time base	Gr t tb	Second	Off delay relay 3	OFF 3	0.0 sec
Grand total conversion factor	Gr t CF	1.000	On delay relay 4	On 4	0.0 sec
Grand total reset	Gr t rSEt	Manual	Off delay relay 4	OFF 4	0.0 sec
Relay 1 assignment	RS 1n1	Total	Display 1 analog out	dis 1	0.0
Relay 2 assignment	RS 1n2	Total	Output 1 value	Out 1	4.000 mA
Relay 3 assignment	RS 1n3	Rate	Display 2 analog out	dis 2	1000.0
Relay 4 assignment	RS 1n4	Rate	Output 2 value	Out 2	20.000 mA
Relay 1 action	Act 1	Automatic	Source analog output	Source	Rate/process
			Overrange output	ORRNG	21.000 mA

Parameter	Display	Default Setting
Underrange output	u-r RnG	3.000 mA
Maximum output	max RH	23.000 mA
Minimum output	min m	1.000 mA
Slave ID (Address)	SLAVE id	247
Baud rate	baud	9600
Transmit delay	tr dLY	50 ms
Parity	PAR itY	Even
Byte-to-byte timeout	t-bytE	010 (0.1 sec)
F1 function key	F 1	Reset max & min
F2 function key	F 2	Line 1: Max (Hi)
F3 function key	F 3	Acknowledge relays
F4 function	F 4	Acknowledge relays

Parameter	Display	Default Setting
Digital input 1	d i 1	Menu
Digital input 2	d i 2	Right arrow
Digital input 3	d i 3	Up arrow
Digital input 4	d i 4	Enter
Digital output 1	dO 1	Alarm 1
Digital output 2	dO 2	Alarm 2
Digital output 3	dO 3	Alarm 3
Digital output 4	dO 4	Alarm 4
Password 1	PA55 1	000000 (unlocked)
Password 2	PA55 2	000000 (unlocked)
Password 3	PA55 3	000000 (unlocked)
Total password	tOtAL	000000 (unlocked)
Grand total password	GtOtAL	000000 (unlocked)

Troubleshooting Tips

Symptom	Check/Action
No display at all	Check power at power connector
Not able to change setup or programming, <code>Locd</code> is displayed	Meter is password-protected, enter correct six-digit password to unlock
Meter displays error message during calibration (<code>Error</code>)	Check: 1. Signal connections 2. Minimum input span requirements
Meter displays <code>999999</code> <code>-999999</code>	Check: 1. Input selected in <i>Setup</i> menu 2. Corresponding signal at Signal connector
Display is unstable	Check: 1. Input signal stability and value 2. Display scaling vs. input signal 3. Filter and gate values
Display response is too slow	Check filter and gate values
Display reading is not accurate	Check: Scaling or calibration
Display does not respond to input changes, reading a fixed number	Check: Display assignment, it might be displaying max, min, or set point.
Display alternates between 1. <code>Hi</code> and a number 2. <code>Lo</code> and a number	Press Menu to exit max/min display readings.
Relay operation is reversed	Check: 1. Fail-safe in <i>Setup</i> menu 2. Wiring of relay contacts
Relay and status LED do not respond to signal	Check: 1. Relay action in <i>Setup</i> menu 2. Set and reset points
Flashing relay status LEDs	Relays in manual control mode or relay interlock switches opened.
Meter not communicating with application programs	Check: 1. Serial adapter and cable 2. Serial settings 3. Meter Slave ID and baud rate
If the display locks up or the meter does not respond at all	Cycle the power to reboot the microprocessor.
Other symptoms not described above	Call Technical Support for assistance.

Note: Certain sequences of events can cause unexpected results. To solve these issues, it is best to start fresh from factory defaults and map changes ahead of time, rather than at random.



EU Declaration of Conformity

Issued in accordance with ISO/IEC 17050-1:2004.

We,

Precision Digital Corporation
233 South Street
Hopkinton, MA 01748 USA

as the manufacturer, declare under our sole responsibility that the product(s),

Model PD6300 ProVu Series Pulse Input Rate/Totalizer Meter

to which this declaration relates, is in conformity with the European Union Directives shown below:

2014/35/EU	Low Voltage Directive
2014/30/EU	EMC Directive
2011/65/EU	RoHS Directive

This conformity is based on compliance with the application of harmonized or applicable technical standards and, when applicable or required, a European Union notified body certification.

Standards:

EN 55022:2003
EN 61000-6-2:2001
EN 61010-1:2001
EN 61326:2006

The standards EN 55022:2003, EN 61000-6-2:2001, EN 61010-1:2001, and EN 61326:2006 are no longer harmonized. The requirements of these standards have been checked against the harmonized standards EN 55022:2010, EN 61000-6-2:2005, EN 61010-1:2010, and EN 61326:2013 and there were no major technical changes affecting the latest technical knowledge for the products listed above.

Product Markings:



Signed for and on behalf of Precision Digital Corporation:

Name: Jeffrey Peters
Company: Precision Digital Corporation
Title: President
Date: 04/20/2016

Document No: DoC PD6300 {042016}

How to Contact Precision Digital

- For Technical Support, please
Call: (800) 610-5239 or (508) 655-7300
Fax: (508) 655-8990
Email: support@predig.com
- For Sales Support or to place an order, please
Call: (800) 343-1001 or (508) 655-7300
Fax: (508) 655-8990
Email: sales@predig.com
- For the latest version of this manual, please visit
www.predig.com

Order from:

C A Briggs Company

622 Mary Street; Suite 101

Warminster, PA 18974

Phone: 267-673-8117 - Fax: 267-673-8118

Sales@cabriggs.com - www.cabriggs.com

PRECISION DIGITAL CORPORATION

233 South Street • Hopkinton MA 01748 USA

Tel (800) 343-1001 • Fax (508) 655-8990



www.predig.com