

Helios Large Display Feet & Inches Meter

Instruction Manual

PD2-6001



HELIOS



Feet & Inches

- Large 1.80" Digits
- Dual-Line 6-Digit Display
- Readable from up to 100 Feet (30 Meters) Away
- Superluminous Sunlight Readable Display
- NEMA 4X, IP65 Rated Field Mountable Enclosure
- Operating Temperature Range of -40 to 65°C (-40 to 150°F)
- Feet and Inches Display Ideal for Level Applications
- 0-20 mA, 4-20 mA, 0-5 V, 1-5 V, and ± 10 V Inputs
- Input Power Options Include 85-265 VAC or 12-24 VDC
- Dual-Scale for some Level Applications – Single Input
- Isolated 24 VDC Transmitter Power Supply
- Multi-Pump Alternation Control
- Four (4) Relays + Isolated 4-20 mA Output Options
- Onboard USB & RS-485 Serial Communication Options
- Modbus® RTU Communication Protocol Standard
- Program the Meter from a PC with onboard USB and MeterView Pro

PRECISION DIGITAL CORPORATION

233 South Street • Hopkinton MA 01748 USA
Tel (800) 343-1001 • Fax (508) 655-8990

Order from: **C A Briggs Company**

622 Mary Street; Suite 101; Warminster, PA 18974
Phone: 267-673-8117 - Fax: 267-673-8118



Sales@cabriggs.com - www.cabriggs.com



www.predig.com

Disclaimer

The information contained in this document is subject to change without notice. Precision Digital makes no representations or warranties with respect to the contents hereof and specifically disclaims any implied warranties of merchantability or fitness for a particular purpose.

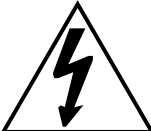
 <p>Caution: <i>Read complete instructions prior to installation and operation of the meter.</i></p>	 <p>Warning: <i>Risk of electric shock or personal injury.</i></p>
 <p>Warning!</p>	<p><i>This product is not recommended for life support applications or applications where malfunctioning could result in personal injury or property loss. Anyone using this product for such applications does so at their own risk. Precision Digital Corporation shall not be held liable for damages resulting from such improper use.</i></p>

Limited Warranty

Precision Digital Corporation warrants this product against defects in material or workmanship for the specified period under "Specifications" from the date of shipment from the factory. Precision Digital's liability under this limited warranty shall not exceed the purchase value, repair, or replacement of the defective unit.

Registered Trademarks

MeterView® Pro is a registered trademark of Precision Digital Corporation. All other trademarks mentioned in this document are the property of their respective owners.

© 2018 Precision Digital Corporation. All rights reserved.

www.predig.com

Table of Contents

Table of Contents.....	3	Relay Action for Loss of 4-20 mA Input (Loop Break).....	34
Table of Figures.....	4	Relay and Alarm Operation Diagrams.....	34
Introduction.....	4	High Alarm Operation (Set > Reset).....	34
Ordering Information.....	4	Low Alarm Operation (Set < Reset).....	34
Specifications.....	5	High Alarm with Fail-Safe Operation (Set > Reset).....	35
General.....	5	Low Alarm with Fail-Safe Operation (Set < Reset).....	35
Process Input.....	5	Pump Alternation Control Operation.....	35
Relays.....	6	Relay Sampling Operation.....	36
Isolated 4-20 mA Transmitter Output.....	6	Signal Loss or Loop Break Relay Operation.....	36
RS485 Serial Communications Terminal.....	6	Time Delay Operation.....	36
Modbus® RTU Serial Communications.....	6	Relay Operation Details.....	37
Digital Input & Output Terminal.....	7	Overview.....	37
Compliance Information.....	7	Relays Auto Initialization.....	37
Safety.....	7	Fail-Safe Operation.....	37
Safety Information.....	8	Front Panel LEDs.....	37
Installation.....	8	Latching and Non-Latching Relay Operation.....	38
Unpacking.....	8	Non-Latching Relay (R _{ULTA}).....	38
Wall Mounting Instructions.....	9	Non-Latching Relay (R _{NR RN}).....	38
Mounting Dimensions.....	9	Latching Relay (L _{RLEH}).....	38
Pipe Mounting Instructions.....	10	Latching Relay (L _{LELR}).....	38
Transmitter Supply Voltage Selection (P+, P-).....	11	Acknowledging Relays.....	39
Connections.....	11	Pump Alternation Control Applications (R _{LLErn}).....	39
Connectors Labeling.....	12	Setting up the Interlock Relay (Force On) Feature.....	41
Power Connections.....	12	Scaling the 4-20 mA Analog Output (R _{OUT}).....	42
Signal Connections.....	13	Reset Menu (r _{ESEt}).....	42
Modbus RTU Serial Communications.....	14	Control Menu (C _{ONTRL}).....	42
Relay Connections.....	14	Setting up the Password (P _{RS5}).....	43
Switching Inductive Loads.....	15	Protecting or Locking the Meter.....	43
RS485 Output Connections.....	16	Making Changes to a Password Protected Meter.....	44
Digital I/O Connections.....	18	Disabling Password Protection.....	44
F4 Digital Input Connections.....	18	Advanced Features Menu.....	45
4-20 mA Output Connections.....	19	Advanced Features Menu & Display Messages.....	45
Analog Output Transmitter Power Supply.....	19	Noise Filter (F _{ILTEr}).....	47
Interlock Relay Feature.....	19	Noise Filter Bypass (b _{YP_{RS5}}).....	47
Setup and Programming.....	20	Rounding Feature (r _{OUND}).....	47
Overview.....	20	Modbus RTU Serial Communications (S _{ER} _{RL}).....	48
Programming Buttons and Status LED Indicators.....	21	Select Menu (S _{EL} _{ECT}).....	49
MeterView® Pro Software.....	22	Signal Input Conditioning (F _{UNCTn}).....	49
MeterView Pro Installation.....	22	Low-Flow Cutoff (L _{UTOFF}).....	51
Display Functions & Messages.....	23	Analog Output Programming (R _{OUTPr}).....	51
Main Menu.....	25	Programmable Function Keys User Menu (u _{SER}).....	51
Setting Numeric Values.....	25	Tare (t _{ARE}).....	52
Setting up the Meter (S _{ETUP}).....	26	Internal Source Calibration (i _{LR_L}).....	53
Setting the Input Signal (i _{nPUT}).....	27	Meter Operation.....	54
Setting the Input Units or Custom Tags (u _n _{t5}).....	27	Button Operation.....	54
Setting the Decimal Point (d _{EC} _{Pt}).....	28	Function Key Operation.....	54
Programming the Meter (P _{ROG}).....	28	Digital Input Operation.....	54
Setting the Display Parameter & Intensity (d _{SP_{LR}}).....	31	Maximum/Minimum Readings.....	55
Setting the Relay Operation (r _{ELRY}).....	32	Troubleshooting.....	55
Setting the Relay Action.....	33	Diagnostics Menu (d _{IRG}).....	55
Programming Set and Reset Points.....	33	Determining Software Version.....	56
Setting Fail-Safe Operation.....	33	Reset Meter to Factory Defaults.....	56
Programming Time Delay.....	33	Factory Defaults & User Settings.....	57
		Troubleshooting Tips.....	58

Table of Figures

Figure 1. Meter Mounting Holes	9	Figure 13. AC and DC Loads Protection	15
Figure 2. Meter Dimensions - Side View	9	Figure 14. Low Voltage DC Loads Protection.....	15
Figure 3. Meter Dimensions – Front View	9	Figure 15. RS-422 or RS-485 Wiring.....	16
Figure 4. Vertical Pipe Mount Assembly	10	Figure 16. RS-485 Two-Wire Multi-Drop Wiring	17
Figure 5. Horizontal Pipe Mount Assembly	10	Figure 17. Connections for RS485 Connector to Serial Converter.....	17
Figure 6. Transmitter Supply Voltage Selection	11	Figure 18. Three-Wire RS485 Connection	18
Figure 7. Connector Labeling for Fully Loaded PD2-6001	12	Figure 19. Digital Input and Output Connections.....	18
Figure 8. Power Connections.....	12	Figure 20. F4 Digital Input Connections	18
Figure 9. Transmitters Powered by Internal Supply	13	Figure 21. 4-20 mA Output Connections	19
Figure 10. Transmitter Powered by Ext. Supply or Self- Powered.....	13	Figure 22. Interlock Connections.....	19
Figure 11. Voltage Input Connections	14	Figure 23. Acknowledge Relays w/Function Key or Digital Input	39
Figure 12. Relay Connections.....	14		

Introduction

The Helios PD2-6001 is a multi-purpose, easy to use, large-display digital process meter featuring a bright, easy-to-read main display with large 1.8 inch superluminous LED digits which can be read from up to 100 feet away and convenient feet and inches designations. It is housed in a water-resistant, field mountable NEMA 4X/IP65 rated enclosure for convenient indoor or outdoor installation.

The meter accepts current and voltage signals (e.g. 4-20 mA, 0-10 V). Three of the programming buttons can be set for custom operation. The analog input can be scaled to display the process in two different scales; for example, the main display could indicate level in feet and the second display could indicate the volume in gallons.

A fully loaded Helios PD2-6001 meter comes with four (4) SPDT relays, a 4 20 mA output, two 24 VDC power supplies, five (5) digital inputs and four (4) digital outputs, and RS485 serial communications.

The four relays can be used for alarm indication or process control applications such as pump alternation control. The 4-20 mA isolated output, Modbus RTU serial communications, and digital I/O features make the Helios an excellent addition to any system.

Ordering Information

Standard Models

85-265 VAC Model	12-24 VDC Model	Options Installed
PD2-6001-6H0	PD2-6001-7H0	No Options
PD2-6001-6H7	PD2-6001-7H7	4 relays & 4-20 mA output

Accessories

Model	Description
PDA6260	Pipe Mounting Kit
PDA7485-I	RS-232 to RS-422/485 isolated converter
PDA7485-N	RS-232 to RS-422/485 non-isolated converter
PDA8485-I	USB to RS-422/485 isolated converter
PDA8485-N	USB to RS-422/485 non-isolated converter
PDAPLUG2	Plastic Conduit Plug
PDX6901	Suppressor (snubber): 0.01 μ F/470 Ω , 250 VAC

Specifications

Except where noted all specifications apply to operation at +25°C.

General

Display	Main display: 1.8" (46 mm) high, red LEDs separated by feet and inches labels 6 digits per line (-99999 to 999999), with lead zero blanking
Display Intensity	Eight user selectable intensity levels
Display Update Rate	5/second (200 ms)
Overrange	Display flashes 999999
Underrange	Display flashes -99999
Display Assignment	Line 1 and line 2 may be assigned to PV1, PV2, PCT, d r-u, d gross, d nt-g, max/min, max & min, set points, units (line 2 only), or Modbus input.
Programming Methods	Four programming buttons, digital inputs, PC and MeterView Pro software, or Modbus registers.
Noise Filter	Programmable from 2 to 199 (0 will disable filter)
Filter Bypass	Programmable from 0.1 to 99.9% of calibrated span
Recalibration	All ranges are calibrated at the factory. Recalibration is recommended at least every 12 months.
Max/Min Display	Max/min readings reached by the process are stored until reset by the user or until power to the meter is turned off.
Password	Three programmable passwords restrict modification of programmed settings. Pass 1: Allows use of function keys and digital inputs Pass 2: Allows use of function keys, digital inputs and editing set/reset points Pass 3: Restricts all programming, function keys, and digital inputs.
Power Options	85-265 VAC 50/60 Hz, 90-265 VDC, 20 W max or 12-24 VDC \pm 10%, 15 W max Powered over USB for configuration only.
Isolated Transmitter Power Supply	Terminals P+ & P-: 24 VDC \pm 10%. 12-24 VDC powered models selectable for 24, 10, or 5 VDC supply (internal P+/P- switch). 85-265 VAC models rated @ 200 mA max, 12-24 VDC powered models rated @ 100 mA max, @ 50 mA max for 5 or 10 VDC supply.
Non-Volatile Memory	All programmed settings are stored in non-volatile memory for a minimum of ten years if power is lost.
Fuse	Required external fuse: UL Recognized, 5 A max, slow blow; up to 6 meters may share one 5 A fuse
Normal Mode Rejection	Greater than 60 dB at 50/60 Hz

Isolation	4 kV input/output-to-power line 500 V input-to-output or output-to-P+ supply
Overvoltage Category	Installation Overvoltage Category II: Local level with smaller transient overvoltages than Installation Overvoltage Category III.
Environmental	Operating temperature range: -40 to 150°F (-40 to 65°C) Storage temperature range: -40 to 185°F (-40 to 85°C) Relative humidity: 0 to 90% non-condensing
Connections	Removable and integrated screw terminal blocks accept 12 to 22 AWG wire, RJ45 for external serial communication adapters.
Enclosure	UL Type 4X, IP65 rated. Polycarbonate & glass blended plastic case, color: gray. Includes four PG11 through-hole conduit openings, with two factory installed PG11, IP68, black nylon threaded hole plugs with backing nuts.
Mounting	Wall Mounting: Four (4) mounting holes provided for screwing meter into wall. See Wall Mounting Instructions on page 9 for additional details. Pipe Mounting: Optional pipe mounting kit (PDA6260) allows for pipe mounting. Sold separately. See Pipe Mounting Instructions on page 10 for additional details.
Tightening Torque	Removable Screw Terminals: 5 lb-in (0.56 Nm) Digital I/O and RS485 Terminals: 2.2 lb-in (0.25 Nm)
Overall Dimensions	10.63" x 12.59" x 4.77" (270 mm x 319.7 mm x 121.2 mm) (W x H x D)
Weight	6.10 lbs (2.76 kg)
Warranty	3 years parts & labor
Process Input	
Inputs	Field selectable: 0-20, 4-20 mA, \pm 10 V (0-5, 1-5, 0-10 V), Modbus PV (Slave)
Accuracy	\pm 0.03% of calibrated span \pm 1 count, square root & programmable exponent accuracy range: 10-100% of calibrated span
Temperature Drift	0.005% of calibrated span/°C max from 0 to 65°C ambient, 0.01% of calibrated span/°C max from -40 to 0°C ambient
Signal Input Conditioning	Linear, square root, programmable exponent, or round horizontal tank volume calculation
Multi-Point Linearization	2 to 32 points for PV or PV1 2 to 8 points for PV2 (Dual-scale Level feature)

Programmable Exponent	1.0001 to 2.9999	
Round H Tank	Diameter & Length: 999.999 inch or cm calculates volume in gallons or liters respectively.	
Low-Flow Cutoff	0-999999 (0 disables cutoff function)	
Decimal Point	Up to five decimal places or none: <i>d. dddddd, d. dddd, d. ddd, d. dd, d. d, or ddddd</i>	
Calibration Range	Input Range	Minimum Span Input 1 & Input 2
	4-20 mA ±10 V An error message will appear if the input 1 and input 2 signals are too close together.	0.15 mA 0.01 V
Input Impedance	Voltage ranges: greater than 500 kΩ Current ranges: 50 - 100 Ω (depending on resettable fuse impedance)	
Input Overload	Current input protected by resettable fuse, 30 VDC max. Fuse resets automatically after fault is removed.	
F4 Digital Input Contacts	3.3 VDC on contact. Connect normally open contacts across F4 to COM.	
F4 Digital Input Logic Levels	Logic High: 3 to 5 VDC Logic Low: 0 to 1.25 VDC	

Relays

Rating	4 SPDT (Form C) internal rated 3 A @ 30 VDC and 125/250 VAC resistive load; 1/14 HP (≈ 50 W) @ 125/250 VAC for inductive loads
Noise Suppression	Noise suppression is recommended for each relay contact switching inductive loads; see page 15 for details.
Deadband	0-100% of span, user programmable
High Or Low Alarm	User may program any alarm for high or low trip point. Unused alarm LEDs and relays may be disabled (turn off).
Relay Operation	Automatic (non-latching) and/or manual reset Latching (requires manual acknowledge) with/without clear Pump alternation control (2 to 4 relays) Sampling (based on time) Off (disable unused relays and enable Interlock feature) Manual on/off control mode
Time Delay	0 to 999.9 seconds, on & off relay time delays Programmable and independent for each relay
Fail-Safe Operation	Programmable and independent for each relay. <i>Note: Relay coil is energized in non-alarm condition. In case of power failure, relay will go to alarm state.</i>
Auto Initialization	When power is applied to the meter, relays will reflect the state of the input to the meter.

Relay Reset	User selectable via front panel buttons or digital inputs
	<ol style="list-style-type: none"> Automatic reset only (non-latching), when the input passes the reset point. Automatic + manual reset at any time (non-latching) Manual reset only, at any time (latching) Manual reset only after alarm condition has cleared (latching) <p><i>Note: Front panel button or digital input may be assigned to acknowledge relays programmed for manual reset.</i></p>

Isolated 4-20 mA Transmitter Output

Output Source	Process variable (PV), max, min, set points 1-5, Modbus input, or manual control mode
Scaling Range	1.000 to 23.000 mA for any display range
Calibration	Factory calibrated: 4.000 to 20.000 = 4-20 mA output
Analog Out Programming	23.000 mA maximum for all parameters: Overrange, underrange, max, min, and break
Accuracy	± 0.1% of span ± 0.004 mA
Temperature Drift	0.4 µA/°C max from 0 to 65°C ambient, 0.8 µA/°C max from -40 to 0°C ambient <i>Note: Analog output drift is separate from input drift.</i>
Isolated Transmitter Power Supply	Terminals I+ & R: 24 VDC ± 10%. May be used to power the 4-20 mA output or other devices. Refer to Figure 21 on page 19. All models rated @ 40 mA max.
External Loop Power Supply	35 VDC maximum
Output Loop Resistance	Power supply Minimum Maximum
	24 VDC 10 Ω 700 Ω
	35 VDC 100 Ω 1200 Ω (external)

RS485 Serial Communications Terminal

Compatibility	EIA-485
Connectors	Removable screw terminal connector
Max Distance	3,937' (1,200 m) max
Status Indication	Separate LEDs for Power (P), Transmit (TX), and Receive (RX)

Modbus® RTU Serial Communications

Slave Id	1 – 247 (Meter address)
Baud Rate	300 – 19,200 bps
Transmit Time Delay	Programmable between 0 and 199 ms
Data	8 bit (1 start bit, 1 or 2 stop bits)
Parity	Even, Odd, or None with 1 or 2 stop bits
Byte-To-Byte Timeout	0.01 – 2.54 second
Turn Around Delay	Less than 2 ms (fixed)

Note: Refer to the Modbus Register Tables located at www.predig.com for details.

Digital Input & Output Terminal

Channels	4 digital inputs & 4 digital outputs
Digital Input Logic High	3 to 5 VDC
Digital Input Logic Low	0 to 1.25 VDC
Digital Output Logic High	3.1 to 3.3 VDC
Digital Output Logic Low	0 to 0.4 VDC

Source Current	10 mA maximum output current
Sink Current	1.5 mA minimum input current
	To be used as pull-up for digital inputs only. Connect normally open pushbuttons across +5 V & DI 1-4.
+5 V Terminal	<div style="border: 1px solid black; padding: 5px; display: inline-block;">  WARNING! </div> <p><i>DO NOT use +5 V terminal to power external devices.</i></p>

Compliance Information

Safety

UL & C-UL Listed	USA & Canada UL 508 Industrial Control Equipment (United States), C22.2 No. 142 (Canadian National Standard)
UL File Number	E160849
Front Panel	UL Type 4X, NEMA 4X, IP65
Low Voltage Directive	EN 61010-1:2010 Safety requirements for measurement, control, and laboratory use

Safety Information

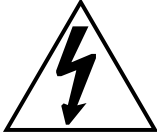
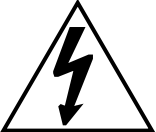
	
<p>Caution: <i>Read complete instructions prior to installation and operation of the meter.</i></p>	<p>Warning: <i>Risk of electric shock or personal injury.</i></p>
 Warning!	<p>Hazardous voltages exist within enclosure. Installation and service should be performed only by trained service personnel.</p>

Installation

There is no need to open the clear plastic front cover in order to complete the installation, wiring, and setup of the meter. All programming is done through the buttons and switches located under the lower door panel and are accessible by removing the single securing screw. Wires should be run through the knockout holes located on the bottom of the meter.

There are a total of four pre-drilled conduit entry holes located at the bottom of the meter. If the need to drill additional holes arises, make sure you will have the clearance necessary for conduit mounting hardware.

Do not disconnect the RJ45 connector found on the right side of the meter wiring board. Doing so will disable the onboard digital I/O, RS-485 serial communications, and M-Link functionality.

Instructions are provided for changing the transmitter power supply to output 5 or 10 VDC instead of 24 VDC, see page 10.

Unpacking

Remove the meter from box. Inspect the packaging and contents for damage. Report damages, if any, to the carrier. If any part is missing or the meter malfunctions, please contact your supplier or the factory for assistance.

Wall Mounting Instructions

The meter can be mounted to any wall using the four provided mounting holes. Note that the bottom mounting holes are located underneath the front door panel. To mount the meter to a wall, follow these instructions.

1. Prepare a section of wall approximately 11" x 13" (280 mm x 330 mm) for meter mounting by marking with a pencil the mounting holes (shown in the image to the right) on the wall.
2. Using a drill bit slightly smaller than the girth of the mounting screws, pre-drill holes at the mounting locations previously marked.
3. Insert mounting screws into the four mounting holes and screw them into the pre-drilled holes. **Do not overtighten** the mounting screws as it is possible that the enclosure could crack and become damaged.

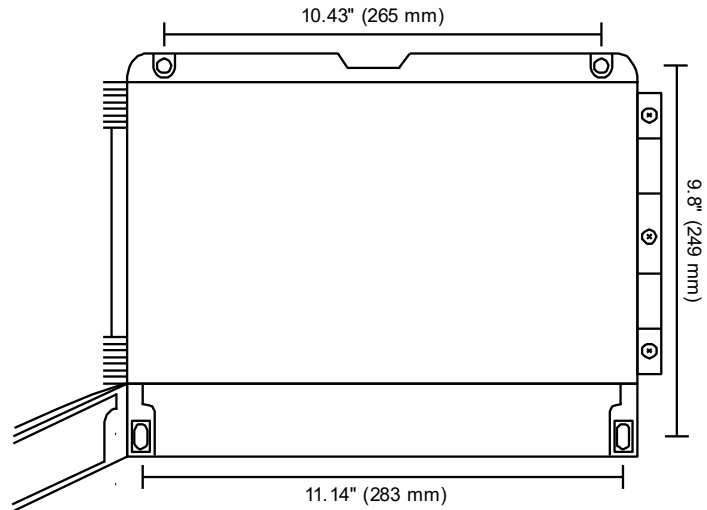

Figure 1. Meter Mounting Holes

Mounting Dimensions

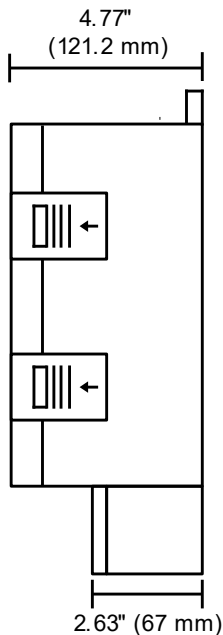

Figure 2. Meter Dimensions - Side View

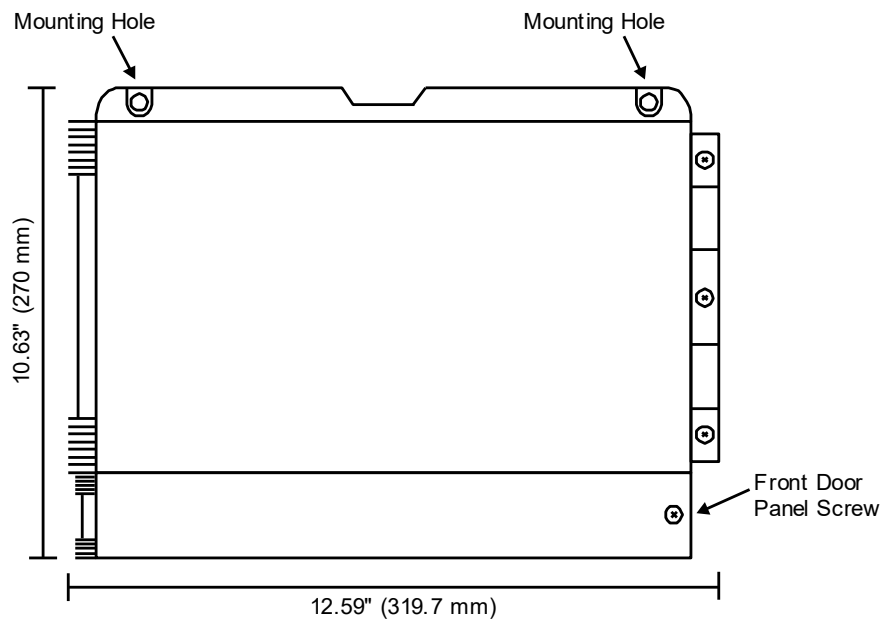

Figure 3. Meter Dimensions – Front View

Pipe Mounting Instructions

The meter can also be mounted to a pipe using the optional pipe mounting kit (PDA6260). This kit includes two mounting plates, two U-bolts, and the necessary nuts and bolts. To mount the meter to a pipe using the pipe mounting kit accessory, follow these instructions.

1. Secure the mounting plates to the top and bottom (for vertical pipes) or left and right (for horizontal pipes) of the reverse side of the meter enclosure using the provided fasteners. **Do not overtighten** the fasteners as it could cause damage to the enclosure.
2. Using the provided nuts and U-bolts, secure the mounting plates to the pipe enough torque such that the meter cannot be moved up or down (or side to side).

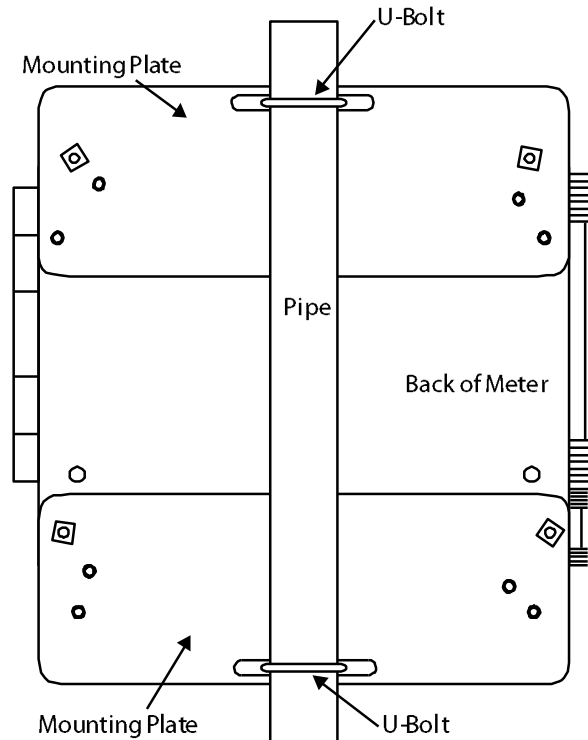

Figure 4. Vertical Pipe Mount Assembly

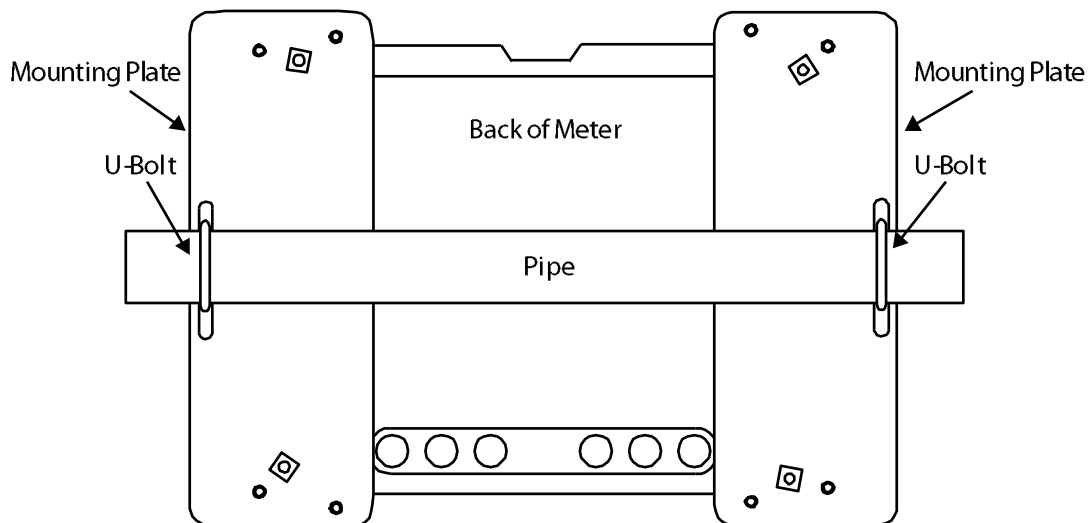

Figure 5. Horizontal Pipe Mount Assembly

Transmitter Supply Voltage Selection (P+, P-)

All meters, including models equipped with the 12-24 VDC power option, are shipped from the factory configured to provide 24 VDC power for the transmitter or sensor.

If the transmitter requires 5 or 10 VDC excitation, the switch labeled P+/P- must be configured accordingly.

To access the voltage selection jumper:

1. Unplug the meter power.
2. Unscrew and open the front door panel.
3. Locate the P+/P- switch located in the center of the connections board (see diagram below).
4. Flip this switch into the appropriate position for the required transmitter excitation.

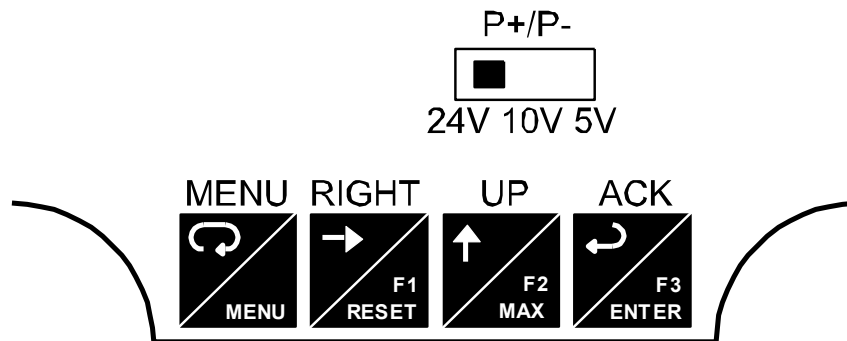



Figure 6. Transmitter Supply Voltage Selection

Connections

All connections are made to screw terminal connectors located under the front door panel. Remove the single securing screw in order to access the wiring terminals.

 Caution	<p><i>Use copper wire with 60°C or 60/75°C insulation for all line voltage connections. Observe all safety regulations. Electrical wiring should be performed in accordance with all applicable national, state, and local codes to prevent damage to the meter and ensure personnel safety.</i></p>
---	--

Connectors Labeling

The connectors' label, affixed to the inside of the lower door panel, shows the location of all connectors available with requested configuration.

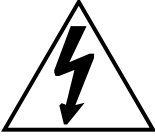
 Warning!	<p>Do not connect any equipment other than Precision Digital's expansion modules, cables, or meters to the RJ45 M-LINK connector. Otherwise damage will occur to the equipment and the meter.</p> <p>Do not disconnect the RJ45 connector located to the left of the power terminal block. Doing so will disable the onboard digital I/O, RS-485 serial communications, and M-Link functionality.</p>
--	---

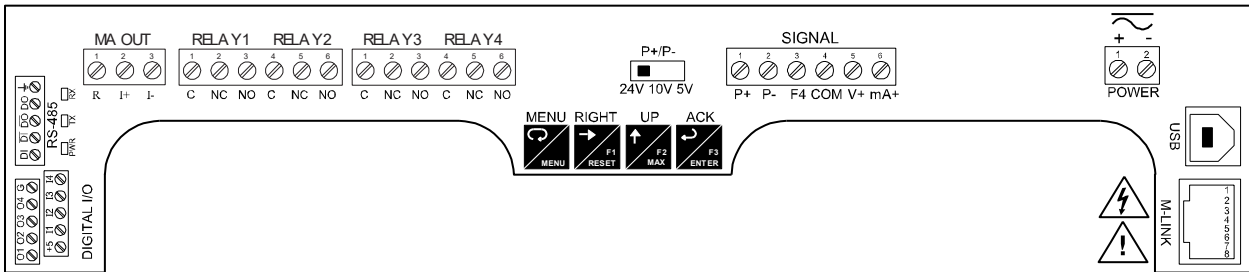

Figure 7. Connector Labeling for Fully Loaded PD2-6001

Power Connections

Power connections are made to a two-terminal connector labeled POWER on Figure 7 on page 12. The meter will operate regardless of DC polarity connection. The + and - symbols are only a suggested wiring convention.

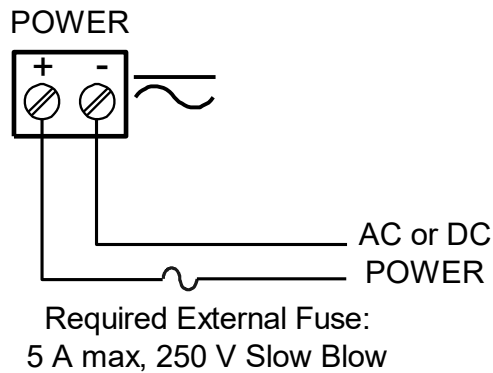

Figure 8. Power Connections

Signal Connections

Signal connections are made to a six-terminal connector labeled SIGNAL on Figure 7. The COM (common) terminal is the return for the 4-20 mA and the ± 10 V input signals.

Current and Voltage Connections

The following figures show examples of current and voltage connections.

There are no switches or jumpers to set up for current and voltage inputs. Setup and programming is performed through the front panel buttons.

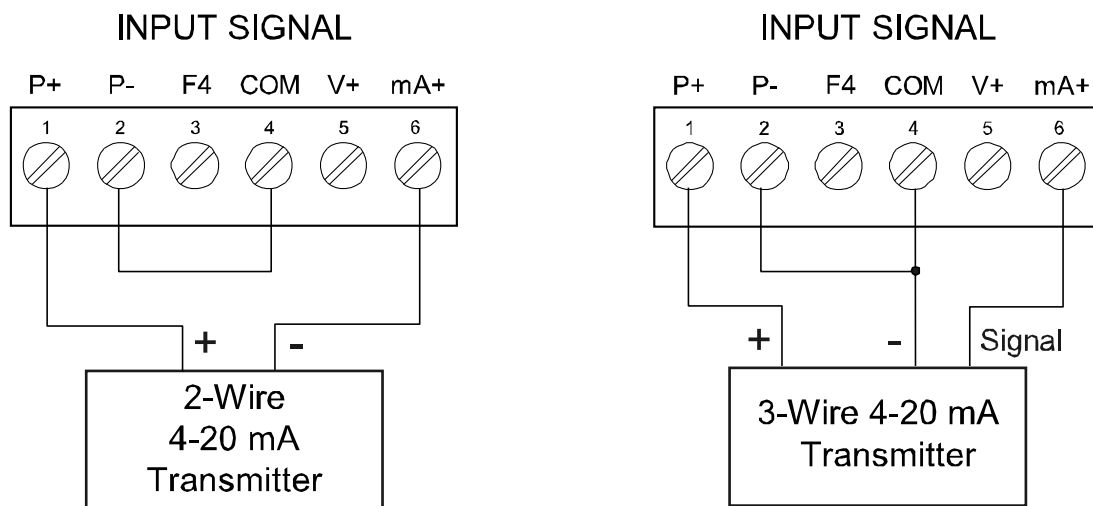

Figure 9. Transmitters Powered by Internal Supply

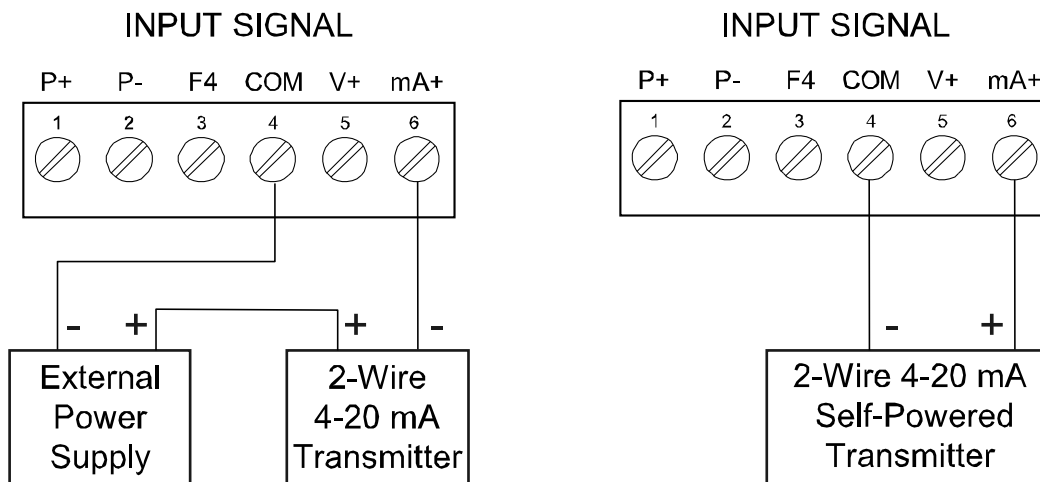

Figure 10. Transmitter Powered by Ext. Supply or Self-Powered

The current input is protected against current overload by a resettable fuse. The display may or may not show a fault condition depending on the nature of the overload.

The fuse limits the current to a safe level when it detects a fault condition, and automatically resets itself when the fault condition is removed.

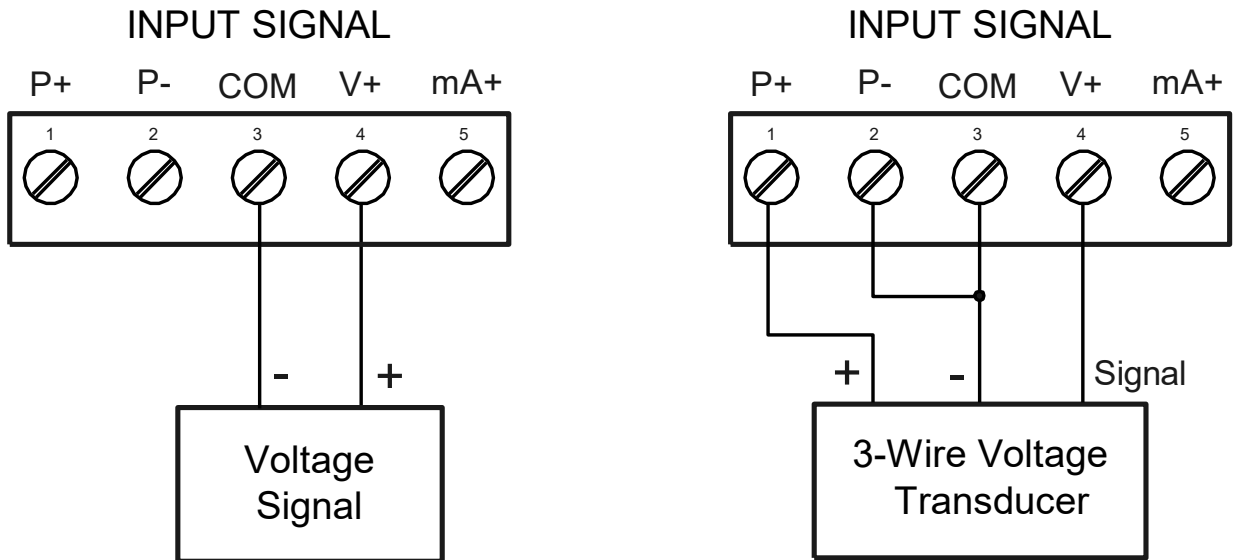

Figure 11. Voltage Input Connections

The meter is capable of accepting any voltage from -10 VDC to +10 VDC.

Modbus RTU Serial Communications

Serial communications connection can be made to the onboard RS485 terminal block or USB connector shown in Figure 7. If RS232 is required, an RS485 to RS232 adapter (PDA7485) may be used. See Ordering Information on page 4 for additional information.

Relay Connections

Relay connections are made to two six-terminal connectors labeled RELAY1 – RELAY4 on Figure 7. Each relay's C terminal is common only to the normally open (NO) and normally closed (NC) contacts of the corresponding relay. The relays' C terminals should not be confused with the COM (common) terminal of the INPUT SIGNAL connector.

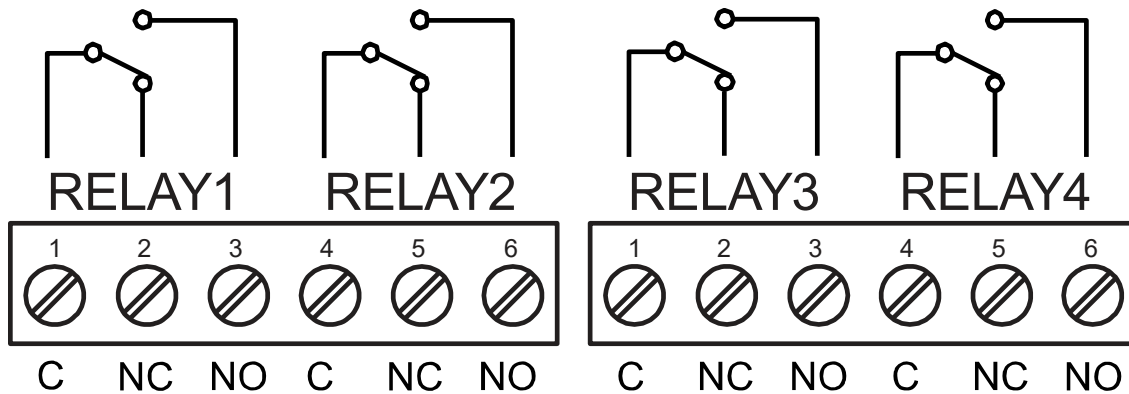

Figure 12. Relay Connections

Switching Inductive Loads

The use of suppressors (snubbers) is strongly recommended when switching inductive loads to prevent disrupting the microprocessor's operation. The suppressors also prolong the life of the relay contacts. Suppression can be obtained with resistor-capacitor (RC) networks assembled by the user or purchased as complete assemblies. Refer to the following circuits for RC network assembly and installation:

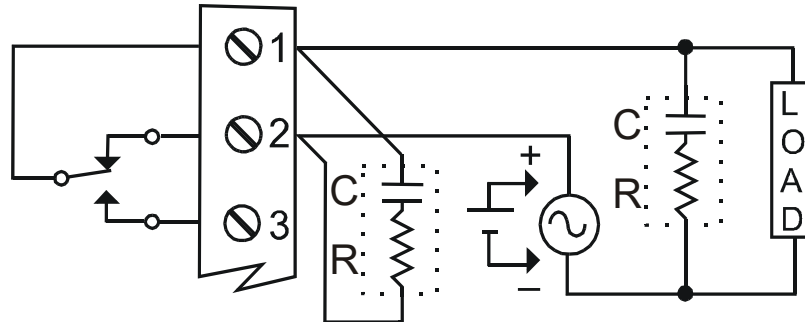

Figure 13. AC and DC Loads Protection

Choose R and C as follows:

R: 0.5 to 1 Ω for each volt across the contacts

C: 0.5 to 1 μF for each amp through closed contacts

Notes:

1. Use capacitors rated for 250 VAC.
2. RC networks may affect load release time of solenoid loads. Check to confirm proper operation.
3. Install the RC network at the meter's relay screw terminals. An RC network may also be installed across the load. Experiment for best results.

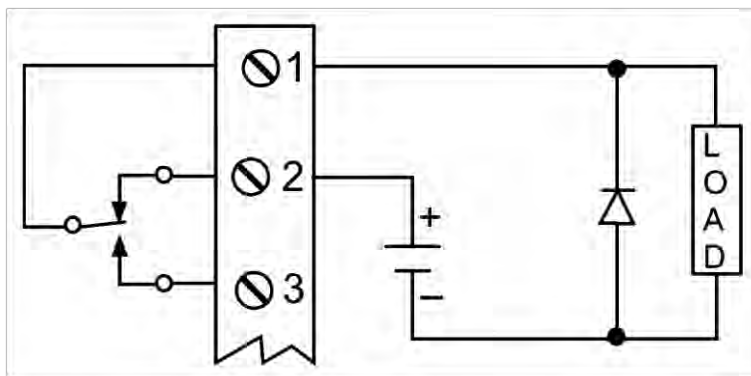

Figure 14. Low Voltage DC Loads Protection

RC Networks Available from Precision Digital

RC networks are available from Precision Digital and should be applied to each relay contact switching an inductive load. Part number: PDX6901.

Note: Relays are de-rated to 1/14th HP (50 watts) with an inductive load.

Use a diode with a reverse breakdown voltage two to three times the circuit voltage and forward current at least as large as the load current.

RS485 Output Connections

An RS-485 connector is provided for the use of advanced Modbus® serial communications. This connector converts the serial output of the meter to balanced, full or half-duplex RS-485 signals. It has a removable screw terminal connector for the RS-485 terminals which includes Transmit Data (DO) and (/DO), Receive Data (DI) and (/DI), and Signal Ground. Baud rates are adjustable and handled by the meter (see Modbus RTU Serial Communications on page 48 for more information).

The RS-485 connector has three diagnostic LEDs: a Power (PWR) LED to show when the adapter is powered properly, a Transmit Data (TX) LED to show when the adapter is sending data out from the PC side, and a Receive Data (RX) LED to show when the adapter is receiving data from the meter.

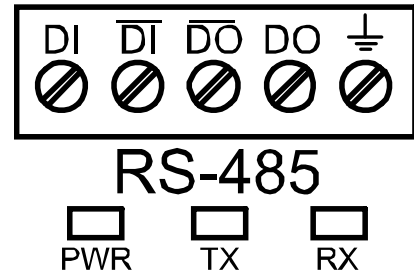

Installation

Figure 15 shows the connection of a meter to a PC using the RS485 output connector and a PDA7485 RS-232 to RS-422/485 converter in an RS-422 network. Figure 16 shows the connection of several meters to a PC using a PDA7485 RS-232 to RS-422/485 converter in an RS-485 network.

When using more than one meter in a multi-drop mode, each meter must be provided with its own unique address. The meter address (Slave ID) may be programmed between 1 and 247. The transmit delay may be set between 0 and 199 ms. The parity can be set to even, odd, or none with 1 or 2 stop bits.

To change the meter address:

1. Press and hold the **Menu** button for three seconds to access *Advanced Features* menu of the meter.
2. Press **Up** arrow until Serial (*SErIAL*) menu is displayed and press **Enter**, *Addr-E5* is displayed.
3. Press **Enter** to change meter address using **Right** and **Up** arrow buttons. Press **Enter** to accept.
4. Press **Menu** button to exit and return to Run Mode.

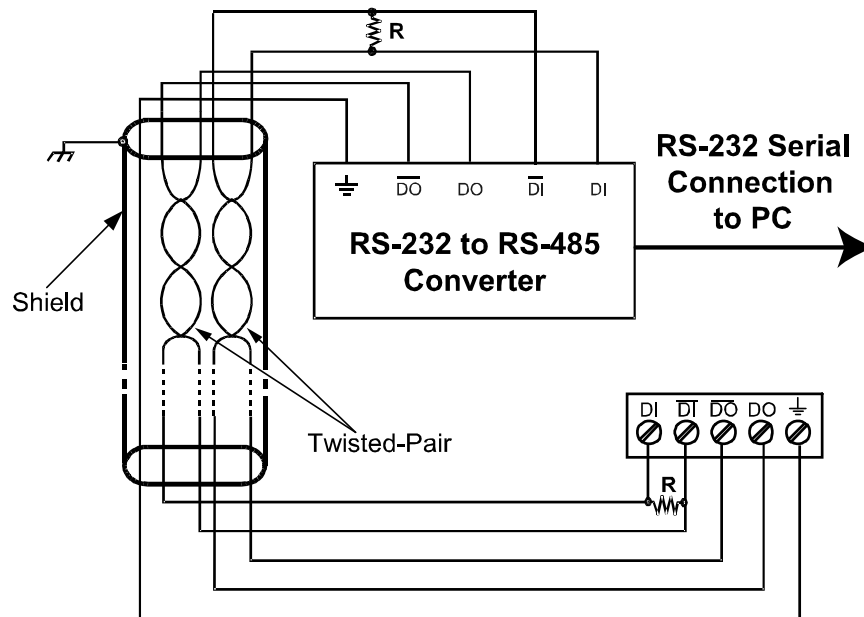

Figure 15. RS-422 or RS-485 Wiring

Notes:

1. Termination resistors are optional and values depend on the cable length and characteristic impedance. Consult the cable manufacturer for recommendations.
2. Refer to RS-232 to RS-422/485 Converter documentation for further details.

- Use shielded cable, twisted-pairs plus ground. Connect ground shield only at one location.

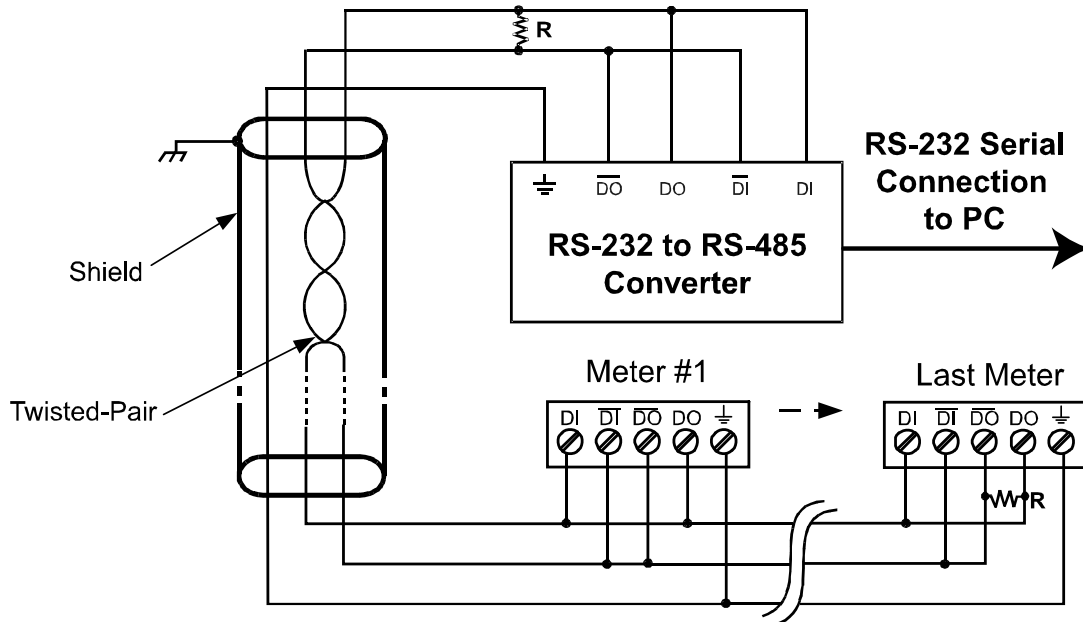

Figure 16. RS-485 Two-Wire Multi-Drop Wiring

Notes:

- Termination resistors are optional and values depend on the cable length and characteristic impedance. Consult the cable manufacturer for recommendations.
- Refer to RS-232 to RS-485 Converter documentation for further details.
- Use shielded cable, twisted-pair plus ground. Connect ground shield only at one location.

Connections

Figure 17 details the wiring connections from the RS-485 connector to an RS-422/485 serial converter (such as the PDA7485 or PDA8485) for a four-wire network.

RS485 Connector to RS-422/485 Serial Converter Connections	
RS-422/485 Serial Converter	PDA1485 RS-485 Adapter
⏏	⏏
DO̅	DI
DO	DI
DI̅	DO̅
DI	DO

Figure 17. Connections for RS485 Connector to Serial Converter

Three Wire Connection

In order to wire the 5 pins for use as a 3-wire half-duplex RS-485 connection, it is necessary to create a jumper connection between DI – DO and DI- – DO- as shown below.

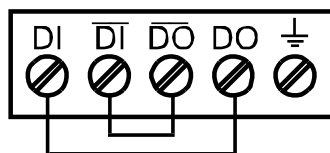

Figure 18. Three-Wire RS485 Connection

Digital I/O Connections

Digital inputs and outputs are provided in order to expand the functionality of the meter. Digital inputs are made via a push button or switch connection to the appropriate digital input connector block and the +5 VDC block. Digital output connections are made by wiring from the appropriate digital output block to the grounding terminal block.

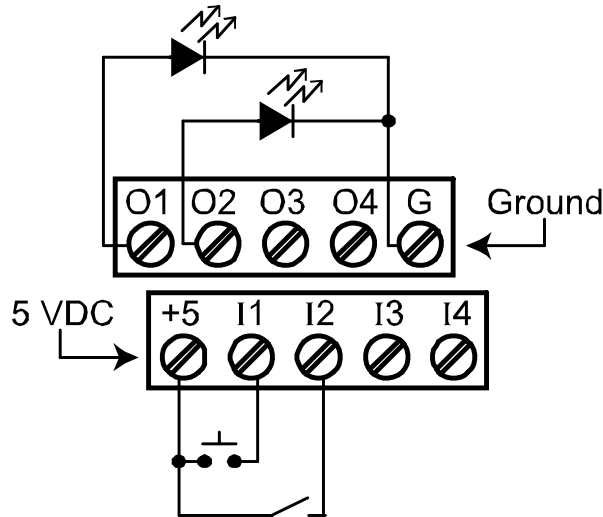

Figure 19. Digital Input and Output Connections

F4 Digital Input Connections

Digital input F4 is also available on the meter. This digital input is connected with a normally open contact across F4 and COM, or with an active low signal applied to F4.

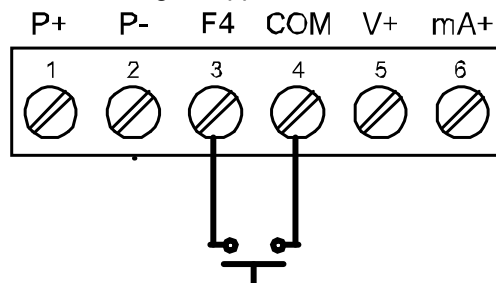

Figure 20. F4 Digital Input Connections

4-20 mA Output Connections

Connections for the 4-20 mA transmitter output are made to the connector terminals labeled MA OUT. The 4-20 mA output may be powered internally or from an external power supply.

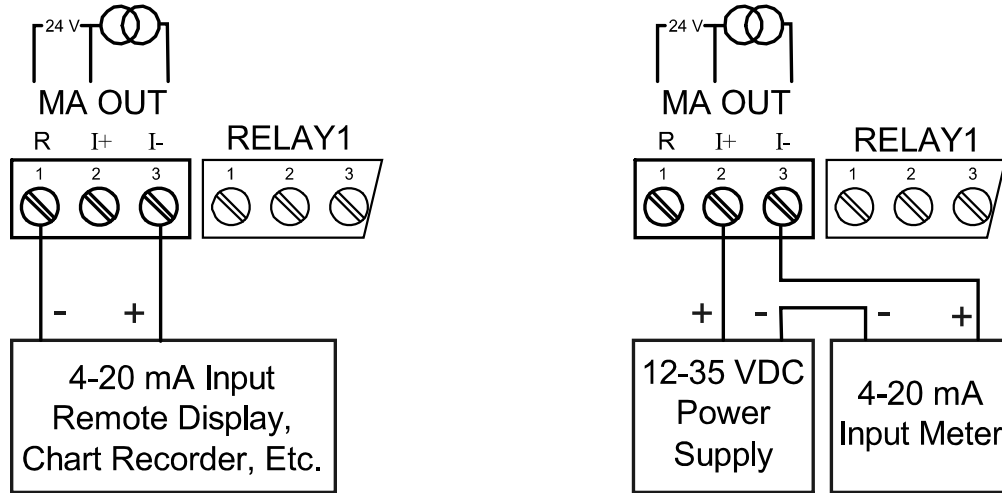

Figure 21. 4-20 mA Output Connections

Analog Output Transmitter Power Supply

The internal 24 VDC power supply powering the analog output may be used to power other devices, if the analog output is not used. The I+ terminal is the +24 V and the R terminal is the return.

Interlock Relay Feature

As the name implies, the interlock relay feature reassigns one, or more, alarm/control relays for use as interlock relay(s). Interlock contact(s) are wired to digital input(s) and trigger the interlock relay. This feature is enabled by configuring the relay, and relative digital input(s) (see page 41). In one example, dry interlock contacts are connected in series to one digital input which will be used to force on (energize) the assigned interlock power relay when all interlock contacts are closed (safe). The interlock relay front panel LED flashes when locked out. The interlock relay would be wired in-series with the load (N/O contact). See below.

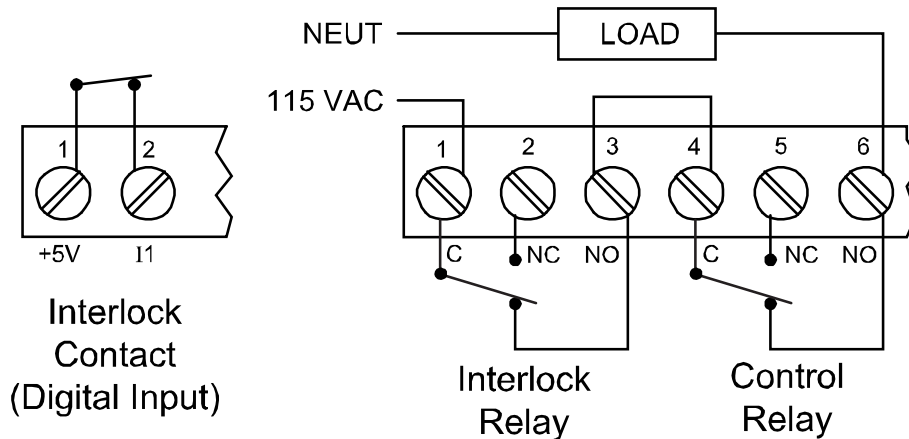

Figure 22. Interlock Connections

Setup and Programming

The meter is factory calibrated prior to shipment to read in milliamps and volts depending on the input selection. The calibration equipment is certified to NIST standards.

Overview

There are no jumpers to set for the meter input selection.

Setup and programming is done through the programming buttons located under the front door panel.

After power and input signal connections have been completed and verified, apply power to the meter.



Programming Buttons and Status LED Indicators

The meter can be programmed using the buttons located behind the front door panel. Use the *Menu* button to enter or exit *Programming Mode*, the *Up Arrow* button to cycle through menu options, and the *Enter* button to select the menu item or option you want. The *Right Arrow* button is used during numeric and decimal point programming.

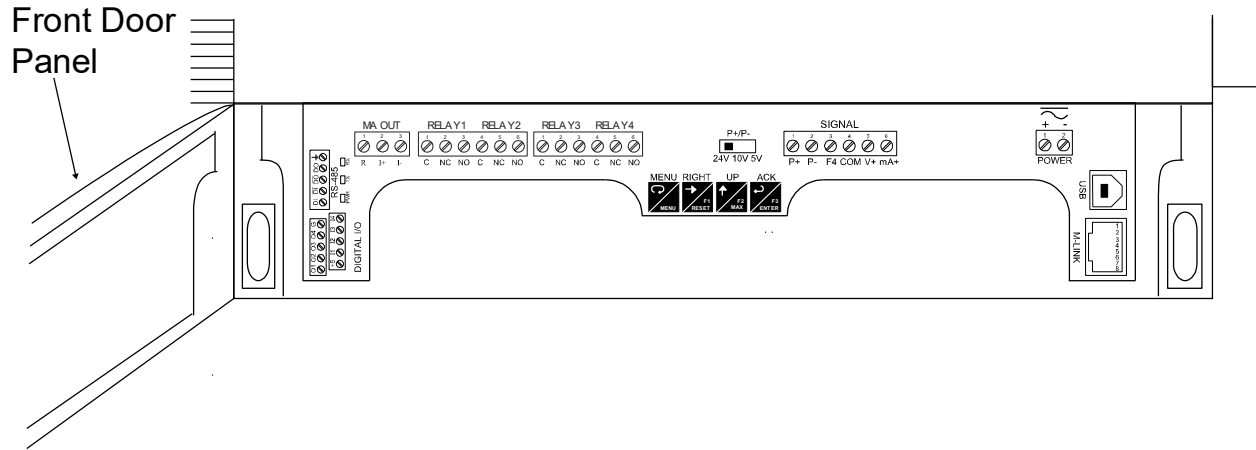

Button Symbol	Description	LED	Status
FT IN - -	Feet and inches designation separators	8 16	Fractions of an inch indicator (eighths or sixteenths)
	Menu	1-4	Alarm 1-4 indicator
	Right arrow/F1	1-4 M	Flashing: Relay in manual control mode
	Up arrow/F2	T	Flashing: Tare
	Acknowledge (Enter)/F3	1-4	Flashing: Relay interlock switch open
Note: F4 – F8 are digital inputs.		Note: LEDs for relays in manual mode flash with the “M” LED every 10 seconds. “M” flashing by itself indicates Aout – manual control is used.	

- Press the **Menu** button to enter or exit the Programming Mode at any time.
- Press the **Right Arrow** button to move to the next digit during digit or decimal point programming.
- Press the **Up Arrow** button to scroll through the menus, decimal point, or to increment a digit.
- Press the **Enter** button to access a menu or to accept a setting.
- Press and hold the **Menu** button for three seconds to access the advanced features of the meter.

MeterView® Pro Software

The meter can also be programmed using the PC-based MeterView Pro software included with the meter. This software can be installed on any Microsoft® Windows® (2000/XP/Vista/7/8/10) computer by connecting the meter's onboard USB. The meter is powered by the USB connection, so there is no need to wire anything prior to programming the meter, though USB is intended only for meter configuration.

MeterView Pro Installation

1. Connect one end of the provided USB cable to the meter and the other end to the computer. The computer will automatically install the driver software it needs to talk to the meter.
Only one meter may be connected at a time. Attaching multiple meters will cause a conflict with the meter software. Disconnect other meters before performing these steps.

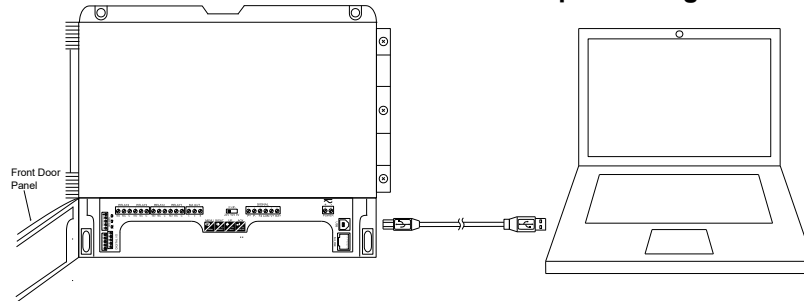

2. Once the driver is installed, an AutoPlay dialog should appear for the drive "MAINSTAL." Click "Open folder to view files." If the computer does not display an AutoPlay dialog for the drive "MAINSTAL," you should open My Computer and double-click on the drive labeled "MAINSTAL."
3. Double-click on the file named "MAStart." The program will open a few windows and install two programs on your computer. Simply follow the onscreen instructions until you see one of the dialogs below. If you receive a "User Account Control" warning, click "Yes."
4. If there is an update available, click the "Update" button to install the new version. Otherwise, click "Configure" to begin programming your meter.

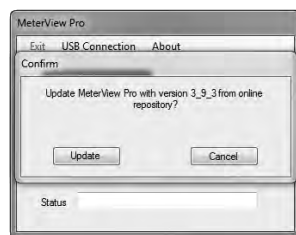

Note: If you decide to update your MeterView Pro software, once the installation has completed, you will be asked if you want to update the setup files located on the meter itself. This way, you will always have the most current version on the meter for future installs.



Do not unplug the meter while the new installation files are being written to it. The meter will display $\mu r t E$ during the process and you will receive an onscreen notification once the process is complete.

Data logging for one meter at a time is available with MeterView Pro software. More advanced data acquisition may be accomplished by using any Modbus RTU compliant software. Additional information regarding configuration and monitoring of the meter using MeterView Pro software is available online. Go to www.predig.com/meterview-pro.

Display Functions & Messages

The meter displays various functions and messages during setup, programming, and operation. The following table shows the main menu functions and messages in the order they appear in the menu.

Display	Parameter	Action/Setting Description	Display	Parameter	Action/Setting Description
SEtUP	Setup	Enter Setup menu	PRrRRr	Parameter	Press Enter to assign the Main display parameter (default: PV)
InPUt	Input	Enter Input selection menu	dSEt 1*	Display set 1*	Display relay 1 (*through 8) set point
mR	4-20 mA	Set meter for 4-20 mA input	d Hi	Display high	Display high value
VolT	0-10 VDC	Set meter for ± 10 VDC input	d Lo	Display low	Display low value
d-SCALE	Dual-scale	Press Enter to select dual-scale display for some level applications (Select Yes or No)	d HL	Display hi/low	Alternate between high/low value
unT5	Units	Select the display units/tags	mR bU5	Display Modbus	Display Modbus input register
dEc Pt	Decimal point	Set decimal point	d PV	Display PV	Select to display PV
PV 2	PV2	PV2 decimal point (Level)	L nE 2	Display Line 2	Press Enter to assign the display line 2 parameter (default: engineering units)
ProG	Program	Enter the Program menu	d unT	Display unit	Display big display channel units
SCALE	Scale	Enter the Scale menu	d PV2	Display PV2	Select to display PV2 (dual-scale display)
SCALE 1	Scale 1	Enter the Scale menu for PV1	d PCT	Display PCT	Select to display percent of PV1 (dual-scale display)
SCALE 2	Scale 2	Enter the Scale menu for PV2	d L-u	Display Level Units	Select to display PV1 level in decimal units on the little display
CAL	Calibrate	Enter the Calibration menu	d OFF	Display off	Turn off the little display
InP 1	Input 1	Calibrate input 1 signal or program input 1 value	d- InT5	Display intensity	Set display intensity level from 1 to 8
d iS 1	Display 1	Program display 1 value	rELAY	Relay	Enter the Relay menu
InP 2	Input 2	Calibrate input 2 signal or program input 2 value (up to 32 points)	rLY 1	Relay 1	Relay 1 setup
d iS 2	Display 2	Program display 2 value (up to 32 points)	Rct 1	Action 1	Set relay 1 action
Error	Error	Error, calibration not successful, check signal or programmed value	RuT0	Automatic	Set relay for automatic reset
dSPLY	Display	Enter the Display menu	R- nRRn	Auto-manual	Set relay for automatic & manual reset any time
L nE 1	Display Line 1	Press Enter to assign the display line 1 parameter (default: PV)	LRECH	Latching	Set relay for latching operation
ForRRt	Format	Format fractional inches to either eighths (1/8) or sixteenths (1/16)	Lt- Lr	Latching-cleared	Set relay for latching operation with manual reset only after alarm condition has cleared
			ALtErn	Alternate	Set relay for pump alternation control

Display	Parameter	Action/Setting Description
SRnPL	Sampling	Set relay for sampling operation
OFF	Off	Disable relay and front panel status LED (Select Off to enable Interlock feature)
SEt 1	Set 1	Program set point 1
rSE 1	Reset 1	Program reset point 1
rLY 2	Relay 2	Relays 2-4 setup
FRILSF	Fail-safe	Enter Fail-safe menu
FLS 1	Fail-safe 1	Set relay 1 fail-safe operation
on	On	Enable fail-safe operation
oFF	Off	Disable fail-safe operation
FLS 2	Fail-safe 2	Set relays 2-8 fail-safe operation
dELAY	Delay	Enter relay Time Delay menu
dLY 1	Delay 1	Enter relay 1 time delay setup
On 1	On 1	Set relay 1 On time delay
OFF 1	Off 1	Set relay 1 Off time delay
dLY 2	Delay 2	Enter relays 2-8 time delay setup
brERR	Loop break	Set relay condition if loop break detected
Ignore	Ignore	Ignore loop break condition (Processed as a low signal condition)
On	On	Relay goes to alarm condition when loop break is detected
OFF	Off	Relay goes to non-alarm condition when loop break is detected

Display	Parameter	Action/Setting Description
ANAL	Analog output	Enter the Analog output scaling menu
dIS 1	Display 1	Program display 1 value
OUT 1	Output 1	Program output 1 value (e.g. 4.000 mA)
dIS 2	Display 2	Program display 2 value
OUT 2	Output 2	Program output 2 value (e.g. 20.000 mA)
RESET	Reset	Press Enter to access the Reset menu
rSEt Hi	Reset high	Press Enter to reset max display
rSEt Lo	Reset low	Press Enter to reset min display
rSEt HL	Reset high & low	Press Enter to reset max & min displays
rSEt Tr	Reset tare	Reset tare
Control	Control	Enter Control menu
Auto	Automatic	Press Enter to set meter for automatic operation
MAN	Manual	Press Enter to manually control relays or analog output operation
PASS	Password	Enter the Password menu
PASS 1	Password 1	Set or enter Password 1
PASS 2	Password 2	Set or enter Password 2
PASS 3	Password 3	Set or enter Password 3
unLoc	Unlocked	Program password to lock meter
Locd	Locked	Enter password to unlock meter
999999 -999999	Flashing	Over/under range condition

Main Menu

The main menu consists of the most commonly used functions: *Setup*, *Reset*, *Control*, and *Password*.

- Press Menu button to enter Programming Mode then press the Up arrow button to scroll main menu.
- Press Menu, at any time, to exit and return to *Run Mode*. Changes made to settings prior to pressing Enter are not saved.
- Changes to the settings are saved to memory only after pressing Enter/F3.
- The display moves to the next menu every time a setting is accepted by pressing Enter/F3.

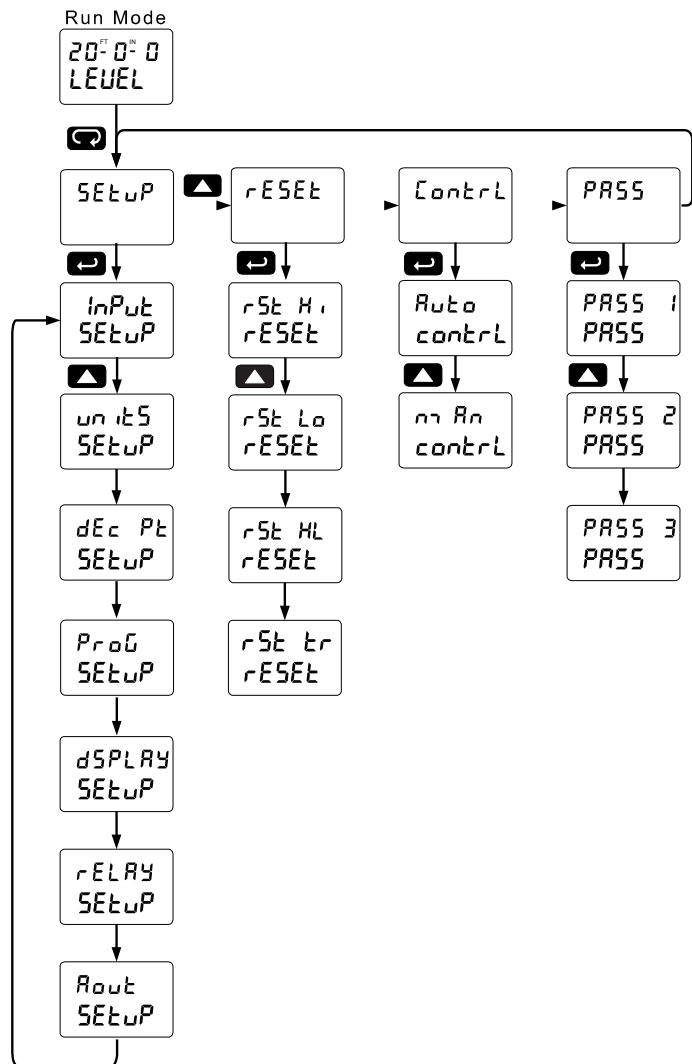

Setting Numeric Values

The numeric values on PV1 (main display) are set using the Right and Up arrow buttons. Press Right arrow to select next digit and Up arrow to increment digit value. The digit being changed is displayed brighter than the rest. The leading zero in any of the unit designations is omitted. Because of this, if the leading zero of any unit designation is the currently selected unit, none of the digits will be brighter than any other. Pressing the Up arrow will increment the value to 1.

The range of numeric values for each unit designation is from 0-99 for feet, 0-11 for inches and either 0-7 or 0-15 for fractional inches depending on whether you are in eighths ($1/8$) or sixteenths ($1/16$) mode.

Press and hold up arrow to auto-increment the display value. Press the Enter button, at any time, to accept a setting or Menu button to exit without saving changes.

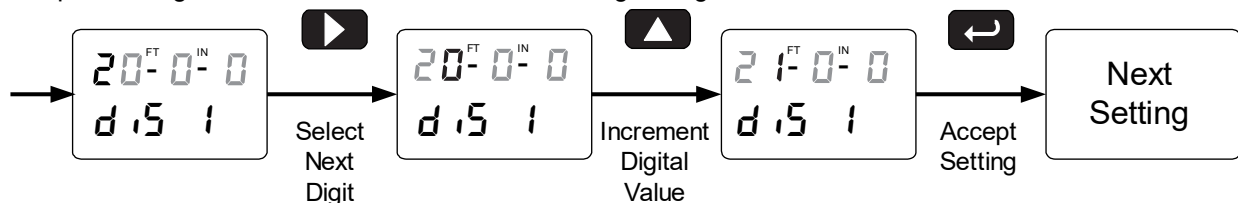

Setting up the Meter (SEtUP)

The *Setup* menu is used to select:

1. Input signal the meter will accept
2. Dual-scale feature for some level applications
3. Select the display units/tags
4. Decimal point position
5. Programming Menu
6. Display parameter and intensity
7. Relay operation
8. 4-20 mA analog output scaling

Press the *Enter* button to access any menu or press *Up* arrow button to scroll through choices. Press the *Menu* button to exit at any time.

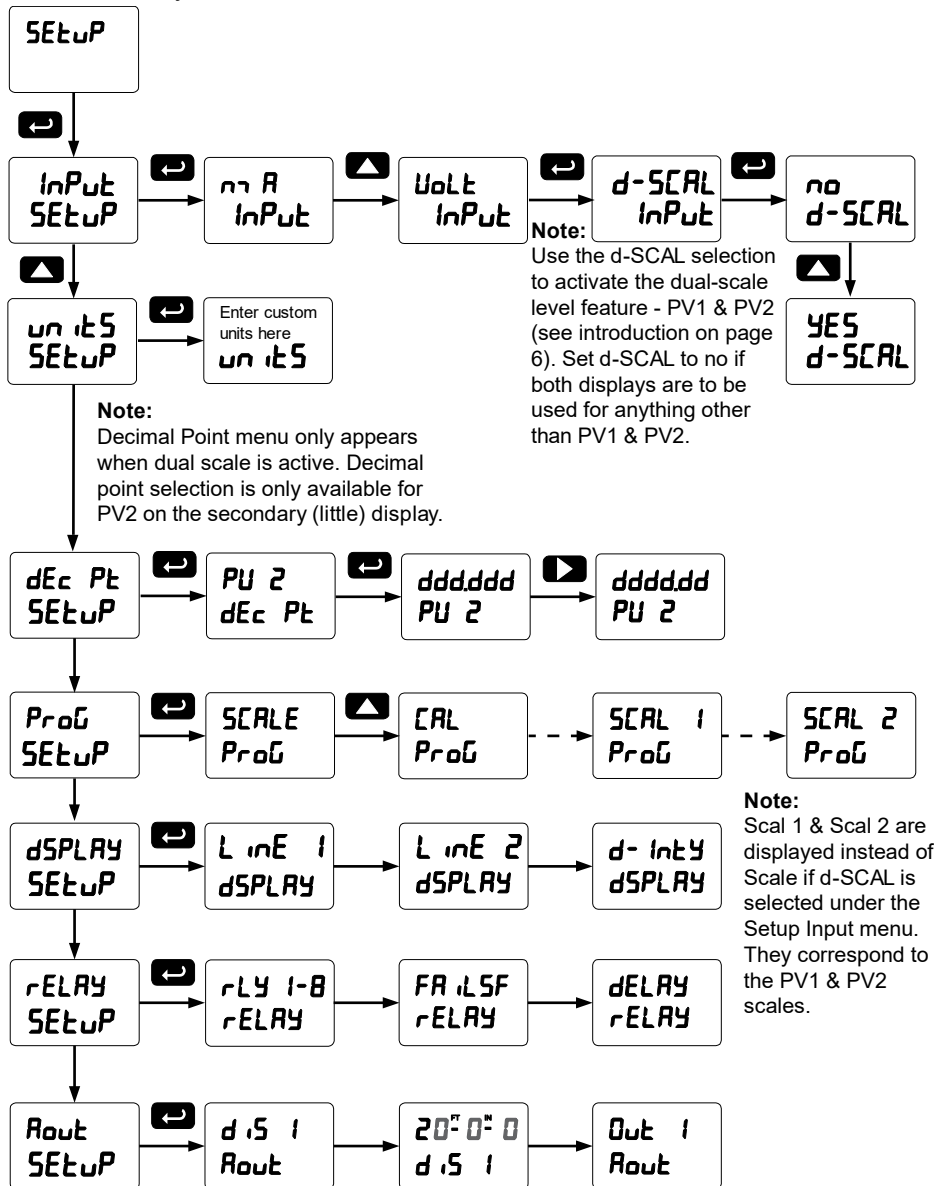

Setting the Input Signal (*inPut*)

Enter the *Input* menu to set up the meter to display current (*mA*) or voltage (*Volt*) inputs.

The current input is capable of accepting any signal from 0 to 20 mA. Select current input to accept 0-20 mA or 4-20 mA signals.

The voltage input is capable of accepting any signal from -10 to +10 VDC. Select voltage input to accept 0-5, 1-5, 0-10, or ±10 VDC signals.

After selecting *mA* or *Volt* input, *d-SCAL* is displayed; press Enter to select “Yes” or “No”. Selecting “Yes” enables the dual-scale feature, which allows for the *Scale* (*SCALE*) and *Units* (*UNIT*) menus to be used to scale the same input in two different scales for PV1 & PV2.

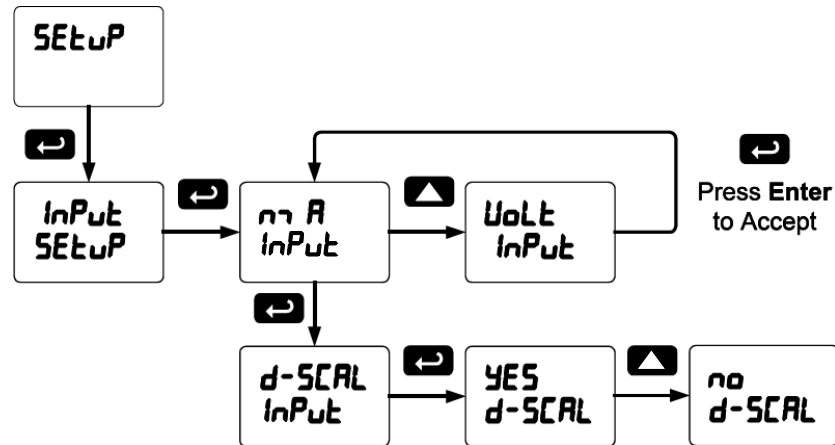

Set **d-SCAL** to no if both displays are to be used for anything other than PV1 & PV2.

Setting the Input Units or Custom Tags (*UNIT*)

Enter the input unit or custom tag that will be displayed if *d UNIT* is selected as the little display parameter. See the flow chart on page 31 to access the display menu to show the unit or tag on the little display. The engineering units or custom legends can be set using the following 7-segment character set:

Display	Character	Display	Character	Display	Character	Display	Character
0	0	C	C	H	K	U	V
1	1	c	c	L	L	w	w
2	2	d	d	m	m	X	X
3	3	E	E	n	n	Y	Y
4	4	F	F	O	O	Z	Z
5	5	G	G	o	o	-	-
6	6	g	g	P	P	/	/
7	7	H	H	q	q	[]
8	8	h	h	r	r	[[
9	9	i	i	S	S	=	=
A	A	l	l	t	t	°	Degree(<)
b	b	J	J	u	u		Space

Notes:

Degree symbol represented by (<) if programming with MeterView® Pro.

The letters “m” and “w” use two 7-segment LEDs each; when selected the characters to the right are shifted one position.

Press and hold up arrow to auto-scroll the characters in the display.

Setting the Decimal Point (dEc Pt)

The decimal point on PV2 (little display) may be set only if the dual-scale level feature is selected. It may be set with up to five decimal places or with no decimal point at all.

Pressing the Right arrow moves the decimal point one place to the right until no decimal point is displayed, and then it moves to the leftmost position. Pressing the Up arrow moves the decimal point one place to the left.

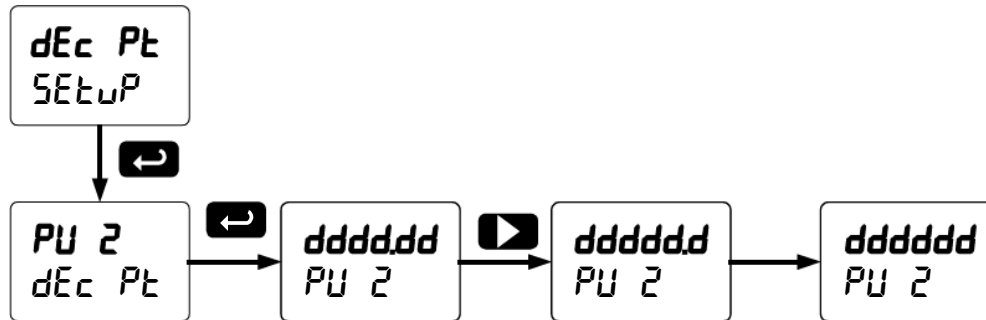

Programming the Meter (PrOG)

It is **very important** to read the following information, before proceeding to program the meter:

- The meter is factory calibrated prior to shipment to read in milliamps and volts depending on the input selection. The calibration equipment is certified to NIST standards.
- Use the *Scale* menu to scale the process input (e.g. 4-20 mA). A calibrated signal source is not needed to scale the meter.
- Use the *Calibrate* menu to apply a signal from a calibrator or a flowmeter.
- The PD6000 is a single input meter with dual-scale capability.

The *Program* menu contains the *Scale* and the *Calibrate* menus.

Note: The Scale and Calibrate functions are exclusive of each other. The meter uses the last function programmed. Only one of these methods can be employed at a time. The Scale and Calibrate functions can use up to 32 points (default is 2). The number of points should be set in the Advanced Features menu under the Multi-Point Linearization (LnERr) menu selection prior to scaling and calibration of the meter, see page 50 for details.

If the dual-scale level feature is selected in the *Setup* menu, the *Scale 1* and *Scale 2* menus are enabled for PV1 & PV2 respectively.

The process input may be calibrated or scaled to any display value within the range of the meter.

Program Menu for Single Scale Process

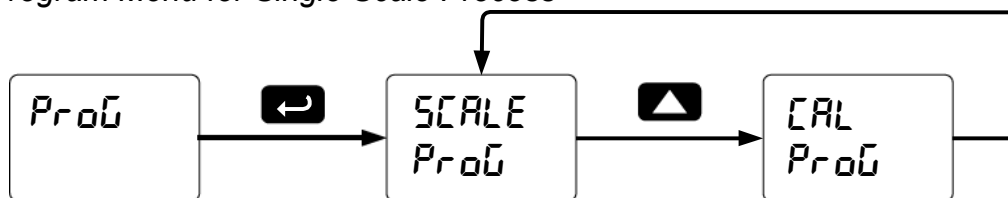

Program Menu for Dual-Scale Level Applications

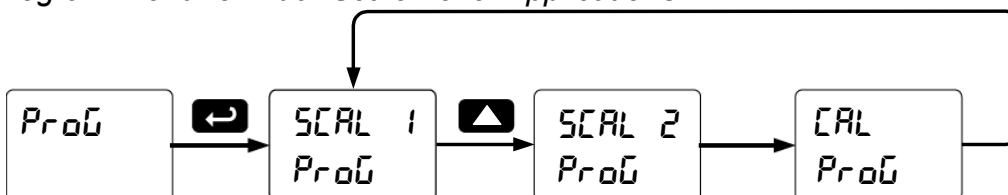

Additional parameters, not needed for most applications, are programmed in the *Advanced Features* menu; see *Advanced Features Menu*, page 45.

Multi-Point Calibration & Scaling

The meter is set up at the factory for 2-point linear calibration. The number of points for multi-point calibration/scaling is set up in the *Advanced Features* menu. Up to 32 linearization points may be selected for PV1 and up to 8 linearization points may be selected for PV2. See page 50 for details.

Scaling the Meter (SCALE)

The process input (4-20 mA, ±10 VDC) can be scaled to display the process variable in engineering units.

A signal source is not needed to scale the meter; simply program the inputs and corresponding display values.

For instructions on how to program numeric values see *Setting Numeric Values*, on page 25.

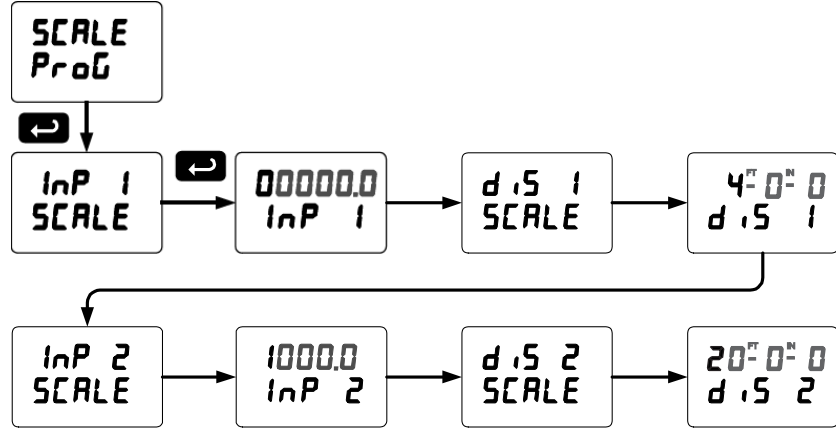

Dual-Scale for Level Application

The analog input can be displayed in two different scales, by enabling the dual-scale feature (*d-SCALE*) in the *Setup-Input* menu, see page 27.

To enable the dual-scale feature for some level applications you must select d-SCALE in the Input selection menu.

Scaling the Input for PV1 (SCALE 1)

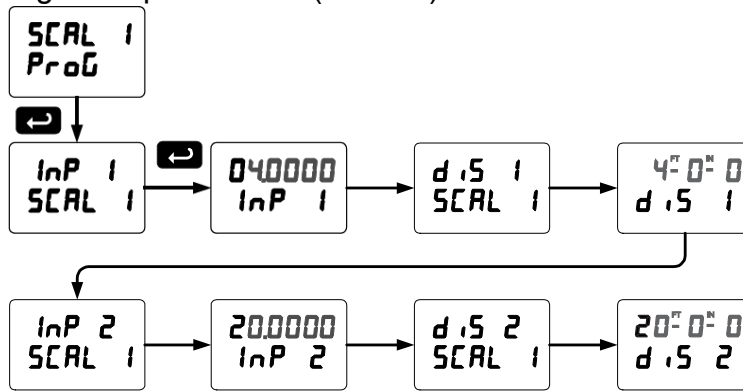

Scaling the Input for PV2 (SCALE 2)

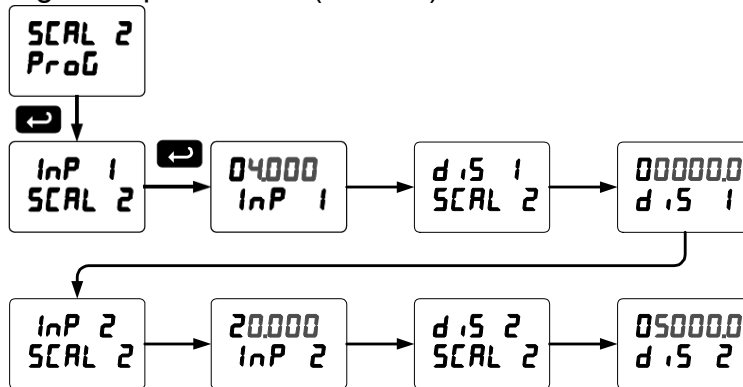

Error Message (*Error*)

An error message indicates that the calibration or scaling process was not successful.

After the error message is displayed, the meter reverts to the input prior to the failure during calibration or scaling and to input 1 during internal calibration, allowing the appropriate input signal to be applied or programmed.

The error message might be caused by any of the following conditions:

1. Input signal is not connected to the proper terminals or it is connected backwards.
2. Wrong signal selection in *Setup* menu.
3. Minimum input span requirements not maintained.
4. Input 1 signal inadvertently applied to calibrate input 2.

Minimum Input Span

The minimum input span is the minimum difference between input 1 and input 2 signals required to complete the calibration or scaling of the meter.

Input Range	Input 1 & Input 2 Span
4-20 mA	0.15 mA
±10 VDC	0.01 VDC

Calibrating the Meter with External Source (*LR*)

Note: To scale the meter without a signal source refer to Scaling the Meter (*SCALE*), page 29.

The meter can be calibrated to display the process variable in engineering units by applying the appropriate input signal and following the calibration procedure.

The use of a calibrated signal source is strongly recommended to calibrate the meter.

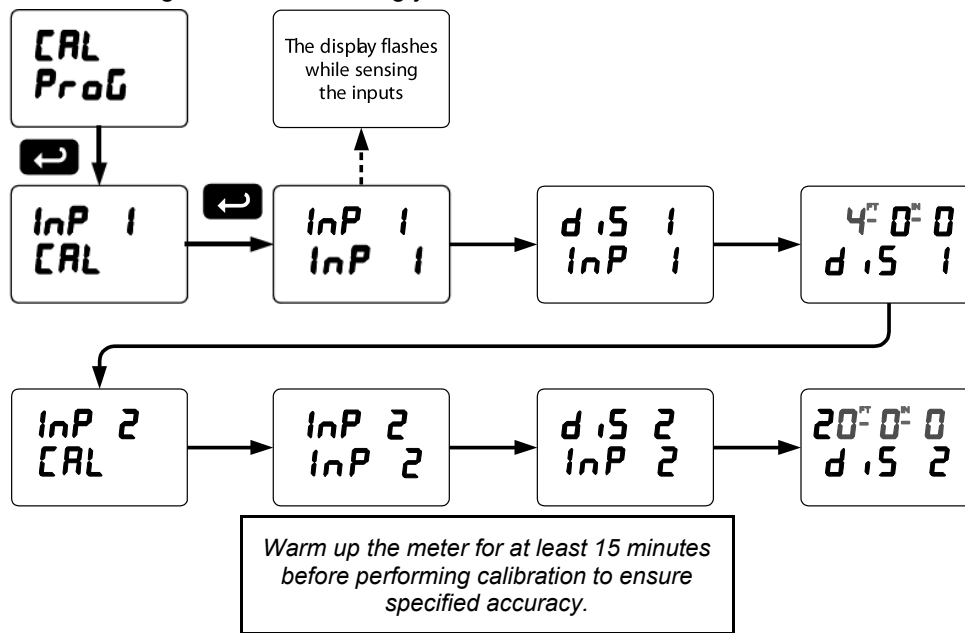

Setting the Display Parameter & Intensity (dSPRAY)

The main display (LINE 1) can be programmed to display:

1. Process value
2. Relay set points
3. Max & min values
4. Modbus input

The small display (LINE 2) can be programmed to display:

1. Unit or tag
2. Process value 2 (PV2)
3. Percent of PV1 (PCT)
4. Relay set points
5. Level value in feet with unit or tag
6. Max & min values
7. Engineering units or custom legends
8. Modbus input
9. Off (no display)

Display Intensity: The meter has eight display intensity levels to give the best performance under various lighting conditions. Select intensity 8 for outdoor applications. The default intensity setting is 8.

After setting up the input and display, press the Menu button to exit programming and skip the rest of the setup menu. Press the Menu button again and the Up arrow to reach the *Program* menu and complete the scaling or calibration of the meter.

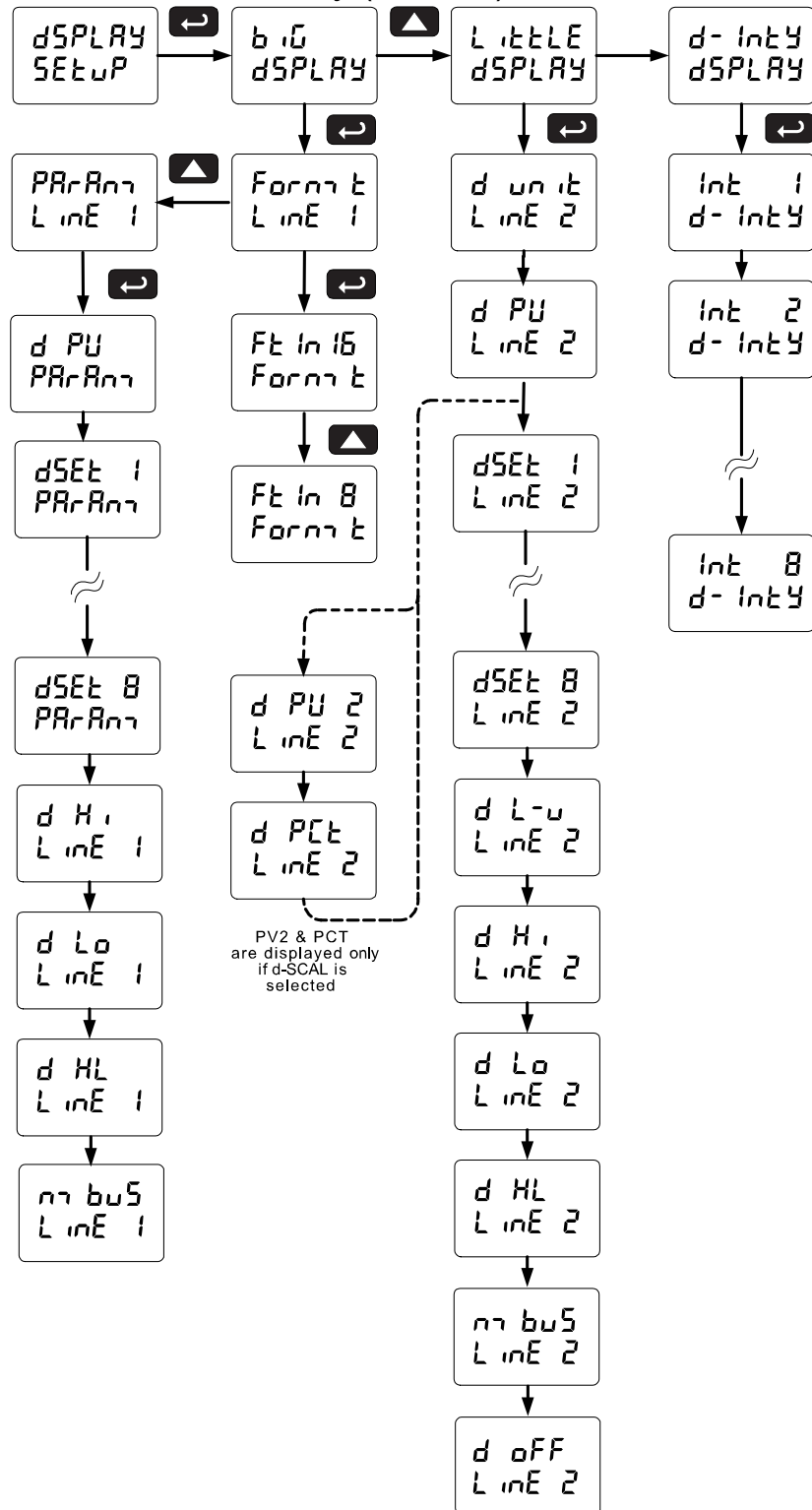

Setting the Relay Operation (rELAY)

This menu is used to set up the operation of the relays.



Caution! *During setup, the relays do not follow the input and they will remain in the state found prior to entering the Relay menu.*

1. Relay action
 - a. Automatic reset only (non-latching)
 - b. Automatic + manual reset at any time (non-latching)
 - c. Latching (manual reset only)
 - d. Latching with Clear (manual reset only after alarm condition has cleared)
 - e. Pump alternation control (automatic reset only)
 - f. Sampling (the relay is activated for a user-specified time)
 - g. Off (relay state controlled by Interlock feature)
2. Set point
3. Reset point
4. Fail-safe operation
 - a. On (enabled)
 - b. Off (disabled)
5. Time delay
 - a. On delay (0-999.9 seconds)
 - b. Off delay (0-999.9 seconds)
6. Relay action for loss (break) of 4-20 mA input (ignore, on, off)

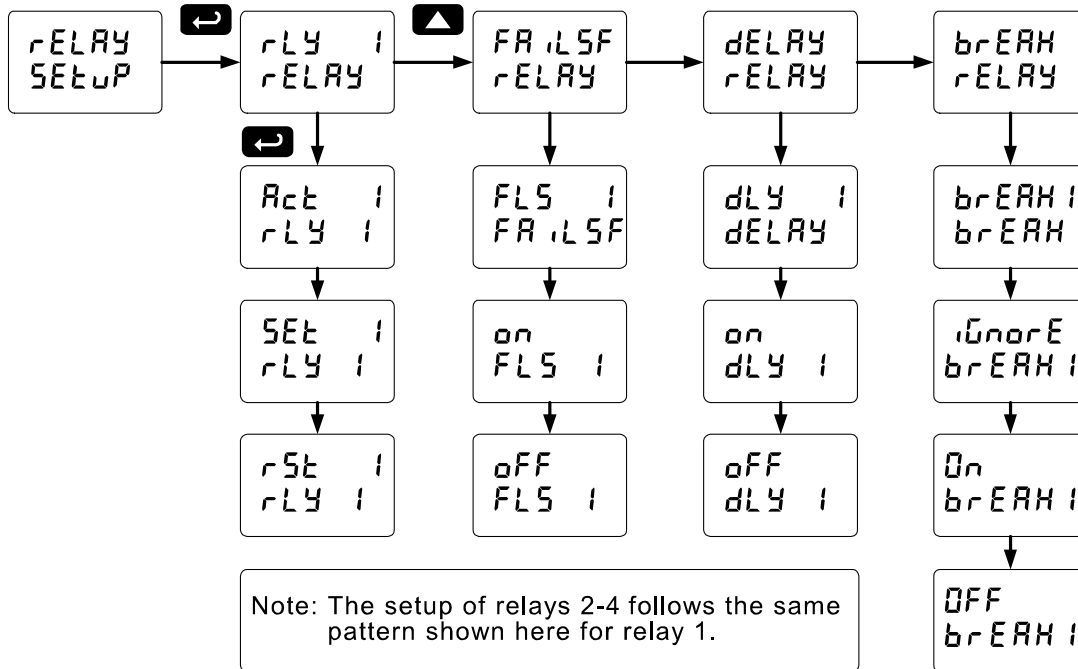

Setting the Relay Action

Operation of the relays is programmed in the *Action* menu. The relays may be set up for any of the following modes of operation:

1. Automatic reset (non-latching)
2. Automatic + manual reset at any time (non-latching)
3. Latching (manual reset only, at any time)
4. Latching with Clear (manual reset only after alarm condition has cleared)
5. Pump alternation control (automatic reset only)
6. Sampling (the relay is activated for a user-specified time)
7. Off (relay state controlled by Interlock feature)

The following graphic shows relay 1 action setup; relay 2-8 are set up in a similar fashion.

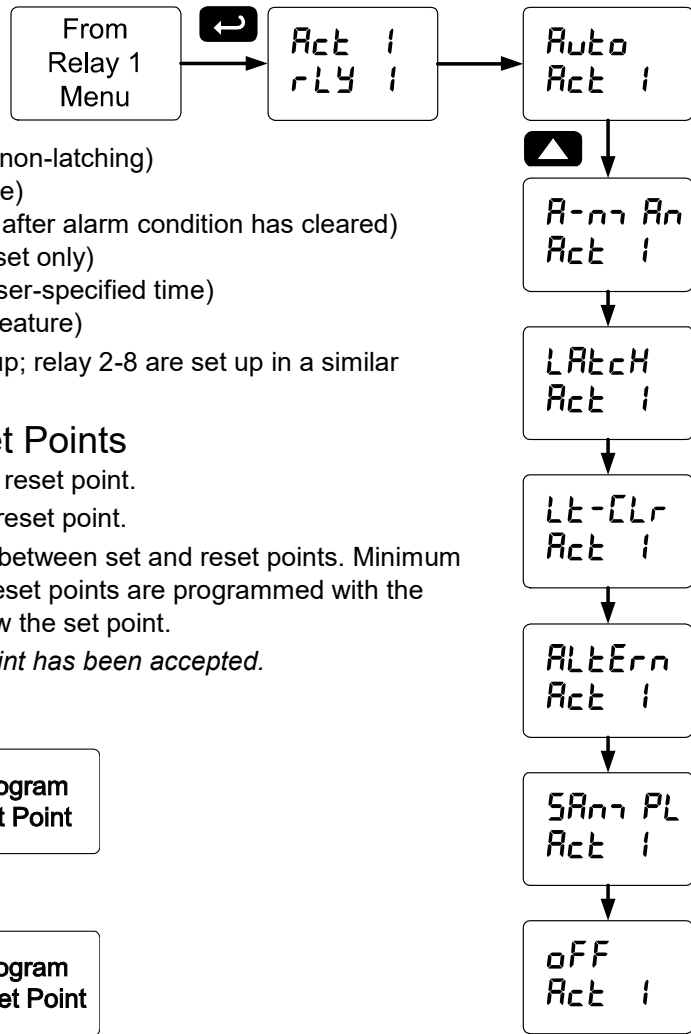

Programming Set and Reset Points

High alarm indication: program set point above reset point.

Low alarm indication: program set point below reset point.

The deadband is determined by the difference between set and reset points. Minimum deadband is one display count. If the set and reset points are programmed with the same value, the relay will reset one count below the set point.

Note: Changes are not saved until the reset point has been accepted.

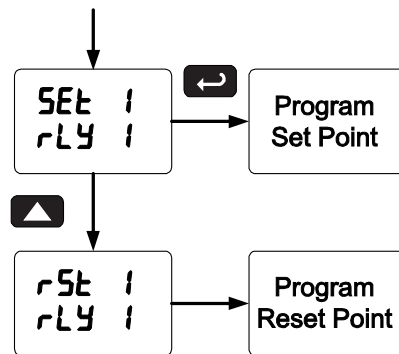

Setting Fail-Safe Operation

In fail-safe mode of operation, the relay coil is energized when the process variable is within safe limits and the relay coil is de-energized when the alarm condition exists. The fail-safe operation is set independently for each relay. Select **on** to enable or select **oFF** to disable fail-safe operation.

Programming Time Delay

The *On* and *Off* time delays may be programmed for each relay between 0 and 999.9 seconds. The relays will transfer only after the condition has been maintained for the corresponding time delay.

The *On* time delay is associated with the set point.

The *Off* time delay is associated with the reset point.

Relay Action for Loss of 4-20 mA Input (Loop Break)

The loop break feature is associated with the 4-20 mA input. Each relay may be programmed to go to one of the following conditions when the meter detects the loss of the input signal (i.e. < 0.005 mA):

1. Turn On (Go to alarm condition)
2. Turn Off (Go to non-alarm condition)
3. Ignore (Processed as a low signal condition)

Note: This is not a true loop break condition; if the signal drops below 0.005 mA, it is interpreted as a "loop break" condition.

Relay and Alarm Operation Diagrams

The following graphs illustrate the operation of the relays, status LEDs, and ACK button.

High Alarm Operation (Set > Reset)

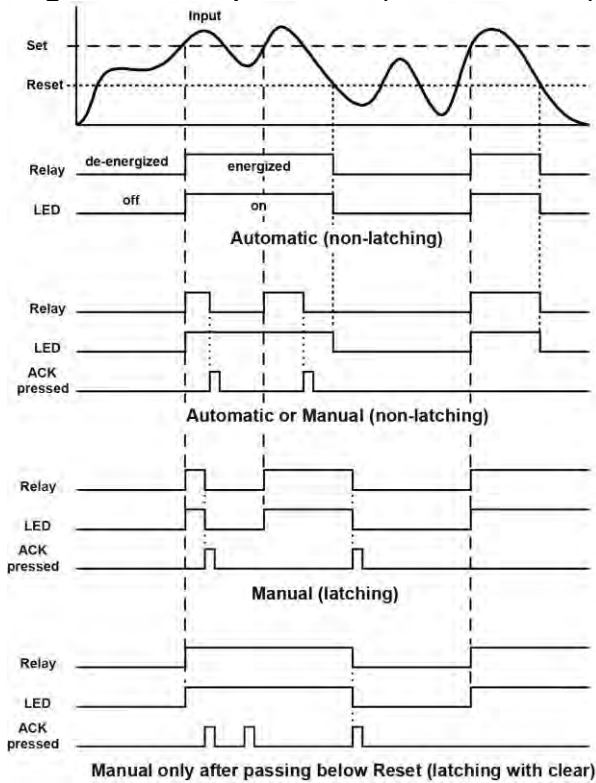

For Manual reset mode, ACK can be pressed anytime to turn "off" relay. To detect a new alarm condition, the signal must go below the set point, and then go above it.

Low Alarm Operation (Set < Reset)

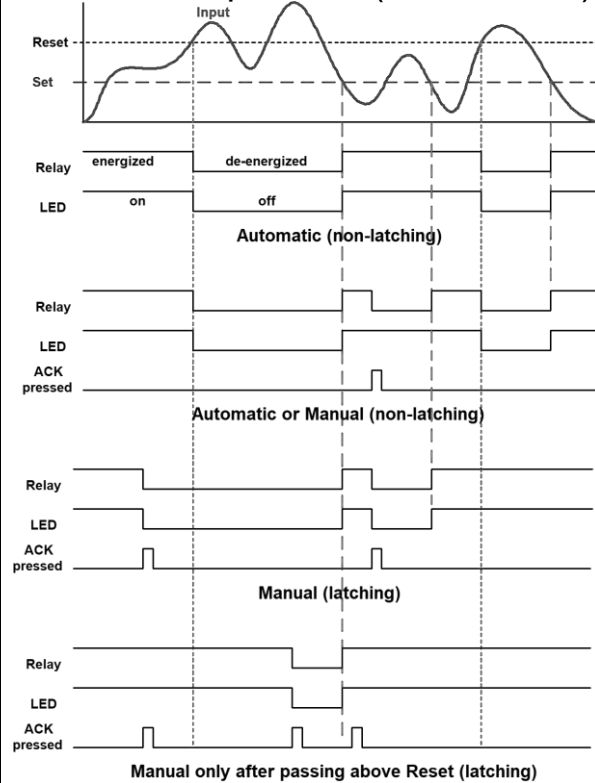

For Manual reset mode, ACK can be pressed anytime to turn "off" relay. For relay to turn back "on", signal must go above set point and then go below it.

High Alarm with Fail-Safe Operation (Set > Reset)

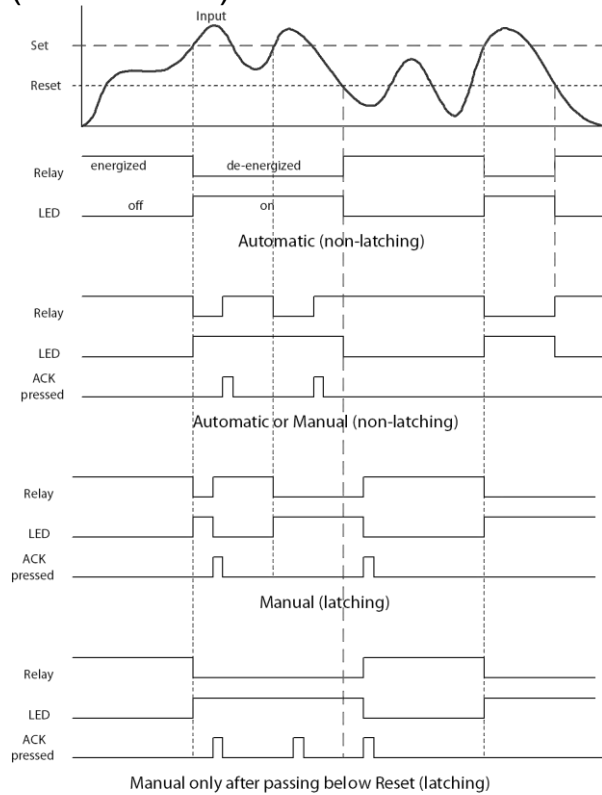

Note: Relay coil is energized in non-alarm condition. In case of power failure, relay will go to alarm state.

Low Alarm with Fail-Safe Operation (Set < Reset)

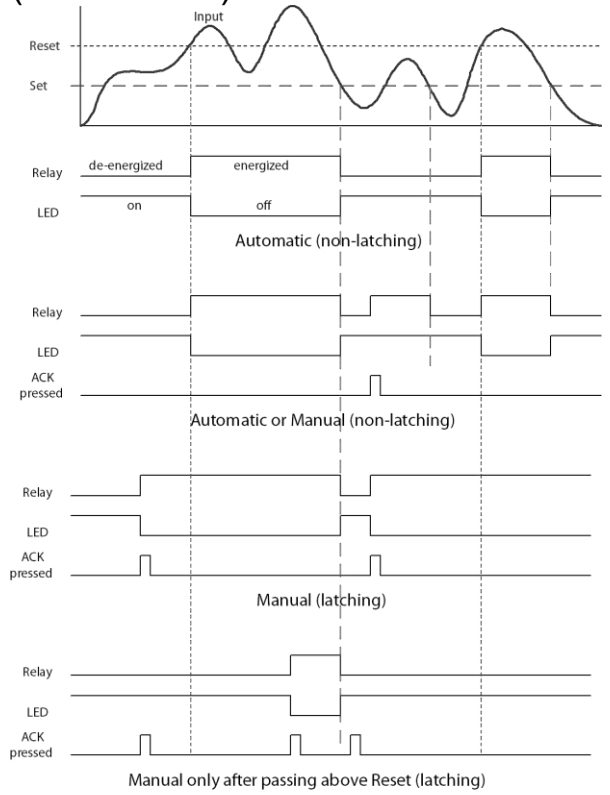

Note: Relay coil is energized in non-alarm condition. In case of power failure, relay will go to alarm state.

Pump Alternation Control Operation

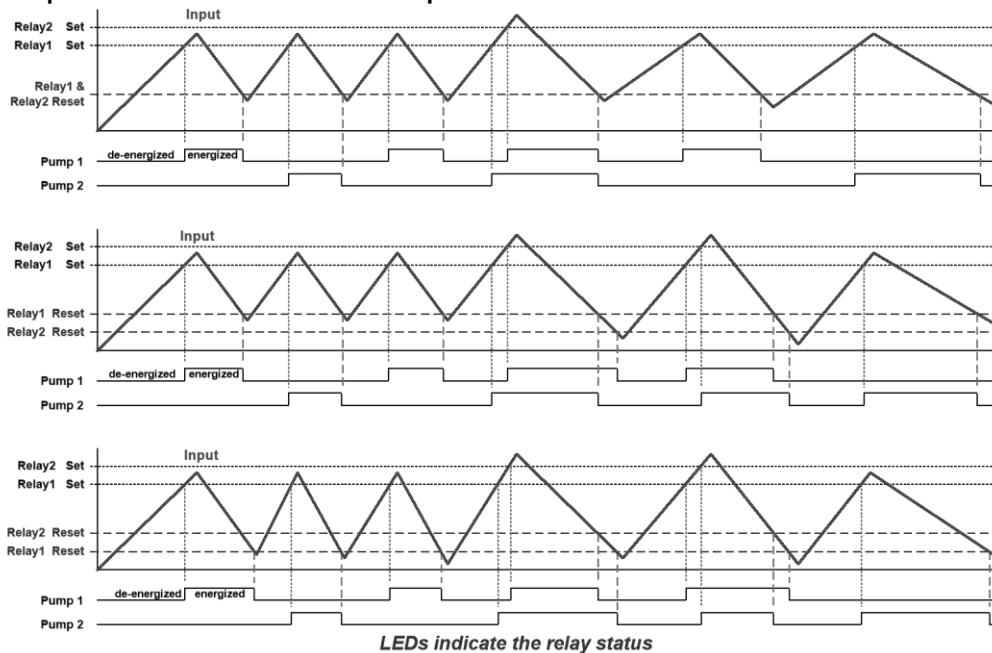

LEDs indicate the relay status

Relay Sampling Operation

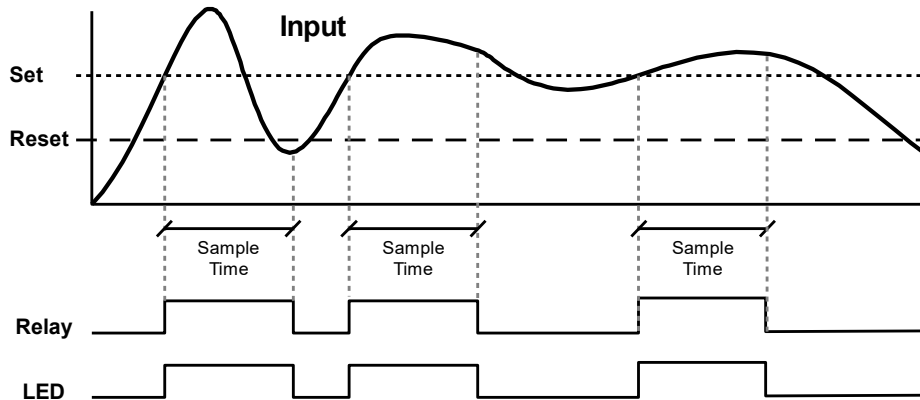

When the signal crosses the set point, the relay trips and the sample time starts. After the sample time has elapsed, the relay resets. The cycle repeats every time the set point is crossed, going up for high alarms and going down for low alarms.

The sample time can be programmed between 0.1 and 5999.9 seconds.

Signal Loss or Loop Break Relay Operation

The following graph shows the loop break relay operation for a high alarm relay.

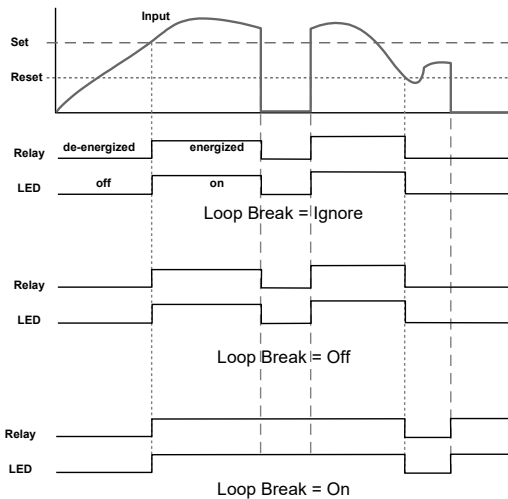

When the meter detects a break in the 4-20 mA loop, the relay will go to one of the following selected actions:

1. Turn On (Go to alarm condition)
2. Turn Off (Go to non-alarm condition)
3. Ignore (Processed as a low signal condition)

Time Delay Operation

The following graphs show the operation of the time delay function.

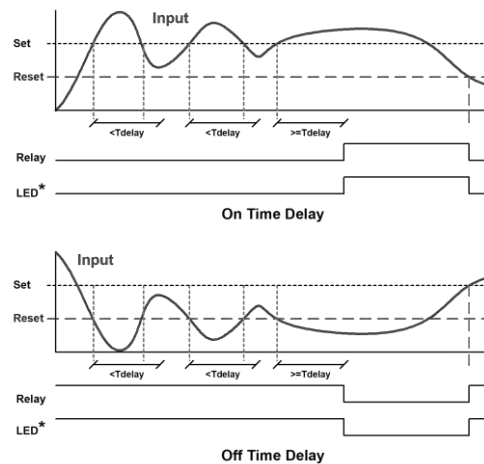

When the signal crosses the set point, the *On* time delay timer starts and the relay trips when the time delay has elapsed. If the signal drops below the set point (high alarm) before the time delay has elapsed, the *On* time delay timer resets and the relay does not change state. The same principle applies to the *Off* time delay.

Note: If "Automatic or Manual (A-n, An)" reset mode is selected, the LED follows the reset point and not the relay state when the relay is acknowledged.

Relay Operation Details

Overview

The relay capabilities of the meter expand its usefulness beyond simple indication to provide users with alarm and control functions. These capabilities include front panel alarm status LEDs as well as either 2 or 4 internal relays. Typical applications include high or low temperature, level, pressure or flow alarms, control applications such as simple on/off pump control, and pump alternation control for up to 8 pumps. There are four basic ways the relays can be used:

1. High or Low Alarms with Latching or Non-Latching Relays
2. Simple On/Off Control with 100% Adjustable Deadband
3. Sampling (Based on Time)
4. Pump Alternation Control for up to 8 Pumps

Relays Auto Initialization

When power is applied to the meter, the front panel LEDs and alarm relays will reflect the state of the input to the meter. The following table indicates how the alarm LEDs and relays will react on power-up based on the set and reset points:

Alarm #	HI or LO Alarm	Set Point	Reset Point	Power-Up Reading	Relay & LED
1	HI	10 ^{FT} 0 ^{IN} 0/16	5 ^{FT} 0 ^{IN} 0/16	4 ^{FT} 11 ^{IN} 15/16	Off
2	LO	7 ^{FT} 0 ^{IN} 0/16	9 ^{FT} 0 ^{IN} 0/16	4 ^{FT} 11 ^{IN} 15/16	On
3	LO	2 ^{FT} 6 ^{IN} 0/16	4 ^{FT} 0 ^{IN} 0/16	4 ^{FT} 11 ^{IN} 15/16	Off
4	HI	4 ^{FT} 6 ^{IN} 0/16	2 ^{FT} 0 ^{IN} 0/16	4 ^{FT} 11 ^{IN} 15/16	On

Fail-Safe Operation

The following table indicates how the relays behave based on the fail-safe selection for each relay:

Note: NO = Normally Open, NC = Normally Closed. This refers to the condition of the relay contacts when the power to the meter is off.

Fail-Safe Selection	Non-Alarm State		Alarm State		Power Failure
	NO	NC	NO	NC	
Off	Open	Closed	Closed	Open	Relays go to non-alarm state
On	Closed	Open	Open	Closed	Relays go to alarm state

Front Panel LEDs

The LEDs on the front panel provide status indication for the following:

LED	Status
1	Alarm 1
2	Alarm 2
3	Alarm 3
4	Alarm 4

The meter is supplied with four alarm points that include front panel LEDs to indicate alarm conditions. This standard feature is particularly useful for alarm applications that require visual-only indication. The LEDs are controlled by the set and reset points programmed by the user. When the display reaches a set point for a high or low alarm, the corresponding alarm LED will turn on. When the display returns to the reset point the LED will go off. The front panel LEDs respond differently for latching and non-latching relays.

For non-latching relays, the LED is always off during normal condition and always on during alarm condition, regardless of the state of the relay (e.g. Relay acknowledged after alarm condition).

For latching relays, the alarm LEDs reflect the status of the relays, regardless of the alarm condition. The following tables illustrate how the alarm LEDs function in relation to the relays and the acknowledge button (Default: F3 key assigned to ACK).

Latching and Non-Latching Relay Operation

The relays can be set up for latching (manual reset) or non-latching (automatic reset) operation.

The On and Off terminology does not refer to the status of the relay's coil, which depends on the fail-safe mode selected.

Relay terminology for following tables

Terminology	Relay Condition
On	Alarm (Tripped)
Off	Normal (Reset)
Ack	Acknowledged

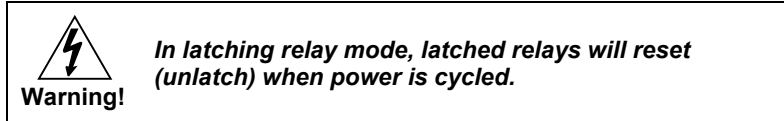

Non-Latching Relay (Αυτο)

In this application, the meter is set up for automatic reset (non-latching relay). Acknowledging the alarm while it is still present has no effect on either the LED or the relay. When the alarm finally goes away, the relay automatically resets and the LED also goes off.

Automatic reset only

Condition	LED	Relay
Normal	Off	Off
Alarm	On	On
Ack (No effect)	On	On
Normal	Off	Off

Non-Latching Relay (Α-πρ Απ)

In this application, the meter is set up for automatic and manual reset at any time (non-latching relay). The LED and the relay automatically reset when the meter returns to the normal condition.

The next time an alarm occurs, the operator acknowledges the alarm manually while the alarm condition still exists. This causes the relay to reset, but the LED stays on until the meter returns to the normal condition.

Automatic + manual reset at any time

Condition	LED	Relay
Normal	Off	Off
Alarm	On	On
Normal	Off	Off
Next Alarm	On	On
Ack	On	Off
Normal	Off	Off

Latching Relay (ΛΡεεΗ)

In this application, the meter is set up for manual reset at any time. Acknowledging the alarm even if the alarm condition is still present resets the relay and turns off the LED.

Manual reset any time

Condition	LED	Relay
Normal	Off	Off
Alarm	On	On
Ack	Off	Off

Latching Relay (Λε-εΛε)

In this application, the meter is set up for manual reset only after the signal passes the reset point (alarm condition has cleared). Acknowledging the alarm while it is still present has no effect on either the LED or the relay. When the alarm is acknowledged after it returns to the normal state, the LED and the relay go off. Notice that the LED remains on, even after the meter returns to the normal condition. This is because, for latching relays, the alarm LED reflects the status of the relay, regardless of the alarm condition.

Manual reset only after alarm condition has cleared

Condition	LED	Relay
Normal	Off	Off
Alarm	On	On
Ack (No effect)	On	On
Normal	On	On
Ack	Off	Off

Acknowledging Relays

There are two ways to acknowledge relays programmed for manual reset:

1. Via the programmable front panel function keys F1-F3 (Default: F3 assigned to ACK).
2. Remotely via a normally open pushbutton wired across one of the digital inputs and the +5 V terminals on the digital I/O terminal, or using the F4 digital input, which is triggered with a contact closure to COM, or with an active low signal (see page 18).

When the ACK button or the assigned digital input is closed, all relays programmed for manual reset are acknowledged.

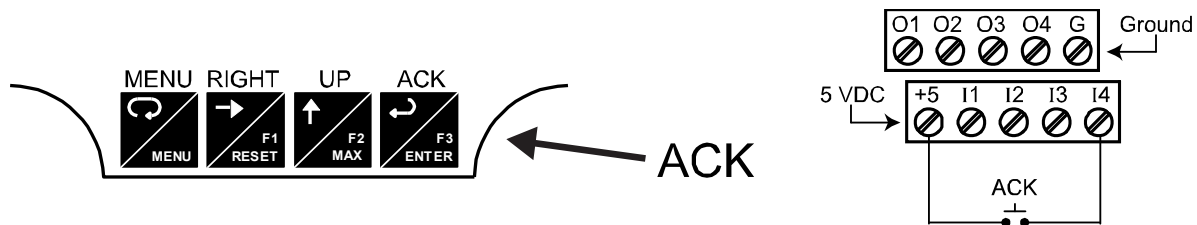

Figure 23. Acknowledge Relays w/Function Key or Digital Input

Pump Alternation Control Applications (ALTERN)

For pump control applications where two or more similar pumps are used to control the level of a tank or a well, it is desirable to have all the pumps operate alternately. This prevents excessive wear and overheating of one pump over the lack of use of the other pumps.

Up to 8 relays can be set up to alternate every time an on/off pump cycle is completed. The set points and reset points can be programmed, so that the first pump on is the first pump off.

Application #1: Pump Alternation Using Relays 1 & 2

1. Relays 1 and 2 are set up for pump alternation.
2. Relays 3 and 4 are set up for low and high alarm indication.

Set and Reset Point Programming

Relay	Set Point	Reset Point	Function
1	30 ^{FT} 0 ^{IN} 0/16	10 ^{FT} 0 ^{IN} 0/16	Controls pump #1
2	35 ^{FT} 0 ^{IN} 0/16	5 ^{FT} 0 ^{IN} 0/16	Controls pump #2
3	4 ^{FT} 0 ^{IN} 0/16	9 ^{FT} 0 ^{IN} 0/16	Controls low alarm
4	40 ^{FT} 0 ^{IN} 0/16	29 ^{FT} 0 ^{IN} 0/16	Controls high alarm

Pump Alternation Operation

1. Pump #1 turns on when level reaches 30^{FT}, when level drops below 10^{FT}, pump #1 turns off.
2. The next time level reaches 30^{FT}, pump #2 turns on, when level drops below 10^{FT}, pump #2 turns off.
3. If the level doesn't reach 35^{FT}, pump #1 and pump #2 will be operating alternately.
4. If pump #1 cannot keep the level below 35^{FT}, pump #2 will turn on at 35^{FT}, then as the level drops to 10^{FT}, pump #1 turns off, pump #2 is still running and shuts off below 5^{FT}.
5. Notice that with the set and reset points of pump #2 outside the range of pump #1, the first pump on is the first pump to go off. This is true for up to 8 alternating pumps, if setup accordingly.
6. Relay #3 will go into alarm if the level drops below 4^{FT} and relay #4 will go into alarm if the level exceeds 40^{FT}.
7. Adding the 4 external relays, expansion module allows using the 4 SPDT internal relays for pump alternation and the 4 SPST external relays for high, high-high, low, and low-low alarm indication.

Application #2: Pump Alternation Using Relays 3 & 4

1. Relays 1 and 2 are set up for low and high alarm indication.
2. Relays 3 and 4 are set up for pump alternation.

Set and Reset Point Programming			
Relay	Set Point	Reset Point	Function
1	4 ^{FT} 10 ^{IN} 0/16	7 ^{FT} 6 ^{IN} 0/16	Controls low alarm
2	45 ^{FT} 0 ^{IN} 0/16	42 ^{FT} 0 ^{IN} 0/16	Controls high alarm
3	40 ^{FT} 0 ^{IN} 0/16	9 ^{FT} 0 ^{IN} 0/16	Controls backup pump
4	30 ^{FT} 0 ^{IN} 0/16	10 ^{FT} 0 ^{IN} 0/16	Controls main pump

The following graphics provide a visual representation of a typical pump alternation application with high and low alarm monitoring:

1. Relay #4 turns the main pump on at 30^{FT} and turns it off at 10^{FT}.

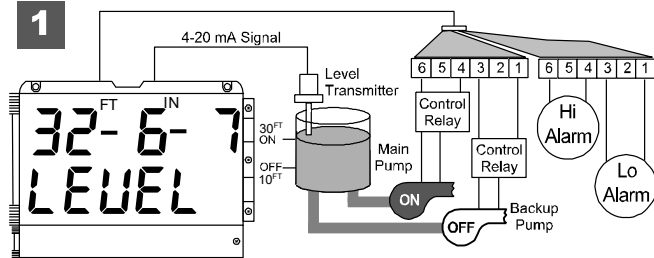

2. With the Pump Alternation feature activated, the next time the level reaches 30^{FT}, relay #3 transfers and starts the backup pump.

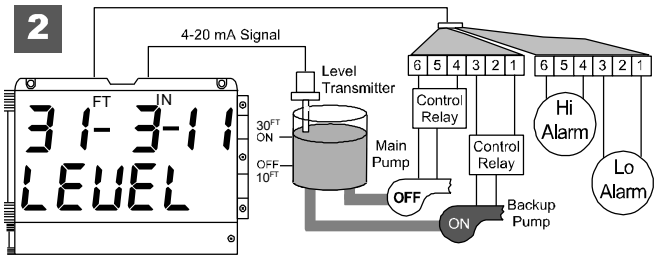

3. If the backup pump is not able to keep up, and the level reaches 40^{FT}, relay #4 transfers and starts the main pump as well.

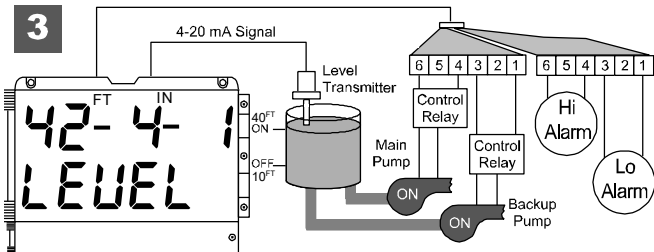

4. Relay #2 trips the High Level Alarm at 45^{FT} and resets at 42^{FT}.

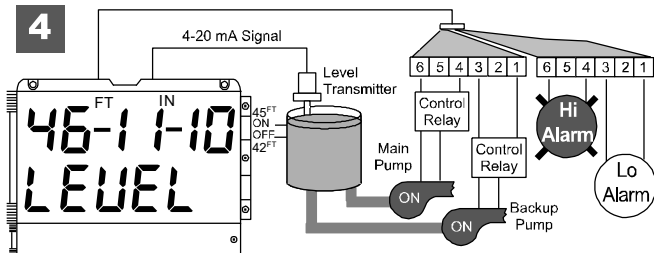

5. Relay #1 trips the Low Level Alarm at 4^{FT}10^{IN} and resets at 7^{FT}6^{IN}.

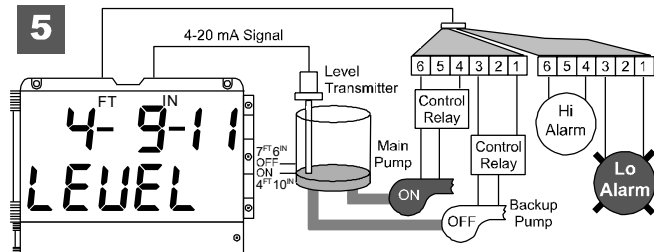

Setting up the Interlock Relay (Force On) Feature

Relays 1-4 can be set up as interlock relays. To set up the relays for the interlock feature:

1. Access the *Setup – Relay – Action* menu and set the action to off.

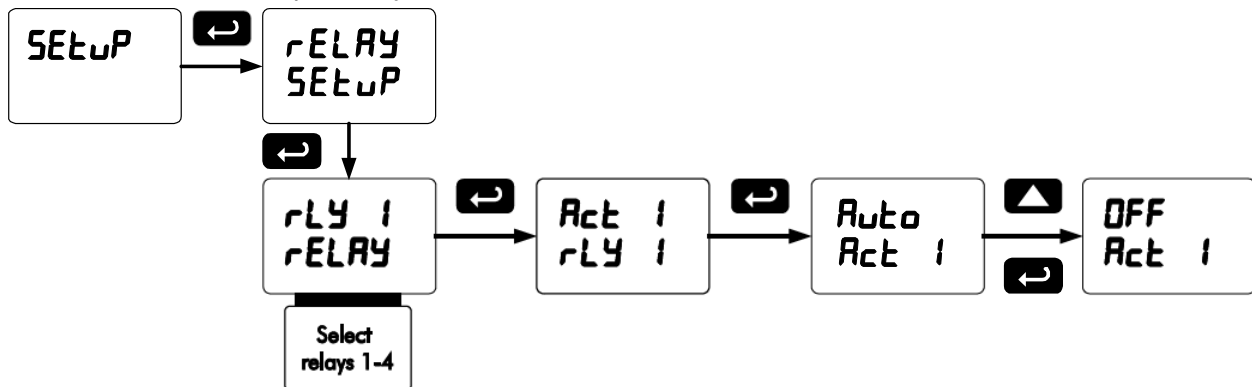

2. In the *Advanced features – User* menu program any of the digital inputs to *Force On* any of the internal relays (1-4).

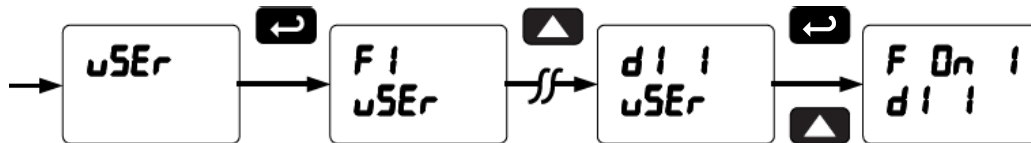

3. Connect a switch or dry contact between the +5V terminal and the corresponding digital input (dI-1 to dI-4) terminal.

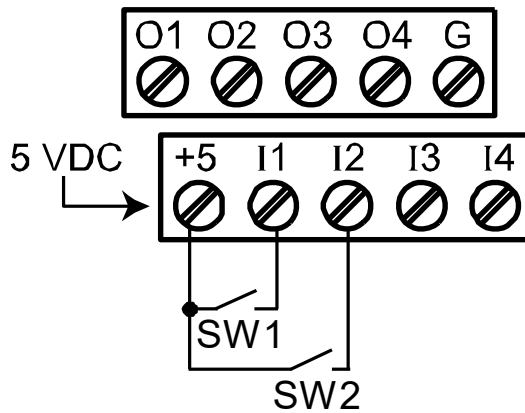

Interlock Relay Operation Example

Relays 1 & 2 are configured to energize (their front panel LEDs are off) when SW1 & SW2 switches (above) are closed. If the contacts to these digital inputs are opened, the corresponding front panel LEDs flash indicating this condition. The processes being controlled by the interlock relay will stop, and will re-start only after the interlock relay is re-activated by the digital inputs (switches).

Note: If multiple digital inputs are assigned to the same relay, then the corresponding logic is (AND) – i.e. both switches must be closed to trip the relay.

Scaling the 4-20 mA Analog Output (Rout)

The 4-20 mA analog output can be scaled to provide a 4-20 mA signal for any display range selected.

No equipment is needed to scale the analog output; simply program the display values to the corresponding mA output signal.

The *Analog Output* menu is used to program the 4-20 mA output based on display values.

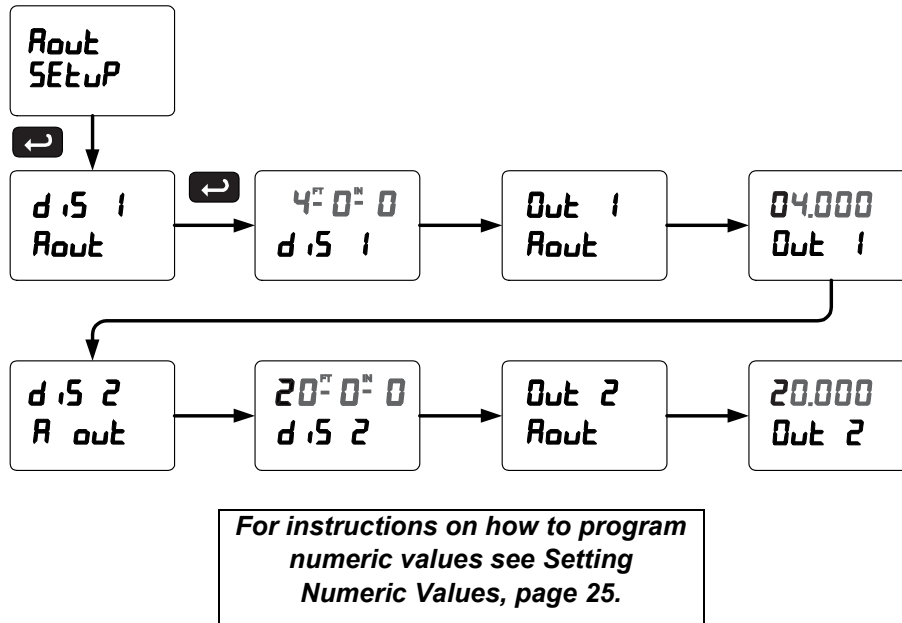

Reset Menu (rESEt)

The *Reset* menu is used to reset the maximum or minimum reading (peak or valley) reached by the process; both may be reset at the same time by selecting “reset high & low” (r5t HL). The tare value used to zero the display may be reset by selecting “reset tare” (r5t tr).

Control Menu (Control)

The *Control* menu is used to control the 4-20 mA analog output and the relays manually, ignoring the input. Each relay and analog output can be programmed independently for manual control. Selecting automatic control sets all relays and analog output for automatic operation.

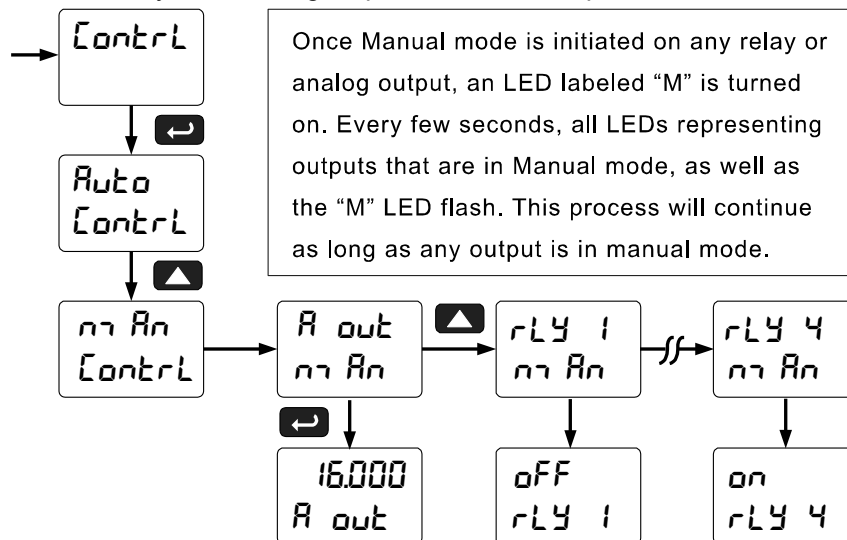

Setting up the Password (PASS)

The *Password* menu is used for programming three levels of security to prevent unauthorized changes to the programmed parameter settings.

- Pass 1: Allows use of function keys and digital inputs
- Pass 2: Allows use of function keys, digital inputs and editing set/reset points
- Pass 3: Restricts all programming, function keys, and digital inputs.

Protecting or Locking the Meter

Enter the *Password* menu and program a six-digit password.

For instructions on how to program numeric values see *Setting Numeric Values*, page 25.

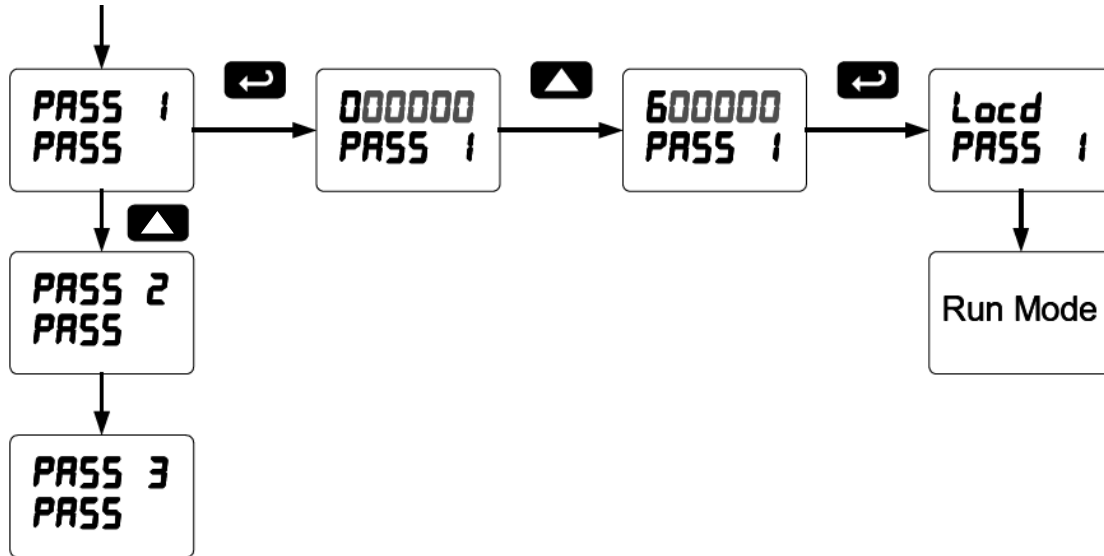

Record the password for future reference. If appropriate, it may be recorded in the space provided.

Model:	
Serial Number:	
Password 1:	__ __ __ __ __ __
Password 2:	__ __ __ __ __ __
Password 3:	__ __ __ __ __ __

Making Changes to a Password Protected Meter

If the meter is password protected, the meter will display the message *Locd* (Locked) when the Menu button is pressed. Press the Enter button while the message is being displayed and enter the correct password to gain access to the menu. After exiting the programming mode, the meter returns to its password protected condition.

Disabling Password Protection

To disable the password protection, access the *Password* menu and enter the correct password twice, as shown below. The meter is now unprotected until a new password is entered.

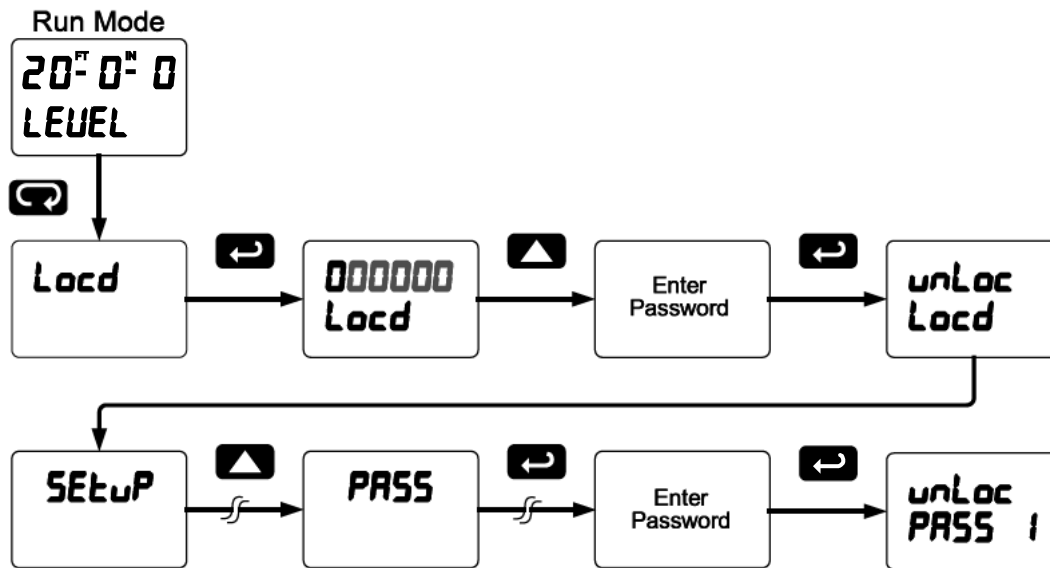

If the correct six-digit password is entered, the meter displays the message *unLoc* (unlocked) and the protection is disabled until a new password is programmed.

If the password entered is incorrect, the meter displays the message *Locd* (Locked) for about two seconds, and then it returns to Run Mode. To try again, press Enter while the *Locked* message is displayed.

Did you forget the password?

The password may be disabled by entering a master password once. If you are authorized to make changes, enter the master password 508655 to unlock the meter.

Advanced Features Menu

To simplify the setup process, functions not needed for most applications are located in the *Advanced Features* menu.

Press and hold the Menu button for three seconds to access the advanced features of the meter.

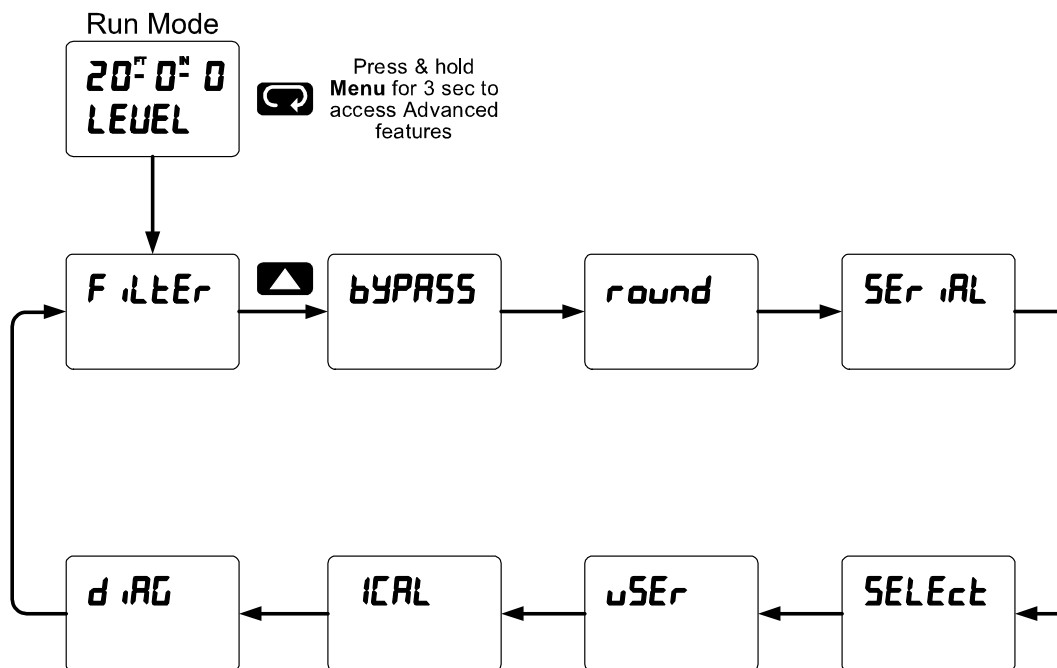

Advanced Features Menu & Display Messages

The following table shows the functions and messages of the *Advanced Features* menu in the order they appear in the menu.

Display	Parameter	Action/Setting
F ILtEr	Filter	Set noise filter value
bYPASS	Bypass	Set filter bypass value
round	Round	Set the rounding value for display variables
SEr iAL	Serial	Set serial communication parameters
SLAVE Id	Slave ID	Set slave ID or meter address
bAud	Baud rate	Select baud rate
tr dLY	Transmit delay	Set transmit delay for serial communication
PRr itY	Parity	Select parity: Even, Odd, or None with 1 or 2 stop bits
t-bYt	Time byte	Set byte-to-byte timeout
SELEct	Select	Enter the Select menu (function, cutoff, out)
Functn	Signal input conditioning	Select linear, square root, programmable exponent, or round horizontal tank function
L inERr	Linear	Set meter for linear function and select number of linearization points
PV 1	PV1	Select PV1 number of linearization points
L inERr	Linear	Set meter for linear function and select number of linearization points
no Pt5	Number of	Set PV1 for 2 to 32-point linearization

Display	Parameter	Action/Setting
	<i>points</i>	Set PV2 for 2 to 8-point linearization
PV 2	PV2	Select PV2 number of linearization points
rhk	Round horizontal tank	Set meter for round horizontal tank volume calculation
inch	Dimension	Calculate volume in gallons
l	Dimension	Calculate volume in liters
d	Diameter	Enter the tank's diameter in inches
L	Length	Enter the tank's length in inches
C	Cutoff	Set low-flow cutoff
RoutPr	Analog output programming	Program analog output parameters
S	Source	Select source for the 4-20 mA output
O	Overrange	Program mA output for display overrange
U	Underrange	Program mA output for display underrange
b	Break	Set input break condition operation
M	Maximum	Program maximum mA output allowed
m	Minimum	Program minimum mA output allowed
CAL	Calibrate	Calibrate 4-20 mA output (internal reference source used for scaling the output)
4	4 mA output	Enter mA output value read by milliamp meter with at least 0.001 mA resolution
20	20 mA output	Enter mA output value read by milliamp meter with at least 0.001 mA resolution
uSEr	User I/O	Assign function keys and digital I/O
F 1	F1 function key	Assign F1 function key
F2	F2 function key	Assign F2 function key
F3	F3 function key	Assign F3 function key
F4	F4 function	Assign F4 function (digital input)
d 1	Digital input 1	Assign digital input 1 – 4, if expansion modules are connected
dO 1	Digital output 1	Assign digital output 1 – 4, if expansion modules are connected
I	Internal source calibration	Enter internal source calibration (used for scaling the meter without a signal source)
C	Current calibration	Calibrate 4-20 mA current input (internal reference source used for scaling the input)
C L	Current low	Calibrate low current input (e.g. 4 mA)
C H	Current high	Calibrate high current input (e.g. 20 mA)
V	Voltage calibration	Calibrate voltage input
V L	Voltage low	Calibrate low voltage input (e.g. 0 V)
V H	Voltage high	Calibrate high voltage input (e.g. 10 V)
d	Diagnostics	Display parameter settings
L	LED test	Test all LEDs
Info	Information	Display software and S/N information
Erase	Erase	Delete the MeterView Pro installation files from the meter

Noise Filter (*FILTER*)

The noise filter is available for unusually noisy signals that cause an unstable process variable display. The noise filter averages the input signal over a certain period. The filter level determines the length of time over which the signal is averaged. The filter level can be set between 2 and 199. The higher the filter level, the longer the averaging time and so the longer it takes the display to settle to its final value. Setting the filter level to zero disables the filter function.

Noise Filter Bypass (*BYPASS*)

The noise filter bypass changes the behavior of the meter so that small variations in the signal are filtered out but large abrupt changes in the input signal are displayed immediately. The bypass value determines the minimum amount of signal change to be displayed immediately. All signal changes smaller than the bypass value are filtered or averaged by the meter. The noise filter bypass may be set between 0.1 and 99.9% of full scale.

Rounding Feature (*round*)

The rounding feature is used to give the user a steadier display with fluctuating signals. Rounding is used in addition to the filter function.

Rounding causes the display to round to the nearest value according the rounding selected. See examples below:

Rounding Selection	Actual Value	Secondary Display Value	Main Display Value	Actual Value	Secondary Display Value	Main Value
1	12.093	12.093	12 ^{FT} 11 ^{IN} 2/16	12.953	12.953	12 ^{FT} 11 ^{IN} 7/16
5	12.093	12.095	12 ^{FT} 11 ^{IN} 2/16	12.953	12.955	12 ^{FT} 11 ^{IN} 7/16
10	12.093	12.090	12 ^{FT} 11 ^{IN} 1/16	12.953	12.950	12 ^{FT} 11 ^{IN} 6/16
50	12.093	12.100	12 ^{FT} 11 ^{IN} 3/16	12.953	12.950	12 ^{FT} 11 ^{IN} 6/16

Modbus RTU Serial Communications (SERIAL)

The meter is equipped with serial communications capability as a standard feature using Modbus RTU Serial Communication Protocol.

The meter may be connected to a PC for initial configuration via the onboard micro USB connection. For ongoing digital communications with a computer or other data terminal equipment, an RS-232, or RS-485 option is required; see *Ordering Information* on page 4 for details.

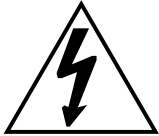

Warning!

Do not connect any equipment other than Precision Digital's expansion modules, cables, or meters to the RJ45 M-LINK connector. Otherwise damage will occur to the equipment and the meter.

Do not disconnect the RJ45 connector located to the left of the power terminal block. Doing so will disable the onboard digital I/O, RS-485 serial communications, and M-Link functionality.

Note: More detailed instructions are provided with each optional serial communications adapter.

Note: Refer to the Modbus Register Tables located at www.predig.com for details.

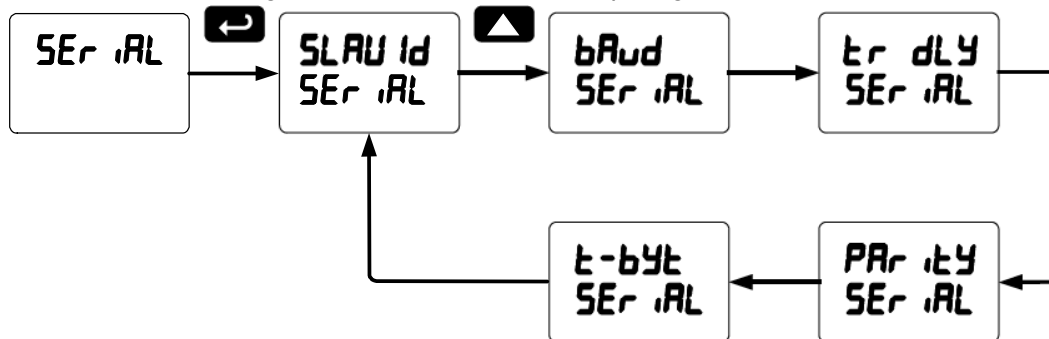

When using more than one meter in a multi-drop mode, each meter must be provided with its own unique address. The meter address (Slave ID) may be programmed between 1 and 247. The transmit delay may be set between 0 and 199 ms. The parity can be set to even, odd, or none with 1 or 2 stop bits.

Select Menu (SELEct)

The *Select* menu is used to select the signal input conditioner applied to the input (linear, square root, programmable exponent, or round horizontal tank), low-flow cutoff, and analog output programming. The multi-point linearization is part of the linear function selection.

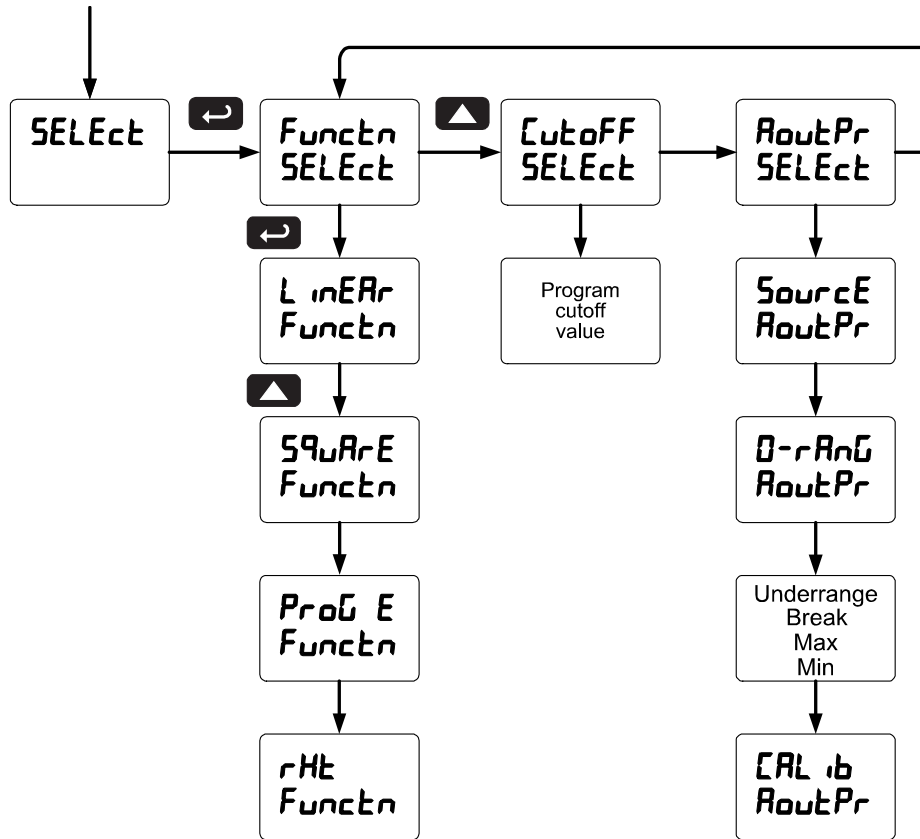

Signal Input Conditioning (Functn)

The *Function* menu is used to select the signal input conditioner applied to the input: linear, square root, programmable exponent, or round horizontal tank volume calculation. The multi-point linearization is part of the linear function selection.

Meters are set up at the factory for linear function with 2-point linearization. The linear function provides a display that is linear with respect to the input signal.

Square Root Linearization (SQURrE)

The square root function can be used to linearize the signal from a differential pressure transmitter and display flow rate in engineering units.

Programmable Exponent Linearization (ProG E)

The programmable exponent can be used to linearize the signal from level transmitters in open-channel flow applications using weirs and flumes.

Multi-Point Linearization (L inERr)

Meters are set up at the factory for linear function with 2-point linearization. Up to 32 linearization points can be selected for PV1 under the linear function. The multi-point linearization can be used to linearize the display for non-linear signals such as those from level transmitters used to measure volume in odd-shaped tanks or to convert level to flow using weirs and flumes with complex exponent.

If the dual-scale level feature has been selected, the menus for PV1 & PV2 are enabled. PV2 can be programmed with up to 8 linearization points.

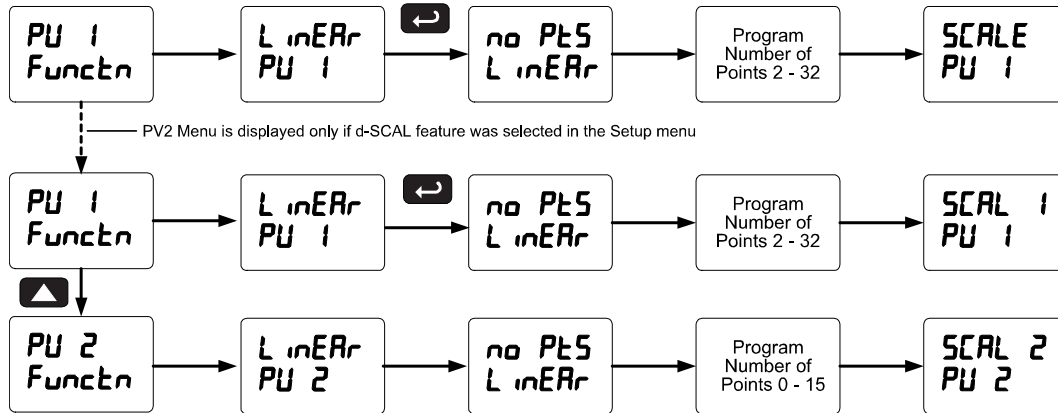

Round Horizontal Tank Linearization (rHt)

This function automatically calculates the volume in a round horizontal tank with flat ends.

Set the display for the desired decimal point and engineering units before entering the round horizontal tank function. Select units, inches or cm for the tank dimensions. Enter the diameter and the length in inches and the results are calculated automatically in US gallons.

The meter can be scaled to display the volume in any engineering unit.

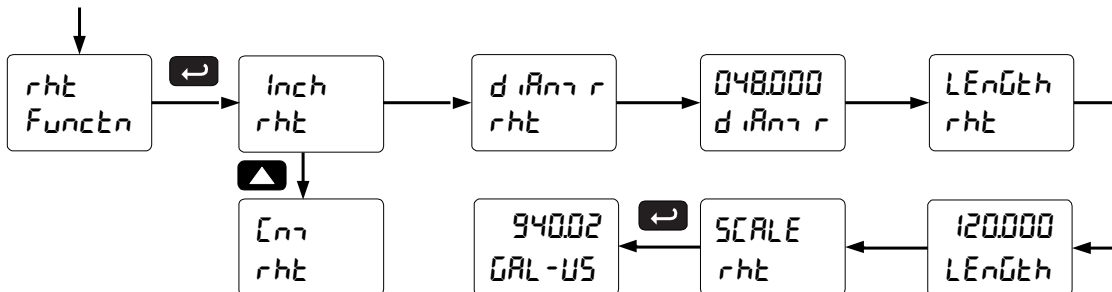

Note: After Scale is displayed continue pressing the Enter button until the meter completes the scaling of the input and display values.

Changing the Volume from Gallons to Liters

In the above graphic, entering the 48" for the diameter and 120" for the length of the round horizontal tank, the meter automatically calculates that the volume of the tank is 940.02 gallons.

1. Convert gallons to liters
2. 1 US gallon = 3.7854 L
3. 940.02 gal = 3558.4 L
4. Go to the *Setup* menu and change the decimal point to 1 decimal.
5. Go to the *Program – Scale* menu and press Enter until d.5 2 is shown on the main display.
6. Press Enter and change the display 2 value to 3558.4.
7. The meter is now displaying the volume in liters.

Note: The display can be scaled to display the volume in any engineering units.

Low-Flow Cutoff (Cutoff)

The low-flow cutoff feature allows the meter to be programmed so that the often-unsteady output from a differential pressure transmitter, at low flow rates, always displays zero on the meter.

The cutoff value may be programmed from 0 to 999999. The meter will display zero below the cutoff value. Programming the cutoff value to zero disables the cutoff feature.

Analog Output Programming (Analog Pr)

The *Analog Output Programming* menu is used to program the behavior of the 4-20 mA output. The following parameters and functions are programmed in this menu:

1. Source: Source for generating the 4-20 mA output (e.g. PV)
2. Overrange: Analog output value with display in overrange condition
3. Underrange: Analog output value with display in underrange condition
4. Break: Analog output value when loop break is detected
5. Max: Maximum analog output value allowed regardless of input
6. Min: Minimum analog output value allowed regardless of input
7. Calibrate: Calibrate the internal 4-20 mA source reference used to scale the 4-20 mA output

Analog Output Source

The source for generating the 4-20 mA output may be assigned to the process variable, maximum or minimum value reached by the process, one of the set points, or the Modbus PV input.

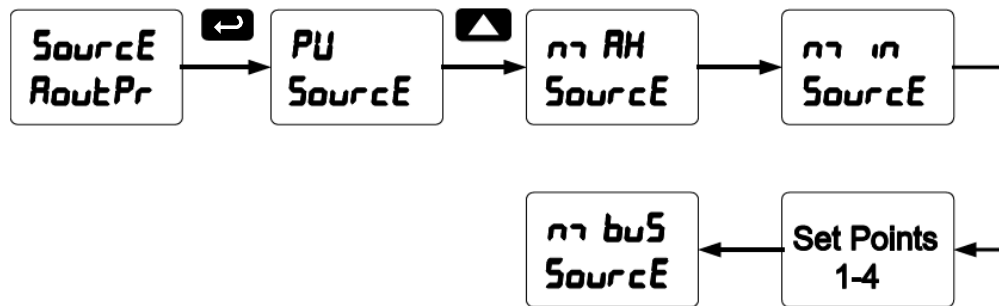

Analog Output Calibration

To perform the analog output calibration, it is recommended to use a milliamp meter with a resolution of at least 0.1 μ A to measure the output current. The values saved internally during this procedure are used for scaling the 4-20 mA output in the *Setup* menu.

Programmable Function Keys User Menu (User)

The *User* menu allows the user to assign the front panel function keys F1, F2, and F3, the digital input F4 (a digital input located on the signal input connector), and up to eight additional digital inputs to access most of the menus or to activate certain functions immediately (e.g. reset max & min, hold relay states, etc.). This allows the meter to be greatly customized for use in specialized applications.

Up to eight digital outputs can be assigned to a number of actions and functions executed by the meter (i.e. alarms, relay acknowledgement, reset max, min, or max & min, tare, and reset tare). The digital outputs can be used to trigger external alarms or lights to indicate these specific events.

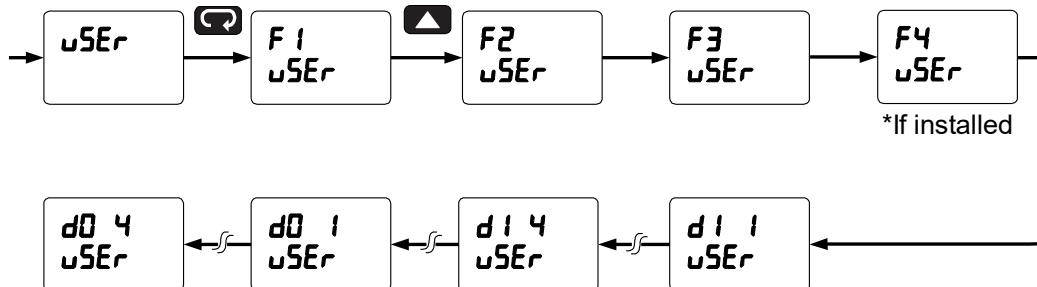

Function Keys & Digital I/O Available Settings

Refer to the following table for descriptions of each available function key or digital I/O setting.

Display	Description	Display	Description
r5t Hi	Reset the stored maximum display value	Ln2 Hi	Display maximum display value on line 2
r5t Lo	Reset the stored minimum display value	Ln2 Lo	Display minimum display value on line 2
r5t HL	Reset the stored maximum & minimum display values	Ln2 HL	Display maximum & minimum display values on line 2
tArE	Capture tare and zero the display	F On I*	Force relay 1 (*through 4) into the on state. This function is used in conjunction with a digital input expansion module to achieve interlock functionality. See page 41 for details about interlock relays.
r5t tr	Reset captured tare and resume normal operation	Control	Directly access the control menu
rELAY	Directly access the relay menu	d.SRBL	Disable the selected function key or digital I/O
SEt I*	Directly access the set point menu for relay 1 (*through 8)	RcH	Acknowledge all active relays that are in a manual operation mode such as auto-manual or latching
rLY d	Disable all relays until a button assigned to <i>enable relays (rLY E)</i> is pressed	rESEt	Directly access the reset menu
rLY E	Enable all relays to function as they have been programmed	rEnu	Mimic the menu button functionality (digital inputs only)
0 Hold	Hold current relay states as they are until a button assigned to <i>enable relays (rLY E)</i> is pressed	rGHt	Mimic the right arrow/F1 button functionality (digital inputs only)
d Hold	Hold the current display value momentarily while the function key or digital input is active. The process value will continue to be calculated in the background.	uP	Mimic the up arrow/F2 button functionality (digital inputs only)
Ln1 Hi	Display maximum display value on line 1	EntEr	Mimic the enter/F3 button functionality (digital inputs only)
Ln1 Lo	Display minimum display value on line 1	ALAr I*	Provide indication when alarm 1 (*through 8) has been triggered (digital outputs only)
Ln1 HL	Display maximum & minimum display values on line 1		

Tare (tArE)

The tare function zero's out the display. In the case of scale weight, tare is used to eliminate container weight and provide net weight readings. There are two tare functions; Capture Tare and Reset Tare.

When the capture tare function is used, the display reading is offset by the displayed amount to make the displayed value zero. This modified display value is the net value. The originally displayed value without the tare offset is the gross value. Both may be chosen as a display option.

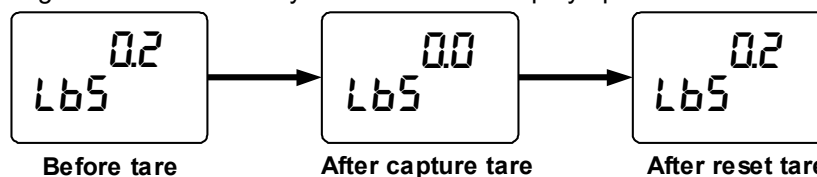

Reset tare removes the display offset of the net value, and the gross and net values become the same until a new capture tare is entered.

Internal Source Calibration (ICAL)

The meter is factory calibrated prior to shipment to read in milliamps and volts depending on the input selection. The calibration equipment is certified to NIST standards.

The use of calibrated signal sources is necessary to calibrate the internal source of the meter. The meter's internal source is what allows the user to scale the meter without applying a signal. Check calibration of the meter at least every 12 months. Each input must be recalibrated separately.

Notes:

1. If meter is in operation and it is intended to accept only one input type (e.g. 4-20 mA), recalibration of other input is not necessary.
2. Allow the meter to warm up for at least 15 minutes before performing the internal source calibration procedure.

The Internal calibration menu is part of the Advanced Features menu.

1. Press and hold the Menu button for three seconds to access the advanced features of the meter.
2. Press the Up arrow button to scroll to the *Internal calibration* menu (ICAL) and press Enter.
3. The meter displays either current calibration (ICAL) or voltage calibration (VICAL), according to the input setup. Press Enter to start the calibration process.

Example of Internal Calibration for current input:

4. The meter displays *low* input current message (Lo CAL). Apply the low input signal and press Enter. The display flashes for a moment while the meter is accepting the low input signal.
5. After the display stops flashing, a number is displayed with the leftmost digit brighter than the rest. The bright digit is the active digit that can be changed by pressing the Up arrow button. Press the Right arrow button to move to the next digit.
6. Set the display value to correspond to the input signal being calibrated, typically 4.000 mA.
7. The display moves to the *high* input calibration (Hi CAL). Apply the high input signal and press Enter.
8. Set the display for the high input calibration, in the same way as it was set for the low input calibration, typically 20.000 mA.

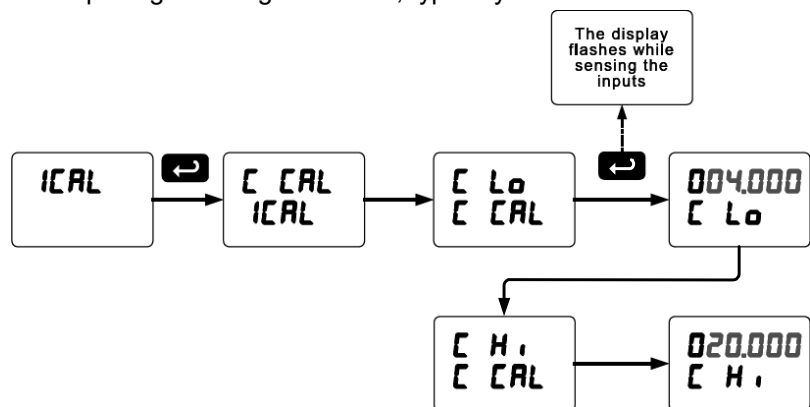

The graphic above shows the calibration of the current input. The voltage input is calibrated in a similar way.

Tips:

- Low and high input signals can be any valid values within the range of the meter.
- Observe minimum input span requirements between input 1 and input 2.
- Low input should be less than high input signal.

<p style="text-align: center;">Error Message (Error)</p> <p>An error message indicates that the calibration or scaling process was not successful. The error message might be caused by any of the following conditions:</p> <ol style="list-style-type: none"> 1. Input signal is not connected to the proper terminals, or it is connected backwards. 2. Wrong signal selection in <i>Setup</i> menu. 3. Minimum input span requirements not maintained. 	<p style="text-align: center;">Minimum Input Span</p> <p>The minimum input span is the minimum difference between input 1 and input 2 signals required to complete the calibration or scaling of the meter.</p> <table border="1" style="width: 100%; border-collapse: collapse; margin-top: 10px;"> <thead> <tr> <th style="text-align: left;">Input Range</th> <th style="text-align: left;">Input 1 & Input 2 Span</th> </tr> </thead> <tbody> <tr> <td>4-20 mA</td> <td>0.15 mA</td> </tr> <tr> <td>±10 VDC</td> <td>0.01 VDC</td> </tr> </tbody> </table>	Input Range	Input 1 & Input 2 Span	4-20 mA	0.15 mA	±10 VDC	0.01 VDC
Input Range	Input 1 & Input 2 Span						
4-20 mA	0.15 mA						
±10 VDC	0.01 VDC						

Meter Operation





The meter is capable of accepting current (0-20 mA, 4-20 mA) and voltage signals (0-5 V, 1-5 V, 0-10 V, ± 10 V) and displaying these signals in engineering units from $-9^{FT}11^{IN(15/16 \text{ or } 7/8)}$ - $99^{FT}11^{IN(15/16 \text{ or } 7/8)}$ on display line 1 and units from -99999 to 999999 on display line 2 (e.g. a 4-20 mA signal could be displayed as $0^{FT}0^{IN 0/16}$ to $25^{FT}0^{IN 0/16}$ on the main display (Line 1) and -50.000 to 50.000 on the secondary display (Line 2)).

The dual-line display can be customized by the user to operate in such a way as to satisfy a specific application. Typically, the main display is used for the process variable while the second display is used for engineering units, custom legend, or set point indication.

The analog input can be scaled to display the process in two different scales; for example: with *d-SCAL* enabled, the main display could indicate level in feet and the second display could indicate the volume in gallons.

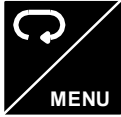
Additionally, the meter can be set up to display the analog input on the main display and the Modbus input on the second display. The relays and analog output can be programmed to operate from the Modbus PV input.

Button Operation

Button Symbol	Description
<p>MENU</p> 	Press to enter or exit Programming Mode, view settings, or exit max/min readings
<p>RIGHT</p> 	Press to reset max/min readings or other parameter/function assigned through the <i>User</i> menu
<p>UP</p> 	Press to display max/min readings or other parameter/function assigned through the <i>User</i> menu
<p>ACK</p> 	Press to acknowledge relays or other parameters/function assigned through the <i>User</i> menu

Function Key Operation

During operation, the programmable function keys operate according to the way they have been programmed in the *Advanced Features – User* menu.

The table above shows the factory default settings for F1, F2, and F3.

Digital Input Operation

Five (5) digital inputs, F4-F8, come standard on the meter. These digital inputs are programmed identically to function keys F1, F2, and F3. The inputs are triggered with a contact closure to +5 (COM in the case of F4, see Digital I/O Connections on page 18 for details), or with an active low signal. During operation, digital inputs operate according to the way they are programmed in the *Advanced Features – User* menu.

Maximum/Minimum Readings

The max & min readings (peak & valley) reached by the process can be displayed either continuously or momentarily:

1. Display briefly by assigning to the F1-F3 function keys or to the digital inputs in the *User* menu.
2. Display continuously by assigning either display to max/min through the *Display* menu.

Any of the F1-F3 function keys (buttons) and the digital inputs can be programmed to reset the max & min readings. The meters are set at the factory to display the max reading by pressing the Up arrow/F2 button and to use the Right arrow/F1 button to access the *Reset* menu.

To display max reading using function key with factory defaults:

1. Press Up arrow/F2 button to display maximum reading since the last reset/power-up.
2. To reset max/min press Right arrow/F1 button to access the Reset menu. The max & min displays are reset to actual values.
3. Press Menu to exit max/min display reading.

To display max/min readings continuously:

Assign either display to Max (*d H i*), Min (*d Lo*), or toggle between Max and Min (*d HL*) every 10 seconds.

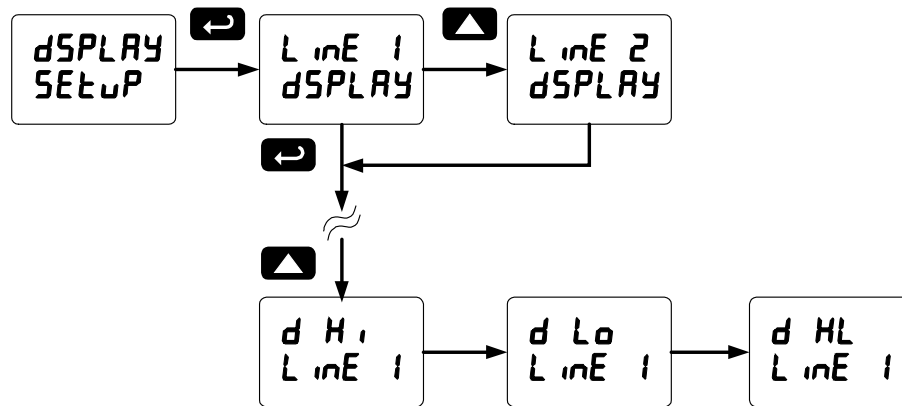

Troubleshooting

Due to the many features and functions of the meter, it's possible that the setup of the meter does not agree with what an operator expects to see. If the meter is not working as expected, refer to the *Diagnostics* menu and recommendations below.

Diagnostics Menu (*d iAG*)

The *Diagnostics* menu is located in the *Advanced Features* menu, to access *Diagnostics* menu see *Advanced Features Menu*, page 45.

This menu allows the user to test the functionality of all the meter LEDs, check the meter's software and version information, and erase the MeterView Pro software installation files from the meter. Press the Enter button to view the settings and the Menu button to exit at any time.

For a description of the diagnostic messages, see *Advanced Features Menu & Display Messages*, page 45.

Determining Software Version

To determine the software version of a meter:

1. Go to the *Diagnostics* menu (*d iAG*) and press Enter button.
2. Press Up arrow button and scroll to Information menu (*Info*).
3. Press Enter to access the software number (*5Ft*) and version (*4Er*) information. Write down the information as it is displayed. Continue pressing Enter until all the information is displayed.
4. The meter returns to Run Mode after displaying all the settings.

Reset Meter to Factory Defaults

When the parameters have been changed in a way that is difficult to determine what's happening, it might be better to start the setup process from the factory defaults.

Instructions to load factory defaults:

1. Enter the *Advanced Features* menu. See *Advanced Features Menu*, page 45.
2. Press Up arrow to go to *Diagnostics* menu
3. Press and hold Right arrow for three seconds, press Enter when display flashes *rESEt*.
Note: If Enter is not pressed within three seconds, the display returns to the *Diagnostics* menu.
4. The meter goes through an initialization sequence (similar as on power-up), and loads the factory default settings.

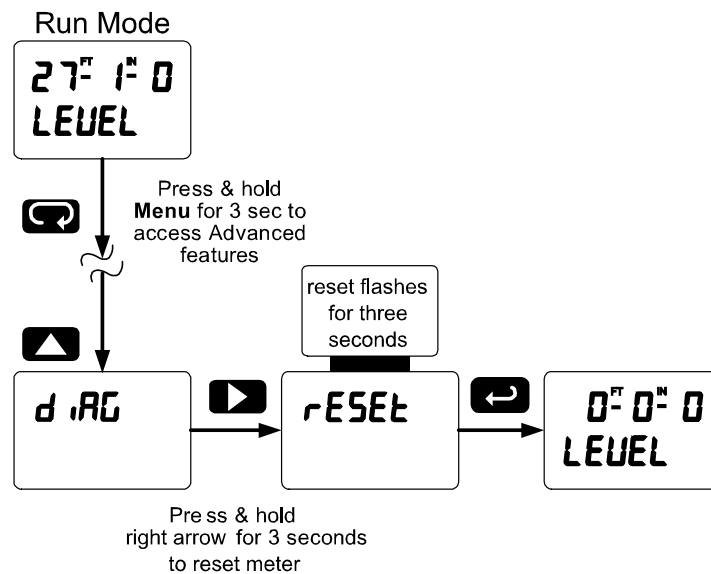

Note: The dual-scale selection for some level applications (d-SCAL) is not reset to the single scale factory default. This can be changed using the Setup – Input menu.

Factory Defaults & User Settings

The following table shows the factory setting for most of the programmable parameters on the meter.

Parameter	Display	Default Setting	Parameter	Display	Default Setting
Input type	<i>InPut</i>	4-20 mA	Off delay relay 3	<i>OFF 3</i>	0.0 sec
Dual-scale feature	<i>d-SCAL</i>	No (Single scale)	On delay relay 4	<i>On 4</i>	0.0 sec
Filter	<i>F ILtEr</i>	70	Off delay relay 4	<i>OFF 4</i>	0.0 sec
Bypass	<i>bYPASS</i>	0.2	Loop break relay 1	<i>iGnorE</i>	Ignore
Function	<i>Functn</i>	Linear	Loop break relay 2	<i>iGnorE</i>	Ignore
Number of points	<i>no Pts</i>	2	Loop break relay 3	<i>iGnorE</i>	Ignore
Programming	<i>Prog</i>	Scale	Loop break relay 4	<i>iGnorE</i>	Ignore
Input 1	<i>InP 1</i>	4.000 mA	Display 1 analog out	<i>d .5 1</i>	4 FT0IN 0/16
Display 1	<i>d .5 1</i>	4 FT0IN 0/16	Output 1 value	<i>Out 1</i>	4.000 mA
Input 2	<i>InP 2</i>	20.000 mA	Display 2 analog out	<i>d .5 2</i>	20 FT0IN 0/16
Display 2	<i>d .5 2</i>	20 FT0IN 0/16	Output 2 value	<i>Out 2</i>	20.000 mA
Decimal point	<i>dddd</i>	3 places	Source analog output	<i>Source</i>	Process Variable
Cutoff value	<i>CutoFF</i>	0.000 (disabled)	Overrange output	<i>0-rRNG</i>	21.000 mA
Display assignment	<i>dSPLAY</i>		Underrange output	<i>u-rRNG</i>	3.000 mA
Big display (Main)	<i>b iG</i>	PV: Process variable	Loop break output	<i>brEAK</i>	1.000 mA
Little display (Small)	<i>L iLtLE</i>	Eng unit default= mA	Maximum output	<i>m AH</i>	23.000 mA
Display intensity	<i>d- IntY</i>	8	Minimum output	<i>m n</i>	1.000 mA
Relay 1 action	<i>Rct 1</i>	Automatic	Slave ID (Address)	<i>SLAU id</i>	247
Relay 1 set point	<i>SEt 1</i>	1 FT0IN 0/16	Baud rate	<i>bAud</i>	9600
Relay 1 reset point	<i>rSt 1</i>	0 FT6IN 0/16	Transmit delay	<i>tr dLY</i>	50 ms
Relay 2 action	<i>Rct 2</i>	Automatic	Parity	<i>PAR itY</i>	Even
Relay 2 set point	<i>SEt 2</i>	2 FT0IN 0/16	Byte-to-byte timeout	<i>t-bytE</i>	010 (0.1 sec)
Relay 2 reset point	<i>rSt 2</i>	1 FT6IN 0/16	F1 function key	<i>F 1</i>	Reset max & min
Relay 3 action	<i>Rct 3</i>	Automatic	F2 function key	<i>F 2</i>	Big display: Max (Hi)
Relay 3 set point	<i>SEt 3</i>	3 FT0IN 0/16	F3 function key	<i>F 3</i>	Acknowledge relays
Relay 3 reset point	<i>rSt 3</i>	2 FT6IN 0/16	F4 function	<i>F 4</i>	Acknowledge relays
Relay 4 action	<i>Rct 4</i>	Automatic	Digital input 1	<i>d i 1</i>	Menu
Relay 4 set point	<i>SEt 4</i>	4 FT0IN 0/16	Digital input 2	<i>d i 2</i>	Right arrow
Relay 4 reset point	<i>rSt 4</i>	3 FT6IN 0/16	Digital input 3	<i>d i 3</i>	Up arrow
Fail-safe relay 1	<i>FLS 1</i>	Off	Digital input 4	<i>d i 4</i>	Enter
Fail-safe relay 2	<i>FLS 2</i>	Off	Digital output 1	<i>dO 1</i>	Alarm 1
Fail-safe relay 3	<i>FLS 3</i>	Off	Digital output 2	<i>dO 2</i>	Alarm 2
Fail-safe relay 4	<i>FLS 4</i>	Off	Digital output 3	<i>dO 3</i>	Alarm 3
On delay relay 1	<i>On 1</i>	0.0 sec			
Off delay relay 1	<i>OFF 1</i>	0.0 sec			
On delay relay 2	<i>On 2</i>	0.0 sec			
Off delay relay 2	<i>OFF 2</i>	0.0 sec			
On delay relay 3	<i>On 3</i>	0.0 sec			

Parameter	Display	Default Setting
Digital output 4	dD 4	Alarm 4
Password 1	PASS 1	000000 (unlocked)

Parameter	Display	Default Setting
Password 2	PASS 2	000000 (unlocked)
Password 3	PASS 3	000000 (unlocked)

Troubleshooting Tips

Symptom	Check/Action
No display at all	Check power at power connector
Not able to change setup or programming, LoCd is displayed	Meter is password-protected, enter correct six-digit password to unlock
Meter displays error message during calibration (Error)	Check: Signal connections Input selected in <i>Setup</i> menu Minimum input span requirements
Meter displays 999999 -999999	Check: Input selected in <i>Setup</i> menu Corresponding signal at Signal connector
Display is unstable	Check: Input signal stability and value Display scaling vs. input signal Filter and bypass values (increase)
Display response is too slow	Check filter and bypass values
Display reading is not accurate	Check: Signal input conditioner selected: Linear, square root, etc. Scaling or calibration
Display does not respond to input changes, reading a fixed number	Check: Display assignment, it might be displaying max, min, or set point.
Display alternates between H i and a number Lo and a number	Press Menu to exit max/min display readings.
Relay operation is reversed	Check: Fail-safe in <i>Setup</i> menu Wiring of relay contacts
Relay and status LED do not respond to signal	Check: Relay action in <i>Setup</i> menu Set and reset points
Flashing relay status LEDs	Relays in manual control mode or relay interlock switches opened.
Meter not communicating with application programs	Check: Serial adapter and cable Serial settings Meter address and baud rate
If the display locks up or the meter does not respond at all	Cycle the power to reboot the microprocessor.
Other symptoms not described above	Call Technical Support for assistance.

Note: Certain sequences of events can cause unexpected results. To solve these issues, it is best to start fresh from factory defaults and map changes ahead of time, rather than at random.

This Page Intentionally Left Blank

How to Contact Precision Digital

- For Technical Support, please
Call: (800) 610-5239 or (508) 655-7300
Fax: (508) 655-8990
Email: support@predig.com
- For Sales Support or to place an order, please
contact your local distributor or
Call: (800) 343-1001 or (508) 655-7300
Fax: (508) 655-8990
Email: sales@predig.com
- For the latest version of this manual, please visit
www.predig.com

Order from: **C A Briggs Company**
622 Mary Street; Suite 101; Warminster, PA 18974
Phone: 267-673-8117 - Fax: 267-673-8118
Sales@cabriggs.com - www.cabriggs.com

PRECISION DIGITAL CORPORATION

233 South Street • Hopkinton MA 01748 USA
Tel (800) 343-1001 • Fax (508) 655-8990



www.predig.com