

PD6720

Vantageview Loop-Powered Rate/Totalizer



 vantageview

FLOW RATE/TOTAL

- 4-20 mA Input Loop-Powered
- Modern, Sleek and Practical Enclosure for Safe Areas
- 5-Digit, 0.7" (17.8 mm) Upper Display
- 7 Alphanumeric Character, 0.4" (10.2 mm) Lower Display
- 7-Digit Totalizer
- SafeTouch® Through-Window Button Programming
- Password Protection
- 32-Point, Square Root, or Exponential Linearization
- Rate in Units per Second, Minute, Hour, or Day
- Open Collector Pulse or Alarm Output
- Loop or External DC-Powered Backlight Standard
- 3.0 V Drop (6.0 V with Backlight)
- NEMA 4X, IP65 Plastic Enclosure
- Flanges for Wall or Pipe Mounting
- HART® Protocol Transparent
- Operates from -40 to 75°C

Through-Window
Button Programming

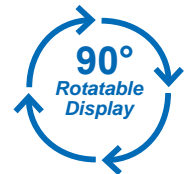

PRECISION DIGITAL CORPORATION

**PRECISION
DIGITAL** 
www.CABriggs.com

PD6720 Analog Input Rate/Totalizer

Displays rate & total simultaneously



Rate/Totalizer Displays



Flow Rate Indicator



Flow Totalizer



Rate & Total

Easy to Setup



Programming



OVERVIEW

The Vantageview PD6720 is a plastic field mounted loop-powered meter fully featured for demanding applications in wet or dirty environments. The meter derives all of its power from the 4-20 mA loop. It is programmed using the four SafeTouch® through-window buttons, without removing the cover, and can be scaled with or without a calibration signal. The numeric display will read up to 99999 and the alphanumeric display can be programmed to show any combination of numbers and letters up to seven characters long for use as engineering units and/or the process identification tag. The backlight lets you see the display under any lighting condition and can be powered from either the 4-20 mA loop or from a separate DC power supply.

KEY FEATURES

Informative & Easy to Read Display

The high contrast, backlight LCD display is easy to read from far away and under various lighting conditions. The upper display is 0.7" high and shows 5 digits of flow rate. The lower display is 0.4" high and shows either flow total or a tag with 7 alphanumeric characters. And best of all, the display is mounted right up against the glass so it can be seen from a wide viewing angle.

Through-Window SafeTouch® Buttons

The PD6720 is equipped with four sensors that operate as through-window buttons so that it can be programmed and operated without removing the cover (and exposing the electronics) in an industrial area. These buttons can be disabled for security by selecting the LOCK setting on the switch located on the connector board in the base of the enclosure. To actuate a button, press one finger to the glass directly over the marked button area. When the cover is removed, four mechanical buttons located next to the sensors are used.

Modern, Sleek and Practical Enclosure

The first thing customers notice about a product is its enclosure and the Vantageview really shines here. The injection-molded, protective NEMA 4X (IP65) enclosure is easy to install and mount. The built-in mounting flanges make for convenient wall or pipe mounting and there is even a slot on the back of the enclosure for centering on the pipe. There are three ¾" NPT conduit holes for wiring, and the enclosure allows for easy installation of tamper seals. The window and display module have been optimized to provide a wide viewing arc of approximately 80°, nearly twice that of the competition!



Wide Viewing Angle

Isolated Open Collector Output

The isolated open collector output on the PD6720 may be assigned for use with the alarm or totalizer (pulse output). The rating of the output is 30 VDC @ 150 mA max.

Perfect & Secure Fit Every Time

The internal rails ensure the Vantageview assemblies together perfectly, quickly and securely; and everything lines up for optimal viewing every time. There are no standoffs to worry about breaking or getting out of alignment. Two spring-loaded, self-retaining, thumbscrews make the assembly a snap, while pressing the LCD as close to the window as possible to improve wide angle viewing.

TOTALIZER CAPABILITIES

Totalizer Pulse Output

The totalizer pulse output function requires use of the open collector output. It will output a pulse at a user adjustable pulse rate, and can be scaled with a K-factor of between 0.0001 and 99999. Example: For 1 pulse every 500 gallons, set the K-factor to 500. This output can be sent to a PLC or counter.

Totalizer Conversion Factor

Total Conversion Factor is used to convert to a different unit of measure for the total display. For example, to display rate in gallons and total in liters, enter a conversion factor of 3.7854. When rate and total units are the same, the Conversion Factor should be 1.0000.

Total Reset

The total can be reset either manually via the front panel RESET button or external contact; or automatically using a programmed setpoint and delay time. Total reset can also be disabled.

INPUT SIGNAL CONDITIONING

Live Input Calibration

In lieu of meter scaling, the meter can be calibrated with a precision signal source. While applying a precision signal, the relative scale value is entered via the front panel. This is done at any two points along the scale. Using this method, the operator can set a “best fit straight line” for non-linear input spans.

Multi-Point Linearizer

Up to 32 linearization points can be selected under the Linear function. The multi-point linearization can be used to linearize the display for non-linear signals such as those from level transmitters used to measure volume in odd-shaped tanks or to convert level to flow using weirs and flumes that require a complex exponent. These points are established via direct entry (SCALE) or with an external calibration signal (CAL).

Square Root Extraction

The square root extraction function displays flow rate by extracting the square root from a differential pressure transmitter signal. The user selectable low-flow cutoff feature gives a reading of zero when the flow rate drops below a user selectable value.

Programmable Exponent

The programmable exponent function is used to linearize the level signal in open channel flow applications using weirs and flumes and display flow rate & total, units of measure, or toggle between total and units of measure.

ADDITIONAL FEATURES

Password Protection

A 5-digit password prevents unauthorized changes to the programmed parameter settings. The lock symbol is displayed to show that settings are protected. If the meter is password protected, the meter will display the message LOCKED when the Menu button is pressed.

Alarm Indication

The PD6720 can be configured to have a high or low rate alarm indicator, or a total alarm trip point indicator. The OC output is available for use as an alarm output. When in alarm mode, the display will flash, and a HI or LO symbol is displayed. The alarm has an adjustable deadband and is acknowledged by pressing the ENTER button.

INSTALLATION

Installation Flexibility

The PD6720’s rotatable display/meter module along with three available conduit connections provide for numerous installation options. The display can be rotated in 90° increments. Rotate it 90° for horizontal mounting. Wiring can then be routed to either the top conduit connection, or from below to the opposite conduit connection (plastic conduit plug supplied). Use the three conduit connections for through-wiring in any direction. Two 3/4” NPT plastic conduit plugs, with 1.29” wrenching flats and a screwdriver slot, are included.



Easy Wiring & Service

Unscrew the two captured thumb screws and unplug a connecting cable and the display/meter module is simply and completely removed. A heavy duty terminal block is then easily accessed and wired. It is clearly marked to prevent wiring errors. The display/meter module can be removed *without breaking the loop*. As such, it can be serviced without the need to uninstall the entire product.

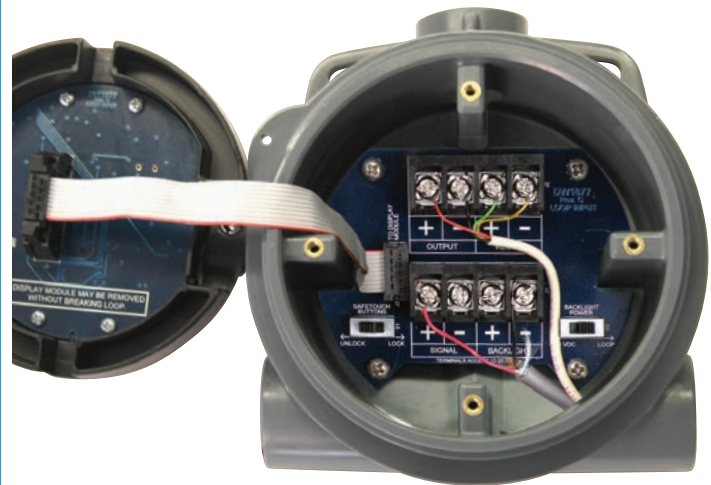

Internal View

CONNECTIONS

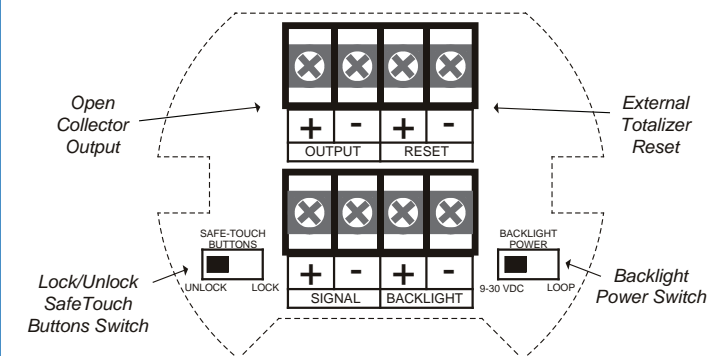

See LIM6720 manual for wiring instructions

SPECIFICATIONS

Except where noted all specifications apply to operation at +25°C.

general

Display: Upper: Five digits (-9,999 to 99,999) 0.70" (17.8 mm) high, 7-segment, automatic lead zero blanking. Lower: Seven characters 0.4" (10.2 mm) high, 14 segment alphanumeric. Symbols: for high & low alarm, password lock. Backlight: white

Display Update Rate: Ambient > -25°C: 2 Updates/Second.

Ambient < -25°C: 1 Update/5 Seconds

Externally Powered Backlight:

Voltage Range: 9-36 VDC

Supply Voltage	9 VDC	12 VDC	24 VDC	30 VDC
Maximum Power	0.2 W	0.25 W	0.5 W	0.75 W

Display Orientation: Display may be mounted at 90° increments up to 270° from default orientation.

Overrange: Display flashes 99,999

Underrange: Display flashes -9,999

Programming Method: Four SafeTouch® through-window buttons when cover is installed. Four internal pushbuttons when cover is removed.

Noise Filter: Programmable Lo, Med, Hi, or Off

Recalibration: Recalibration is recommended at least every 12 months.

Max/Min Display: Max/Min readings reached by the process are stored until reset by the user or until power to the meter is turned off.

Password: Programmable password restricts modification of programmed settings.

Advanced Functions: Linear, square root, or programmable exponent

Non-Volatile Memory: All programmed settings are stored in non-volatile memory for a minimum of ten years if power is lost.

Normal Mode Rejection: 64 dB at 50/60 Hz

Operating Temperature Range: -40 to 75°C.

Storage Temperature Range: -40 to 75°C.

Relative Humidity: 0 to 90% non-condensing

Connections: Screw terminals accept 12 to 22 AWG wire

Enclosure: NEMA 4X, IP65 plastic field enclosure. Color: grey. Material: Polycarbonate with UV Stabilizer. Three ¾" NPT threaded conduit openings. Two ¾" NPT plastic conduit plugs, with 1.29" wrenching flats and a screwdriver slot, are included.

Mounting: May be mounted directly to conduit. Two slotted flanges for wall mounting or NPS 1½" to 2½" or DN 40 to 65 mm pipe mounting.

Overall Dimensions: 5.67" x 5.25" x 4.18" (W x H x D)

(144 mm x 133 mm x 106 mm)

Weight: 1.65 lbs (26.4 oz, 0.75 kg)

Warranty: 3 years parts and labor

Input

Input range: 4-20 mA

Accuracy: ±0.03% of calibrated span ±1 count, square root & programmable exponent accuracy range: 10-100% of calibrated span.

Temperature Drift: 50 PPM/°C from -40 to 75°C ambient

Decimal Point: User selectable decimal point

Calibration Range: An error message will appear if input 1 and input 2 signals are too close together. Input Range: 4-20 mA. Minimum Span Input 1 & Input 2: 0.10 mA

Maximum Voltage Drop: 3.0 VDC @ 20 mA without loop-powered backlight. 6.0 VDC @ 20 mA with loop-powered backlight

Equivalent Resistance: 150 Ω @ 20 mA without loop-powered backlight. 300 Ω @ 20 mA with loop-powered backlight

Input Overload: Over current protection to 2 A max.

Open Collector Output

Rating: Isolated open collector, 30 VDC @ 150 mA max.

Alarm Output: Assign as rate alarm or total alarm trip point.

Deadband: 0-100% FS, user selectable

Acknowledge: Front panel ENTER button resets output and screen indication.

Pulse Output K-Factor: K-factor programmable from 0.0001 to 99999.

Pulse Output Frequency: 2, 4, 8, 16, 32, 64, 128 Hz. Minimum pulse width: 3.9 ms @ 128 Hz. Maximum pulse width: 250 ms @ 2 Hz. Factory default pulse width: 31 ms @ 16 Hz

Rate/Totalizer

Rate Display: 0 to 99,999 leading zero blanking

Total Display: 0 to 9,999,999 leading zero blanking

Total Decimal Point: Up to six decimal places or none: d.dddddd, d.ddddd, d.dddd d.ddd, d.dd, d.d, or ddddddd

Lower Display Configuration: Can be programmed to display total, tag name/engineering units, or to alternate between them.

Totalizer: Calculates total based on rate, time base of second, minute, hour, or day, and field programmable multiplier; stored in non-volatile memory upon power loss.

Totalizer Reset: Via front panel SafeTouch® button, time delay, external contact closure, or protected

Total Conversion Factor: 0.000001 to 9,999,999

Totalizer Rollover: Display rolls over when display exceeds 9,999,999. Relay status reflects the displayed value.

Total Reset Delay: Programmable from 0 to 99,999 seconds

DIMENSIONS

Units: Inch (mm)

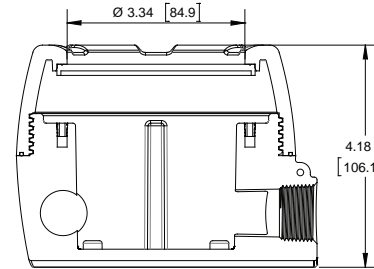
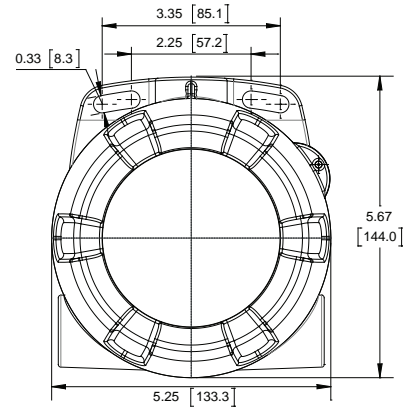

ORDERING INFORMATION

Vantageview PD6720 • Analog Input Rate/Totalizer

Model	Description
PD6720-0K1	Loop-Powered Rate/Totalizer with Backlight

your Local Distributor is:

Order from:

C A Briggs Company

622 Mary Street, Suite 101

Warminster, PA 18974

Phone: 267-673-8117 - Fax: 267-673-8118

Sales@cabriggs.com - www.cabriggs.com

Disclaimer

The information contained in this document is subject to change without notice. Precision Digital Corporation makes no representations or warranties with respect to the contents hereof, and specifically disclaims any implied warranties of merchantability or fitness for a particular purpose.

©2013-2016 Precision Digital Corporation. All rights reserved.

LDS6720_B 01/16