

SC100

INSTRUCTION MANUAL



Order from: **C A Briggs Company**
622 Mary Street; Suite 101; Warminster, PA 18974
Phone: 267-673-8117 - Fax: 267-673-8118
Sales@cabriggs.com - www.cabriggs.com

MOTOR PROTECTION ELECTRONICS

2464 Vulcan Road
Apopka, Florida 32703

Phone: (407) 299-3825
Website: www.mpelectronics.com

STATION CONTROLLER SC100

APPLICATIONS

- Simplex or Duplex Liquid Level Control
- Pump Down (Empty a Tank) or Pump Up (Fill a Tank)

STANDARD FEATURES

- 4 Digit, 7 Segment LED Level Display with Selectable Decimal Point Position
- All Setup Parameters Values may be viewed or changed from the front of the unit
- Analog Input AIX1 (4-20 mA) for connection of the Level Input from a Pressure Transducer
- Analog Output AOX1 (4-20 mA, Isolated) for re-transmitting the Level Input Signal
- Level Input Zero and Span Calibration Parameters for Field Calibration
- Provides +24VDC Power for Analog Level Input
- Two Pump Call Relay Outputs with Status Indication
- High and Low Level Alarm Relay Outputs with Status Indication
- 10 Second Power Up Delay (the first pump call is delayed by 10 seconds after a power interruption)
- Adjustable Lag Pump Delay for Pump Call Output
- Automatic Pump Alternation or Fixed Sequence: 1 - 2 or 2 - 1
- Level Simulation (Automatically ends after 60 seconds)
- Level Input Signal Conditioning Parameter (May be used to dampen out fluctuations in the Level Input Signal)
- Stores all Setup Parameter values in EEPROM (Does not require a backup battery)

SPECIFICATIONS

- Supply Power: 120 VAC \pm 10%, 7.8 VA max
- Enclosure Dimensions: 6.10" x 7.70" x 2.78" (H x W x D)
- Enclosure Material: Aluminum
- Faceplate Color: White with Blue Lettering
- Agency Approval: UL 508, CAN/CSA UL FILE #: E101681
- Ambient Operating Temperature: -20°C to +65°C (-4°F to +149°F)
- Storage Temperature: -45°C to +85°C (-49°F to +185°F)
- 4 Digit, 7 Segment LED Display Range: 0 - 2310 (Selectable Decimal Point Position)
- Indicators: Red LED
- Relay Outputs: 10A Resistive @ 120VAC
3.6A Inductive @ 120VAC
- Analog Input AIX1: 4-20 mA, Transient Protected, 100 Ω Load
- Analog Output AOX1: 4-20 mA, Transient Protected, Isolated
Maximum Load: 900 Ω
- Power for Analog Input: 24VDC, Overload and Transient Protected

ORDERING INFORMATION

Part Number: SC100

OPERATOR INTERFACE FUNCTIONS

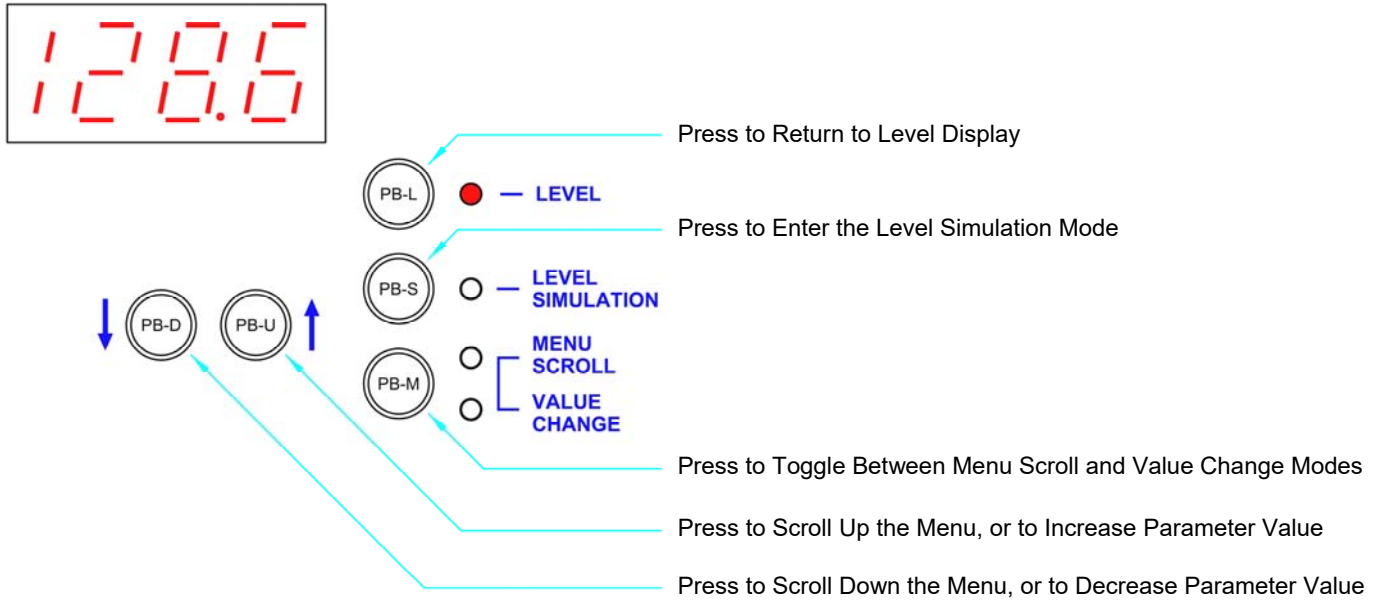

Note: To Prevent the Accidental Changing of a Parameter Value, there is a 4 second Delay Before a Parameter Value will Change.

(The PB-D or PB-U Push-Button must be Held Down for the Entire 4 second Delay.)

How to View a Setup Parameter Value

1. Press push-button PB-M until the Menu Scroll Mode indicator comes on.
2. Press push-button PB-D or PB-U as needed to arrive at the Parameter you wish to view.
3. Press push-button PB-M until the Value Change Mode indicator comes on.
4. The current value of the Parameter may then be viewed on the display.

How to Change a Setup Parameter Value

1. Press push-button PB-M until the Menu Scroll Mode indicator comes on.
2. Press push-button PB-D or PB-U as needed to arrive at the Parameter you wish to change.
3. Press push-button PB-M until the Value Change Mode indicator comes on.
4. The current value of the Parameter may then be viewed on the display.
5. Press and hold for 4 seconds, either push-button PB-D or PB-U, to change the Parameter to the desired new value.
6. Press push-button PB-M or PB-L to exit the Value Change Mode.

How to Simulate Levels

1. Press push-button PB-S.
Note: The Simulation starts from the actual level displayed prior to entering the Level Simulation mode.
2. Press push-button PB-D or PB-U as needed to change the simulated level.
3. To end the level simulation press push-button PB-L.
Note: If you do not exit the Level Simulation mode, normal operation will resume automatically 60 seconds after the last time the PB-U, PB-D, or PB-S push-buttons were pressed.

MENU - SYSTEM SETUP

Parameter	Default Value	Current Value	Setting Definitions
LoAL	2.0 feet		Low Level Alarm Range: 0.1 - 231.0
PoFF	3.0 feet		Pump Off Level Range: 0.2 - 231.0
1 Pon	6.0 feet		1st Pump On Level Range: 0.2 - 231.0
2 Pon	7.0 feet		2nd Pump On Level Range: 0.2 - 231.0
HIAL	10.0 feet		High Level Alarm Range: 0.5 - 231.0
			Note: Decimal Point Position for above Parameters is set by Parameter P - 21.
LAGd	5 sec.		Lag Delay Range: 1 - 100 seconds
ZERo	0.0 feet		Level Input Calibration - Zero Notes: 1. Parameter ZERo Shows the Level Input, while allowing the Up & Down Push-buttons to Change the Internal Number used to Zero the Displayed Value. 2. A 4.0mA signal must be applied to the Process Input while Setting the Zero. 3. Decimal Point Position is set by Parameter P - 21. See Page: 4.
SPAn	23.1 feet		Level Input Calibration - Span Range: 0.9 - 231.0 Notes: 1. Parameter SPAn allows the entry of the Transducer's Calibrated Span in feet. 2. A 20mA signal does not need to be applied to the Process Input while Setting the Span. 3. Decimal Point Position is set by Parameter P - 21. See Page: 4.
P - 13	2		Number of Pumps Present 1 = 1 Pump 2 = 2 Pumps
P - 19	1		Pump Up or Down Mode 1 = Pump Down - Empty a Tank 2 = Pump Up - Fill a Tank Note: When Parameter P - 19 is Changed New Default Pump On and Off Level Parameter Values will be loaded.
P - 20	0		Forced Lead Pump Position 0 = Normal Alternation 1 = Pump as 1 Lead 2 = Pump as 2 Lead
P - 21	1		Level Display Decimal Point Position 0 = No Decimal Point 1 = XXX.X 2 = XX.XX 3 = X.XXX
P - 22	240		Level Input Signal Conditioning Control Range: 1 - 254 10 = Very Slow 100 = Slow 240 = Normal 250 = Fast
P - 23	10 min.		Numerical Display Blanking Delay Range: 10 - 254 minutes Note: To disable the Numerical Display Blanking feature: Set Parameter P-23 = 255.
oPr	-		Operating Program Revision Number

High Level Alarm

- Upon a High Level Alarm, the indicator will come on, the relay will de-energize and the contacts will close.
- The High Level Alarm relay contacts will be closed when there is no power on the controller.

Low Level Alarm

- Upon a Low Level Alarm, the indicator will come on, the relay will energize and the contacts will close.
- The Low Level Alarm relay contacts will be open when there is no power on the controller.
- A Low Level Alarm is delayed for 10 seconds after power is applied.

LEVEL INPUT (4-20mA Input - AIX1) – CALIBRATION PROCEDURE

Notes:

1. Do not attempt to change the Zero calibration using the ZERo parameter without first applying a 4 mA signal to the Analog Level Input, or having a functioning Pressure Transducer (raised above the surface of the liquid) connected to the Level Input.
2. The rate of change of the displayed Level may be customized using Parameter P - 22.

LEVEL INPUT ZERO - Parameter ZERo

Parameter ZERo is used to make small changes to the Level Display Calibration to make the display read zero.

Calibration Procedure:

1. Apply a 4.0mA signal to the Analog Level Input.
(Alternate Procedure - Raise the pressure transducer up out of the liquid.)
2. Scroll in the menu to Parameter ZERo and press push-button PB-M to view the Level.
3. Press and hold down the “UP” or “DOWN” push-buttons as need to make the display read zero.
Note: It is slow to change at first.
4. Perform the procedure below to calibrate the Span.

LEVEL INPUT SPAN - Parameter SPAn

Parameter SPAn is used to enter the Transducer’s Calibrated Span in feet.

Calibration Procedure:

1. A 20mA signal **does not** need to be applied to the Level Input while Setting the Span.
2. Scroll in the menu to Parameter SPAn and press push-button PB-M to view the Parameter’s current value.
3. Press and hold down the “UP” or “DOWN” push-buttons as needed to make the display read the Transducer’s Calibrated Span.

LEVEL INPUT SPAN in Feet Of Water Versus TRANSDUCER CALIBRATION in PSI

		Transducer Calibration						
		5.0psi @ 20mA	10psi @ 20mA	15psi @ 20mA	30psi @ 20mA	60psi @ 20mA	100psi @ 20mA	
Level Input Span	-	-	-	-	139 feet	231 feet	P - 21 = 0	
	11.5 feet	23.1 feet	34.6 feet	69.3 feet	139.0 feet	231.0 feet	P - 21 = 1	
	11.50 feet	23.10 feet	-	-	-	-	P - 21 = 2	

Notes:

1. Parameter P - 21 is used to set the decimal point position.
2. To find the Span Setting for other transducers use the following equation:

$$\text{Pressure (psi)} \times 2.309 = \text{Level (feet of water)}$$

CONNECTION DIAGRAM

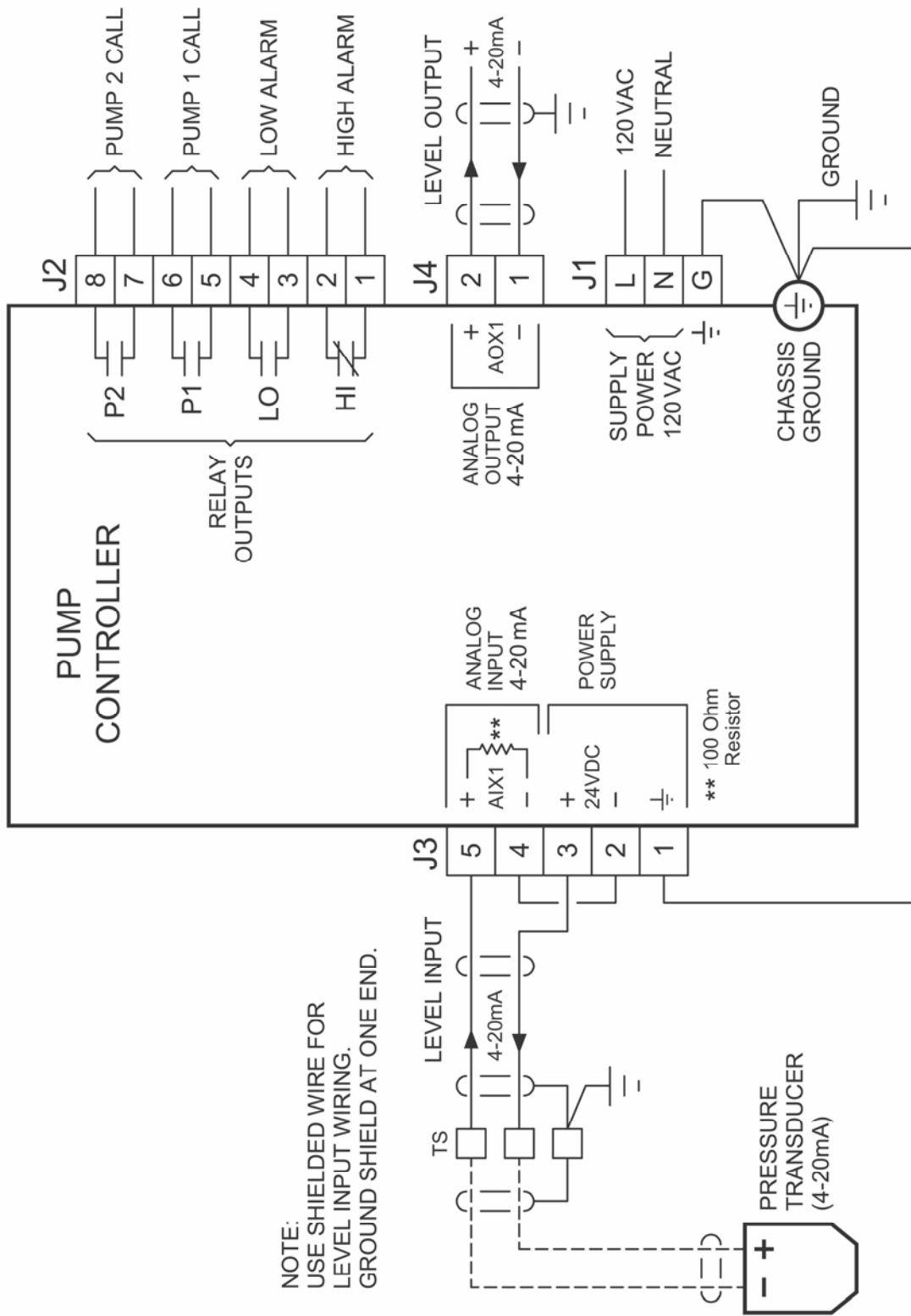

CONTROL SCHEMATIC EXAMPLE - Duplex with 24V Float Backup

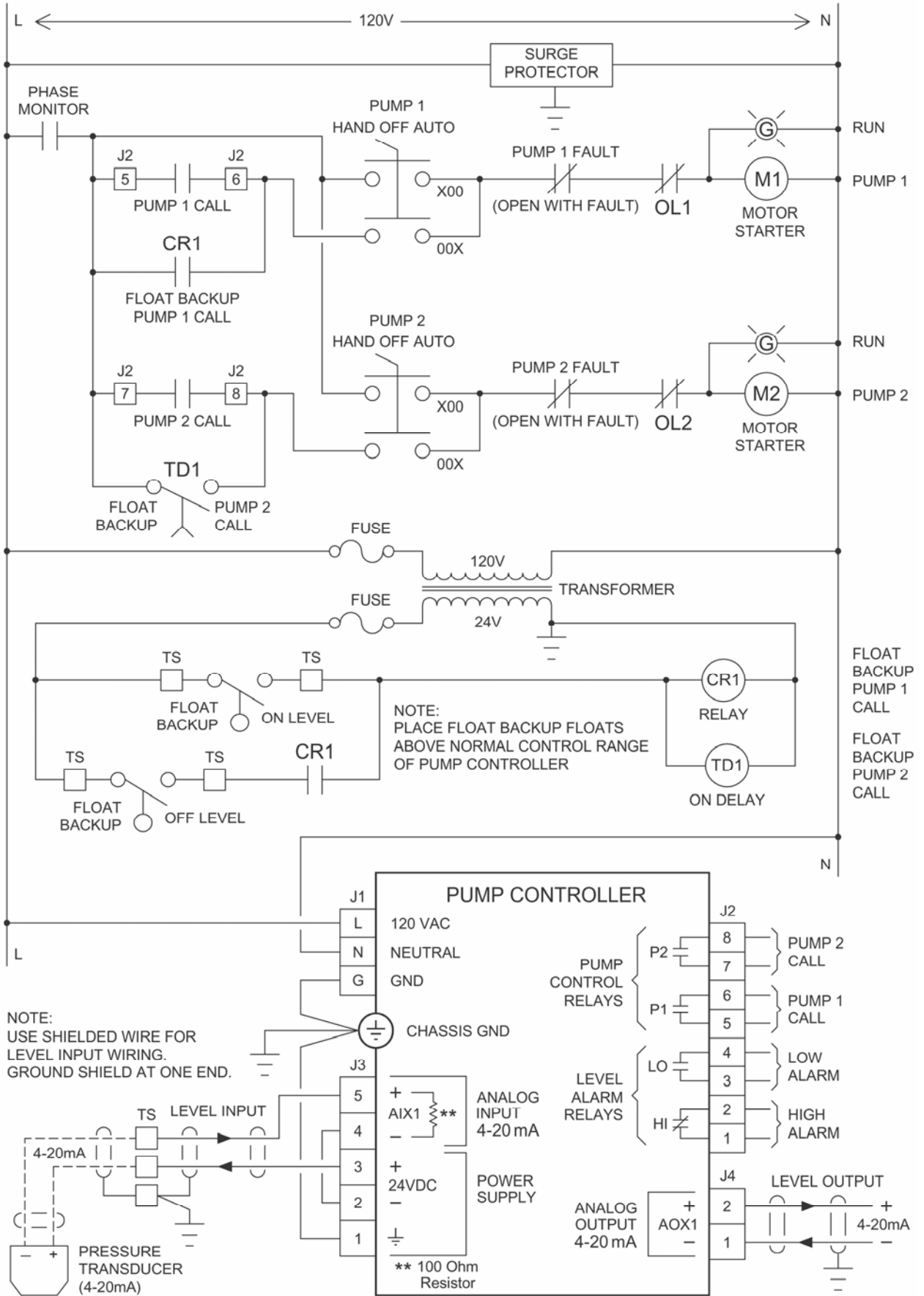

OPERATOR INTERFACE

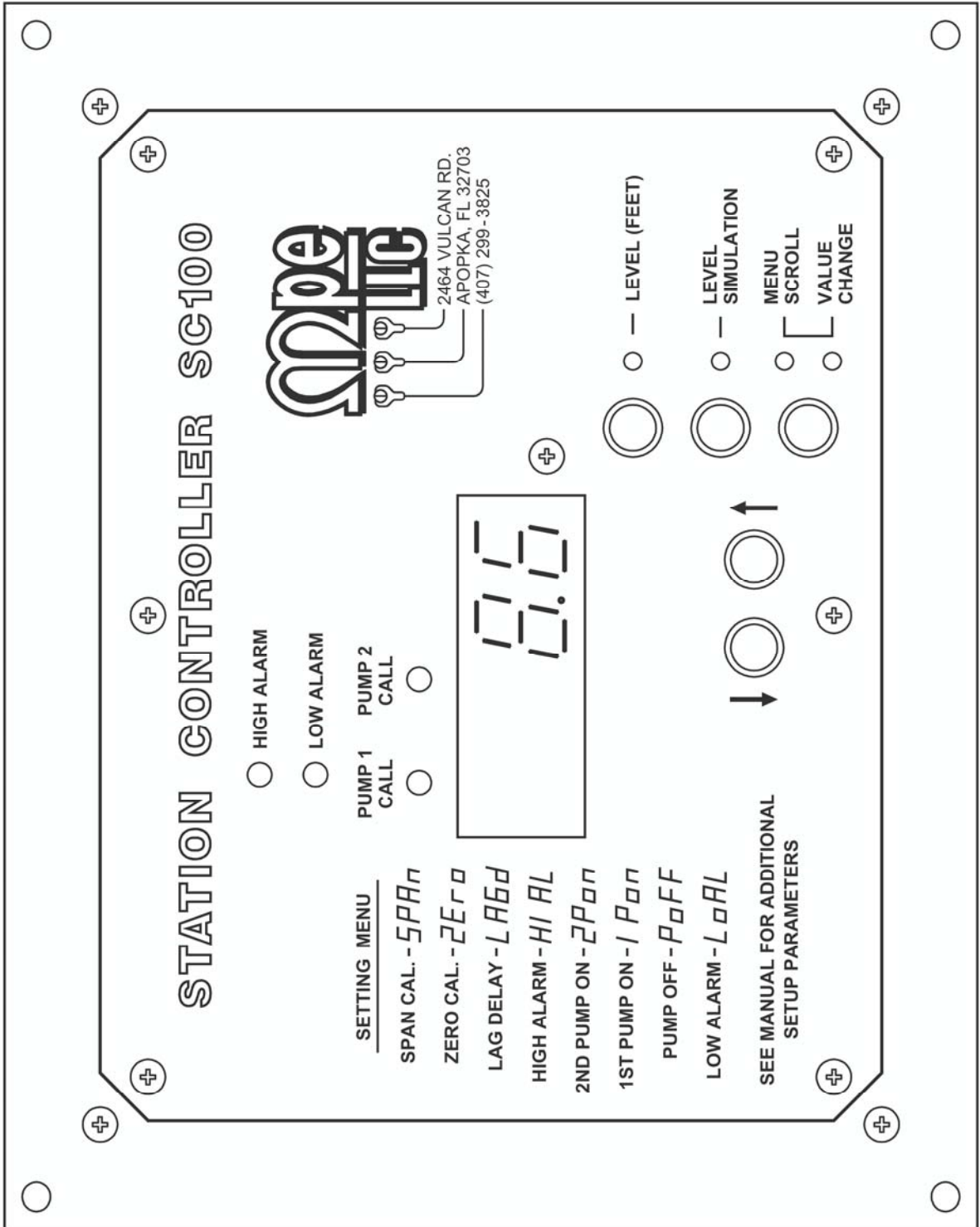

ENCLOSURE MECHANICAL LAYOUT

Left Side

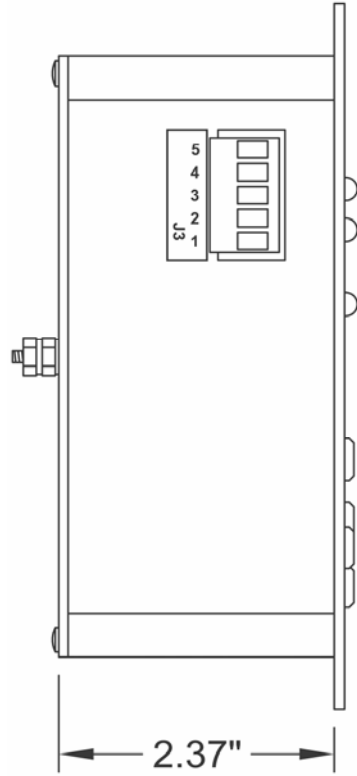

Right Side

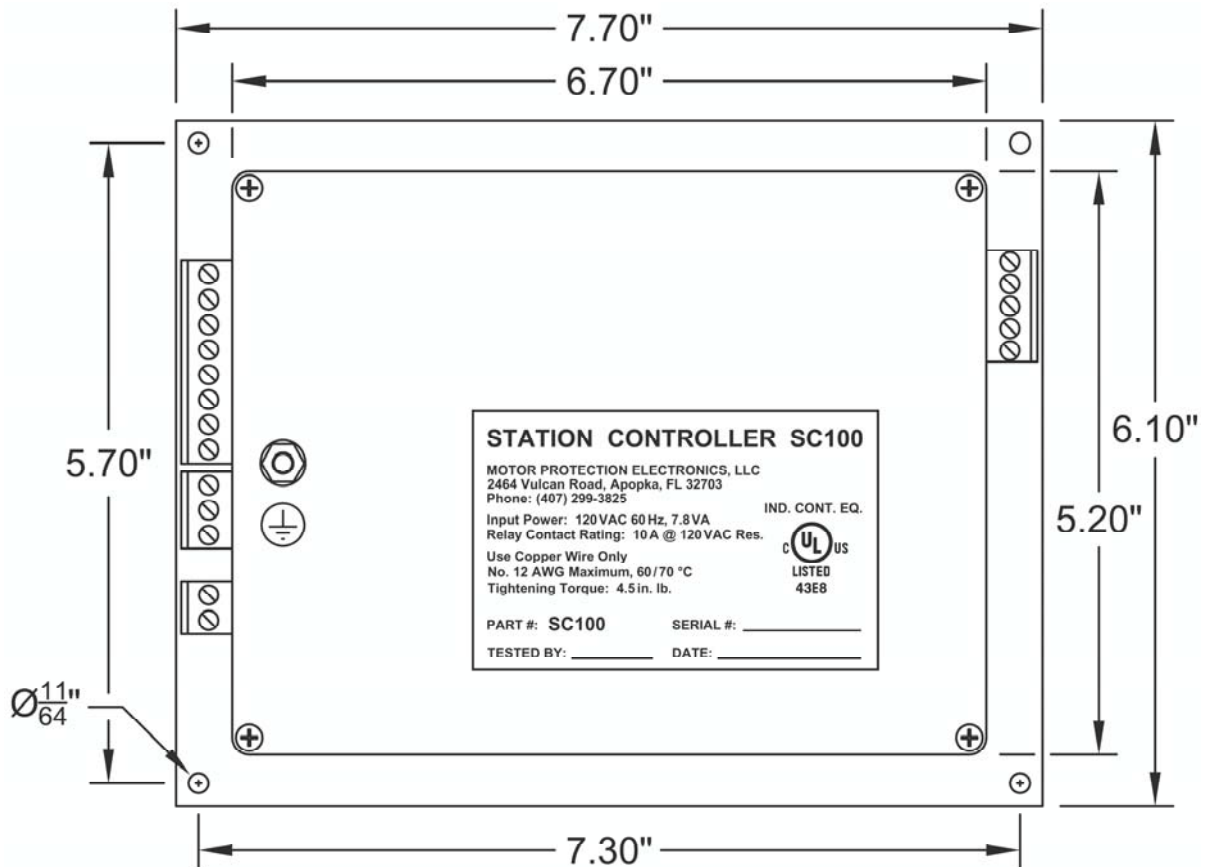
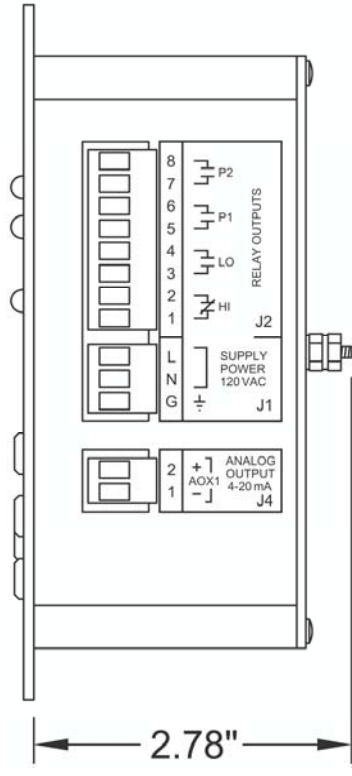

Rear View

PANEL CUTOUT

