

Bypass Level Measurement

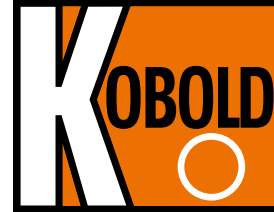

measuring
•
monitoring
•
analyzing

NBK-03, -06, -07, -10,
-31, -32

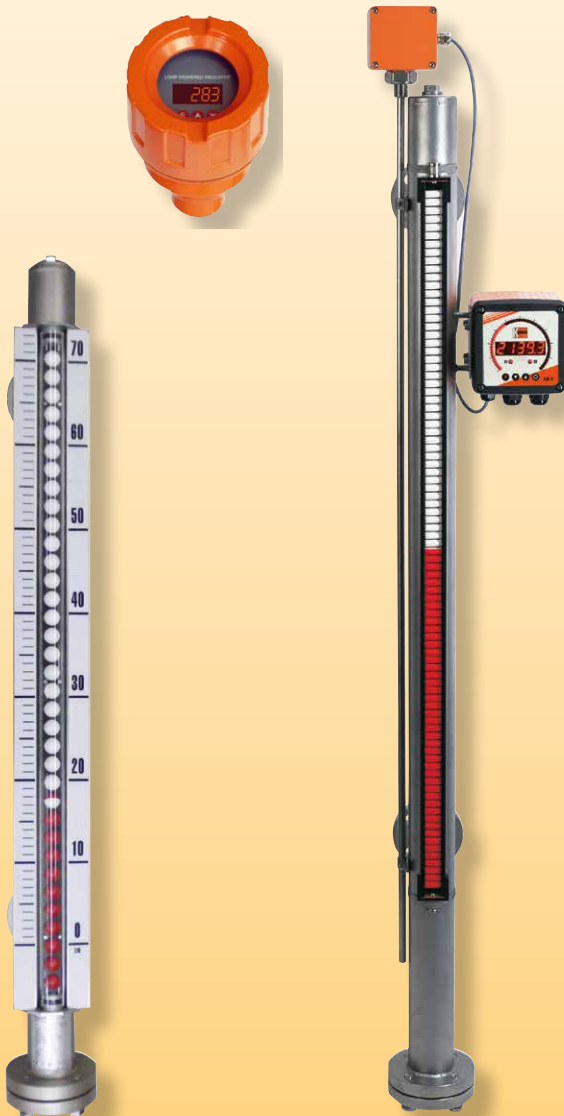

- Measuring Length: 18' Max over 18' Two-Part or Multipart
- Pressure: Max. Class 1500
- Temperature:
 - 40... 750 °F (Ceramic rollers)
 - 32 ... 250 °F (PP-rollers)
 - 155 ... 390 °F (Ball display)
- Viscosity: Max. 200 mm²/s Standard (Option: 460 mm²/s, only NBK-03)
- Connection:
 - ANSI Flange ½" ... 2"
 - NPT Threads ½" ... 1¼"
- Material: 316-Ti Stainless Steel
- Magnetically Coupled Magnet Roller or Ball Indicating Displays
- Limit Contacts
- Analog Output, HART®, PROFIBUS® PA, Foundation™ Fieldbus, & Digital Display Options



Order from: **C A Briggs Company**
622 Mary Street; Suite 101; Warminster, PA 18974
Phone: 267-673-8117 - Fax: 267-673-8118
Sales@cabriggs.com - www.cabriggs.com



Description

KOBOLD bypass level indicators are used for continuous measurement, display, and monitoring of liquid levels. The bypass tube is attached to the side wall of the tank. According to the laws of hydrostatic pressure, the level in the bypass tube will equal the level in the tank. A float, with embedded circular magnets, is located in the bypass tube and follows the liquid level, transferring the level in a non-contacting manner to a display attached to the outside of the bypass tube or to a sensing device.

The following indication and sensing devices are available:

Magnetic Roller Indicator

As the float passes by, the red/white rollers are rotated in succession by 180° around their own axes. The rollers change from white to red as the level rises and from red to white as the level falls. The advantage of ball display is the higher protection category, good visibility of 180° and higher vibration resistance with filled version. The level in a tank or a mixer is continuously displayed as a red column, even when the power fails.

Transmitter

To remotely sense the level, a transmitter with a chain of resistors or a magnetostrictive transducer can be mounted outside the bypass tube. A continuous standard signal of 4...20 mA is generated by means of a fitted transmitter. This standard signal can then be displayed on analog or digital indicating devices. Optionally, HART® PROFIBUS®-PA or Foundation™ Fieldbus communication protocols are possible.

Universal Indicating Unit

A universal indicating unit, series ADI-1, can be mounted on the bypass tube to display and evaluate the standard signal (4...20 mA) generated by the transmitter.

Limit Contacts

One or more reed contacts, for point level sensing or for level control, can be mounted to the bypass tube.

Applications

- Storage tanks
- Tanks on ships
- Agitator vessel
- Water tanks

Technical Details

Process Connection:	Flange ASME B 16.5 RF-2009 1/2", 3/4", 1", 1 1/4", 1 1/2", 2" NPT ANSI/ASME B1.20.1 1/2", 3/4", 1", 1 1/4"
Bypass Tube:	Ø 2.374", 316-Ti SS (NBK-03/.../10) Ø 2.8", 316-Ti SS (NBK-31/32) Flat gasket: <390 °F; PTFE, ≥390 °F, Klinger SIL®
NBK-03/06/07:	Reinforced graphite RTJ-seal
NBK-10:	ANSI 150/300/400/600/900/1500 PN 16/40/63/100/160/250/320
NBK-31/32:	32...250 °F (PP-rollers) -40...750 °F (ceramic rollers) -155...390 °F (ball display) (With NBK-31/32, the operating temperature is restricted to 212 °F)
Operating Pressure:	Max. 200 mm ² /s standard (Option: up to max. 460 mm ² /s for NBK-03)
Operat. Temperature:	18' over 18', two-part or multipart See dimensional drawing
Viscosity:	See separate description
Max. Meas. Length:	
Overall Length:	
ATEX- and GL-Approval:	
Roller Display RP	(max. continuous length 18')
Roller Material:	Polypropylene
Display Glass:	Plexiglas®
Carrier Frame Material:	Aluminum, anodized
Operat. Temperature:	32...250 °F
Protection:	IP 54
Roller Display RK	(max. continuous length 18')
Roller Material:	Ceramic
Display Glass:	Borosilicate glass
Carrier Frame Material:	Aluminum, anodized
Operat. Temperature:	-40...750 °F
Protection:	IP 54
Ball Display - Model KP	(max. continuous length 12.5')
Ball Material:	Ultramid™
Sight Tube:	Plexiglas®
Sealing Plug:	Aluminum
Seal:	Perbunan
Ball Support Rail:	Aluminum, anodized



Carrier Frame: 304 stainless steel
Scale: Hard-PVC,
 304 stainless steel (Option MV)
Operat. Temperature: -4 ... 175 °F
Protection: IP 66

Ball Display - Model KM (max. continuous length 9.8')
Ball Material: Ultramid B™
Sight Tube: Makrolon®
Sealing Plug: Aluminum
Seal: FKM
Ball Support Rail: Aluminum, anodized
Carrier Frame: 304 stainless steel
Scale: Hard-PVC,
 304 stainless steel (Option MV)
Operat. Temperature: -75 ... 250 °F
Protection: IP 66

Ball Display - Model KF (max. continuous length 12.5')
Filling: Silicone oil
Ball Material: Ultramid B™
Sight Tube: Makrolon®
Sealing Plug: 304 stainless steel
Seal: FKM
Ball Support Rail: Aluminum, anodized
Carrier Frame: 304 stainless steel
Scale: Hard-PVC,
 304 stainless steel (Option MV)
Operat. Temperature: -155 ... 250 °F
Protection: IP 66

Ball Display - Model KG (max. continuous length 9.8')
Material Ball: Ultramid B™
Sight Tube: Borosilicate glass
Sealing Plug: 304 stainless steel
Seal: FKM
Ball Support Rail: Aluminum, anodized
Carrier Frame: 304 stainless steel
Scale: 304 stainless steel
Operat. Temperature: -4 ... 390 °F
Protection: IP 66

Limit Contacts - Model NBK-R

Contact Operation: Bistable SPDT contact
Switching Hysteresis: Approx. 15 mm
Max. Switching Capacity: 60 W/VA, 230 V_{AC/DC}, 1 A
Resistance: 100 mΩ
Media Temperature: -40...212 °F
Ambient Temperature: -40... 165 °F
Connection: 3 m PVC-cable
Housing: Polycarbonate
Protection: IP 67

**Limit Contact High Temperature - Model NBK-RT200/
 NBK-RT400**

Contact Operation: Bistable SPDT contact
Switching Hysteresis: approx. 15 mm
Max. Switching Capacity: 80 VA, 250 V_{AC/DC}, 1 A
Resistance: <20 mΩ
Media Temperature: -40...390 °F/750 °F
Ambient Temperature: -40...290 °F/660 °F
Housing: Aluminum pressure-cast,
 terminal connection
Cable Entry M16 x 1.5, brass nickel-plated
Protection: IP 65

Limit Contact - Model NBK-RV200NO

Sensor Type: Reed contact
Switching Pattern: Normally open, bistable
Switching Hysteresis: Approx. 7 mm
Media Temperature: -155... 390 °F
Ambient Temperature: -40...160 °F
Max. Housing Temperature: 175 °F
Max. Operating Voltage U_{max}: 400 V_{DC} / 250 V_{AC}
Max. Load Current I_{max}: 0.5 A
Max. Switching Power P_{max}: 5 W
Housing: Aluminum pressure-cast,
 terminal connection
Protection: IP 65

Limit Contact - Model NBK-RV200NC

Sensor Type: Reed contact
Switching Pattern: Normally closed, bistable
Other Parameters: Same as NBK-RV200NO

* In case of multi-part design, a display (ball) length of 1.3" is not readable

Limit Contact - Model NBK-RN200NO

Sensor Type: NAMUR contact
Switching Pattern: Normally open, bistable
Max. Operating Voltage
U_{max}: 15 V_{DC}
R_{on}: 1 kΩ
R_{off}: 11 kΩ
Other Parameters: Same as NBK-RV200NO

Limit Contact - Model NBK-RN200NC

Sensor Type: NAMUR contact
Switching Pattern: Normally closed, bistable
Other Parameters: Same as NBK-RV200NO

Reed Contact Resistor Chain - Model ..W..

Total Resistance: 0.5 ... 5 kΩ
Meas. Circuit Voltage: Max. 24 V_{DC}
Measuring Current: Max. 0.1 A
Max. Length: 18"
Media Temperature: -40 ... 390 °F,
 -40 ... 750 °F with heat shield (option N)
Ambient Temperature: Max. 265 °F
Resolution: 0.4" (ML < 6.5')
 0.8" (ML ≥ 6.5')
Housing: Aluminum pressure-cast
Protection: IP 65

Reed Contact Resistor Chain with 2-Wire Transmitter - Model ..M

Output: 4 ... 20 mA
Supply Voltage: 16 ... 32 V_{DC}
Max. Length: 18"
Load: (U_B - 9 V) / 0.02 A [Ω]
Media Temperature: -40 °F ... 250 °F
Ambient Temperature: -24 °F ... 175 °F
Resolution: 0.4" (ML < 6.5')
 0.8" (ML ≥ 6.5')
Housing: Aluminum pressure-cast
Protection: IP 65

Reed Contact Resistor Chain with 2-Wire Transmitter: 4 ... 20 mA - Option ..MS

Like Model: ... M ... however with 100 mm thermal stand-off of connection head includes heat shield
Media temperature: -40 ... 570 °F

Reed Contact Resistor Chain with 2-Wire Transmitter, 4 ... 20 mA - Option MK

Like Model: ... M ... however with 16.4' silicone cable between connection box/Bypass
Media Temperature: -40 ... 750 °F

Magnetostrictive Sensor with 4-Wire Transmitter, 4 ... 20 mA - Model ..T..

Output: 4 ... 20 mA
Supply Voltage: 24 V_{DC}, max. 150 mA
Load: Max. 500 Ω
Max. Length: 13.1'
Media Temperature: -40 ... 250 °F
Ambient Temperature: -4 ... 175 °F
Accuracy: ±1 mm
Housing: Aluminum pressure-cast
Protection: IP 65

Reed Contact Resistor Chain with 2-Wire Transmitter, 4 ... 20 mA - Model A (Only with Display Options AE or AC)

Transmitter Model: 5333D
Common Specifications:
Power Supply: 8.0 ... 35 V_{DC}
Communication
Interface: Loop Link
Linear Resistance Input: 0 ... 10 kΩ
Current Output:
Signal Range: 4 ... 20 mA
Min. Signal Range: 16 mA
Updating Time: 135 ms
Load Resistance: ≤ (V_{supply} - 8) / 0.023 [Ω]
Sensor Error Detection:
Programmable: 3.5 ... 23 mA
Media Temperature: -40 ... 250 °F
 (with option N up to 480 °F)
Ambient Temperature: -4 ... 175 °F
Resolution: 0.4" (ML < 6.5')
 0.8" (ML ≥ 6.5')
Housing: Aluminum pressure-cast
Cable Entry: M 20 x 1.5
Protection: IP 66
LED or LCD Display (Options AE/AC):
Power Supply: Loop-powered
Voltage: LED 3.3 V at 4 mA
 3.7 V at 20 mA
 LCD max. 2.5 V



**Reed Contact Resistor Chain with 2-Wire Transmitter,
4...20 mA, HART® - Model H and Display Options HE
or HC**

Transmitter Model: 5335A
Common Specifications:
Power Supply: 8.0...35 V_{DC}
Communication Interface: Loop Link 5905A and HART®
Linear Resistance Input: 0...7 kΩ
Current Output:
Signal Range: 4...20 mA
Min. Signal Range: 16 mA
Updating Time: 440 ms
Load Resistance: $\leq (V_{\text{supply}} - 8) / 0.023 [\Omega]$
Sensor Error Detection:
Programmable: 3.5...23 mA
Media Temperature: -40...250°F (with Option N up to 480°F)
Ambient Temperature: -4...175°F
Resolution: 0.4" (ML<6.5')
 0.8" (ML≥6.5')
Housing: Aluminum pressure-cast
Cable Entry: M 20 x 1.5
Protection: IP66
LED or LCD Display (Options HE/HC):
Power Supply: Loop-powered
Voltage Drop: LED 3.3 V at 4 mA
 3.7 V at 20 mA
 LCD max. 2.5.V

**Reed Contact Resistor Chain with Transmitter,
- Model F (PROFIBUS®-PA, FOUNDATION™ Fieldbus)**

Transmitter Model: 5350A
Common Specifications:
Supply Voltage: 9...32 V_{DC}
Consumption: < 11 m
Isolation Voltage, Test / Operation: 1.5 kV_{AC} / 50 V_{AC}
Signal / Noise Ratio: min. 60 dB
Response Time (Programmable): 1...0 s
Updating Time: < 400 ms
Dimension: Ø 44 x 20.2 mm
Linear Resistance Input: 0...10 kΩ

Output:

FOUNDATION™ Fieldbus connection:
FOUNDATION™ Fieldbus Version: ITK 4.51
FOUNDATION™ Fieldbus Capability: Basic or LAS
FOUNDATION™ Fieldbus Function Blocks: 2 analog and 1 PID
PROFIBUS® PA Connection:
PROFIBUS® PA Protocol Standard: EN 50170 vol. 2
PROFIBUS® PA Function Blocks: 2 analog
PROFIBUS® PA Address (at Delivery): 126
Media Temperature: -40...250°F (with option N up to 480°F)
Ambient Temperature: -4...175°F
Resolution: 0.4" (ML<6.5')
 0.8" (ML≥6.5')
Housing: Aluminum pressure-cast
Cable Entry: M 20 x 1.5
Protection: IP66





Bypass Level Indicators Model NBK

Order Details (Example: **NBK-03 A15 RP 0 A 0**)

Model	Rated pressure	Connection	Nominal Size	Roller / Ball Indicator	Sensor / Transmitter	Media Density Float	Options
NBK-03...	Class 150 PN 16	A = ASME-flange F = DIN-flange N³⁾ = NPT-male thread R³⁾ = R-male thread S⁴⁾ = welding-nipple	15 = ½", DN 15 20 = ¾", DN 20 25 = 1", DN 25 32 = 1 ¼", DN 32 40 = 1 ½", DN 40 50 = 2", DN 50 XX = special connection ⁶⁾	00 = without RP = PP-roller RK = ceramic roller KP = ball display with Plexiglas sight tube KM = ball display with Makrolon® sight tube KF = as KM however with oil filling KG = ball display with borosilicate sight tube	0 = without transmitter T = magnetostrictive probe/ 4 ... 20 mA, 4-wire W = reed chain/ without M = reed chain/ 4 ... 20 mA, 2-wire A⁹⁾ = reed chain/ 4 ... 20 mA, 2-wire H = reed chain/ 4 ... 20 mA, HART®, 2-wire F = reed chain/ PROFIBUS® PA FOUNDATION™ Fieldbus	A = 1.0 kg/dm ³ , titanium for viscosity up to 200 cP B = 0.90 kg/dm ³ , titanium for viscosity up to 200 cP C = 0.80 kg/dm ³ , titanium for viscosity up to 200 cP D = 0.70 kg/dm ³ , titanium for viscosity up to 200 cP E = 0.60 kg/dm ³ , titanium for viscosity up to 200 cP F⁶⁾ = 0.54 kg/dm ³ , titanium for viscosity up to 200 cP V⁹⁾ = 1.0 kg/dm ³ , stainless steel for viscosity up to 460 mm ² /s W⁹⁾ = 0.8 kg/dm ³ , stainless steel for viscosity up to 460 mm ² /s	0 = without options or options as in list and description (see separate options list)
NBK-06...	Class 300 PN 40						
NBK-07...	Class 400 PN 63						
NBK-10...	Class 600 PN 100						
NBK-31 ⁷⁾	Class 900 PN 160						
NBK-32 ⁷⁾	Class 1500 PN 250						
NBK-R	standard limit contact (bistable SPDT contact)						
NBK-RT200	limit contact high-temperature max. 390 °F						
NBK-RT400	limit contact high-temperature max. 750 °F						
NBK-RV200NO	limit contact, bistable, N/O, max. 390 °F (suitable for tanks with strong vibrations)						
NBK-RV200NC	limit contact, bistable, N/C, max. 390 °F (suitable for tanks with strong vibrations)						
NBK-RN200NO	limit contact, bistable, NAMUR, N/O, max. 390 °F (suitable for tanks with strong vibrations)						
NBK-RN200NC	limit contact, bistable, NAMUR, N/C, max. 390 °F (suitable for tanks with strong vibrations)						

³⁾ female thread on request

⁴⁾ only possible with NBK-03/06 and nominal size 1", DN25

⁵⁾ only possible with NBK-03

⁶⁾ not possible with NBK-10

⁷⁾ only possible for ½", ¾" and 1" ASME DN 15 and DN 25 bzw.









⁸⁾ specify in clear text

⁹⁾ only with options AE and AC

*Additional Information Required for Order:

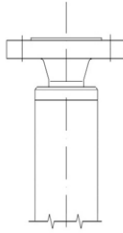
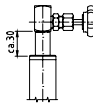
To ensure proper operation, this product requires a completed application guide form to be submitted with any order. Please refer to the 'documentation' tab on the bottom of the product page for this product on our website in order to obtain the correct form. You can also contact your KOBOLD representative for this form.

Options

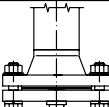
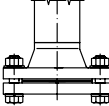
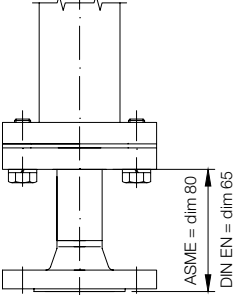
Code	Description	Drawing	Availability
Top Bypass Tube Connections			
V0	Without vent plug		for NBK-03/06/07, Standard for NBK-10/31/32
VN	With vent plug 1/2" NPT		for NBK-10/31/32, Standard for NBK-03/06/07
VA ^{1) 4)}	Flange connection 2" ASME (pressure rating as process flange)		NBK-03/06/07/10 NBK-31/32
VJ ^{1) 4)}	Flange connection DIN (pressure rating as process flange) with vent plug 1/2" NPT		NBK-03/06
V7 ⁴⁾	Vent flange 1/2" ASME, stainless steel 316Ti (pressure rating as process flange)		NBK-03/06
V8 ⁴⁾	Vent flange 3/4" ASME, stainless steel 316Ti (pressure rating as process flange)		NBK-03/06
V9 ⁴⁾	Vent flange 1" ASME, stainless steel 316Ti (pressure rating as process flange)		NBK-03/06
V2	Vent valve, 1/2" NPT, stainless steel 316Ti, max. temperature: 250 °F		NBK-03/06
Bottom Bypass Tube Connections			
D0	Without drain plug		NBK-03/06/07, Standard for NBK-10/31/32
DN	With drain plug 1/2" NPT	NBK-03/06  NBK-07/10 	NBK-10/31/32, Standard for NBK-03/06/07
DA	Flange connection 2" ASME (pressure rating as process flange), with drain plug 1/2" NPT		NBK-03/06
DD	Flange connection 2" ASME (pressure rating as process flange), without drain plug		NBK-03/06/07
E7	Drain flange 1/2" ASME, stainless steel 316Ti (pressure rating as process flange)		NBK-03/06
E8	Drain flange 3/4" ASME, stainless steel 316Ti (pressure rating as process flange)		NBK-03/06
E9	Drain flange 1" ASME, stainless steel 316Ti (pressure rating as process flange)		NBK-03/06

Options

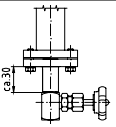
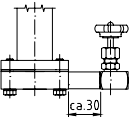
Code	Description	Drawing	Availability
F2	Drain valve, 1/2" NPT, stainless steel 316Ti, max. temperature: 250 °F		NBK-03/06
D2	Drain valve, 1/2" NPT, horizontally mounted, stainless steel 316Ti, max. temperature: 250 °F		NBK-03/06
Process Connection Options			
ST ⁴⁾	1 x process connection side, 1 process connection vertical on top	see drawing	NBK-03/06/07/10
TS ⁴⁾	1 x process connection side, 1 process connection vertical at bottom	see drawing	NBK-03/06/07/10
TT ⁴⁾	2 x process connection vertical, up to DN25 or 1" ASME	see drawing	NBK-03/06/07/10
Scales			
(Ball displays are always delivered with scales, see technical data/sketch for resolution)			
M2	Measuring scale, media temperature -40°F ... 300°F, scale backing made of aluminum laser etched	see drawing	NBK-03/06/07/10/31/32
M1	Measuring scale, media temperature -40 °F ... +750 °F, engraved scale made of aluminum	see drawing	NBK-03/06/07/10/31/32
MV	Scale made of 304 stainless steel (only with ball display model KP/KM/KF, standard with model KG)	see drawing	NBK-03/06/07/10/31/32
Thermal Screening			
N	Heat Shield for sensor	see drawing	NBK-03/06/07/10/31/32
Heating Jacket			
LA	Connection for heating jacket 1/2" Class 150 RF ASME B16.5-2003 (Class 300 flanges on request)	see drawing	NBK-03/06/07/10
LB	Connection for heating jacket 3/4" Class 150 RF ASME B16.5-2003 (Class 300 flanges on request)		NBK-03/06/07/10
LC	Connection for heating jacket 1" Class 150 RF ASME B16.5-2003 (Class 300 flanges on request)		NBK-03/06/07/10
LD	Connection for heating jacket 1 1/4" Class 150 RF ASME B16.5-2003 (Class 300 flanges on request)		NBK-03/06/07/10
Electrical Outputs			
MU	Option M with connection box at bottom, for easy access to connection box		NBK-03/06/07/10/31/32
MS	Option M including heat shield and connection box at 4" distance, max. media temperature = 570 °F		NBK-03/06/07/10/31/32
MK	Option M including heat shield and connection box 16.4' silicone cable, max. media temperature = 750 °F		NBK-03/06/07/10/31/32

¹⁾ not possible with transmitter options H/F

²⁾ with NBK-31/32 is flange connection always 2 1/2" ASME, as standard without drain plug or vent plug



³⁾ only possible with option T (magnetostrictive sensor or option M (reed chain with transmitter)

⁴⁾ not possible with option T

Note: Please pay attention to max. permissible temperature limits of individual components



Options

Code	Description	Drawing	Availability
Display Options			
AE	Aluminum die-cast housing, LED digital display, connection box at bottom (only in combination with transmitter option A)		NBK-03/06/07/10/31/32
AC	Aluminum die-cast housing, LCD digital display, connection box at bottom (only in combination with transmitter option A)	as AE, however with LCD display	NBK-03/06/07/10/31/32
HE	Aluminum die-cast housing, LED digital display, connection box at bottom (only in combination with transmitter option H)		NBK-03/06/07/10/31/32
HC	Aluminum die-cast housing, LCD digital display, connection box at bottom (only in combination with transmitter option H)	as HE, however with LCD display	NBK-03/06/07/10/31/32
C³⁾	Indicating unit ADI-1 with bargraph and digital display, rugged aluminium housing, mounted at bypass tube, for description see brochure Z2	see cover page / drawing	NBK-03/06/07/10/31/32
Additional Options			
A	Connection flange for 2-part version (not possible with sensor), split roller display and scale possible	see drawing	NBK-03/06/07/10/31/32
HL	Retaining plate, centric between process connections, necessary from L 16.4' (alternative option HF)	see drawing	NBK-03/06/07/10/31/32
HF	Retaining flange, centric between process connections, necessary from L > 16.4' (alternative option HL)	see drawing	NBK-03/06/07/10/31/32
K	Armaflex-insulation (heat co-efficient 0.025 kcal/m °C, to 220 °F)	-	NBK-03/06/07/10/31/32
Tests/Certificates			
P	Radiographic examination per DIN 54 111 T1	-	NBK-03/06/07/10/31/32
Q	Dye penetration test per DIN EN 571-1	-	NBK-03/06/07/10/31/32
X	Pressure test with water (1.5 x PN)	-	NBK-03/06/07/10/31/32
Z	3.1 Inspection Certificate per EN 10204	-	NBK-03/06/07/10/31/32
MR	Material acc. to NACE MR 0103/ISO15156 (MR0175), declaration of conformance	-	NBK-03/06/07/10/31/32
WV	Positive Material Identification (PMI)	-	NBK-03/06/07/10/31/32
SF	Oil and fat free	-	NBK-03/06/07/10/31/32

¹⁾ not possible with transmitter options H/F

²⁾ with NBK-31/32 is flange connection always 2½" ASME, as standard without drain plug or vent plug

³⁾ only possible with option T (magnetostrictive sensor or option M (reed chain with transmitter)

⁴⁾ not possible with option T

Note: Please pay attention to max. permissible temperature limits of individual components

Order from: **C A Briggs Company**

622 Mary Street; Suite 101; Warminster, PA 18974

Phone: 267-673-8117 - Fax: 267-673-8118

Sales@cabriggs.com - www.cabriggs.com

Drawings of Selected Options

Option DS

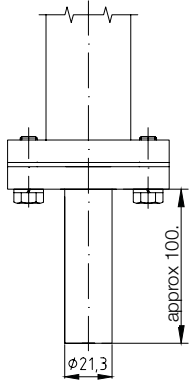

Option TT

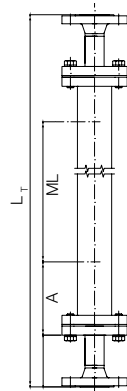

Option ST

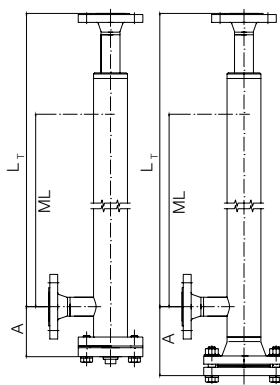

Option TS

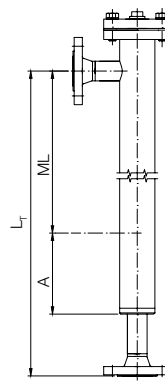

Option A

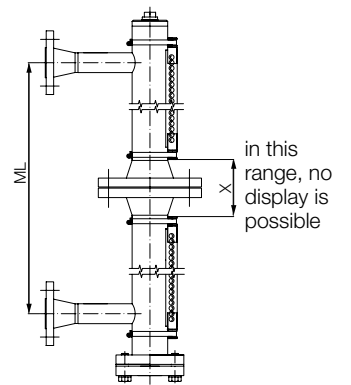

Option HL

(centered to dimens. L)

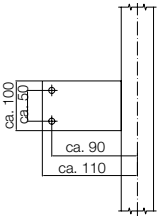

Option HF

(centered to dimens. L)

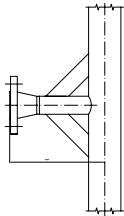

Options Process Connection

Option F/A

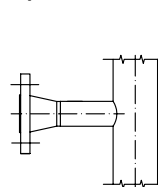

Option N/R

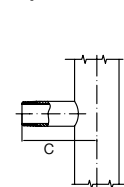

Option S

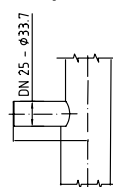

Model	Dimension X
NBK-03	92
NBK-06	98
NBK-07	127
NBK-10	139

Measuring Scale, Aluminum

- Option M1 - Engraved Scale
- Option M2 - Laser Etched

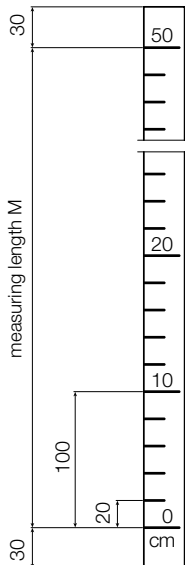

Measuring Scale Screen Print, Stainless Steel Carrier

(standard scope of supply with ball display)

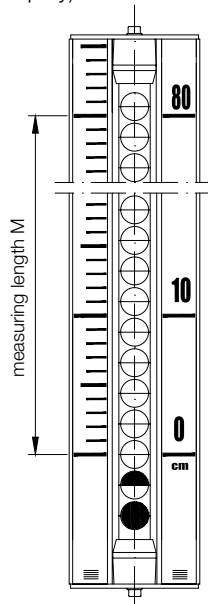

Float Options

Model	Min. Density [kg/dm³]	Material
A	1.0	titanium
B	0.9	titanium
C	0.8	titanium
D	0.7	titanium
E	0.6	titanium
F*	0.54	titanium
V	1.0	stainless steel
W	0.8	stainless steel
H	0.8	CF340
Interface Float	min. density difference = 150 kg/dm³ (indicate both densities)	titanium

*Heat Shield option N not possible and/or not for NBK-10.

Special floats for special media densities (weighting) or reduced length dimension A on request.

Dimensions

NBK-03/06/07 with Roller Indicator/Ball Display

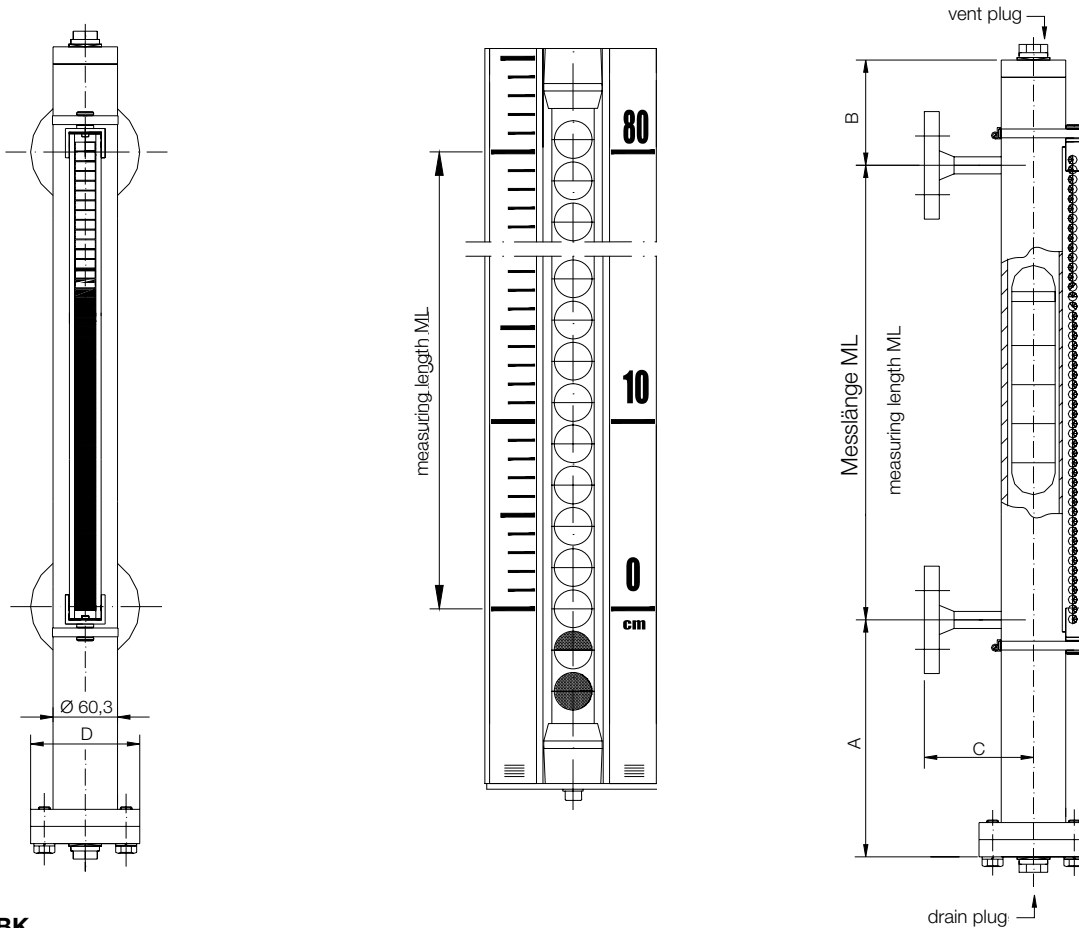

Dimension NBK

Model	Rated Pressure	Dimensions [mm]		
		B	C	D
NBK-03...	Class 150	130	110	115
NBK-06...	Class 300	130	110	115
NBK-07...	Class 400	130	150	180
NBK-10...	Class 600	130	150	195
NBK-31...	Class 900	150	180	244.3
NBK-32...	Class 1500	150	180	244.3

NBK 10/31/32

always without vent plug and without drain plug

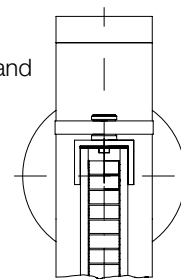

Clearance Dimension A [mm]

Model	Rated Pressure	Media Density					
		0.54 [kg/dm³]	0.6 [kg/dm³]	0.7 [kg/dm³]	0.8 [kg/dm³]	0.9 [kg/dm³]	1 [kg/dm³]
NBK-03...	Class 150	320	320	320	320	320	210
NBK-06...	Class 300	410	410	320	320	320	210
NBK-07...	Class 400	410	410	320	320	320	210
NBK-10...	Class 600	-	700*	410**	320	320	210
NBK-31...	Class 900	-	-	-	540	415	345
NBK-32...	Class 1500	-	-	-	540	415	345

* 800 for units with thermal screening; **450 at apparatus with thermal screening

No responsibility taken for errors; subject to change without prior notice.

NBK-31/32 with Roller Indicator/Ball Display

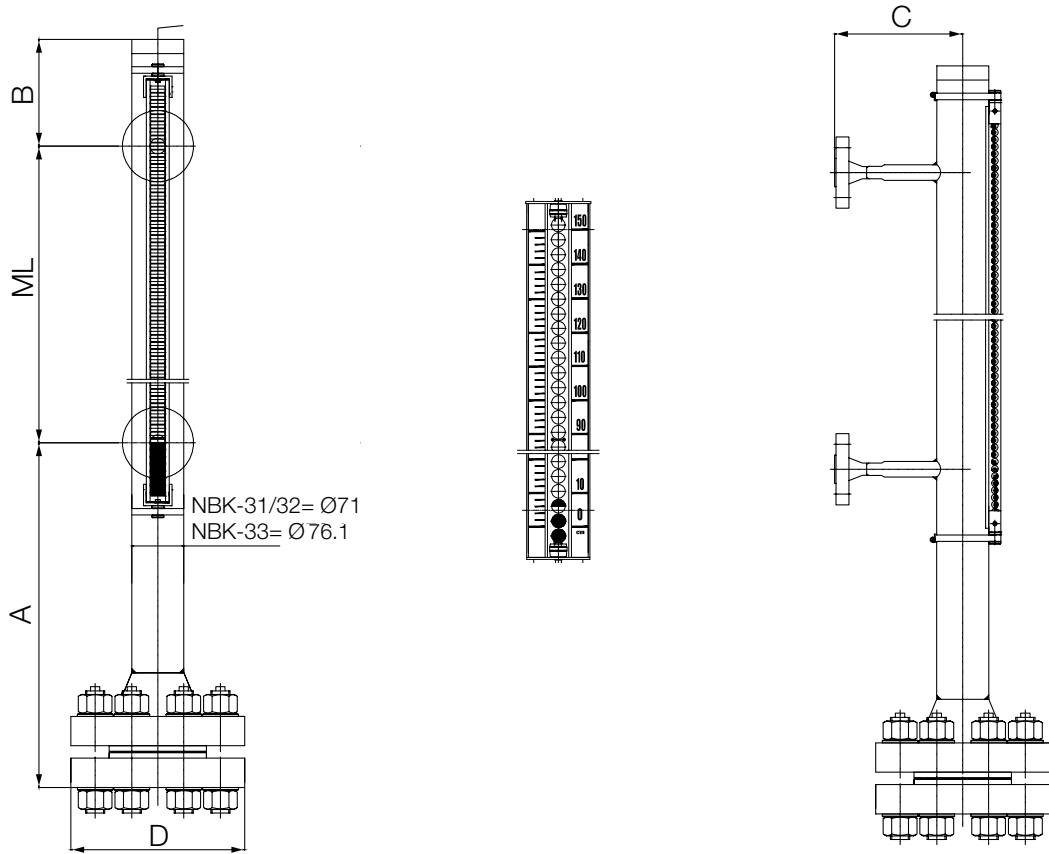

Pressure-Temperature-Assignment for Stainless Steel Flange

ASME B 16.5 RF-2009										
Flange Rating	Material	Maximum Temperature TS in °F								
		Ambient	200	300	400	500	600	700	750	
		Maximum Pressure PS in PSI								
150	316-Ti Stainless Steel	275	235	215	195	170	140	110	95	
300		720	620	560	515	480	450	435	425	
400		960	825	745	685	635	600	580	570	
600		1440	1240	1120	1025	955	900	870	855	
900		2160	1860							
1500		3600	3095							

Remarks:

Ambient = -20...100°F

TS = maximum allowable temperature in °F, temperature which is defined by pressure equipment manufacturer, for which the pressure equipment is designed

PS = maximum allowable pressure, pressure which is defined by pressure equipment manufacturer, for which the plant is designed. 316-Ti was calculated with help of creep resistance values of 100 000 h acc. to EN-Material Norms considering the safety value.

At intermediate temperatures e.g. 250 °F, a linear interpolation is to be carried out between 2 following creep resistance values, e.g. of 212 °F and 300 °F.

The pressure/temperature assignment is valid for the following flange models with sizes up to ASME Class 1500 used by KOBOLD.

NBK... with Reed Chain - Model W

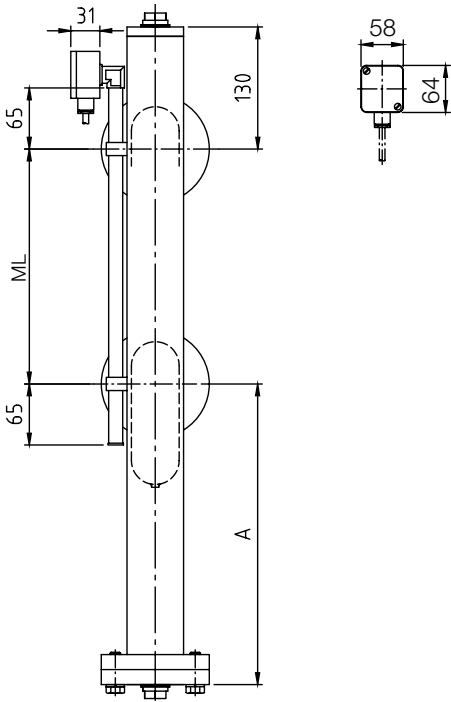

NBK... with Transmitter - Model M

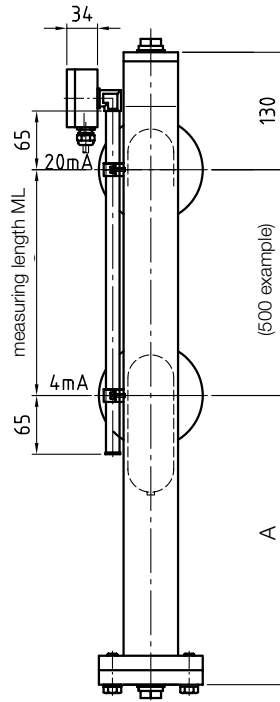

NBK... with Transmitter - Model T

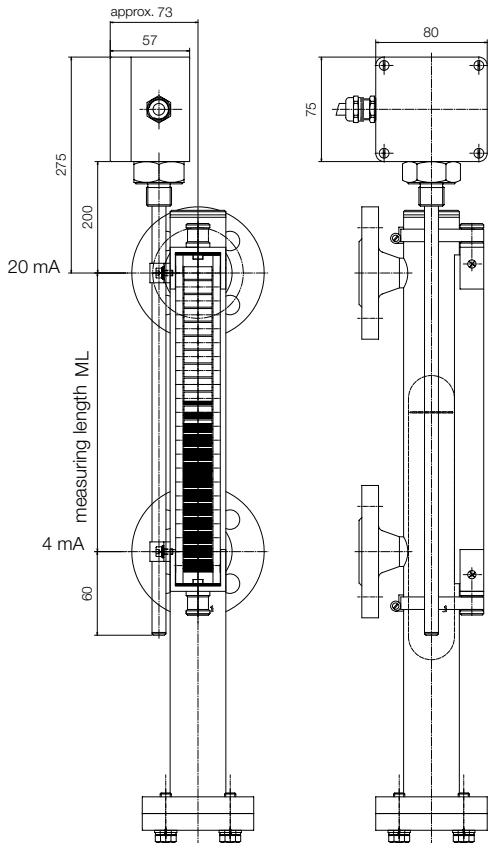

NBK... with Transmitter - Options H/F
(not possible with options VA/VF)

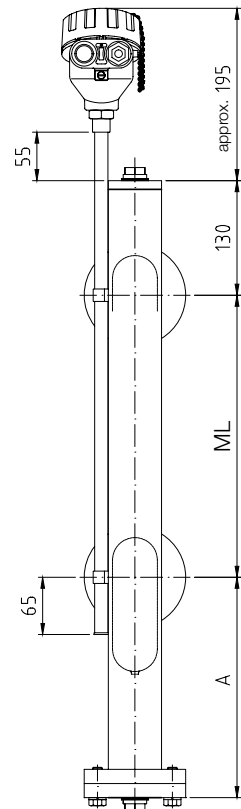

NBK... with Thermal Screen - Option N

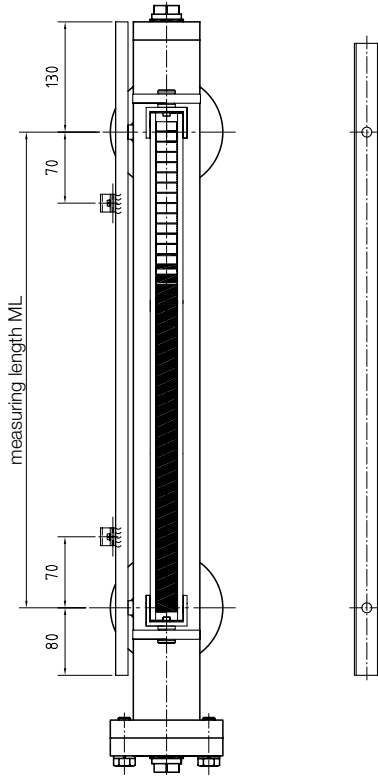

NBK... with Heating Jacket - Option LX

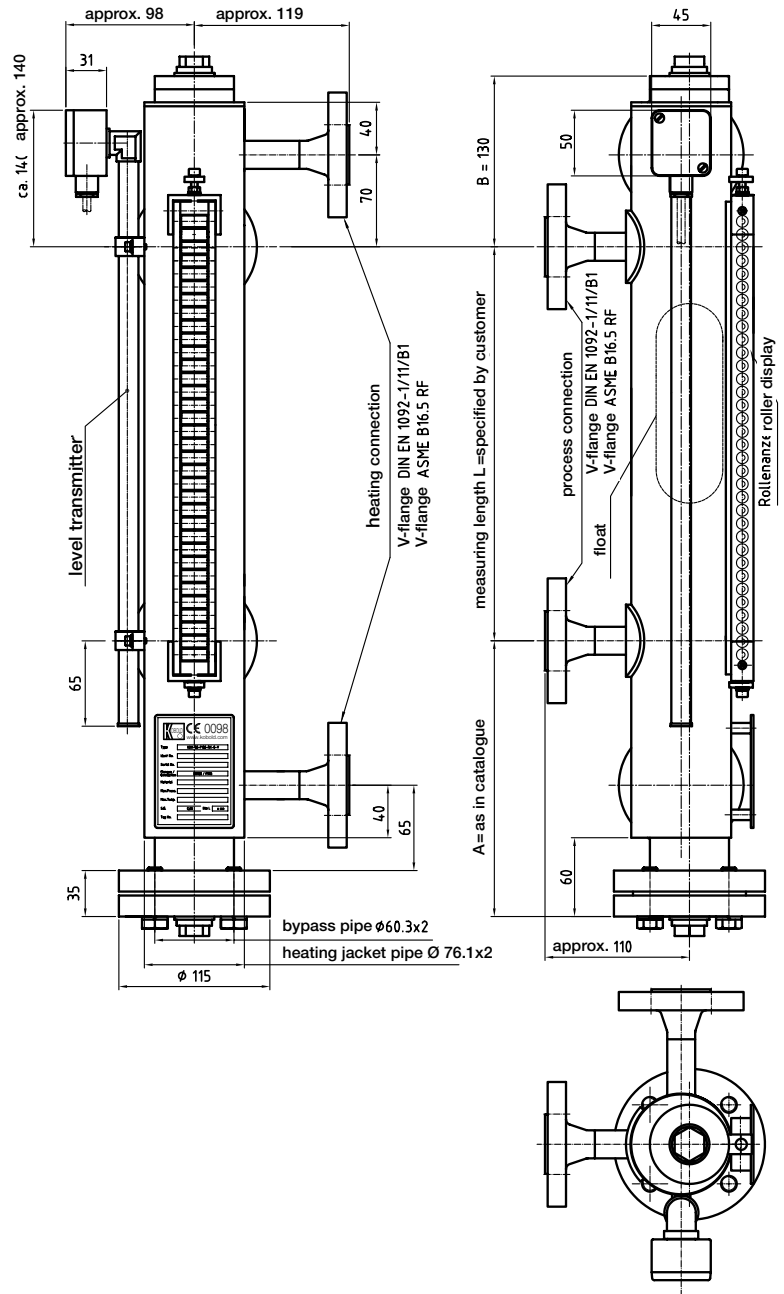

NBK... with Transmitter - Option MU

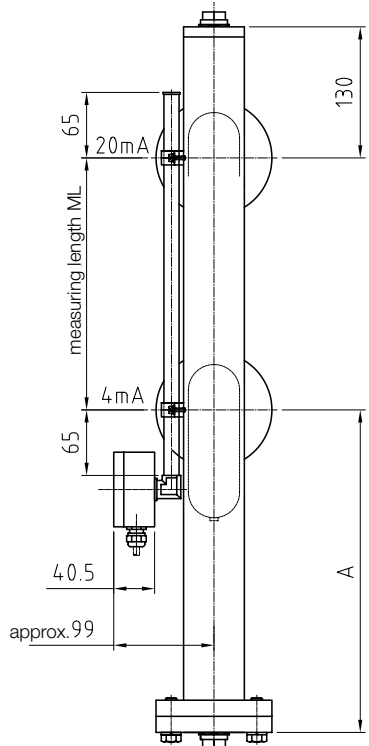

NBK... with Transmitter - Option MS

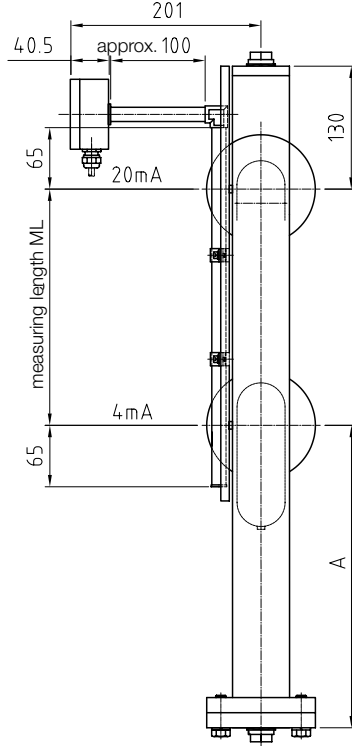

NBK... with Transmitter - Option MK

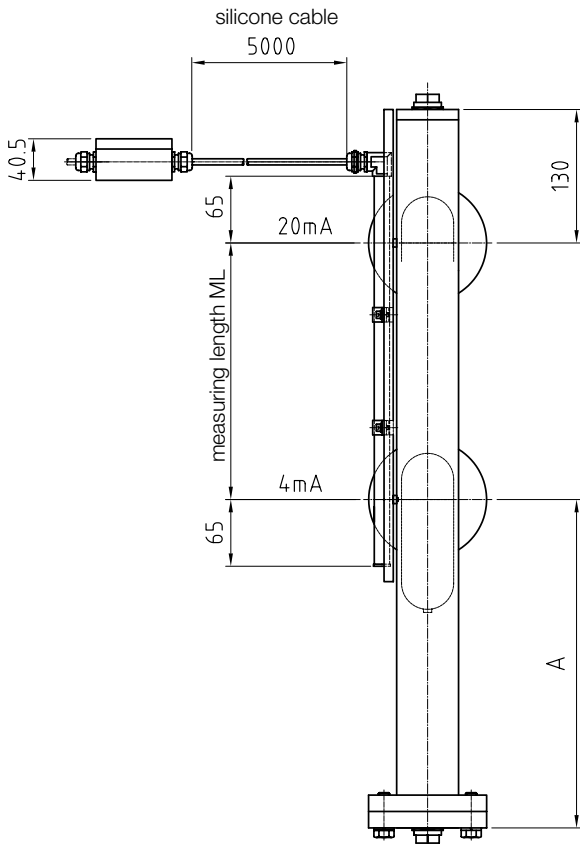

NBK... with Transmitter Display - Options AE/HE or AC/HC

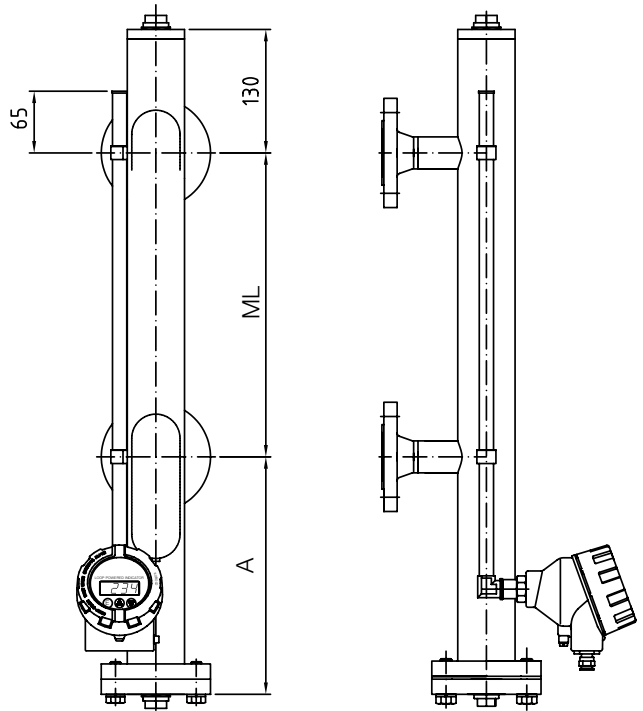

Process Connection - Option ST

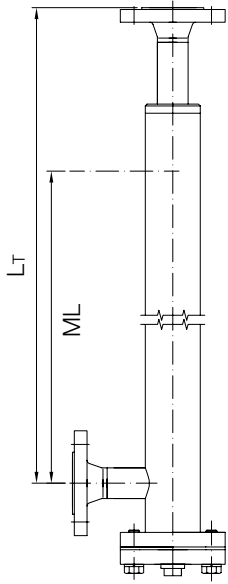

NBK... with Transmitter - Model M - Option ST

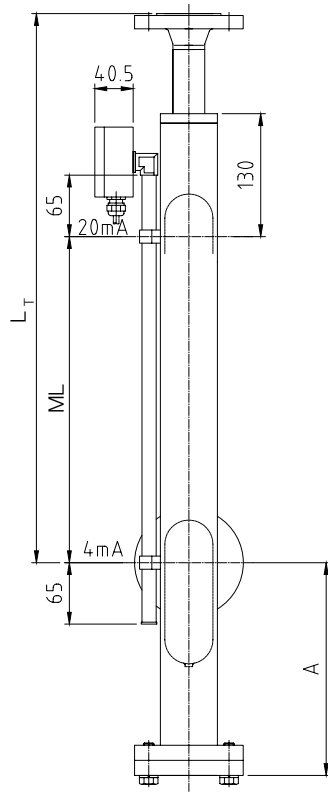

NBK... with Transmitter - Model H/F - Option ST

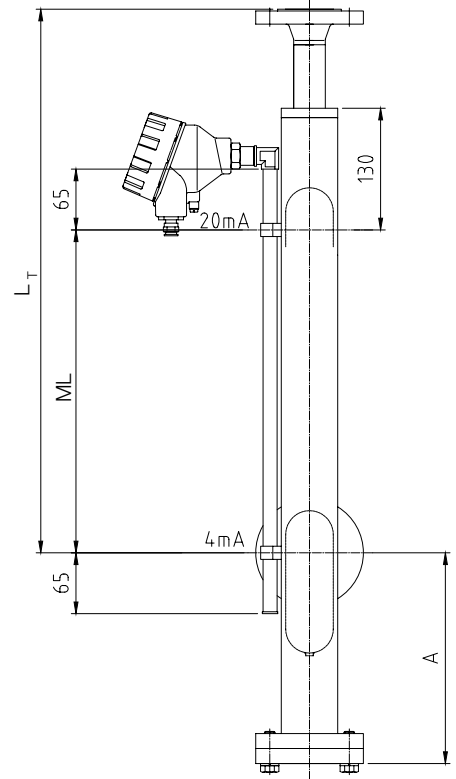

NBK... with Transmitter - Options MU and ST

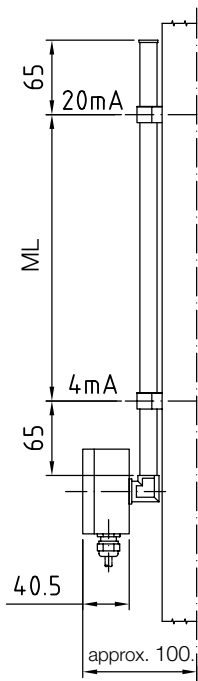

NBK... with Transmitter - Options MS and ST

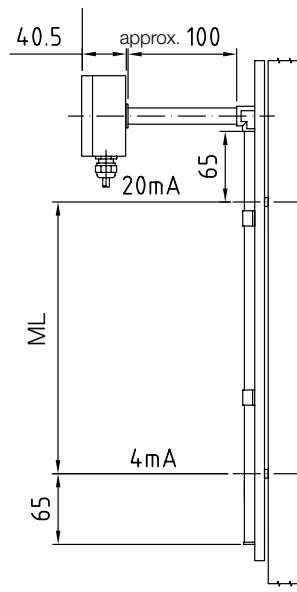

NBK... with Transmitter - Options MK and ST

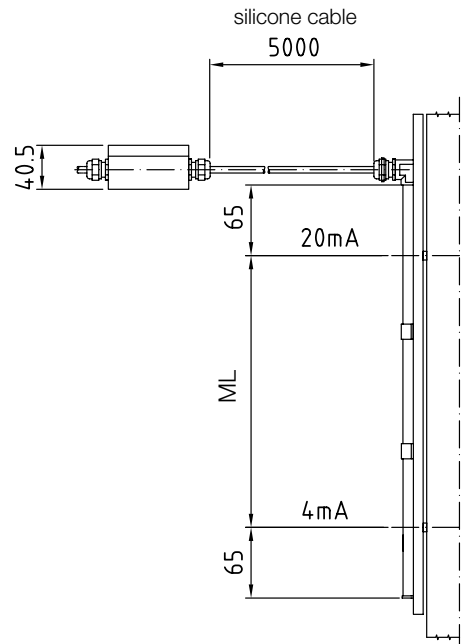

NBK... with Transmitter
 - Display Options AE/HE or AC/HC and Option ST

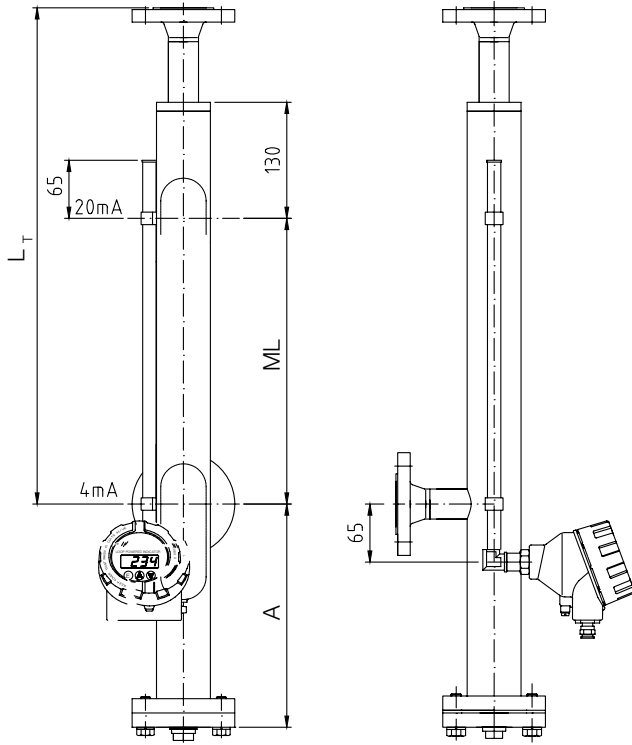

Process Connection - Option TT

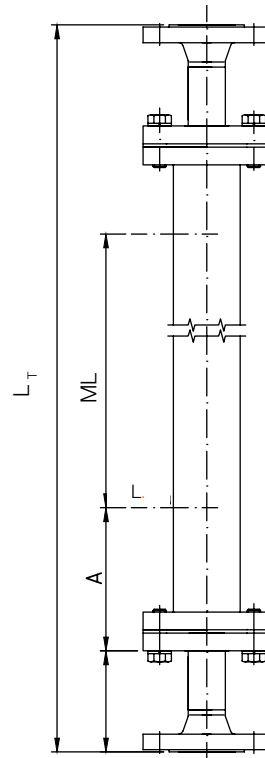

NBK... with Transmitter
 - Model M - Option TT

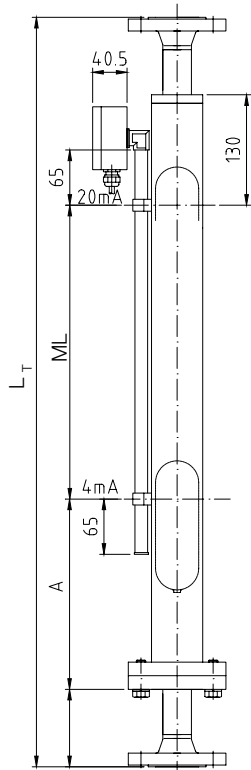

NBK... with Transmitter
 - Model H/F - Option TT

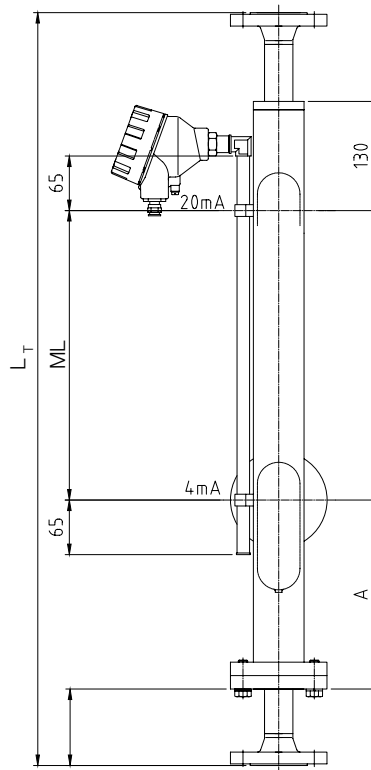

NBK... with Transmitter
 - Options MU and TT

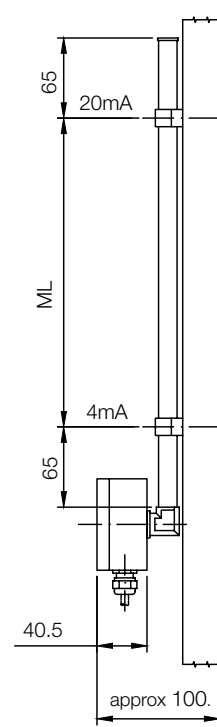

NBK-... with Transmitter
- Options MS and TT

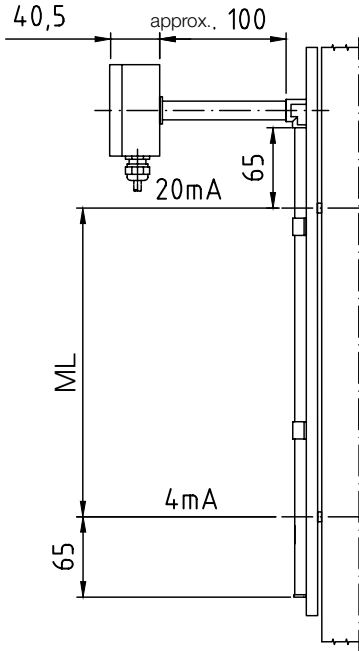

NBK-... with Transmitter
- Options MK and TT

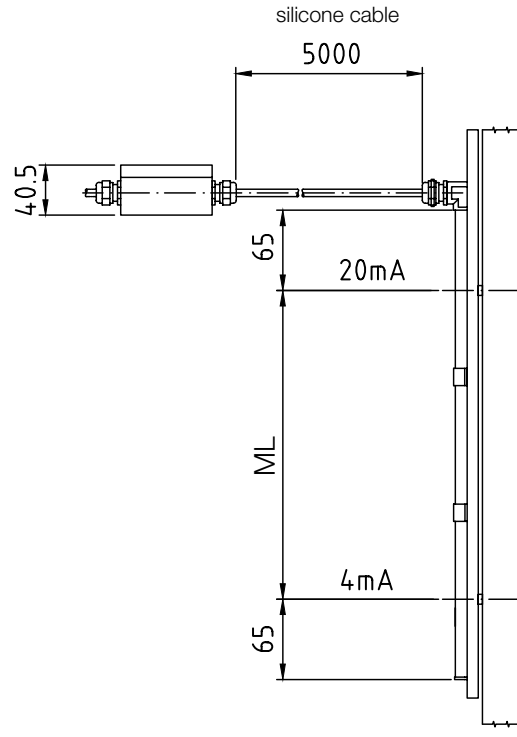

NBK-... with Transmitter - Display Options
AE/HE or AC/HC and Option TT

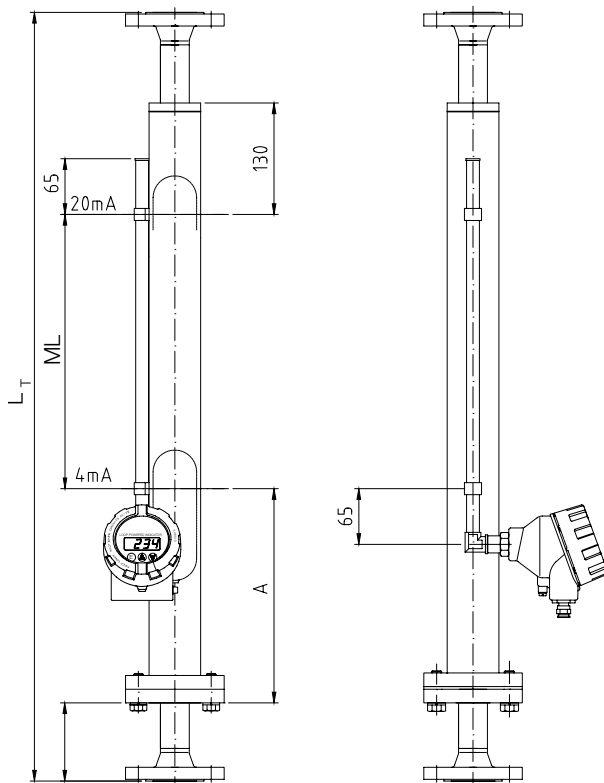

NBK-... with Indication Unit ADI-1 - Option C

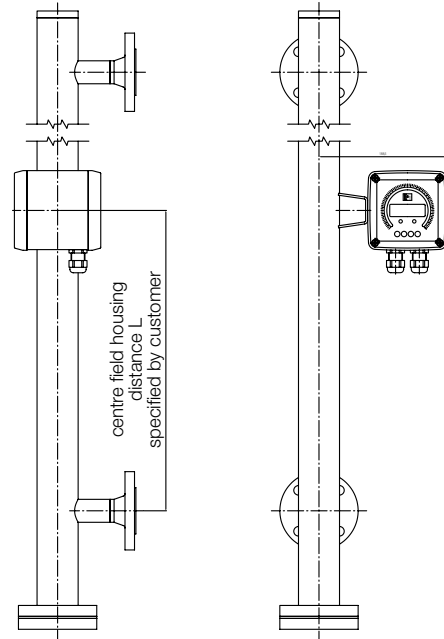

NBK-R

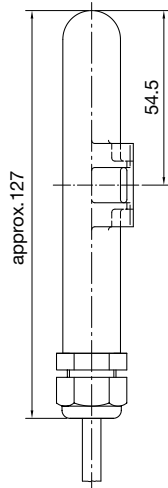

NBK-RV/RN

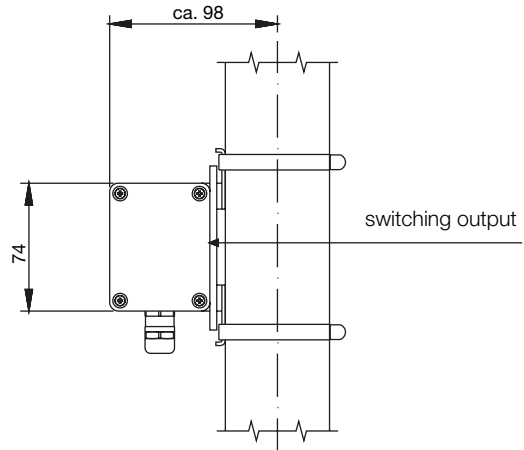

NBK-RT200

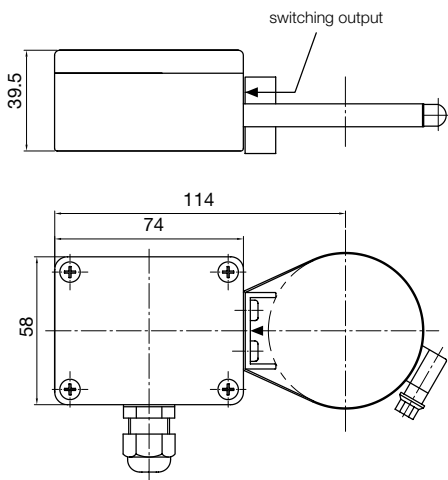

NBK-RT400

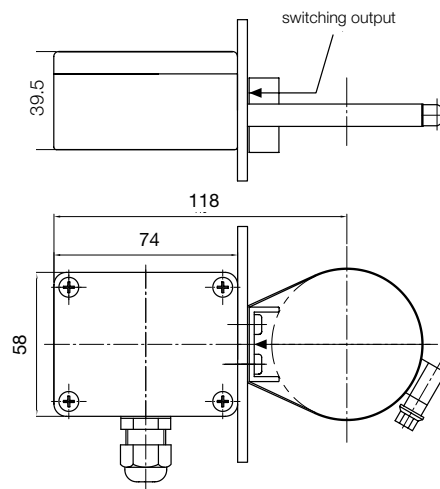

Order from: **C A Briggs Company**

622 Mary Street; Suite 101; Warminster, PA 18974

Phone: 267-673-8117 - Fax: 267-673-8118

Sales@cabriggs.com - www.cabriggs.com