

## Thermal Air Flow Switch



measuring  
•  
monitoring  
•  
analyzing

KAL-L



- Negligible Pressure Loss
- No Moving Parts
- Adjustable Response Time
- Compensated for Temperature
- Easy to Install



Order from: **C A Briggs Company**  
622 Mary Street; Suite 101; Warminster, PA 18974  
Phone: 267-673-8117 - Fax: 267-673-8118  
[Sales@cabriggs.com](mailto:Sales@cabriggs.com) - [www.cabriggs.com](http://www.cabriggs.com)



**Description**

The KOBOLD KAL-L flow switch allows rapid detection of flow rate changes in non-hazardous gases. Fast reaction times are guaranteed by the electronic design. Through use of two RTD's, one to sense flow and the other to detect ambient temperature, the switch can compensate for thermal changes in its surroundings. This "smart" behavior minimizes erroneous switching due to changes caused by things such as the weather. Almost any conceivable pipe size can be accommodated by the insertion style design. Knowledge of the flow velocity in your system is all that is needed to make the KAL-L work. Typical application areas include: air conditioning systems, ventilation systems, and other non-hazardous gas flow monitoring systems.



**Specifications**

- Power Supply:** 24 VAC/VDC - 15%, +10%
- Max. Power:** 4 VA
- Ambient Temperature:** 14...140 °F
- Media Temperature:** -10...250 °F
- Max. Pressure:** 120 PSIG
- Max. Warm-up Time:** 30 seconds
- Switching Range:** 3.3...66 ft/sec at 20 °C, 14.5 PSIG  
(Restricted Span for other Conditions)
- Switching Accuracy:** ± 10% of Reading
- Repeatability:** ± 1% of Reading
- Temperature Gradient:** 30 °K (°C)/min, @ 8m/s, 90 °C
- Response Time:** 1...60 s, Adjustable
- Flow Rate Indication:** 8-Digit LED Bargraph
- Switch Point Adjustment:** via Potentiometer
- Output Indicator:** 2-Color LED
- Switch Output:** Relay, SPDT
- Switch Capacity:** Max. 250 VAC / 1000 VA / 4A  
(Option M12: Max. 24 VAC/VDC, 3A)
- Protection:** IP 65
- Housing Material:** Polyamide
- Sensor Material:** Ni-plated Brass

**Electrical Connection**

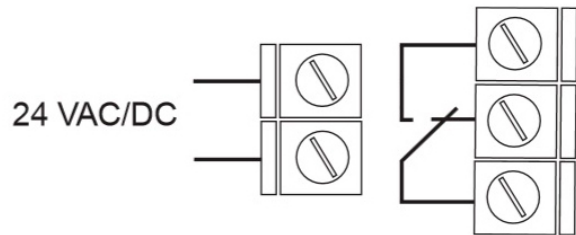

**Dimensions (mm)**

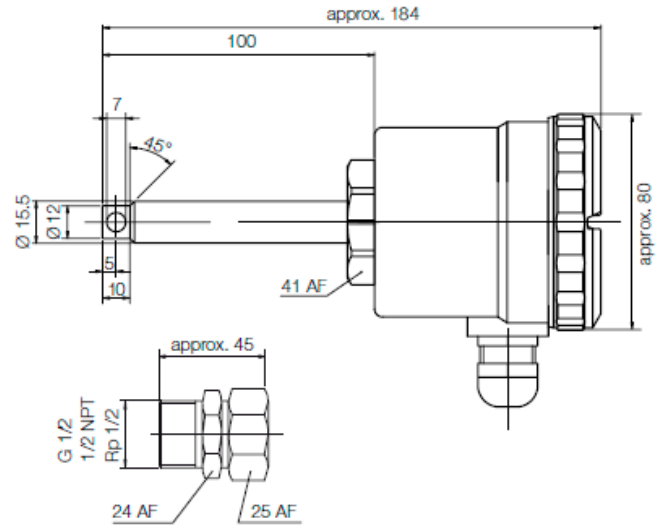

**Order Details** (Example: **KAL-8115 M12**)

Fitting	Order Number	Options
1/2" NPT	<b>KAL-8115</b>	<b>Suffix "C"</b> 1/2" Conduit Hub
2-Bolt Flange	<b>KAL-8115FL</b>	<b>Suffix "M12"</b> Quick Disconnect w/6" Cable